

## **Appendix A**

### **Permit Applications, Notice of Availability, and Notice of Intent**





## **Appendix A1**

**Permit Application, March 9, 2010**



# JOINT APPLICATION AND NOTIFICATION

U.S. ARMY CORPS OF ENGINEERS

MISSISSIPPI DEPARTMENT OF MARINE RESOURCES

MISSISSIPPI DEPARTMENT OF ENVIRONMENTAL QUALITY/OFFICE OF POLLUTION CONTROL

This form is to be used for proposed activities in waters of the United States in Mississippi and for the erection of structures on suitable sites for water dependent industry. Note that some items, as indicated, apply only to projects located in the coastal area of Hancock, Harrison and Jackson Counties.

**1. Date**

\_\_\_\_\_ month day year

**2. Applicant name, mailing address, phone number and email address:**

**Agent name, mailing address, phone number and email address:**

**3. Official use only**

COE \_\_\_\_\_

DMR \_\_\_\_\_

DEQ \_\_\_\_\_

A95 \_\_\_\_\_

DATE RECEIVED \_\_\_\_\_

**4. Project location**

Street Address \_\_\_\_\_ City/Community \_\_\_\_\_

Name of Waterway \_\_\_\_\_ Latitude \_\_\_\_\_ Longitude (if known) \_\_\_\_\_

Geographic location: Section \_\_\_\_\_ Township \_\_\_\_\_ Range \_\_\_\_\_ County \_\_\_\_\_

**5. Project description**

New work \_\_\_ Maintenance work \_\_\_

**Dredging**

\_\_\_ Channel length \_\_\_\_\_ width \_\_\_\_\_ existing depth \_\_\_\_\_ proposed depth \_\_\_\_\_

\_\_\_ Canal length \_\_\_\_\_ width \_\_\_\_\_ existing depth \_\_\_\_\_ proposed depth \_\_\_\_\_

\_\_\_ Boat Slip length \_\_\_\_\_ width \_\_\_\_\_ existing depth \_\_\_\_\_ proposed depth \_\_\_\_\_

\_\_\_ Marina length \_\_\_\_\_ width \_\_\_\_\_ existing depth \_\_\_\_\_ proposed depth \_\_\_\_\_

\_\_\_ Other-Mooring Basin length \_\_\_\_\_ width \_\_\_\_\_ existing depth \_\_\_\_\_ proposed depth \_\_\_\_\_

Cubic yards of material to be removed \_\_\_\_\_ Type of material \_\_\_\_\_

Location of spoil disposal area \_\_\_\_\_

Dimensions of spoil area \_\_\_\_\_ Method of excavation \_\_\_\_\_

How will excavated material be contained? \_\_\_\_\_

**Construction of structures**

\_\_\_ Bulkhead Total length \_\_\_\_\_ Height above water \_\_\_\_\_

\_\_\_ Pier length \_\_\_\_\_ width \_\_\_\_\_ height \_\_\_\_\_

\_\_\_ Boat Ramp length \_\_\_\_\_ width \_\_\_\_\_ slope \_\_\_\_\_

\_\_\_ Boat House length \_\_\_\_\_ width \_\_\_\_\_ height \_\_\_\_\_

\_\_\_ Structures on designed sites for water dependent industry (Coastal area only). Explain in item 11 or include as attachment.

\_\_\_ Other (explain) \_\_\_\_\_

**Filling**

Dimensions of fill area \_\_\_\_\_

Cubic yards of fill \_\_\_\_\_ Type of fill \_\_\_\_\_

**Other regulated activities (i.e. Seismic exploration, burning or clearing of marsh) Explain.**

\_\_\_\_\_  
\_\_\_\_\_  
\_\_\_\_\_  
\_\_\_\_\_

---

**6. Additional information relating to the proposed activity**

Does project area contain any marsh vegetation? Yes \_\_\_\_\_ No \_\_\_\_\_

(If yes, explain) \_\_\_\_\_

Is any portion of the activity for which authorization is sought now complete? Yes \_\_\_\_\_ No \_\_\_\_\_

(If yes, explain) \_\_\_\_\_

Month and year activity took place \_\_\_\_\_

If project is for maintenance work on existing structures or existing channels, describe legal authorization for the existing work. Provide permit number, dates or other form(s) of authorization. \_\_\_\_\_

Has any agency denied approval for the activity described herein or for any activity that is directly related to the activity described herein?

Yes \_\_\_\_\_ No \_\_\_\_\_ (If yes, explain) \_\_\_\_\_

---

**7. Project schedule**

Proposed start date \_\_\_\_\_ Proposed completion date \_\_\_\_\_

Expected completion date (or development timetable) for any projects dependent on the activity described herein. \_\_\_\_\_

---

**8. Estimated cost of the project** \_\_\_\_\_

---

**9. Describe the purpose of this project. Describe the relationship between this project and any secondary or future development the project is designed to support.** \_\_\_\_\_

\_\_\_\_\_

\_\_\_\_\_

Intended use: Private \_\_\_\_\_ Commercial \_\_\_\_\_ Public \_\_\_\_\_ Other (Explain) \_\_\_\_\_

---

**10. Describe the public benefits of the proposed activity and of the projects dependent on the proposed activity. Also describe the extent of public use of the proposed project.**

---

**11. Narrative Project Description:**

---

12. Provide the names and addresses of the adjacent property owners. Also identify the property owners on the plan view of the drawing described in Attachment "A". (Attach additional sheets if necessary.)

1.

2.

---

13. List all approvals or certifications received or applied for from Federal, State and Local agencies for any structures, construction, discharges, deposits or other activities described in this application. Note that the signature in Item 14 certifies that application has been made to or that permits are not required from the following agencies. If permits are not required, place N/A in the space for Type Approval.

<u>Agency</u>	<u>Type Approval</u>	<u>Application Date</u>	<u>Approval Date</u>
Dept. of Environmental Quality			
Dept. of Marine Resources			
Army Corps of Engineers			
City/County _____			
Other _____			

---

**14. Certification and signatures**

Application is hereby made for authorization to conduct the activities described herein. I agree to provide any additional information/data that may be necessary to provide reasonable assurance or evidence to show that the proposed project will comply with the applicable state water quality standards or other environmental protection standards both during construction and after the project is completed. I also agree to provide entry to the project site for inspectors from the environmental protection agencies for the purpose of making preliminary analyses of the site and monitoring permitted works. I certify that I am familiar with and responsible for the information contained in this application, and that to the best of my knowledge and belief, such information is true, complete and accurate. I further certify that I am the owner of the property where the proposed project is located or that I have a legal interest in the property and that I have full legal authority to seek this permit.

U.S.C. Section 1001 provides that: Whoever, in any manner within the jurisdiction of any department or agency of the United States knowingly and willingly falsifies, conceals, or covers up by any trick, scheme or device a material fact or makes any false, fictitious or fraudulent statements or representations or makes or uses any false writing or document knowing same to contain any false, fictitious or fraudulent statement or entry, shall be fined not more than \$10,000 or imprisoned not more than five years, or both.

**Mississippi Coastal Program (Coastal area only)**

I certify that the proposed project for which authorization is sought complies with the approved Mississippi Coastal Program and will be conducted in a manner consistent with the program.

---

Signature of Applicant or Agent

---

Date

---

**15. Fees**

Payable to MS Dept. of Marine Resources  
\$50.00 Single-family residential application fee  
\$500.00 Commercial application fee  
Public notice fee may be required

Please include appropriate fees for all projects proposed in coastal areas of Hancock, Harrison and Jackson Counties.

---

**16. If project is in Hancock, Harrison or Jackson Counties, send one completed copy of this application form and appropriate fees listed in Item 15 to:**

Department of Marine Resources  
Bureau of Wetlands Permitting  
1141 Bayview Avenue  
Biloxi, MS 39530  
(228) 374-5000

**If project IS NOT in Hancock, Harrison or Jackson Counties, send one completed copy of this application form to each agency listed below:**

District Engineer  
Mobile District  
Attn: CESAM-RD  
P.O. Box 2288  
Mobile, AL 36628-0001

District Engineer  
Vicksburg District  
Regulatory Branch  
Attn: CEMVK-OD-F  
4155 Clay Street  
Vicksburg, MS 39183-3435

Director  
Mississippi Dept. of Environmental Quality  
Office of Pollution Control  
P.O. Box 10385  
Jackson, MS 39289

---

**17. In addition to the completed application form, the following attachments are required:*****Attachment "A" Drawings***

Provide a vicinity map showing the location of the proposed site along with a written description of how to reach the site from major highways or landmarks. Provide accurate drawings of the project site with proposed activities shown in detail. All drawings must be to scale or with dimensions noted on drawings and must show a plan view and cross section or elevation. Use 8 1/2 x 11" white paper or drawing sheet attached.

***Attachment "B" Authorized Agent***

If applicant desires to have an agent or consultant act in his behalf for permit coordination, a signed authorization designating said agent must be provided with the application forms. The authorized agent named may sign the application forms and the consistency statement.

***Attachment "C" Environmental Assessment (Coastal Area Only)***

Provide an appropriate report or statement assessing environmental impacts of the proposed activity and the final project dependent on it. The project's effects on the wetlands and the effects on the life dependent on them should be addressed. Also provide a complete description of any measures to be taken to reduce detrimental offsite effects to the coastal wetlands during and after the proposed activity. Alternative analysis, minimization and mitigation information may be required to complete project evaluation.

***Attachment "D" Variance or Revisions to Mississippi Coastal Program (Coastal area only)***

If the applicant is requesting a variance to the guidelines in Section 2, Part III or a revision to the Coastal Wetlands Use Plan in Section 2, Part IV of the Rules, Regulations, Guidelines and Procedures of the Mississippi Coastal Program, a request and justification must be provided.

## ATTACHMENT - ADDITIONAL INFORMATION

### 5. Additional information relating to the dredging

Channels	Length	Width	Existing Depth	Proposed Depth
Turning Basin	1,300'	0' to 390'	-7'	-36'
Berthing Area	8,010'	1,510' to 1,890'	-7' to -36'	-36'
North Harbor Cut	2,850'	80'	-32' to +10'	-8'

### 6. Additional information relating to the proposed activity

The proposed project will incorporate the existing Mississippi State Port Authority (MSPA, the Port) facilities into the proposed project. It will also include the 84-acre fill area that was originally authorized under Department of the Army Permit MS96-02828-U. Sixty (60) acres of the 84-acre fill area are currently under construction and should be completed November 2010. Filling of the remaining 24 acres will start after the permit conditions and other environmental requirements have been satisfied. The expected start date for filling the remaining 24 acres is November 2010. The proposed project would require modification of the existing federally authorized Gulfport Harbor Navigation project, specifically the Turning Basin.

Sediment transport, current and water quality studies will be conducted during the permitting process to evaluate impacts of the proposed project. The need for additional water quality and fish passage channels will be considered during design of the project.

The need for biological, hydrologic and water quality monitoring will be determined during the design and permitting process.

Potential impacts of invasive species and encrusting organisms will be evaluated during the permitting and environmental evaluation process.

Potential impacts to Department of Marine Resources' low-profile reefs and potential effects to recreational fishing will be evaluated during the permitting process and appropriate mitigation considered.

The height of the bridge over the proposed North Harbor Cut will be determined as project design advances during the permitting process.

The MSPA understands the proposed project will require variances from the Mississippi Coastal Program and MSPA will address these issues during the permitting process once a better understanding of the potential impacts is understood.



#### Alternatives and on-site Avoidance:

As part of the National Environmental Policy Act (NEPA) process MSPA will conduct an alternative analysis to evaluate alternatives that could minimize the potential impacts to the natural environment while meeting the needs of MSPA to restore and revitalize the port. MSPA will conduct an alternative analysis that will include a broad range of alternatives that would be narrowed down to the top two or three feasible alternatives that would be evaluated in the NEPA document, in addition to the No Action alternative. As part of the alternatives analysis, MSPA will study the potential to use existing port uplands as part of an alternative to evaluate alternatives that would result in fewer acres of filled water bottoms.

#### Section 106:

Cultural resources in the project area were evaluated during preparation of an Environmental Impact Statement for widening the Gulfport Harbor Federal Navigation Channel (USACE 2008 and 2009). The following sources were consulted to locate records of previously identified historic and archaeological resources within the project area: USACE, National Park Service (NPS), National Register of Historic Places (NRHP), Mississippi State Historic Preservation Officer (SHPO), and the Automated Wreck and Obstruction Information System (AWOIS) database. In addition, the U.S. Coast Guard conducted an underwater remote sensing survey of Mississippi Sound within four miles of the shoreline in preparation for debris removal after Hurricane Katrina (Boudreaux and Pearson 2008). There are no known shipwrecks or archaeological sites in the area of direct project impact based on the research completed to date. The NRHP was consulted to determine if any NRHP properties are located on or near the proposed project. There are no NRHP properties on the project site. Two buildings and a historic district are located near the project site in downtown Gulfport. The Hewes Building is located at 2505 14<sup>th</sup> Street and the U.S. Post Office and Customhouse is located at 2421 13<sup>th</sup> Street. The Harbor Square Historic District is roughly bounded by the CSX railroad, 23<sup>rd</sup> Avenue, 13<sup>th</sup> Street, and 27<sup>th</sup> Avenue. Section 106 consultation will be initiated with SHPO and federally recognized Native American tribes to determine if there are any properties currently listed or potentially eligible for listing on the NRHP that would be impacted by the project.

#### Endangered and Threatened Species:

To determine whether suitable habitat for protected plant and animal species is present on the project site, lists of federal threatened and endangered species and state-listed endangered species compiled by the U.S. Fish and Wildlife Services (FWS) website (FWS 2008) and the Mississippi Museum of Natural Science on-line resources (MMNS 2003) were consulted. Additional information regarding habitat requirements and species range was acquired from the NatureServe on-line database (NatureServe 2009). There are a number of endangered and

threatened species which occur within the Gulfport area and the Mississippi Sound is listed as critical habitat for the Gulf sturgeon. The project will not affect most of the listed species, but potential impacts to listed species and critical habitat will be evaluated and coordinated with the FWS and National Marine Fisheries Service.

**9. Describe the purpose of this project. Describe the relationship between this project and any secondary or future development the project is designed to support.**

The purpose of the proposed project is to restore the Port of Gulfport from severe damage sustained from Hurricane Katrina, and to protect it from future damage while restoring the MSPA into a world class maritime facility. The enhancements to the Port will ensure that it will be a large sustainable economic engine for the State of Mississippi. The proposed project will facilitate the revitalization of the Port and related public infrastructure and facilities, minimize future storm damage by elevating the Port to +25', provide for the long-term recovery of the operating capacity of the Port, and make jobs available to low-to-moderate-income workers.

There are no specific secondary or future development projects that the proposed project is designed to support. However, development of a world class maritime facility would be expected to generate secondary development such as warehouses and value added distribution centers.

Deepening and widening of the Gulfport Harbor Federal Navigation Channel is not required to support the proposed project but would likely be required before any future long-term development of the Port.

The MDOT I-10 Connector Road between I-10 and the Port is planned to support the existing facilities on the Port. Alternative routes are being considered for the extreme southern end of the Connector Road to establish a better tie in to the Port. These alternative connections for the I-10 Connector Road to the Port will be addressed during the permitting and environmental evaluation process.

The MSPA will evaluate potential improvements to the rail lines between the Port and I-10. These improvements will be addressed during the MSPA PGRP permitting and environmental evaluation process.

**10. Describe the public benefits of the proposed activity and of the projects dependent on the proposed activity. Also describe the extent of public use of the proposed project.**

The proposed project will provide local, state and national economic benefits as well as providing jobs for low-to-moderate-income individuals.

The proposed North Harbor Cut will provide the public with small craft access up and down the near shore coast of the Mississippi Sound without having to navigate south and around the Port, crossing the navigation channel. Access to the Yacht Basin on the northeast side of the proposed project will be maintained.

## **11. Narrative Project Description:**

### **11.1 Background**

On August 29, 2005, Hurricane Katrina made landfall on the Mississippi Gulf Coast, resulting in one of the most significant natural disasters in the U.S. history. The Port's electrical power supply, roads, water, sewer, rail, small craft harbor fender systems, navigation aids, and lighting and security systems were all destroyed or damaged beyond repair by the storm.

As a result of Hurricane Katrina, approximately \$5 billion in Federal aid was appropriated to the State of Mississippi to assist in recovery and rebuilding efforts. The MSPA was designated as a key element in these efforts and funds have been obligated to establish a sustainable port facility capable of repositioning itself in the maritime marketplace.

The restoration of the Port is crucial to the economy and long-term recovery of the State of Mississippi and the Gulf Coast region in particular. Furthermore, manufacturing companies located throughout the State depend on the products imported through this port.

The MSPA is responsible for the daily operations and infrastructure of the Port. As an Enterprise Agency of the State of Mississippi, the MSPA receives no annual general fund appropriation from the state, but instead operates as a private business. Its income is derived from port usage, service fees, lease agreements, and other tenant related fees.

Loss in operating capacity as a result of Hurricane Katrina has directly impacted the number of job opportunities at the Port. In 2005, before Hurricane Katrina, there were 3,200 direct, induced, and indirect maritime jobs associated with the Port. Currently, there are 2,000.

The Port of Gulfport Restoration Program (PGRP) provides funding to the MSPA to facilitate the restoration of public infrastructure and publicly-owned facilities destroyed by Hurricane Katrina, to minimize future damage to the Port, and to provide for the long-term recovery and revitalization of the operating capacity of the Port.

The total amount obligated by the U.S. Department of Housing and Urban Development (HUD) for the PGRP, including administrative costs, is an amount not to exceed \$570 million. This grant money will be made available from the Mississippi Development Authority (MDA) to the MSPA, the state agency responsible for the infrastructure, management, and operation of the Port, through a sub-recipient agreement.

As the recipient of this funding, the MSPA and its tenants will restore port facilities. The improved port facilities will support the creation of new jobs for low-to-moderate-income workers. MSPA's tenants will be required to sign a contract/Memorandum of Agreement (MOA) with the MSPA to identify the number of jobs created or retained for low-to-moderate-income persons. These efforts will provide relief and long-term recovery to the disaster area and are consistent with the Community Block Grant (CDBG) Program's primary purpose.

## **11.2 Dredging**

The proposed project will require dredging for a portion of the new turning basin, for access to the new berths, and the North Harbor Cut (navigation/circulation/water quality/fish passage channel).

Dredging for the portion of the new Turning Basin located outside the authorized Federal project will require dredging approximately 160,000 CY. The dredged material that is structurally suitable will be used for fill on the project site. Any material that is not structurally suitable will be evaluated for potential beneficial use. Material that is not suitable for beneficial use will be disposed of in an approved ODMDS. Material that is suitable for beneficial use will be placed in the Littoral Zone Disposal Area southeast of Cat Island or in another approved area.

Dredging for access to the new berths will require dredging approximately 16,200,000 CY. Dredged material that is structurally suitable will be used for fill on the project site. Any material that is not structurally suitable will be evaluated for potential beneficial use. Material that is not suitable for beneficial use will be disposed of in an approved ODMDS. Material that is suitable for beneficial use will be placed in the Littoral Zone Disposal Area southeast of Cat Island or in another approved area.

Dredging for access to the North Harbor Cut will require excavation and dredging approximately 1,900,000 CY. Most of the material is structurally suitable and will be used for fill on the project site. Any material that is not structurally suitable will be evaluated for potential beneficial use. Material that is not suitable for beneficial use will be disposed of in an approved ODMDS. Material that is suitable for beneficial use will be placed in the Littoral Zone Disposal Area southeast of Cat Island or in another approved area.

The existing Commercial Small Craft Channel and Harbor located on the west side of the proposed project will be abandoned. Based on permitting challenges to rebuild the destroyed harbor facilities, the lack of public funds, the uncertainty for the economic justification for the harbor, and lack of a legal obligation to rebuild the commercial small craft harbor, the Port has decided to not rebuild the small craft harbor. In addition, if the proposed project is permitted,

the Commercial Small Craft Channel and Harbor may have to be demolished. If the channel and harbor are abandoned, Congressional authorization will be required.

### **11.3 Construction of Structures**

The proposed project will require construction of wharves/pier, bulkheads and breakwater structures for the restoration and revitalization of the Port. Approximately 12,660 linear feet of marginal wharf (pier structure) will be constructed around the proposed Turning Basin and along the eastern edge of the west fill area. The wharf/pier is proposed to be constructed of a steel sheet pile wall along the breasting line (front face of the wharf) and filled behind with soil with an asphalt paved surface. The wharf will be approximately 130 feet wide and constructed at elevation +9.5 feet North American Vertical Datum (NAVD 1988). Directly behind the 130 feet wide wharf, a retaining wall structure will be constructed to allow the backland areas to be constructed at approximately elevation +25 feet NAVD 88.

Approximately 7,590 linear feet of rip-rap breakwater will be constructed along the east side of the ship channel to provide wave protection for the proposed project. The breakwater will vary from 98 to 102 feet wide at its base with a top width of 10 feet and a top elevation of +10 feet NAVD 88. Hydrodynamic models and possibly ship models will be used to determine the need for and the final dimensions of the breakwater, if it is required.

### **11.4. Filling**

The proposed project will require filling approximately 681 acres of water bottoms for the restoration and revitalization of the Port. Approximately 38,400,000 CY of predominately sandy fill material will be required. The fill material will come from commercial borrow pits and/or through the use of dredged material from channel dredging projects, excess excavated material from road construction projects, and other approved sources.

Armor protection will be provided on the exposed faces of the proposed fill that are not protected by a bulkhead.

Breakwater construction will require placing approximately 224,000 cubic yards of rip-rap on approximately 17.4 acres of water bottoms.

### **11.5 Mitigation Plan**

A detailed mitigation plan will be developed during the permit and NEPA review process. The conceptual plan for development of the detailed mitigation plan includes using the Mississippi Coastal Improvements Program (MsCIP) and Mississippi Department of Marine Resources (DMR) Coastal Impact Assistance Program (CIAP) as resources. Coastal restoration projects evaluated under these programs, which were not chosen for implementation, will be

considered for inclusion in the detailed mitigation plan for the proposed project. Other options include the possibility of enhancing coastal marshes located in the Hancock County Marshes Coastal Preserve, part of the state’s coastal preserve program, subsidizing the creation of near shore reefs, deployment of derelict vessels within the fish havens, clutch plants for existing oyster reefs, management of coastal preserves, acquisitions of new properties to be included in the coastal preserve program, and testing dredged material for potential beneficial use. Other potential mitigation options recommended by the resource agencies and the public will also be considered for inclusion in the detailed plan. Finally, the MSPA’s Environmental Consultant may recommend additional potential mitigation sites. A draft Conceptual Mitigation Plan will be developed and coordinated with the resource agencies for review and comment. The level of mitigation will likely be based on best professional judgment since there is currently no accepted methodology for evaluating water column and water bottom impacts.

**12. Provide names and addresses of the adjacent property owners. Also identify the property owners on the plan view of the drawing described in Attachment “A”.**

- |   |   |
|---|---|
| 1. City of Gulfport<br>Post Office Box 1780<br>Gulfport, MS 39502   | 2. Gulfside Casino Partnership - Lessee<br>3300 W. Beach Blvd<br>Gulfport, MS 39501                 |
| 3. Barber Southern, LLC<br>116 Brighton Close<br>Nashville, TN 37205  | 4. Boat Fresh Seafood/Mike Sevel – Lessee<br>17061 Landon Road<br>Gulfport, MS 39503                |
| 5. Roberta V. Brady – Lessee<br>3908 28 <sup>th</sup> Street<br>Gulfport, MS 39501                                    | 6. Duratex North America, Inc. – Lessee<br>1208 Eastchester Drive, Suite 202<br>Highpoint, NC 27265 |
| 7. E N Bisso, LLC<br>3939 N Causeway Blvd, Suite 401<br>Metairie, LA 70002  | 8. Gulfport Harbor Fuel and Bait – Lessee<br>940 Pass Road<br>Gulfport, MS 39501                    |
| 9. Gulfport Purchasing, Inc. – Lessee<br>Post Office Box 55<br>Gulfport, MS 39502                                     | 10. Gulfport Yacht Racing Associates – Lessee<br>Post Office Box 34<br>Gulfport, MS 39502           |
| 11. Carl Lizana – Lessee<br>334 E. Beach Blvd<br>Gulfport, MS 35907   | 12. Marine Life, Inc.<br>Post Office Box 4078<br>Gulfport, MS 39502                                 |
| 13. Mississippi Coast Marine, Inc. – C/O George P. Hopkins, Inc.<br>520 34 <sup>th</sup> Street<br>Gulfport, MS 39507 | 14. MS Cellular South, Inc. – Lessee<br>1018 Highland Colony Parkway<br>Ridgeland, MS 39157         |
| 15. P and O Ports GPT, Inc.<br>Post Office Box 4241<br>Gulfport, MS 39502   | 16. Peter M. Skrmetta – Lessee<br>Post Office Box 1467<br>Gulfport, MS 39502                        |

- |   |   |
|---|---|
| 17. Standard Fruit and Steamship Co./Dole – Dole Fruit – Bob Finley<br>Post Office Box 1689<br>Gulfport, MS 39502 | 18. United Brands, Inc./Chiquita – Lessee<br>Post Office Box 1017<br>Gulfport, MS 39502                 |
| 19. US Coast Guard<br>Post Office Box 1056<br>Gulfport, MS 39502  | 20. Mississippi Secretary of State<br>Public Lands Attorney<br>Post office Box 97<br>Gulfport, MS 39502 |
| 21. Mississippi Power Company<br>30 <sup>th</sup> Avenue<br>Gulfport, MS 39502                                    |   |

**13. List of approvals or certifications received or applied for from Federal, State and Local agencies for any structures, construction, discharges, deposits or other activities in this application. Note that the signature in item 14 certifies that application has been made to or that permits are not required from the following agencies. If permits are not required, place N/A in the space for Type Approval.**

**Other:** The following approvals are not required at this time but will likely be required before or shortly after a permit is issued:

HUD – Approval for Release of Funds

NMFS – Incidental Take Permit for the Gulf Sturgeon

MS Secretary of State – Approval for use of State Lands/Water Bottoms

USACE – Section 404(b)(1) Evaluation





**Attachment "A" Drawings**



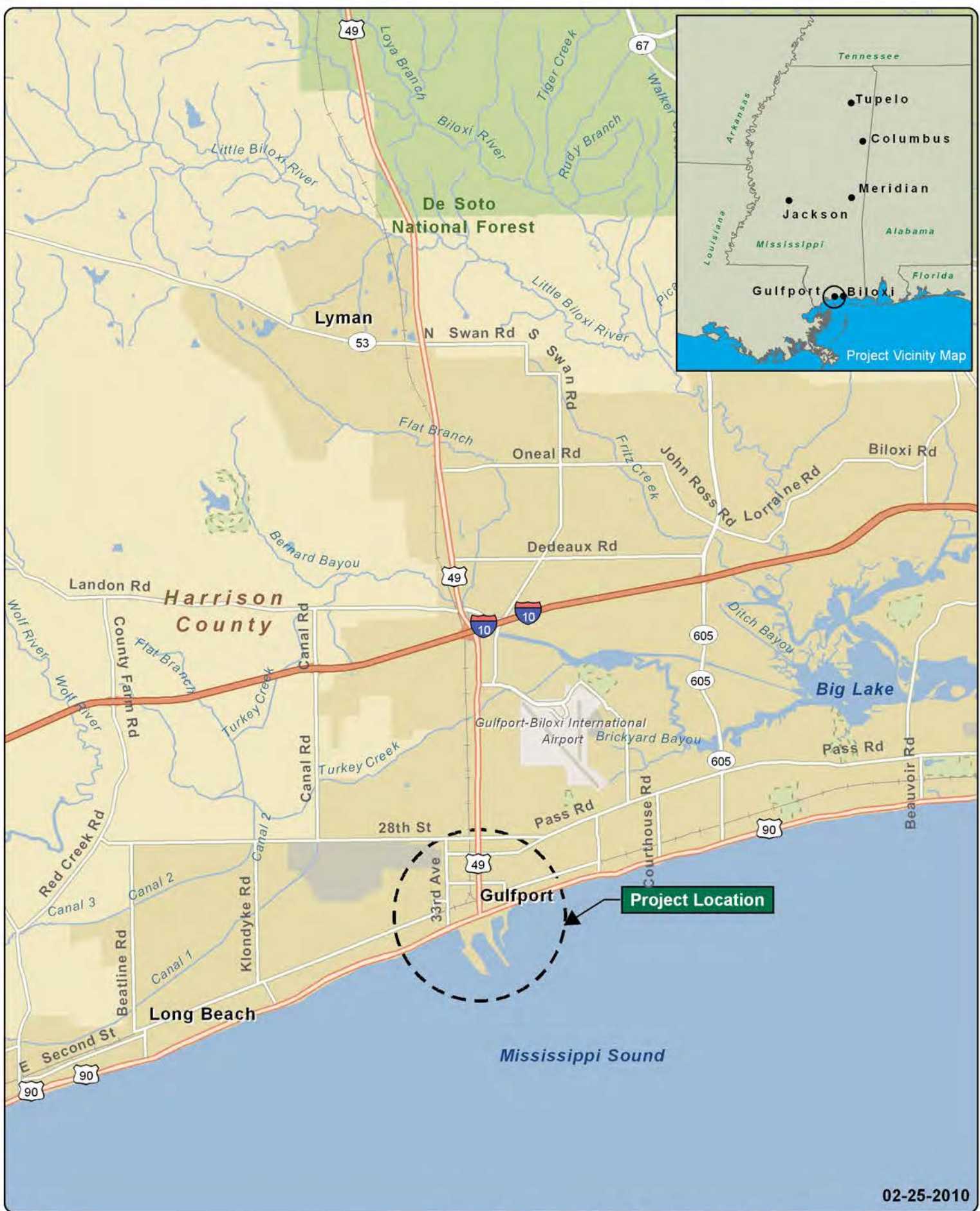





As Built Channel

24 Acres  
30 Acres  
30 Acres

**Legend**

-  84 - Acre Permitted Fill Area (MS96 - 02828 - U)
-  Permitted Dredging Areas (SAM - 2009 - 0433 - JBM)
-  Gulfport Harbor Federal Channel & Turning Basin
-  Yacht Club Channel

02-25-2010

**VOLKERT**

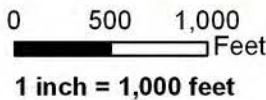

Note: This map is for presentation use only and not to be used for construction purposes.

**PORT OF GULFPORT RESTORATION PROGRAM**

**Figure 2 Existing Port**



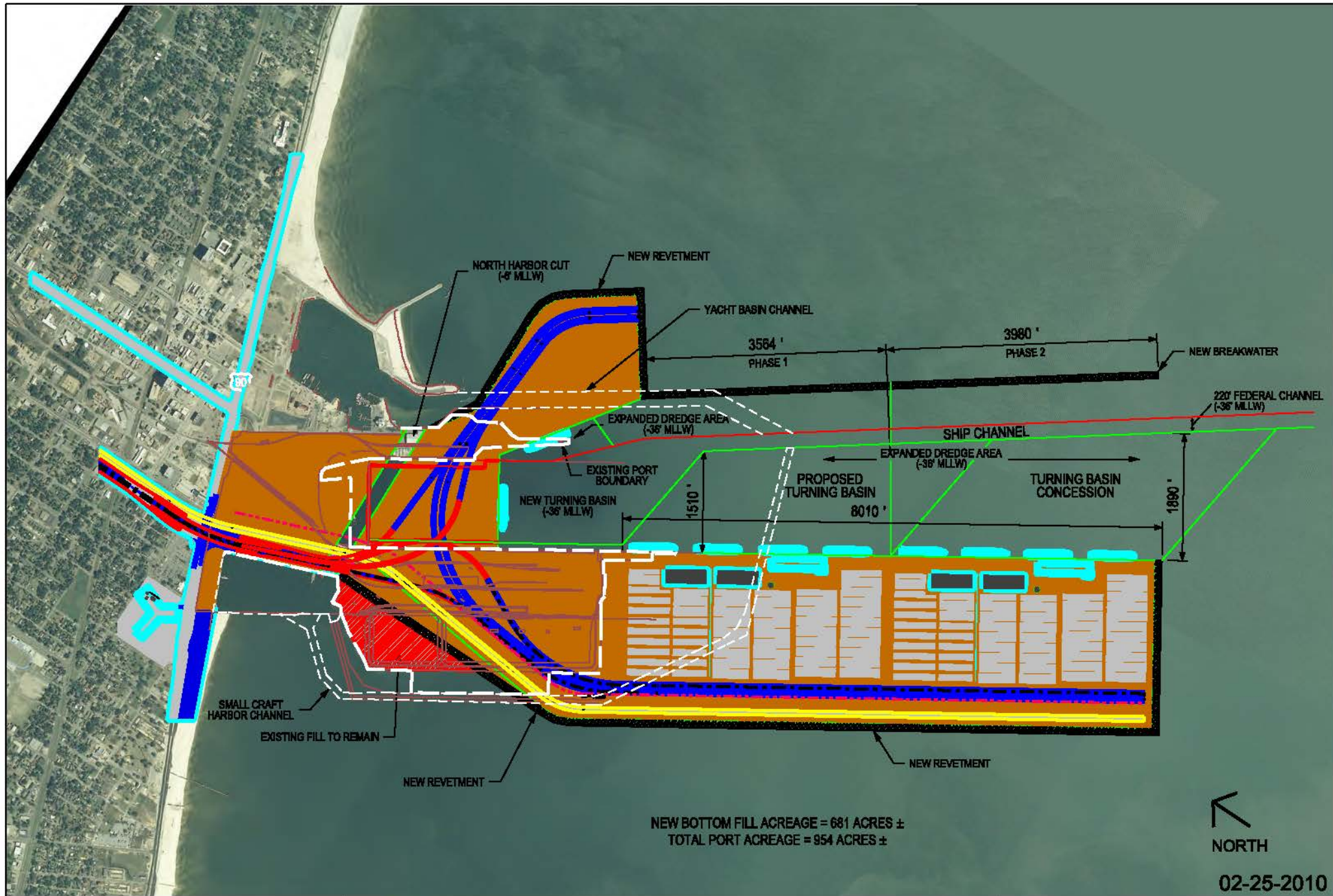

**VOLKERT**



**PORT OF GULFPORT  
RESTORATION  
PROGRAM**

NOTE:  
SCALE = 1" = 1800'

**FIGURE 3  
PROPOSED PLAN**

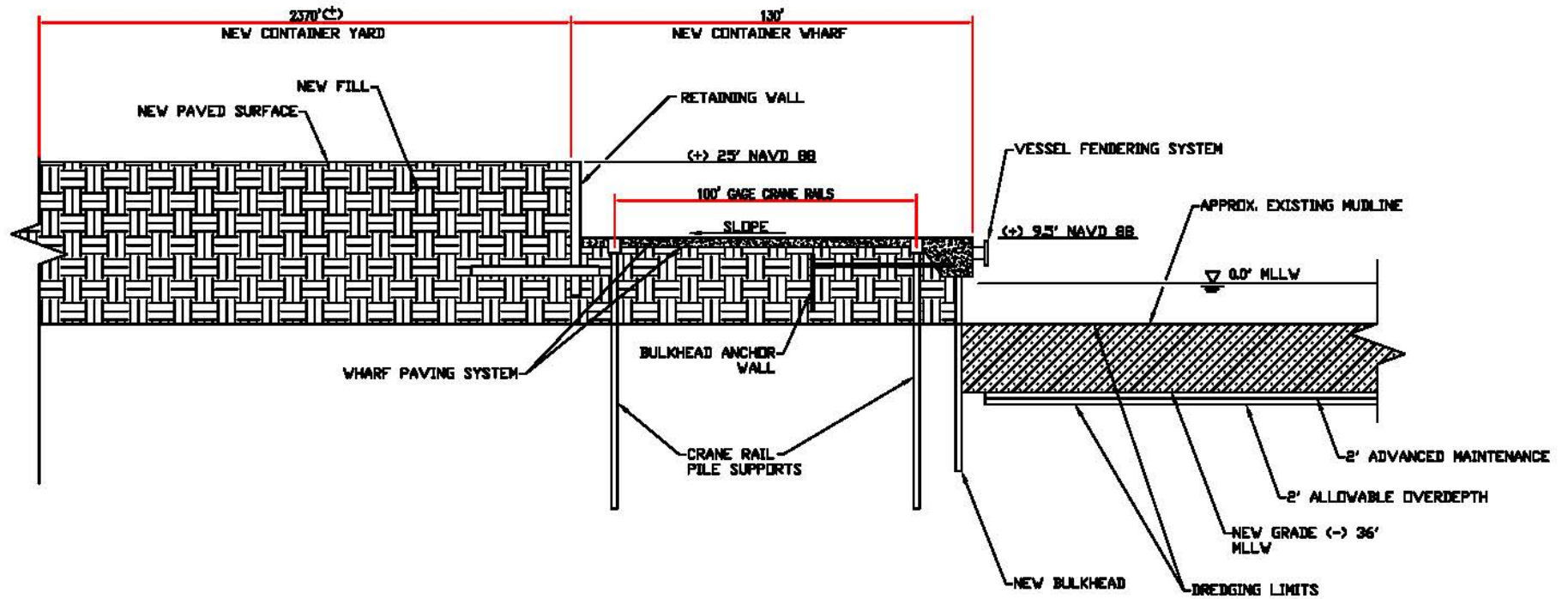

02-25-2010

**VOLKERT**

SCALE:  
1" = 50'



PORT OF GULFPORT  
RESTORATION  
PROGRAM

FIGURE 4  
TYPICAL WHARF AND  
FILL CROSS SECTION

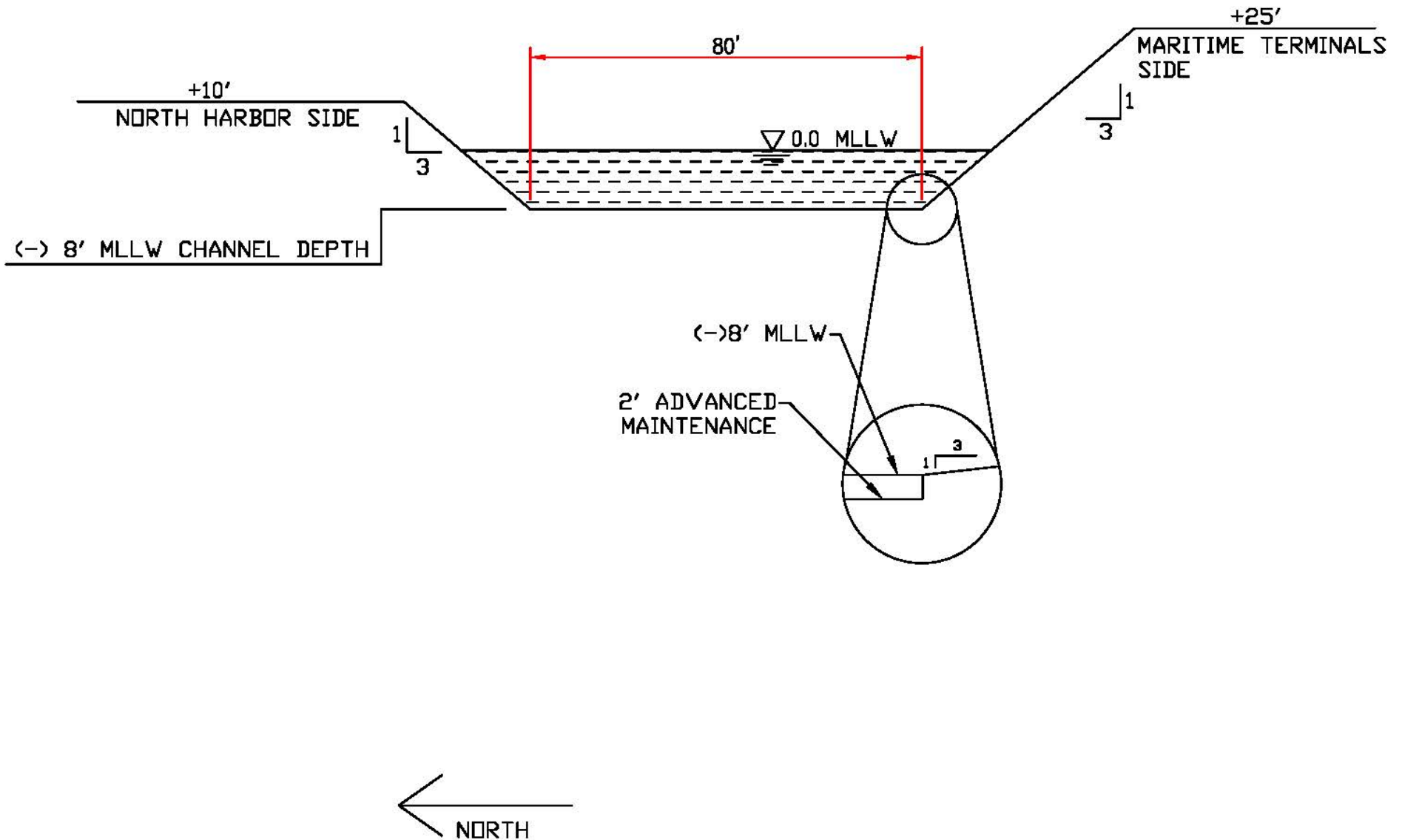

02-25-2010

**VOLKERT**

SCALE:  
1" = 30'



PORT OF GULFPORT  
RESTORATION  
PROGRAM

FIGURE 5  
NORTH HARBOR CUT  
TYPICAL CHANNEL  
CROSS SECTION



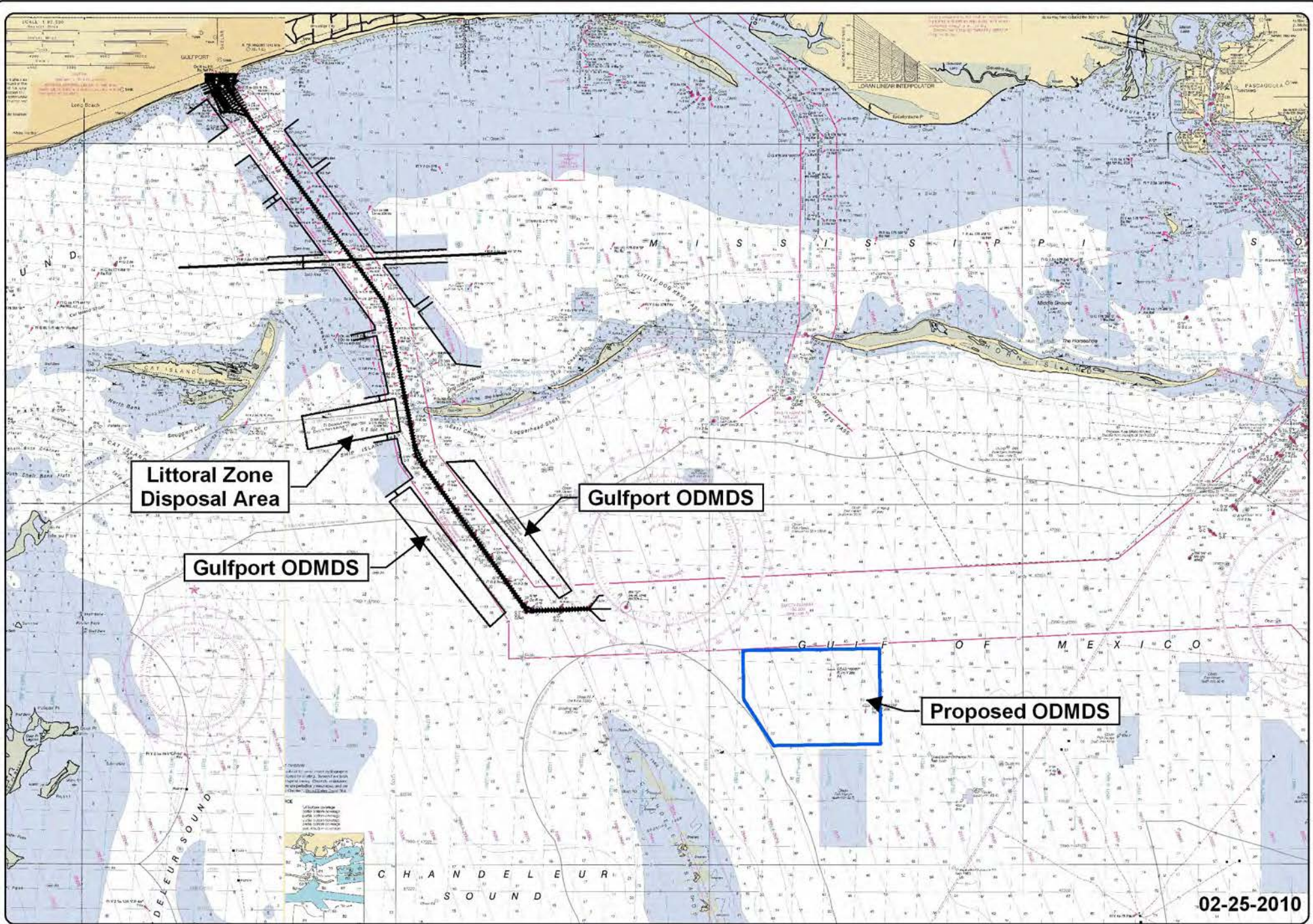

02-25-2010

Note: This map is for presentation use only and not to be used for construction purposes.

**VOLKERT**

0 2 4 Miles  
1 inch = 4 miles



**PORT OF GULFPORT RESTORATION PROGRAM**

**Figure 6  
Ocean Dredge Material Disposal Sites  
and Littoral Zone Disposal Area**



NOTE:

APPROXIMATELY 7,590 LF OF NEW  
BREAKWATER REQUIRED.

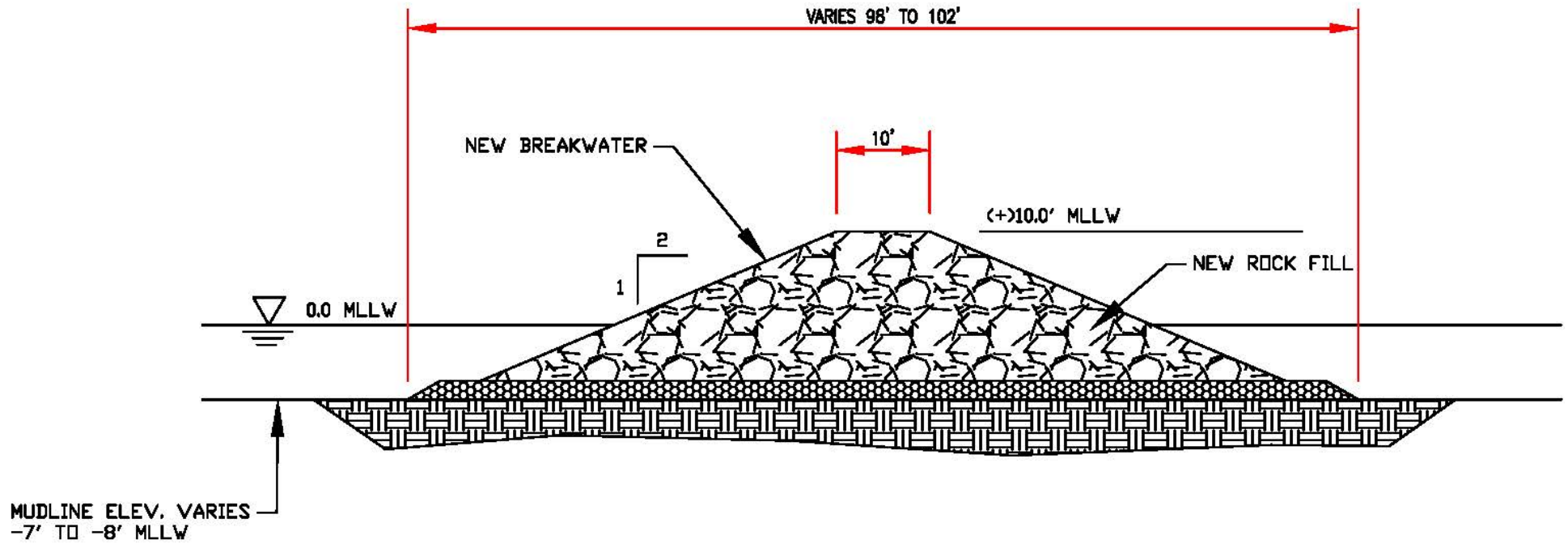

02-25-2010

**VOLKERT**

SCALE:  
1" = 20'



PORT OF GULFPORT  
RESTORATION  
PROGRAM

FIGURE 7  
TYPICAL BREAKWATER  
SECTION



Attachment "B" Authorized Agent





# MISSISSIPPI DEPARTMENT OF MARINE RESOURCES

## Agent Authorization

I authorize the person(s) and/or company listed below to act as my agent regarding the proposed project as described in the Joint Application and Notification at the location listed below:

\_\_\_\_\_  
(name of agent)

\_\_\_\_\_  
(location of project)

\_\_\_\_\_  
(address)

\_\_\_\_\_

\_\_\_\_\_  
(city, state, zip code)

\_\_\_\_\_

\_\_\_\_\_  
(agent phone number)

\_\_\_\_\_  
(print your name)

\_\_\_\_\_  
(your signature)

\_\_\_\_\_  
(date)

Do you want the permit mailed to the agent? \_\_\_\_ Yes \_\_\_\_ No



**Appendix A2**

**Public Notice, April 16, 2010**







REPLY TO  
ATTENTION OF:

DEPARTMENT OF THE ARMY  
U.S. ARMY ENGINEER DISTRICT, MOBILE DISTRICT  
P.O. BOX 2288  
MOBILE, ALABAMA 36628-0001

April 16, 2010

Coastal Branch  
Regulatory Division

**JOINT PUBLIC NOTICE SAM-2009-01768-DMY  
U.S. ARMY CORPS OF ENGINEERS**

**MISSISSIPPI DEPARTMENT OF ENVIRONMENTAL QUALITY  
OFFICE OF POLLUTION CONTROL**

**MISSISSIPPI DEPARTMENT OF MARINE RESOURCES**

**PROPOSED IMPACTS TO OPEN WATER AND WATERFRONT DEVELOPMENT  
ASSOCIATED WITH THE RESTORATION AND REVITALIZATION OF THE  
PORT OF GULFPORT, HARRISON COUNTY, MISSISSIPPI**

TO WHOM IT MAY CONCERN:

This District has received an application for a Department of the Army permit pursuant to Section 10 of the River and Harbors Act of 1899, Section 404 of the Clean Water Act and Section 103 of the Marine Protection, Research and Sanctuaries Act. Please communicate this information to interested parties.

**APPLICANT:** Mississippi State Port Authority  
Attention: Mr. Joe Conn  
Post Office Box 40  
Gulfport, Mississippi 39502

**AGENT:** Volkert, Inc.  
Attention: Mr. Henry Malec  
Post Office Box 7434  
Mobile, Alabama 36670

**WATERWAY:** Mississippi Sound, Port of Gulfport, Section 9, Township 8 South, Range 11 West, Harrison County, Mississippi (Latitude 30.3557 North, Longitude -89.0977 West).

**WORK:** The applicant, Mississippi State Port Authority (MSPA) proposes impacts to approximately 700 acres of open water bottom in Mississippi Sound associated with the Port of Gulfport Restoration and Revitalization Program. Construction would consist of the filling of open water bottom, dredging operations, construction of a new turning basin and other items. The purpose of the proposal is for the restoration and revitalization of the existing port facility associated with a Community Development Block Grant through the U.S. Department of Housing and Urban Development in the amount not to exceed \$570 million. This grant money would be made available from the Mississippi Development Authority (MDA) to the MSPA, the State agency responsible for the infrastructure, management and operation of the Port, through a sub-recipient agreement. As the recipient of this funding, MSPA and its tenants would restore the Port of Gulfport from severe damage sustained by Hurricane Katrina, with the applicant's long-

term intent to develop a world class maritime facility. Construction of the improved port facilities would support the creation of new jobs for low to moderate income workers. The proposed project would consider the existing MSPA port facilities in the proposed project. It would also include the 84-acre fill area that was originally authorized under Department of the Army permit MS96-02828-U. Sixty acres of the 84-acre fill area is currently under construction and should be completed by November 2010. The expected start date for filling the remaining authorized 24 acres is November 2010.

The proposed project would require construction of wharves/piers, bulkheads and breakwater structures for the restoration and revitalization of the Port. Approximately 12,660 linear feet of marginal wharf (pier structure) would be constructed around the proposed Turning Basin and along the eastern edge of the west fill area. The wharf/pier is proposed to be constructed of a steel sheet pile wall along the breasting line (front face of the wharf) and filled behind with soil with an asphalt paved surface. The wharf would be approximately 130 feet wide and constructed at elevation +9.5 feet North American Vertical Datum (NAVD 1988). Directly behind the 130-foot-wide wharf, a retaining wall structure would be constructed to allow the backland areas to be constructed at approximately elevation +25 feet NAVD 88.

Approximately 7,590 linear feet of riprap breakwater would be constructed along the east side of the ship channel to provide wave protection for the proposed project. The breakwater would vary from 98 to 102 feet wide at its base with a top width of 10 feet and a top elevation of +10 feet NAVD 88. Hydrodynamic models and possibly ship models would be used to determine the need for and the final dimensions of the breakwater, if required.

The proposed project would require the filling of approximately 700 acres of open water bottoms for the restoration and revitalization of the facility. Approximately 38,400,000 cubic yards (CY) of predominately sandy fill material would be required. The fill material would come from commercial borrow pits and/or through the use of dredged material from channel dredging projects, excess excavated material from road construction projects and other approved sources.

Armor protection would be provided on the exposed faces of the proposed fill that are not protected by a bulkhead. Breakwater construction would require placing approximately 224,000 CY of riprap on approximately 17.4 acres of open water bottoms.

According to the applicant, the project as proposed would require modification of the existing Federally authorized Gulfport Harbor Navigation project, specifically the Turning Basin. The proposed project would require dredging for a portion of the new turning basin, for access to the new berths and the North Harbor Cut (navigation/circulation/water quality/fish passage channel). Dredging for the portion of the new Turning Basin located outside the authorized Federal project would require dredging approximately 160,000 CY. The dredged material structurally suitable would be used for fill on the project site. Any material not structurally suitable would be evaluated for potential beneficial use. Material not suitable for beneficial use would be disposed of in an approved ocean dredged material disposal site (ODMDS). Material suitable for beneficial use would be placed in the Littoral Zone Disposal Area southeast of Cat Island or in another approved area.

Dredging for access to the new berths would require dredging approximately 16,200,000 CY. Dredged material structurally suitable would be used for fill on the project site. Any material not structurally suitable would be evaluated for potential beneficial use. Material not suitable for beneficial use would be disposed of in an approved ODMDS. Material suitable for beneficial use would be placed in the Littoral Zone Disposal Area southeast of Cat Island or in another approved area.

Dredging for access to the North Harbor Cut would require excavation and dredging approximately 1,900,000 CY. Most of the material is structurally suitable and would be used for fill on the project site. Any material not structurally suitable would be evaluated for potential beneficial use. Material not suitable for beneficial use would be disposed of in an approved ODMDS. Material suitable for beneficial use would be placed in the Littoral Zone Disposal Area southeast of Cat Island or in another approved area.

The existing Commercial Small Craft Channel and Harbor located on the west side of the proposed project would be abandoned. Based on permitting challenges to rebuild the destroyed harbor facilities, the lack of public funds and the uncertainty for the economic justification for the harbor, the Port has decided to not rebuild the small craft harbor. In addition, if the proposed project is authorized, the Commercial Small Craft Channel and Harbor may have to be demolished. If the channel and harbor are abandoned, Congressional authorization would be required.

At this time, the applicant has stated there are no specific secondary or future development projects the proposed project is designed to support. However, it was stated by the applicant development of this facility may generate secondary development such as warehouses and value added distribution centers. Deepening and widening of the Gulfport Harbor Federal Navigation Channel is not required to support the project as proposed at this time but would likely be required before any future long-term development of the proposed facility.

The Mississippi Department of Transportation I-10 Connector Road between I-10 and the Port is planned to support the existing facilities. Alternative routes may be considered by the applicant for the extreme southern end of the Connector Road to establish a better tie in to the Port. The MSPA will also evaluate potential improvements to the rail lines between the port and I-10.

**EXISTING CONDITIONS:** The proposed construction for the restoration and revitalization is located in the Port of Gulfport. The project area is located in a highly industrialized and commercialized area of Gulfport. The project area includes marine facilities for fishing vessels, recreational vessels, a U.S. Coast Guard station and ocean-going freighters.

The Port of Gulfport is located on the north shore of Mississippi Sound. Mississippi Sound is a shallow estuary approximately 80 miles long by 9 miles wide which is separated from the Gulf of Mexico by a chain of barrier islands. Mississippi Sound has an average water depth of 10 feet, with over 99 percent of Mississippi Sound is less than 20 feet deep. The Port includes an East Terminal, Central Support Area, West Terminal and a Commercial Small Craft Harbor. The harbor basin is divided into the inner harbor (water depth of -32 feet) and the outer harbor (water depth -36 feet). One casino operates within the Port. Access to the Port is provided by a

Federally-maintained ship channel (water depth -36 feet) and a small craft channel (water depth - 8 feet). Located to the east of the Port is a recreational small craft harbor, yacht club, city park and a U.S. Coast Guard Station. A public beach is located to the west of the Port. The northern boundary of the Port is Highway 90.

**PROJECT PURPOSE:** The applicant stated the following for their project purpose and need: “The purpose of the proposed project is to restore the Port of Gulfport from severe damage sustained from Hurricane Katrina and to protect it from future damage while restoring the MSPA into a world class maritime facility. The enhancements to the Port would ensure it would be a large sustainable economic engine for the State of Mississippi. The proposed project will facilitate the revitalization of the existing port facility and related public infrastructure and facilities, minimize future storm damage by elevating the Port to +25’, provide for the long-term recovery of the operating capacity of the port and make jobs available to low-to-moderate-income workers. As a result of Hurricane Katrina, approximately \$5 billion in Federal aid was appropriated to the State of Mississippi to assist in recovery and rebuilding efforts. The MSPA was designated as a key element in these efforts and funds have been obligated to establish a sustainable port facility capable of repositioning itself in the maritime marketplace. The restoration of the Port is crucial to the economy and long-term recovery of the State of Mississippi and the Gulf Coast region in particular. The MSPA is responsible for the daily operations and infrastructure of the Port. Loss in operating capacity as a result of Hurricane Katrina has directly impacted the number of job opportunities at the Port. In 2005, before Hurricane Katrina, there were 3,200 direct, induced and indirect maritime jobs associated with the Port. Currently, there are 2,000. The Port of Gulfport Restoration Program provides funding to the MSPA to facilitate the restoration of public infrastructure and publicly-owned facilities destroyed by Hurricane Katrina, to minimize future damage to the Port and to provide for the long-term recovery and revitalization of the operating capacity of the Port.”

The Corps initially determined the basic project purpose is for the construction and revitalization of an existing port facility and would be considered a water dependent activity.

**ALTERNATIVES:** The agent representing the applicant stated alternatives to the proposed action will be considered. Additional evaluation of alternatives regarding the project as proposed would be evaluated throughout the review process by the Corps and cooperating agencies.

**MITIGATION:** The applicant stated the following for a compensatory mitigation concept: “A detailed mitigation plan will be developed during the permit and NEPA review process. The conceptual plan for development of the detailed mitigation plan includes using the Mississippi Coastal Improvements Program (MsCIP) and Mississippi Department of Marine Resources (DMR) Coastal Impact Assistance Program (CIAP) as resources. Coastal restoration projects evaluated under these programs, which were not chosen for implementation, will be considered for inclusion in the detailed mitigation plan for the proposed project. Other options include the possibility of enhancing coastal marshes located in the Hancock County Marshes Coastal Preserve, part of the State’s coastal preserve program, subsidizing the creation of near shore reefs, deployment of derelict vessels within the fish havens, clutch plants for existing oyster reefs, management of coastal preserves, acquisitions of new properties to be included in the coastal preserve program and testing dredged material for potential beneficial use. Other potential mitigation options recommended by the resource agencies and the public will also be considered

**for inclusion in the detailed plan. Finally, the MSPA's Environmental Consultant may recommend additional potential mitigation sites. A draft Conceptual Mitigation Plan will be developed and coordinated with the resource agencies for review and comment. The level of mitigation will likely be based on best professional judgment since there is currently no accepted methodology for evaluating water column and water bottom impacts".**

Final compensatory mitigation will be evaluated by the Corps and cooperating resource agencies throughout the review process for the proposed project.

The applicant has applied for certification from the State of Mississippi in accordance with Section 401(a) (1) of the Clean Water Act and upon completion of the required advertising, a determination relative to certification will be made.

The applicant has applied for coastal zone consistency from the State of Mississippi Department of Marine Resources in accordance with Section 57-15-6 of the Mississippi Code Annotated.

This public notice is being distributed to all known interested persons in order to assist in developing facts on which a decision by the Corps can be based. For accuracy and completeness of the record, all data in support of or in opposition to the proposed work should be submitted in writing setting forth sufficient detail to furnish a clear understanding of the reasons for support or opposition. The decision whether to issue a permit will be based on an evaluation of the probable impact, including cumulative impacts, of the proposed activity on the public interest. That decision will reflect the national concern for both protection and utilization of important resources.

The benefit which reasonably may be expected to accrue from the proposal must be balanced against its reasonably foreseeable detriments. All factors which may be relevant to the proposal will be considered, including the cumulative effects thereof; among those are conservation, economics, aesthetics, general environmental concerns, wetlands, cultural values, fish and wildlife values, protected species, flood hazards, flood plain values, land use, navigation, shoreline erosion and accretion, recreation, water supply and conservation, water quality, energy needs, safety, food production and in general, the needs and welfare of the people.

The Corps is soliciting comments from the public; Federal, State and local agencies and officials; Indian Tribes; and other interested parties in order to consider and evaluate the impacts of this proposed activity. Any comments received will be considered by the Corps to determine whether to issue, modify, condition or deny a permit for this proposal. To make this decision, comments are used to assess impacts on endangered species, historic properties, water quality, general environmental effects and the other public interest factors listed above. Comments are used in the preparation of an Environmental Assessment and/or an Environmental Impact Statement pursuant to the National Environmental Policy Act. Comments are also used to determine the need for a public hearing and to determine the overall public interest of the proposed activity. Any person may request, in writing, within the comment period specified in this notice, that a public hearing be held for consideration of this application. Requests for public hearings shall state with particularity, the reasons for holding a public hearing.

Evaluation of the probable impacts involving deposits of dredged or fill material into waters of the United States will include the application of guidelines established by the Administrator of the U.S. Environmental Protection Agency.

The National Register of Historic Places (NRHP) will be consulted for properties listed in or eligible for the National Register which would be affected by the proposed work. Copies of this notice are being sent to the State Historic Preservation Officer (SHPO) and the U.S. Department of the Interior, National Park Service, Division of Archeological Services for further consultation and comments. Previous investigations for the facility have determined that no properties are listed in or eligible for listing in the NRHP. In accordance with Appendix C of 33 CFR Part 325, the Corps has determined that the permit area is the full area of development for the overall project footprint. **The Corps will consult with in-house expertise and if needed the SHPO to make a final determination based upon this review unless comment to this notice is received documenting that significant sites or properties exist which may be affected by this work or that adequately documents that a potential exists for the location of significant sites or properties within the permit area.**

Preliminary review of this application and the U.S. Department of the Interior List of Endangered and Threatened Wildlife and Plants indicate the proposed activity **will require additional evaluation** on the species, Gulf Sturgeon. Further evaluation will be performed to determine the potential impact to critical habitat and/or additional species. The National Marine Fisheries Service (NMFS) requires the evaluation of impacts to Essential Fish Habitat (EFH) of estuarine species. This notice initiates the EFH **informal consultation notification** of the Magnuson-Stevens Fishery Conservation and Management Act. Further coordination with the NMFS and the U.S. Fish and Wildlife Service (FWS) will be performed on the proposed project. **Formal consultation with both the NMFS and the FWS may be required as additional information is gathered and coordination is performed.**

Correspondence concerning this Public Notice should refer to Public Notice Number **SAM-2009-01768-DMY** and should be directed to the District Engineer, U.S. Army Engineer District, Mobile, Attention: Mr. Damon M. Young, P.G., Post Office Box 2288, Mobile, Alabama 36628-0001, Attention: Coastal Branch, with a copy to the Mississippi Department of Environmental Quality, Office of Pollution Control, Attention: Ms. Florance Watson, P.E., Post Office Box 2261, Jackson, Mississippi 39225 and the Mississippi Department of Marine Resources, Attention: Ms. Jennifer Whittmann, 1141 Bayview Avenue, Suite 101, Biloxi, Mississippi 39530, in time to be received within **30 days** of the date of this public notice.

If you have any questions concerning this publication, you may contact the project manager for this application, **Mr. Damon M. Young, P.G.** (damon.m.young@usace.army.mil), phone **(251) 690-2658**. Please refer to the above Public Notice number.

For additional information about our Regulatory Program, please visit our web site at: [www.sam.usace.army.mil/rd/reg](http://www.sam.usace.army.mil/rd/reg) and please take a moment to complete our customer satisfaction survey while you're there. Your responses are appreciated and will allow us to improve our services.

MOBILE DISTRICT  
U.S. Army Corps of Engineers

Enclosures



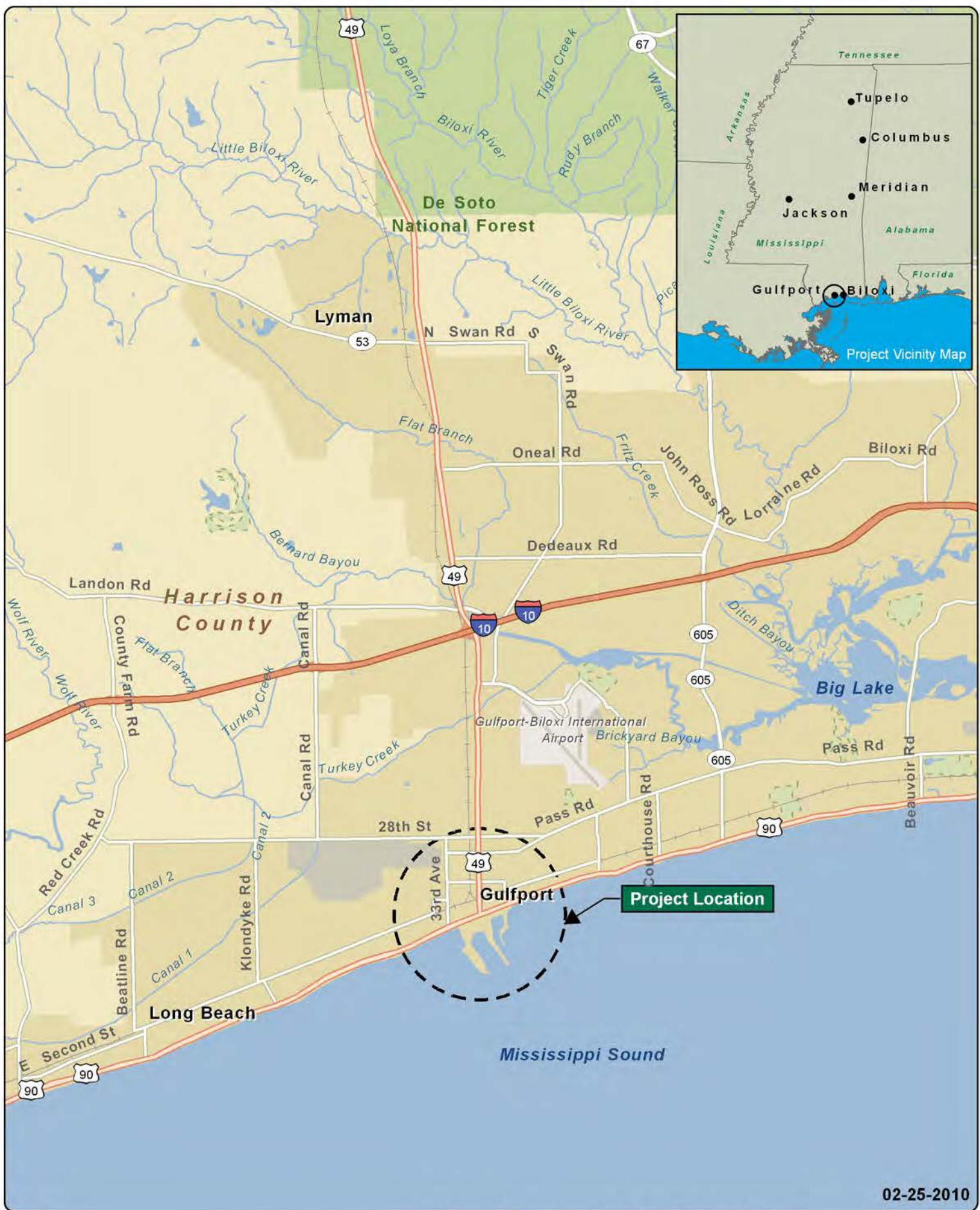

02-25-2010

**VOLKERT**

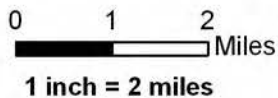

Note: This map is for presentation use only and not to be used for construction purposes.

**PORT OF GULFPORT RESTORATION PROGRAM** **Figure 1**  
Project Vicinity Map





As Built Channel

24 Acres  
30 Acres  
30 Acres

**Legend**

-  84 - Acre Permitted Fill Area (MS96 - 02828 - U)
-  Permitted Dredging Areas (SAM - 2009 - 0433 - JBM)
-  Gulfport Harbor Federal Channel & Turning Basin
-  Yacht Club Channel

02-25-2010

**VOLKERT**

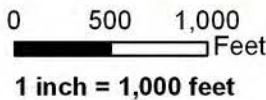

Note: This map is for presentation use only and not to be used for construction purposes.

**PORT OF GULFPORT RESTORATION PROGRAM**

**Figure 2 Existing Port**



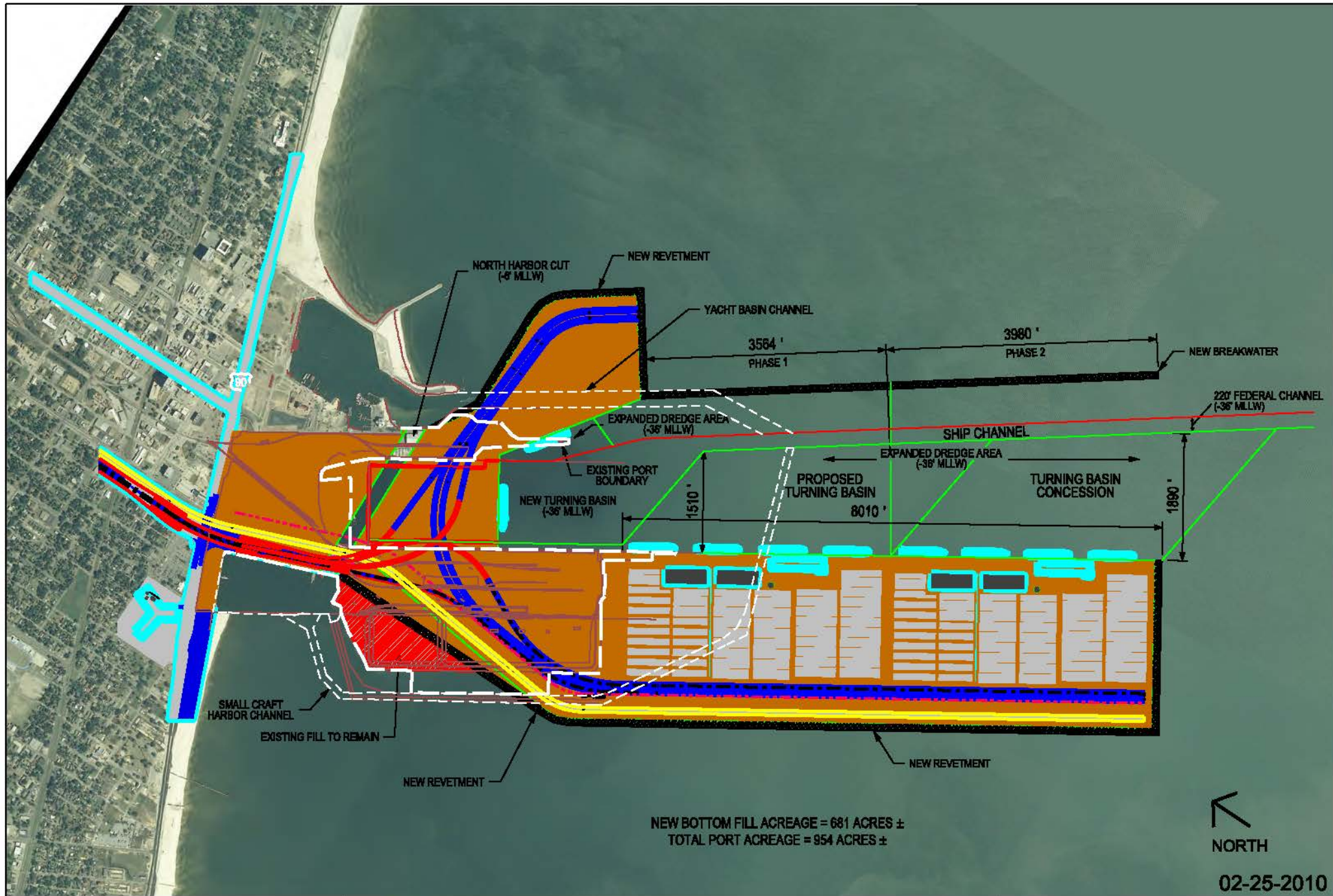

**VOLKERT**



**PORT OF GULFPORT  
RESTORATION  
PROGRAM**

NOTE:  
SCALE = 1" = 1800'

**FIGURE 3  
PROPOSED PLAN**

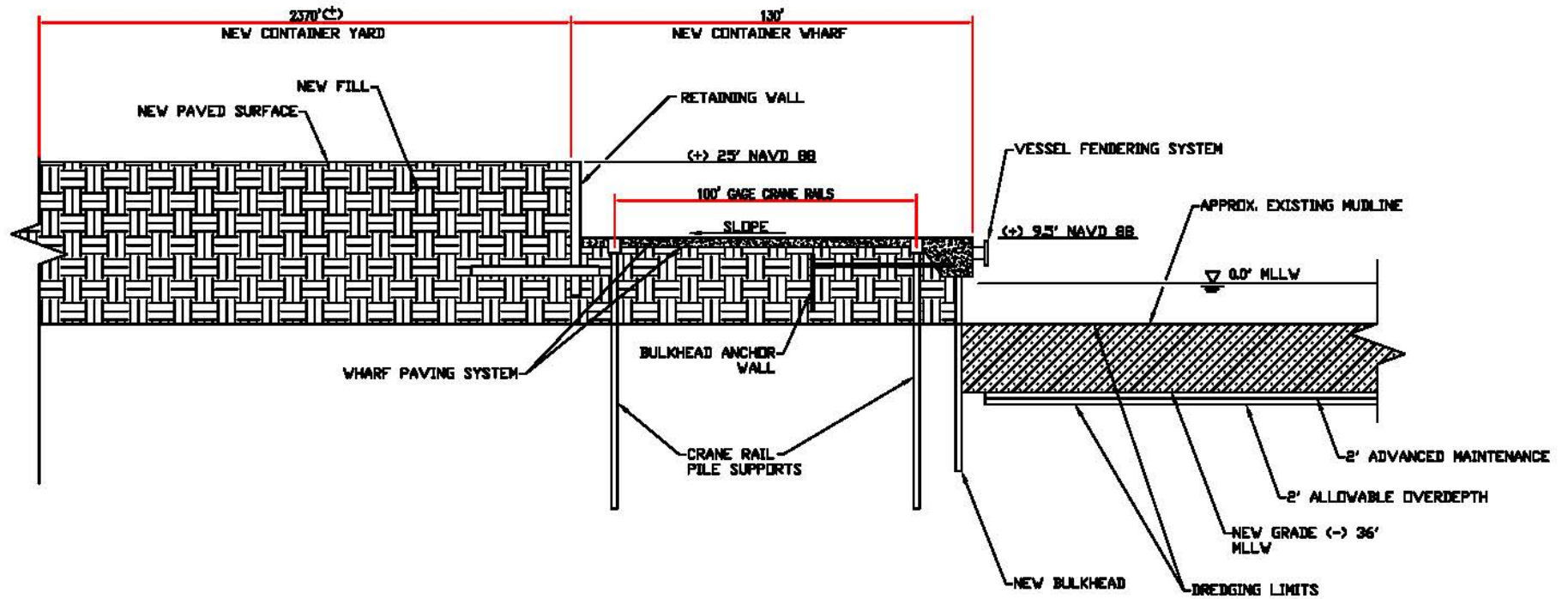

02-25-2010

**VOLKERT**

SCALE:  
1" = 50'



PORT OF GULFPORT  
RESTORATION  
PROGRAM

FIGURE 4  
TYPICAL WHARF AND  
FILL CROSS SECTION

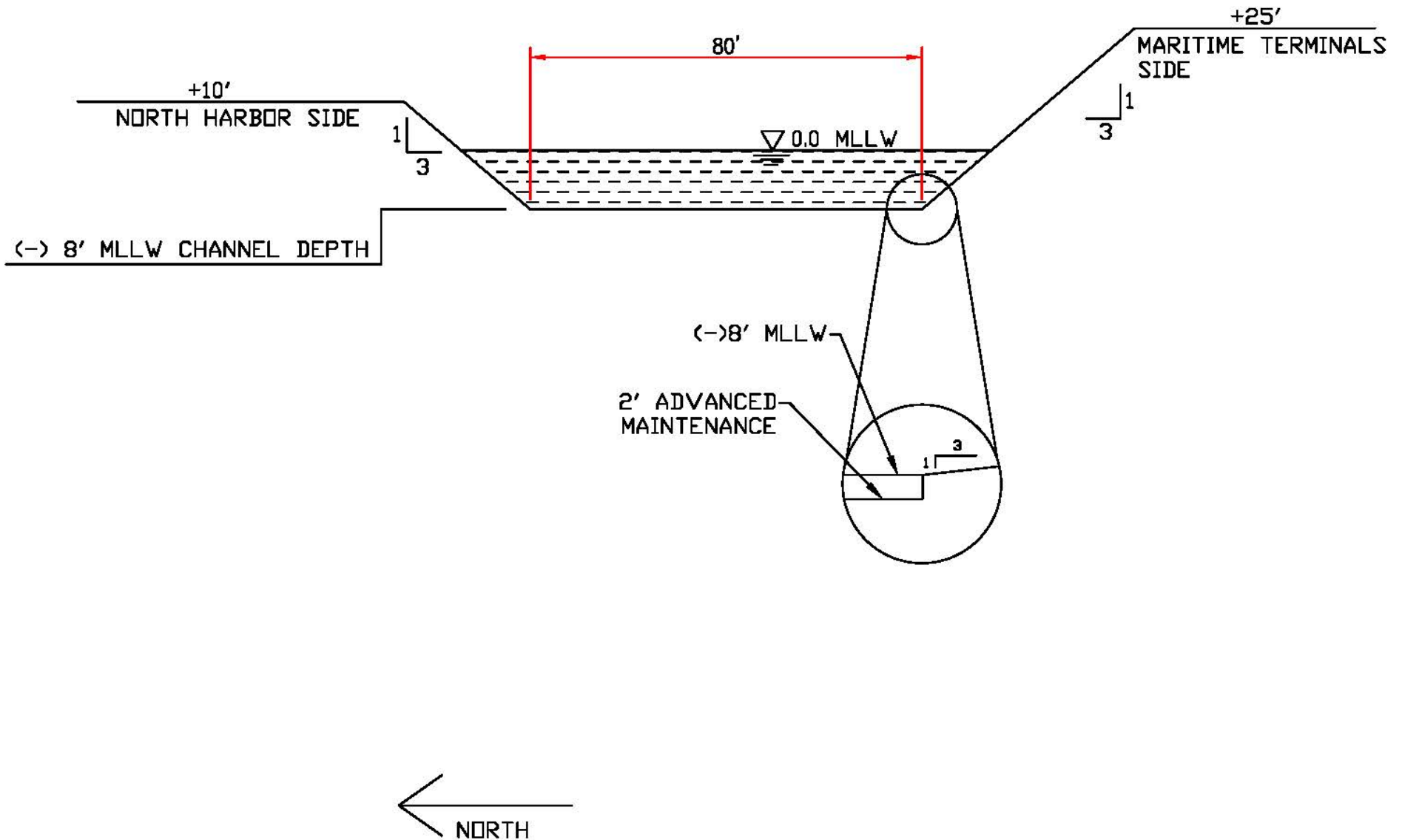

02-25-2010

**VOLKERT**

SCALE:  
1" = 30'



PORT OF GULFPORT  
RESTORATION  
PROGRAM

FIGURE 5  
NORTH HARBOR CUT  
TYPICAL CHANNEL  
CROSS SECTION



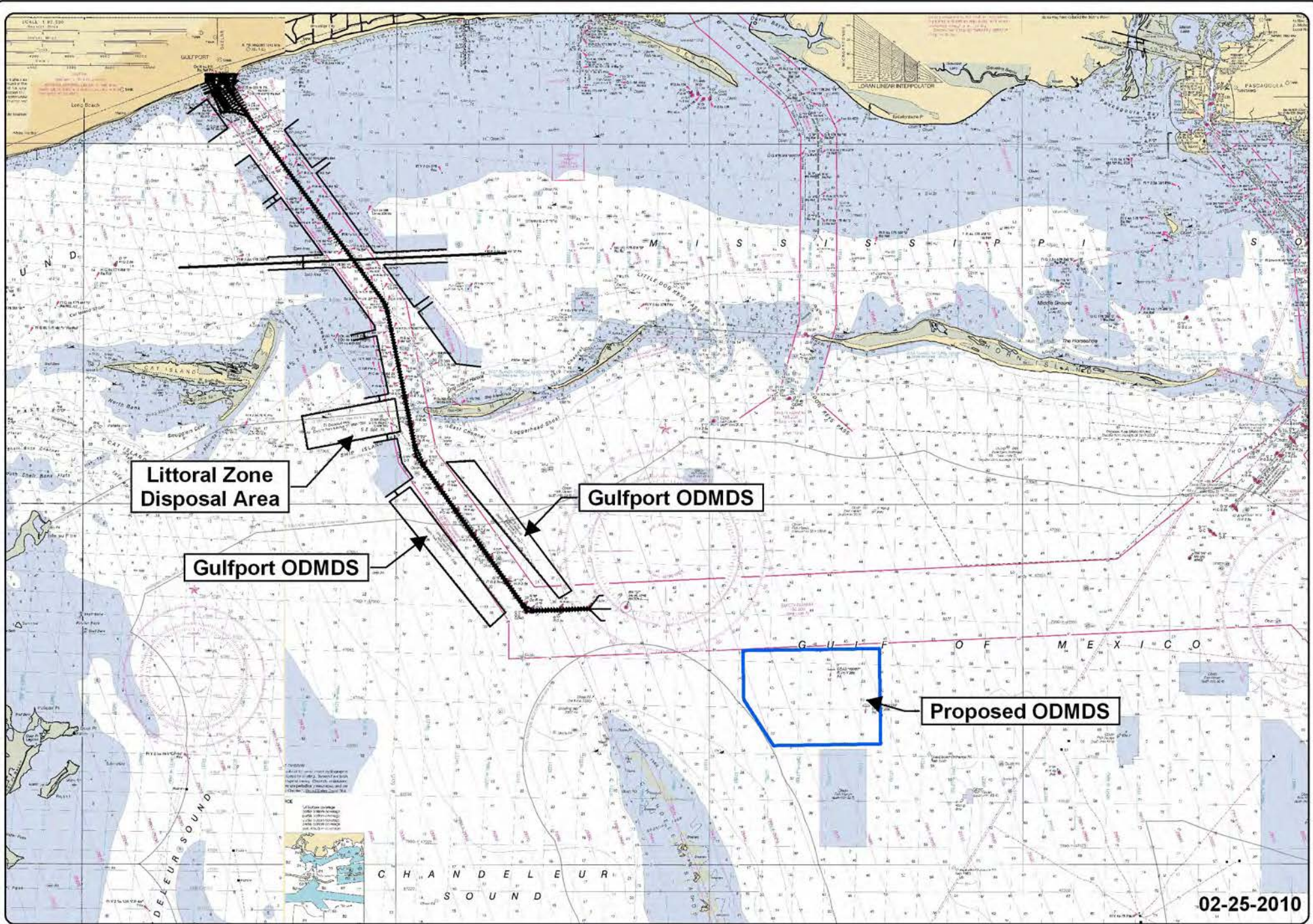

02-25-2010

Note: This map is for presentation use only and not to be used for construction purposes.

**VOLKERT**

0 2 4 Miles  
1 inch = 4 miles



**PORT OF GULFPORT  
RESTORATION PROGRAM**

**Figure 6  
Ocean Dredge Material Disposal Sites  
and Littoral Zone Disposal Area**



NOTE:

APPROXIMATELY 7,590 LF OF NEW  
BREAKWATER REQUIRED.

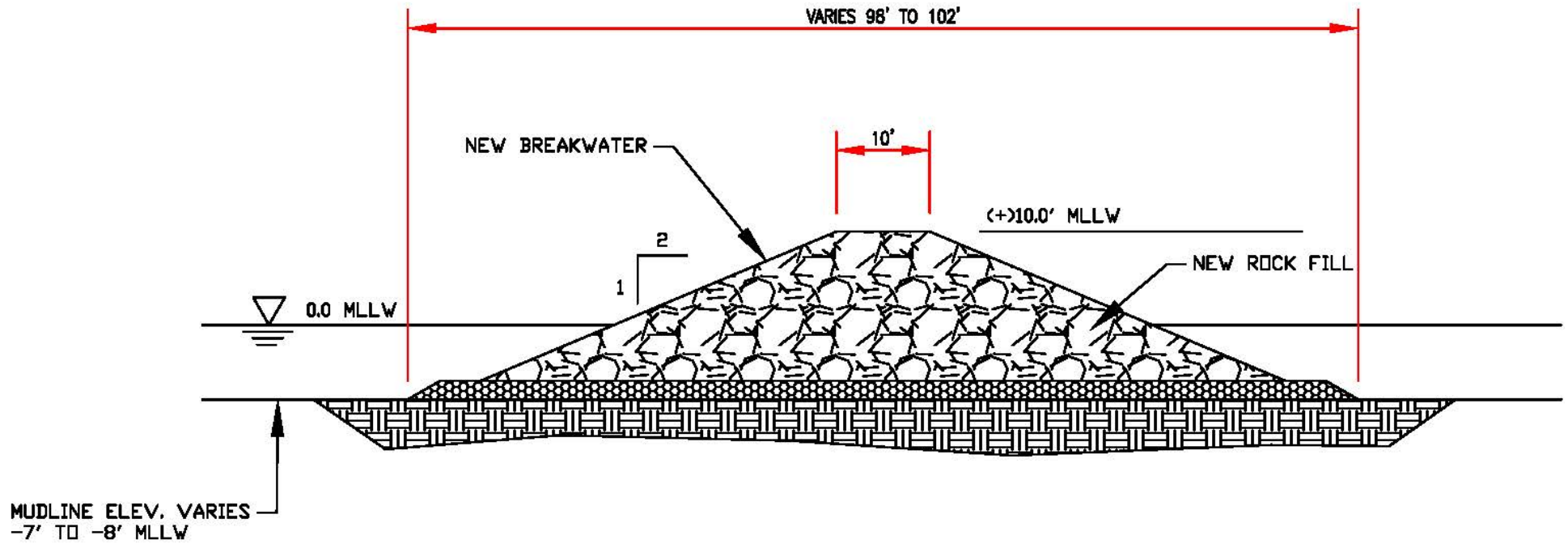

02-25-2010

**VOLKERT**

SCALE:  
1" = 20'



PORT OF GULFPORT  
RESTORATION  
PROGRAM

FIGURE 7  
TYPICAL BREAKWATER  
SECTION



**Appendix A3**

***Federal Register* Notice of Intent**

**March 11, 2011**





services listed below from nonprofit agencies employing persons who are blind or have other severe disabilities.

#### Regulatory Flexibility Act Certification

I certify that the following action will not have a significant impact on a substantial number of small entities. The major factors considered for this certification were:

1. If approved, the action will not result in any additional reporting, recordkeeping or other compliance requirements for small entities other than the small organizations that will furnish the services to the Government.

2. If approved, the action will result in authorizing small entities to furnish the services to the Government.

3. There are no known regulatory alternatives which would accomplish the objectives of the Javits-Wagner-O'Day Act (41 U.S.C. 46–48c) in connection with the services proposed for addition to the Procurement List.

Comments on this certification are invited. Commenters should identify the statement(s) underlying the certification on which they are providing additional information.

#### End of Certification

The following services are proposed for addition to Procurement List for production by the nonprofit agencies listed:

#### Services

*Service Type/Location:* Base Supply Center, Rock Island Arsenal, 3154 Rodman Avenue, Rock Island, IL.

*NPA:* Association for Retarded Citizens of Rock Island County, Rock Island, IL.

*Contracting Activity:* DEPT OF THE ARMY, SR W0K8 USA ROCK ISL ARSENAL, ROCK ISLAND, IL.

*Service Type/Location:* Base Operations Support, Mark Center Campus, Alexandria, VA.

*NPA:* Service Source Inc., Alexandria, VA (prime); CW Resources Inc., New Britain, CT (subcontractor); Able Forces, Front Royal, VA (subcontractor).

*Contracting Activity:* Department of Defense, Acquisition Directorate, Washington Headquarters Service, Washington, DC.

*Service Type/Location:* Central Issue Facility Service, Fort Hood, TX.

*NPA:* Skookum Educational Programs, Bremerton, WA.

*Contracting Activity:* Department of the Army, Mission & Installation Contracting Command Center, Fort Sam Houston, TX.

*Service Type/Location:* Mail Management Support Service, Philadelphia Naval Business Center, Official Mail Center Carderock, Philadelphia, PA.

*NPA:* NewView Oklahoma, Inc., Oklahoma City, OK (prime); ServiceSource, Inc., Alexandria, VA (subcontractor); Naval Surface Warfare Center, Carderock Division, Ship Systems Engineering

Station, Official Mail Center Carderock, West Bethesda, MD.

*NPA:* NewView Oklahoma, Inc., Oklahoma City, OK.

*Contracting Activity:* Department of the Navy, Commander, Fleet and Industrial Supply Center, San Diego, CA.

#### Deletion

#### Regulatory Flexibility Act Certification

I certify that the following action will not have a significant impact on a substantial number of small entities. The major factors considered for this certification were:

1. If approved, the action will not result in additional reporting, recordkeeping or other compliance requirements for small entities.

2. If approved, the action may result in authorizing small entities to furnish the service to the Government.

3. There are no known regulatory alternatives which would accomplish the objectives of the Javits-Wagner-O'Day Act (41 U.S.C. 46–48c) in connection with the service proposed for deletion from the Procurement List.

#### End of Certification

The following service is proposed for deletion from the Procurement List:

#### Service

*Service Type/Location:* Recycling Service, Veterans Affairs Medical Center, 1500 East Woodrow Wilson Drive, Jackson, MS.

*NPA:* Goodwill Industries of Mississippi, Inc., Ridgeland, MS.

*Contracting Activity:* Department of Veterans Affairs, NAC, Hines, IL.

#### Patricia Briscoe,

*Deputy Director, Business Operations.*

[FR Doc. 2011–5616 Filed 3–10–11; 8:45 am]

**BILLING CODE 6353–01–P**

## CONSUMER PRODUCT SAFETY COMMISSION

### Sunshine Act Meeting Notice

**TIME AND DATE:** Wednesday, March 16, 2011; 10 a.m.–11 a.m.

**PLACE:** Hearing Room 420, Bethesda Towers, 4330 East West Highway, Bethesda, Maryland.

**STATUS:** Closed to the Public.

**MATTER TO BE CONSIDERED:**  
*Compliance Status Report*

The Commission staff will brief the Commission on the status of compliance matters. For a recorded message containing the latest agenda information, call (301) 504–7948.

**CONTACT PERSON FOR MORE INFORMATION:**  
Todd A. Stevenson, Office of the Secretary, U.S. Consumer Product

Safety Commission, 4330 East West Highway, Bethesda, MD 20814, (301) 504–7923.

Dated: March 8, 2011.

**Todd A Stevenson,**  
*Secretary.*

[FR Doc. 2011–5777 Filed 3–9–11; 4:15 pm]

**BILLING CODE 6355–01–P**

## DEPARTMENT OF DEFENSE

### Department of the Army, Corps of Engineers

#### Intent To Prepare an Environmental Impact Statement for the Port of Gulfport Expansion Project, Harrison County, MS (Department of the Army Permit Number SAM–2009–1768–DMY)

**AGENCY:** U.S. Army Corps of Engineers, DoD.

**ACTION:** Notice of intent.

**SUMMARY:** The U.S. Army Corps of Engineers, Mobile District (USACE) announces its intent to prepare an Environmental Impact Statement (EIS) to assess the potential environmental impacts associated with the construction and operation of a project proposed by the Mississippi State Port Authority (MSPA). As part of the NEPA process, the Mississippi Development Authority (MDA) will be a cooperating agency in the preparation of the EIS. The National Marine Fisheries Service (NMFS) has expressed interest in acting as a cooperating agency in the preparation of the EIS.

The proposed project as described in the application filed on March 17, 2010, proposed filling approximately 700 acres of open-water benthic habitat. Since submittal of the application, the proposed project footprint has been modified by the MSPA to reduce the overall potential fill required for implementation and to not include any impacts to the Gulfport Harbor Federal Navigation Channel or Turning Basin. The currently proposed project involves filling of up to 400 acres of open-water bottom in the Mississippi Sound, the construction of wharfs, bulkheads, terminal facilities, container storage areas, intermodal container transfer facilities, dredging and dredged material disposal and infrastructure, and construction of a breakwater of approximately 4,000 linear feet. The proposed expanded port facility will be elevated 25 feet above sea level to provide protection against future tropical storm surge events.

The EIS will evaluate the potential impacts of the proposed project, connected actions, and alternatives. The

EIS will also assist the USACE in deciding whether to issue a Department of the Army permit.

The purpose of this Notice of Intent (NOI) is to inform and educate the public of the proposed project; invite public participation in the EIS process; announce the plans for a public scoping meeting; solicit public comments for consideration in establishing the scope and content of the EIS; and provide notice of potential impacts to open-water benthic habitats.

**DATES:** A scoping meeting will be held on March 31, 2011. Comments will be accepted in written format at the scoping meeting or via mail/e-mail until April 11, 2011, to ensure consideration. Late comments will be considered to the extent practicable.

**ADDRESSES:** The scoping meeting will be held at the Fleming Education Center Auditorium at the University of Southern Mississippi's Gulf Park Campus, 730 East Beach Boulevard, Long Beach, Mississippi. Written comments regarding the proposed EIS scope should be addressed to Mr. Damon M. Young, P.G. USACE, Mobile District, Post Office Box 2288, Mobile, Alabama 36628. Individuals who would like to electronically provide comments should contact Mr. Young by electronic mail: [port.gulfporteis@usace.army.mil](mailto:port.gulfporteis@usace.army.mil).

**FOR FURTHER INFORMATION CONTACT:** For information about this project, to be included on the mailing list for future updates and meeting announcements, or to receive a copy of the DRAFT EIS when it is issued, contact Damon M. Young, P.G., at the USACE at (251) 690-2658 or the address provided above. Mr. Ewing Milam, at the MDA can also be contacted for additional information at P.O. Box 849, Jackson, Mississippi, 39205-0849, telephone 601.359.2157 or by electronic mail at [emilam@mississippi.org](mailto:emilam@mississippi.org).

**SUPPLEMENTARY INFORMATION:**

1. *Background:* The Gulfport Harbor Navigation Project was adopted by the River and Harbors Act approved on July 3, 1930 (House Document Number 692, 69th Congress, 2nd session) and the River and Harbors Act approved on June 30, 1948 (House Document Number 112, 81st Congress, 1st session). Construction of the existing Gulfport Harbor commenced in 1932 and was completed in 1950. Authorization to conduct improvements to the existing harbor was issued in the Fiscal Year 1985 Supplemental Appropriations Act (Public Law 99-88). The Water Resources Development Acts (WRDAs) 1986 and 1988 further modified the previous authorization to cover widening and deepening and thin-layer

disposal, respectively. The authorized deepening was completed in 1993. Currently, there is an ongoing Federal action to widen the channel to the Federally authorized dimensions of 300 feet in the Mississippi Sound Channel and 400 feet in the Bar Channel. A Department of the Army Permit MS96-02828-U was issued in 1998 authorizing an 84-acre expansion to fill the West Pier to construct new tenant terminals and infrastructure. Phases I and II are currently under construction. Phase III is expected to begin in late 2011.

On August 29, 2005, Hurricane Katrina made landfall on the Mississippi Gulf Coast, resulting in one of the most significant natural disasters in the United States. The Port of Gulfport was severely impacted by the storm. The electrical power supply, roads, water, sewer, rail, small craft harbor fendering systems, navigational aids, and lighting and security systems were all destroyed or damaged beyond repair. According to the MSPA, the Port is currently operational at this time but it is not capable of withstanding another major hurricane without significant rehabilitation.

2. *Location:* The proposed Port of Gulfport Expansion Project is located in the City of Gulfport, Harrison County, Mississippi. The proposed project is approximately 80 miles west of Mobile, Alabama, and 80 miles east of New Orleans, Louisiana. The Port encompasses approximately 184 acres and is located within 5 miles of the Gulf Intracoastal Waterway (GIWW) and approximately 7 miles south of Interstate Highway 10.

3. *Work:* The proposed project involves filling of up to 400 acres of open-water bottom in the Mississippi Sound, the construction of wharfs, bulkheads, terminal facilities, container storage areas, intermodal container transfer facilities, dredging and dredged material disposal and infrastructure, construction of a breakwater of approximately 4,000 linear feet, and may include additional improvements identified at the public scoping meeting. The proposed expanded port facility will be elevated 25 feet above sea level to provide protection against future tropical storm surge events. A Department of the Army permit is required for the proposed project, pursuant to Section 404 of the Clean Water Act (33 U.S.C. 1251), Section 10 of the River and Harbors Act (33 U.S.C. 403), and Section 103 of the Marine Protection, Research, and Sanctuaries Act (33 U.S.C. 1401-1445, 16 U.S.C. 1431 *et seq.*, also 33 U.S.C. 1271).

An Environmental Impact Statement (EIS) will be prepared pursuant to the

National Environmental Policy Act (NEPA) of 1969, as amended (42 U.S.C. 4321 *et seq.*), and the Council on Environmental Quality NEPA regulations (40 CFR parts 1500-1508) to assess the potential environmental impacts associated with the construction and operation of a project proposed by the Mississippi State Port Authority (MSPA).

4. *Need:* According to the MSPA, this project will enhance Mississippi's standing in the global economy by repositioning the Port into a sustainable, world-class maritime facility for future generations. This project is needed to expand the Port's current footprint, which will include the construction of wharfs, bulkheads, terminal facilities, container storage areas, intermodal container transfer facilities, dredging and dredged material disposal and infrastructure. Specific alternatives will be developed as part of the EIS process and feedback provided during project scoping.

5. *Affected Environment:* Environmental characteristics that may be affected by the proposed project include geological, chemical, biological, physical, socioeconomic, and commercial and recreational activities. Offshore, the navigation channel extends 20 miles south into the Gulf of Mexico, passing close to the western end of Ship Island. On-shore, the regional environment is characterized as Coastal Lowlands, and the shore area, where not developed, consists typically of gently undulating swampy plains. The beach area is man-made and bordered by constructed seawalls. The existing Port, as part of the man-made environment of Gulfport, is constructed on fill material. The Gulfport area is well developed. Beyond the seawalls are extensive commercial and residential developments. The near-shore area is known for its valuable resources as a productive fishery and is also utilized extensively for commercial and recreational shipping and boating.

6. *Applicable Environmental Laws and Policies:* The proposed project could result in both beneficial and negative environmental impacts. These impacts will be evaluated in the EIS in accordance with applicable environmental laws and policies, which include NEPA; WRDA; Endangered Species Act (ESA); Clean Water Act; Clean Air Act; U.S. Fish and Wildlife Coordination Act; National Historic Preservation Act; Coastal Barrier Resources Act; Magnuson-Stevens Fishery Conservation and Management Act; Coastal Zone Management Act; Marine, Protection, Research, and Sanctuaries Act; Rivers and Harbors

Act; National Marine Sanctuaries Act; Fishery Conservation Act; Marine Mammal Protection Act; Executive Order 12898, Environmental Justice in Minority Populations and Low-Income Populations; Executive Order 13045, Protection of Children from Environmental Health Risks and Safety Risk (among other Executive Orders); and Ports and Waterways Safety Act.

7. *Preliminary Identification of Environmental Issues*: The following list of nine environmental issues has been tentatively identified for analysis in the EIS. This list, which was developed during preliminary internal scoping, has been included with the permit application filed for the proposed project. This list (and information from similar projects) is neither intended to be all inclusive nor a predetermined set of potential impacts, but is presented to facilitate public comment on the planned scope of the EIS. Additions to or deletions may occur as a result of the public scoping process. Preliminary identified environmental issues include but are not limited to the loss of aquatic resource (impact to potential submerged and shoreline aquatic habitat); water quality, coastal zone consistency, hydrodynamic modeling, threatened and endangered species (including critical habitat and essential fish and shellfish habitat), air quality, alternatives, secondary and cumulative impacts, socioeconomics, and mitigation.

8. *Scoping meeting*: To ensure that all of the issues related to this proposed project are addressed, the USACE will conduct a public scoping meeting in which agencies, organizations, and members of the general public are invited to present comments or suggestions with regard to the range of actions, alternatives, and potential impacts to be considered in the EIS. The scoping meeting will be held at the Fleming Education Center Auditorium at the University of Southern Mississippi's Gulf Park Campus, 730 East Beach Boulevard, Long Beach, Mississippi, on March 31, 2011. The scoping meeting will begin with an informal open house from 5:30 p.m. to 6:30 p.m. followed by a formal presentation of the proposed action and a description of the NEPA process. Comments will be accepted following the formal presentation until 8 p.m. Displays and other forms of information about the proposed action will be available, and the USACE, the MSPA and the MDA personnel will be present at the informal session to discuss the proposed project and the EIS Process. The USACE invites comments on the proposed scope and content of the EIS

from all interested parties. Verbal transcribers will be available at the scoping meeting to accept verbal comments following the formal presentation until 8:00 p.m. A time limit will be imposed on verbal comments.

9. *DRAFT EIS*: It is anticipated that a DRAFT EIS will be made available for public review in late calendar year 2011 or early 2012.

Dated: February 24, 2011.

**Craig J. Litteken,**  
Chief, Regulatory Division.

[FR Doc. 2011-5672 Filed 3-10-11; 8:45 am]

**BILLING CODE 3720-58-P**

## DEPARTMENT OF EDUCATION

### **Credit Enhancement for Charter School Facilities Program; Office of Innovation and Improvement; Overview Information; Credit Enhancement for Charter School Facilities Program; Notice Inviting Applications for New Awards for Fiscal Year (FY) 2011**

Catalog of Federal Domestic Assistance (CFDA) Number: 84.354A.

*Dates:*

*Applications Available:* March 11, 2011.

*Date of Pre-Application Meeting:* April 4, 2011 at 9:00 a.m., Washington, DC time.

*Deadline for Transmittal of Applications:* May 10, 2011.

*Deadline for Intergovernmental Review:* July 9, 2011.

#### **Full Text of Announcement**

##### **I. Funding Opportunity Description**

*Purpose of Program*: This program provides grants to eligible entities to permit them to enhance the credit of charter schools so that the charter schools can access private-sector and other non-Federal capital in order to acquire, construct, and renovate facilities at a reasonable cost. Grants awarded under this program will be of sufficient size, scope, and quality to enable the grantees to implement effective strategies for reaching this objective.

*Priorities*: This competition includes one competitive preference priority and one invitational priority that are explained in the following paragraphs. In accordance with 34 CFR 75.105(b)(2)(ii), the competitive preference priority is from the regulations for this program (34 CFR 225.12).

*Competitive Preference Priority*: For FY 2011 and any subsequent year in which we make awards from the list of

unfunded applicants from this competition, this priority is a competitive preference priority. Under 34 CFR 75.105(c)(2)(i) we award up to an additional 15 points to an application, depending on how well the application meets this priority.

This priority is:

The capacity of charter schools to offer public school choice in those communities with the greatest need for school choice based on—

(1) The extent to which the applicant would target services to geographic areas in which a large proportion or number of public schools have been identified for improvement, corrective action, or restructuring under Title I of the Elementary and Secondary Education Act of 1965, as amended (ESEA);

(2) The extent to which the applicant would target services to geographic areas in which a large proportion of students perform below proficient on State academic assessments; and

(3) The extent to which the applicant would target services to communities with large proportions of students from low-income families.

*Invitational Priority*: For FY 2011 and any subsequent year in which we make awards from the list of unfunded applicants from this competition, this priority is an invitational priority. Under 34 CFR 75.105(c)(1) we do not give an application that meets this priority a competitive or absolute preference over other applications.

This priority is:

Applications that propose a grant project that uses competitive market forces to obtain the best rates and terms on financing for charter schools in order for the charter schools to acquire, construct, and renovate facilities while using the least amount of grant funds.

*Program Authority*: 20 U.S.C. 7223-7223j.

*Applicable Regulations*: (a) The Education Department General Administrative Regulations (EDGAR) in 34 CFR parts 74, 75, 77, 79, 80, 81, 82, 84, 85, 86, 97, 98, and 99. (b) The regulations for this program in 34 CFR part 225.

**Note**: The regulations in 34 CFR part 79 apply to all applicants except federally recognized Indian tribes.

**Note**: The regulations in 34 CFR part 86 apply to institutions of higher education only.

##### **II. Award Information**

*Type of Award*: Discretionary grants.  
*Estimated Available Funds*: The Administration's budget request for FY 2011 does not include funds for this



**Appendix A4**

**Permit Application Modification**

**April 8, 2013**





## MISSISSIPPI STATE PORT AUTHORITY AT GULFPORT

JOHN K. RESTER  
Commissioner  
ROBERT J. KNESAL  
Commissioner  
JAMES C. SIMPSON, JR.  
Commissioner

JACK NORRIS  
Commissioner  
E.J. ROBERTS  
Commissioner  
MATTHEW S. WYPYSKI  
Interim Director & CEO  
[www.shipmspa.com](http://www.shipmspa.com)

April 8, 2013

Mr. Damon M. Young, Regulatory Division  
U.S. Army Corps of Engineers  
Mobile District  
Post Office Box 2288  
Mobile, Alabama 36628-0001

RE: Department of the Army Permit Application SAM-2009-1768-DMY

Dear Mr. Young:

The Mississippi State Port Authority (MSPA) has discussed internally the option of adding the Federal Navigation Channel (FNC) to the Third Party Environmental Impact Statement (EIS) currently being prepared to meet the long-term throughput goals of the Port. The goal of MSPA is to build a maximum efficiency port facility capable of handling a container traffic volume of two million twenty-foot equivalent units (TEUs) per year. This could be accomplished with the current EIS alternative for maximum efficiency and a deeper FNC; as such there is a need to revise the original permit application to include a deeper FNC.

Supporting details for the update to the permit application are contained in the attached revised permit application form and addendum information. The proposed maximum efficiency project will contribute substantially to achieving a robust facility that is capable of increasing throughput consistent with goals of MSPA to stimulate economic growth and produce additional employment opportunities.

If you have any questions regarding this request or if you need more information please contact me at 228-865-4300. Thank you for your assistance with this extremely important project for the State of Mississippi.

Sincerely,

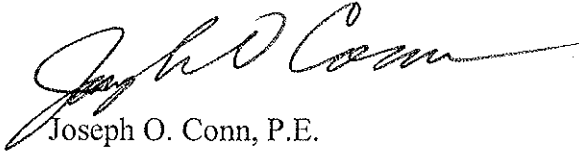
A handwritten signature in black ink, appearing to read "Joseph O. Conn". The signature is fluid and cursive, with a long horizontal stroke at the end.

Joseph O. Conn, P.E.  
Director, Port Restoration

Cc: Bureau of Wetlands Permitting, Department of Marine Resources  
Director, Mississippi Department of Environmental Quality  
Ewing Milam, Mississippi Development Authority  
N. D. "Skeeter" McClure, Volkert, Inc.  
Elizabeth Calvit, CH2M HILL

Attachments



# JOINT APPLICATION AND NOTIFICATION

**U.S. ARMY CORPS OF ENGINEERS  
MISSISSIPPI DEPARTMENT OF MARINE RESOURCES  
MISSISSIPPI DEPARTMENT OF ENVIRONMENTAL QUALITY/OFFICE OF POLLUTION CONTROL**

This form is to be used for proposed activities in waters of the United States in Mississippi and for the erection of structures on suitable sites for water dependent industry. Note that some items, as indicated, apply only to projects located in the coastal area of Hancock, Harrison and Jackson Counties.

**1. Date** 04 05 2013

~~03 09 2010~~  
month day year

<b>2. Applicant name, mailing address, phone number and email address:</b> Mississippi State Port Authority P.O. Box 40 Gulfport, Mississippi 39502 (228) 865-4300 jconn@shipmspa.com Attn: Joe Conn	<b>Agent name, mailing address, phone number and email address:</b> <del>Volkert, Inc.</del> same as applicant <del>P.O. Box 7434</del> <del>Mobile, Alabama 36670</del> <del>(251) 342-1070</del> <del>hmalec@volkert.com</del>	<b>3. Official use only</b> COE _____ DMR _____ DEQ _____ A95 _____ DATE RECEIVED _____
--	---	--

**4. Project location** 30th Avenue at U.S 90 City/Community Gulfport

Street Address \_\_\_\_\_ City/Community \_\_\_\_\_

Name of Waterway Mississippi Sound Latitude 30° 21' 40.28" N Longitude (if known) 89° 05' 49.99" W

Geographic location: Section 9 Township 8 S Range 11 W County Harrison

**5. Project description**

New work  Maintenance work

**Dredging**

<input checked="" type="checkbox"/> Channel	length <u>See Attached</u>	width <u>See Attached</u>	existing depth <u>See Attached</u>	proposed depth <u>See Attached</u>
<input type="checkbox"/> Canal	length _____	width _____	existing depth _____	proposed depth _____
<input type="checkbox"/> Boat Slip	length _____	width _____	existing depth _____	proposed depth _____
<input type="checkbox"/> Marina	length _____	width _____	existing depth _____	proposed depth _____
<input type="checkbox"/> Other-Mooring Basin	length _____	width _____	existing depth _____	proposed depth _____

Cubic yards of material to be removed ~~48,280,000~~ 44,755,000 Type of material sand/silt/clay

Location of spoil disposal area Within fill area, Littoral Zone Disposal Area Southeast of Cat Island, Gulfport ODMSDs (See attached)

Dimensions of spoil area See attached. Method of excavation Mechanical and/or Hydraulic Dredge

How will excavated material be contained? Earth containment dike

**Construction of structures**

<input checked="" type="checkbox"/> Bulkhead	Total length <del>13,730'</del> <u>3,500'</u>	Height above water <u>9.5'</u>
<input checked="" type="checkbox"/> Pier	length <del>12,660'</del> <u>3,500'</u>	width <u>130'</u> height <u>9.5'</u>
<input type="checkbox"/> Boat Ramp	length _____	width _____ slope _____
<input type="checkbox"/> Boat House	length _____	width _____ height _____

Structures on designed sites for water dependent industry (Coastal area only). Explain in item 11 or include as attachment. 12,660' 3,500' of retaining wall to +25', 22,160 5,500' feet of shoreline revetment and 7,590 4,000' linear feet of

Other (explain) breakwater

**Filling**

Dimensions of fill area ~~701~~ 200 acres of water bottoms

Cubic yards of fill ~~39,500,000~~ 13,200,000 Type of fill sand, silts and clays

**Other regulated activities (i.e. Seismic exploration, burning or clearing of marsh) Explain.**

\_\_\_\_\_

\_\_\_\_\_

\_\_\_\_\_

**6. Additional information relating to the proposed activity**

Does project area contain any marsh vegetation? Yes  No

(If yes, explain) \_\_\_\_\_

Is any portion of the activity for which authorization is sought now complete? Yes  No

(If yes, explain) See attached.

Month and year activity took place On-going

If project is for maintenance work on existing structures or existing channels, describe legal authorization for the existing work. Provide permit number, dates or other form(s) of authorization. NA

Has any agency denied approval for the activity described herein or for any activity that is directly related to the activity described herein?

Yes  No  (If yes, explain) \_\_\_\_\_

**7. Project schedule**

Proposed start date ~~12/31/12~~ 1/1/2016 Proposed completion date 12/31/19

Expected completion date (or development timetable) for any projects dependent on the activity described herein. \_\_\_\_\_

**8. Estimated cost of the project** ~~\$570 Million~~ \$700 Million

**9. Describe the purpose of this project. Describe the relationship between this project and any secondary or future development the project is designed to support.** See attached.

Intended use: Private  Commercial  Public  Other (Explain) \_\_\_\_\_

**10. Describe the public benefits of the proposed activity and of the projects dependent on the proposed activity.**

**Also describe the extent of public use of the proposed project.**

See attached.

**11. Narrative Project Description:**

See attached.

---

12. Provide the names and addresses of the adjacent property owners. Also identify the property owners on the plan view of the drawing described in Attachment "A". (Attach additional sheets if necessary.)

1. See attached.

2.

---

13. List all approvals or certifications received or applied for from Federal, State and Local agencies for any structures, construction, discharges, deposits or other activities described in this application. Note that the signature in Item 14 certifies that application has been made to or that permits are not required from the following agencies. If permits are not required, place N/A in the space for Type Approval.

<u>Agency</u>	<u>Type Approval</u>	<u>Application Date</u>	<u>Approval Date</u>
Dept. of Environmental Quality	Water Quality Certification	March 9, 2010	
Dept. of Marine Resources	Coastal Zone Consistency	March 9, 2010	
Army Corps of Engineers	Section 10 and 404	March 9, 2010	
City/County_____			
Other_____			

---

**14. Certification and signatures**

Application is hereby made for authorization to conduct the activities described herein. I agree to provide any additional information/data that may be necessary to provide reasonable assurance or evidence to show that the proposed project will comply with the applicable state water quality standards or other environmental protection standards both during construction and after the project is completed. I also agree to provide entry to the project site for inspectors from the environmental protection agencies for the purpose of making preliminary analyses of the site and monitoring permitted works. I certify that I am familiar with and responsible for the information contained in this application, and that to the best of my knowledge and belief, such information is true, complete and accurate. I further certify that I am the owner of the property where the proposed project is located or that I have a legal interest in the property and that I have full legal authority to seek this permit.

U.S.C. Section 1001 provides that: Whoever, in any manner within the jurisdiction of any department or agency of the United States knowingly and willingly falsifies, conceals, or covers up by any trick, scheme or device a material fact or makes any false, fictitious or fraudulent statements or representations or makes or uses any false writing or document knowing same to contain any false, fictitious or fraudulent statement or entry, shall be fined not more than \$10,000 or imprisoned not more than five years, or both.

**Mississippi Coastal Program (Coastal area only)**

I certify that the proposed project for which authorization is sought complies with the approved Mississippi Coastal Program and will be conducted in a manner consistent with the program.

  
\_\_\_\_\_  
Signature of Applicant or Agent

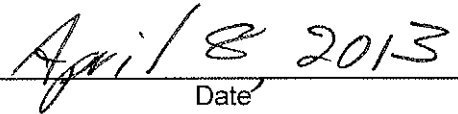
  
\_\_\_\_\_  
Date



---

**15. Fees**

Payable to MS Dept. of Marine Resources  
\$50.00 Single-family residential application fee  
\$500.00 Commercial application fee  
Public notice fee may be required

Please include appropriate fees for all projects proposed in coastal areas of Hancock, Harrison and Jackson Counties.

---

**16. If project is in Hancock, Harrison or Jackson Counties, send one completed copy of this application form and appropriate fees listed in Item 15 to:**

Department of Marine Resources  
Bureau of Wetlands Permitting  
1141 Bayview Avenue  
Biloxi, MS 39530  
(228) 374-5000

**If project IS NOT in Hancock, Harrison or Jackson Counties, send one completed copy of this application form to each agency listed below:**

District Engineer  
Mobile District  
Attn: CESAM-RD  
P.O. Box 2288  
Mobile, AL 36628-0001

District Engineer  
Vicksburg District  
Regulatory Branch  
Attn: CEMVK-OD-F  
4155 Clay Street  
Vicksburg, MS 39183-3435

Director  
Mississippi Dept. of Environmental Quality  
Office of Pollution Control  
P.O. Box 10385  
Jackson, MS 39289

---

**17. In addition to the completed application form, the following attachments are required:*****Attachment "A" Drawings***

Provide a vicinity map showing the location of the proposed site along with a written description of how to reach the site from major highways or landmarks. Provide accurate drawings of the project site with proposed activities shown in detail. All drawings must be to scale or with dimensions noted on drawings and must show a plan view and cross section or elevation. Use 8 1/2 x 11" white paper or drawing sheet attached.

***Attachment "B" Authorized Agent***

If applicant desires to have an agent or consultant act in his behalf for permit coordination, a signed authorization designating said agent must be provided with the application forms. The authorized agent named may sign the application forms and the consistency statement.

***Attachment "C" Environmental Assessment (Coastal Area Only)***

Provide an appropriate report or statement assessing environmental impacts of the proposed activity and the final project dependent on it. The project's effects on the wetlands and the effects on the life dependent on them should be addressed. Also provide a complete description of any measures to be taken to reduce detrimental offsite effects to the coastal wetlands during and after the proposed activity. Alternative analysis, minimization and mitigation information may be required to complete project evaluation.

***Attachment "D" Variance or Revisions to Mississippi Coastal Program (Coastal area only)***

If the applicant is requesting a variance to the guidelines in Section 2, Part III or a revision to the Coastal Wetlands Use Plan in Section 2, Part IV of the Rules, Regulations, Guidelines and Procedures of the Mississippi Coastal Program, a request and justification must be provided.

## Addendum to:

### Department of the Army Permit Application SAM-2009-1768-DMY

#### Introduction

This addendum revises information contained in the original Gulfport Expansion permit application filed with the U.S. Army Corps of Engineer (USACE), Mobile District on March 17, 2010. Ongoing planning for port development, efforts supporting the permitting process and the preparation of an Environmental Impact Statement have led to changes in the original conceptual plan for Port expansion and identified a need in the future to deepen the Federal Navigation Channel (FNC).

The goal of the Mississippi State Port Authority (MSPA) is to build a maximum efficiency port facility capable of handling a container traffic volume of 2 million TEUs per year. This could be accomplished within a reasonable time frame with the proposed expansion area features and a deeper FNC. As such there is a need to revise the original permit application to include the proposed maximum efficiency expansion project. Details of the maximum efficiency conceptual plan and cross sections of the deeper FNC are shown in the revised Attachment A Drawings.

The permit application and Sections 5, 6, 9, 10, 11.2, 11.3, and 11.4 of Attachment - Additional Information in the original permit application have been revised as appropriate. Revisions to sections are noted as follows: deleted items are shown as strikethrough and additions are shown as highlighted text. Other portions of the original permit application information remain unchanged and are therefore not included in this addendum.

Revisions to original permit application "Attachment A" drawings include the following:

Figure 3	Proposed Plan	New Figure
Figure 4	Typical Wharf and Fill Cross Section	Revised new Grade line
Figure 5	North Harbor Cut Typical Cross Section	Deleted and Replaced with Channel Typical Section
Figure 6	ODMDS and Littoral Zone Disposal Areas	Revised to add Pascagoula ODMDS
Figure 7	Typical Breakwater Section	Revised length of Breakwater
Figure 8	Potential Beneficial Use Sites	New Figure

**ATTACHMENT – ADDITIONAL INFORMATION (REVISED April 2013)**

**5. Additional information relating to the dredging**

<b>Channels</b>	<b>Length</b>	<b>Width</b>	<b>Existing Depth</b>	<b>Proposed Depth</b>
Turning Basin	1,300'	0' to 390'	-7'	-36'
Berthing Area	8,010'	1,510' to 1,890'	-7' to -36'	-36'
North Harbor Cut	2,850'	80'	-32' to +10'	-8'

<b>Channels</b>	<b>Length</b>	<b>Width</b>	<b>Existing Depth</b>	<b>Proposed Navigation Depth</b>
Existing Turning Basin	2640'	1120'	-32' to -36'	-47'
Turning Basin Expansion	3200'	1500'	-7'	-47'
Berthing Area	3600'	130'	-7' to -36'	-47'
Sound Channel	12 miles	300'	-36'	-47'
Entrance Channel	8 miles	400'	-38'	-49'

Note: Modification to the existing FNC includes deepening and possibly widening the channel. The need to widen the channel will be based on the results of ship simulations. Two feet of advanced maintenance and two feet of allowable over depth will be added to the navigation depths as standard requirements. Also, the proposed North Harbor Cut is no longer a project feature.

**6. Additional information relating to the proposed activity**

The proposed project will incorporate the existing MSPA facilities into the proposed expansion project. It will also include the 84-acre fill area authorized under Department of the Army Permit MS96-02828-U. The entire 84 acre fill is currently under construction as part of the Port of Gulfport Restoration Program. Sixty (60) acres of the 84-acre fill area are currently under construction and should be completed November 2010. Filling of the remaining 24 acres will start after the permit conditions and other environmental requirements have been satisfied. The expected start date for filling the remaining 24 acres is November 2010. The proposed expansion project would require modification of the existing federally authorized Gulfport Harbor Navigation project, specifically the Turning Basin.

Sediment transport, current and water quality studies will be conducted during the permitting process to evaluate impacts of the proposed project. The need for additional water quality and fish passage channels will be considered during design of the project. The North Harbor Cut is no longer a project feature.

The height of the bridge over the proposed North Harbor Cut will be determined as project design advances during the permitting process.



**9. Describe the purpose of this project. Describe the relationship between this project and any secondary or future development the project is designed to support.**

~~Deepening and widening of the Gulfport Harbor Federal Navigation Channel is not required to support the proposed project but would likely be required before any future long-term development of the Port.~~

The proposed project will include modifications to the authorized FNC and other navigation features necessary for efficient port operations. These modifications will include the navigation channel from the Gulf to the port facilities to support a navigable channel depth of 47 feet in the Mississippi Sound and 49 feet in the Bar Channel plus advance maintenance and allowable over depth requirements. Modification to navigation features adjacent to the port facilities include deepening the existing Federal turning basin area and port berthing areas, a turning basin expansion, and new berthing areas. The depth of these features will be appropriate to the deeper navigation channel. Widening the channel may be requested based on results of planned ship simulations. Final Channel design and associated environmental impacts will be addressed during the permitting and Environmental Impact Statement process.

**10. Describe the public benefits of the proposed activity and of the projects dependent on the proposed activity. Also describe the extent of public use of the proposed project.**

The proposed project will provide local, state and national economic benefits as well as providing jobs for low-to-moderate-income individuals. ~~The proposed North Harbor Cut will provide the public with small craft access up and down the near shore coast of the Mississippi Sound without having to navigate south and around the Port, crossing the navigation channel.~~ The North harbor Cut is no longer a part of the Conceptual Plan. Access to the Yacht Basin on the northeast side of the proposed project will be maintained.

**11. Narrative Project Description**

**11.2 Dredging**

The proposed project would require dredging to deepen and possibly widen the Federal navigation project including the Gulf Entrance and Bar Channels, the Mississippi Sound Channel. The existing Turning Basin would be deepened. Estimated volumes would be calculated based on the results of ship simulations. ~~dredging for a portion of the new turning basin, for access to the new berths, and the North Harbor Cut (navigation/circulation/water quality/fish passage channel).~~

Dredging will also be required for the Turning Basin Expansion and West Pier Expansion Berths. Estimated dredging quantities for all of these features are shown in the following table.

**DREDGING QUANTITIES**

Dredging location	Estimated Dredging Volume (CY)
Federal Channel	33,000,000
Federal Turning Basin	2,200,000
West Pier Expansion Berths	900,000
Turning Basin Expansion	5,800,000
Total Volume	41,900,000



Dredging activities also include the potential removal and disposal of soft sediments from the proposed West Pier and East Pier Terminal Expansion footprints for geotechnical stability. It is currently estimated that the West Pier Terminal Expansion will require removal of 2.3 million cubic yards (CY) of material and the East Pier Terminal Expansion will require removal of 555,000 CY of material. Final determination of these dredging quantities will be based upon additional geotechnical data analysis during the permitting and design process.

Maintenance dredging would be required for the proposed Turning Basin Expansion and new berthing areas. Estimated maintenance dredging volumes would vary from 245,000 to 535,000 CY per year for the Turning Basin and 50,000 to 505,000 CY per year for berthing areas. The range for both the dredging frequency and yearly volumes would be affected by seasonal, subtropical, and tropical storm events that could significantly impact these areas. It is assumed that regular maintenance of the FNC would be carried out by USACE.

~~Dredging for the portion of the new Turning Basin located outside the authorized Federal project will require dredging approximately 160,000 CY. The~~ Dredged material that is structurally suitable and meets project needs will be used for fill on the project site. Other ~~any~~ material ~~that is not structurally suitable~~ would be evaluated for potential beneficial use. Possible beneficial use sites include the Littoral Zone Disposal area southeast of Cat Island (Attachment A figure 6) for suitable sandy material and State of Mississippi potential beneficial use sites for other types of material (Attachment A Figure 8). Material that is not suitable for beneficial use will be disposed of in an approved ODMDS. Possible ODMDS sites include the Gulfport (West) ODMDS and the Pascagoula ODMDS as shown in Attachment A figure 6. Also, thin-layer disposal areas adjacent to the channel in the Mississippi Sound (Attachment A Figure 6) are viable options for future maintenance dredging requirements. ~~Material that is suitable for beneficial use will be placed in the Littoral Zone Disposal Area southeast of Cat Island or in another approved area.~~

~~Dredging for access to the new berths will require dredging approximately 16,200,000 CY. Dredged material that is structurally suitable will be used for fill on the project site. Any material that is not structurally suitable will be evaluated for potential beneficial use. Material that is not suitable for beneficial use will be disposed of in an approved ODMDS. Material that is suitable for beneficial use will be placed in the Littoral Zone Disposal Area southeast of Cat Island or in another approved area.~~

~~Dredging for access to the North Harbor Cut will require excavation and dredging approximately 1,900,000 CY. Most of the material is structurally suitable and will be used for fill on the project site. Any material that is not structurally suitable will be evaluated for potential beneficial use. Material that is not suitable for beneficial use will be disposed of in an approved ODMDS. Material that is suitable for beneficial use will be placed in the Littoral Zone Disposal Area southeast of Cat Island or in another approved area.~~



### 11.3 Construction of Structures

The proposed project would require construction of wharves/pier, bulkheads and breakwater structures. Approximately 3,500 ~~12,660~~ linear feet of marginal wharf (pier structure) will be constructed around the proposed Turning Basin and along the eastern edge of the west fill area. The wharf/pier is proposed to be constructed of a steel sheet pile wall along the breasting line (front face of the wharf) and filled behind with soil with an asphalt paved surface. The wharf will be approximately 130 feet wide and constructed at elevation +9.5 feet North American Vertical Datum (NAVD 1988). Directly behind the 130 feet wide wharf, a retaining wall structure will be constructed to allow the backland areas to be constructed at approximately elevation +25 feet NAVD 88 (Attachment A Figure 4).

Approximately ~~7,590~~ 4,000 linear feet of rip-rap breakwater will be constructed along the east side of the ship channel to provide wave protection for the proposed project. The breakwater will vary from 98 to 102 feet wide at its base with a top width of 10 feet and a top elevation of +10 feet NAVD 88 (Attachment A Figure 7). Hydrodynamic models and ship simulations will be used to determine the need for and the final dimensions of the breakwater, if it is required.

### 11.4. Filling

The proposed Port Expansion Project will require filling approximately ~~681~~ 200 acres of water bottoms. This includes approximately 160 acres for the West Pier Terminal Expansion, 15 acres for the East Pier Terminal Expansion, 9 acres for the North Harbor Fill Area, and 18 acres for the Eastern Breakwater. ~~for the restoration and revitalization of the Port.~~ Approximately 13,200,000 ~~38,400,000~~ CY of predominately sandy fill material will be required. The fill material will come from commercial borrow pits and/or through the use of dredged material from channel dredging projects, excess excavated material from road construction projects, and other approved sources.

Armor protection will be provided on the exposed faces of the proposed fill that are not protected by a bulkhead.

Breakwater construction will require placing approximately 250,000 ~~CY224,000~~ of rip-rap on approximately ~~17.4~~ 18 acres of water bottoms.



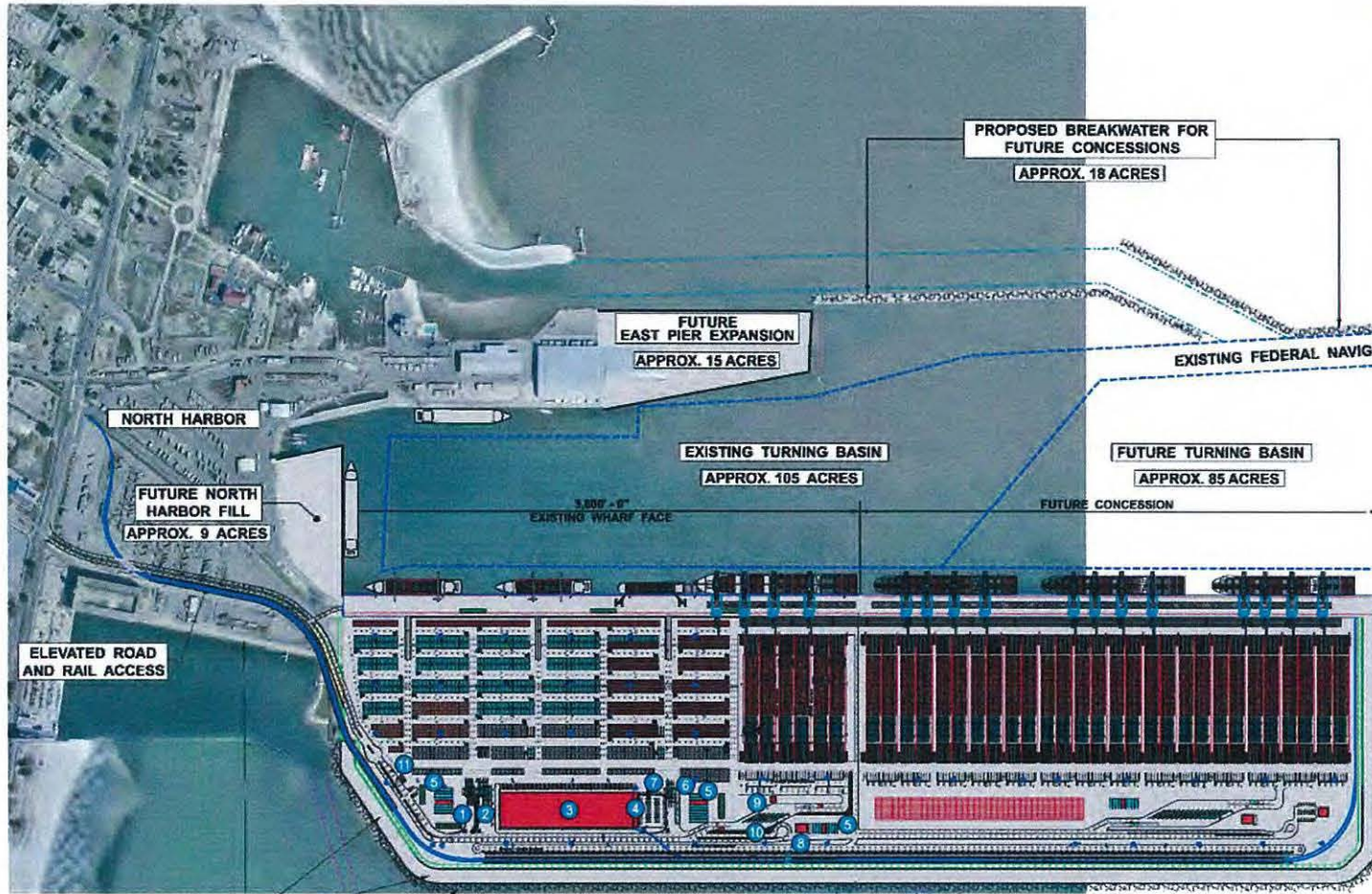

- DESCRIPTION**
- 1 EXIST. TENANT GATE (4 LANES)
  - 2 EXIST. TENANT GATE (6 LANES)
  - 3 TRANSIT SHED
  - 4 OFFICE BUILDING (TWO STORY)
  - 5 MAINTENANCE FACILITY
  - 6 EXIST. TENANT GATE (4 LANES)
  - 7 EMPLOYEE PARKING (106 SLOTS)
  - 8 RTG SHOP
  - 9 GATE BUILDING
  - 10 INCLINED GATE (10 LANES) - NEW TENANT
  - 11 MAIN SUBSTATION

- LEGEND**
- BUILDING
  - CANOPY
  - SUBSTATION
  - TRAILER
  - GUARD BOOTH
  - ELEVATED RAIL
  - RAIL
  - ROADWAY
  - ELEVATED ROADWAY
  - SMALL CRAFT CHANNEL
  - EXISTING BASIN AND CHANNEL
  - EXISTING COMMERCIAL SMALL CRAFT CHANNEL
  - SLOPE

**ALTERNATIVE 2 - MAXIMUM EFFICIENCY**

<table border="1" style="width: 100%; border-collapse: collapse;"> <tr> <td style="width: 50%; text-align: center;">REVISION TO LAYOUT</td> <td style="width: 50%; text-align: center;">CK</td> <td style="width: 50%; text-align: center;">LEO</td> <td style="width: 50%; text-align: center;">BY</td> <td style="width: 50%; text-align: center;">M. LAZIC</td> </tr> <tr> <td style="text-align: center;">1</td> <td style="text-align: center;">2/22/11</td> <td style="text-align: center;">DATE</td> <td style="text-align: center;">G. KIM</td> <td style="text-align: center;">J. HELSTROM</td> </tr> <tr> <td style="text-align: center;">USOR</td> <td style="text-align: center;">M. LAZIC</td> <td style="text-align: center;">DR</td> <td style="text-align: center;">M. LAZIC</td> <td style="text-align: center;">M. LAZIC</td> </tr> </table>	REVISION TO LAYOUT	CK	LEO	BY	M. LAZIC	1	2/22/11	DATE	G. KIM	J. HELSTROM	USOR	M. LAZIC	DR	M. LAZIC	M. LAZIC	<p style="text-align: center;"><b>CH2MHILL</b></p> <p style="text-align: center;">PORT REDEVELOPMENT PLAN SITE PLAN - ALTERNATIVE 2 - MAXIMUM EFFICIENCY</p> <p style="text-align: center;">VERIFY SCALE DATE: FEBRUARY 2015 PROJ: 401731 DWG: 1 SHEET</p> <p style="text-align: right; font-size: small;">ISSUED FOR PRELIMINARY REVIEW</p>
REVISION TO LAYOUT	CK	LEO	BY	M. LAZIC												
1	2/22/11	DATE	G. KIM	J. HELSTROM												
USOR	M. LAZIC	DR	M. LAZIC	M. LAZIC												

FILE OF DOCUMENTS: THE USER SHALL BE RESPONSIBLE FOR THE USER'S RESULTS OF ANY SOFTWARE APPLICATIONS USED IN THE PREPARATION OF THIS DRAWING. CH2MHILL SHALL NOT BE RESPONSIBLE FOR THE USER'S RESULTS OF ANY SOFTWARE APPLICATIONS USED IN THE PREPARATION OF THIS DRAWING.

FILENAME: Alternative2-Full.dwg PLOT DATE: 4/16/2012 PLOT TIME: 3:59:34 PM



NOT TO SCALE



Note: This map is for presentation use only and not to be used for construction purposes  
**REVISED FIGURE**



**Figure 3  
Proposed Plan**

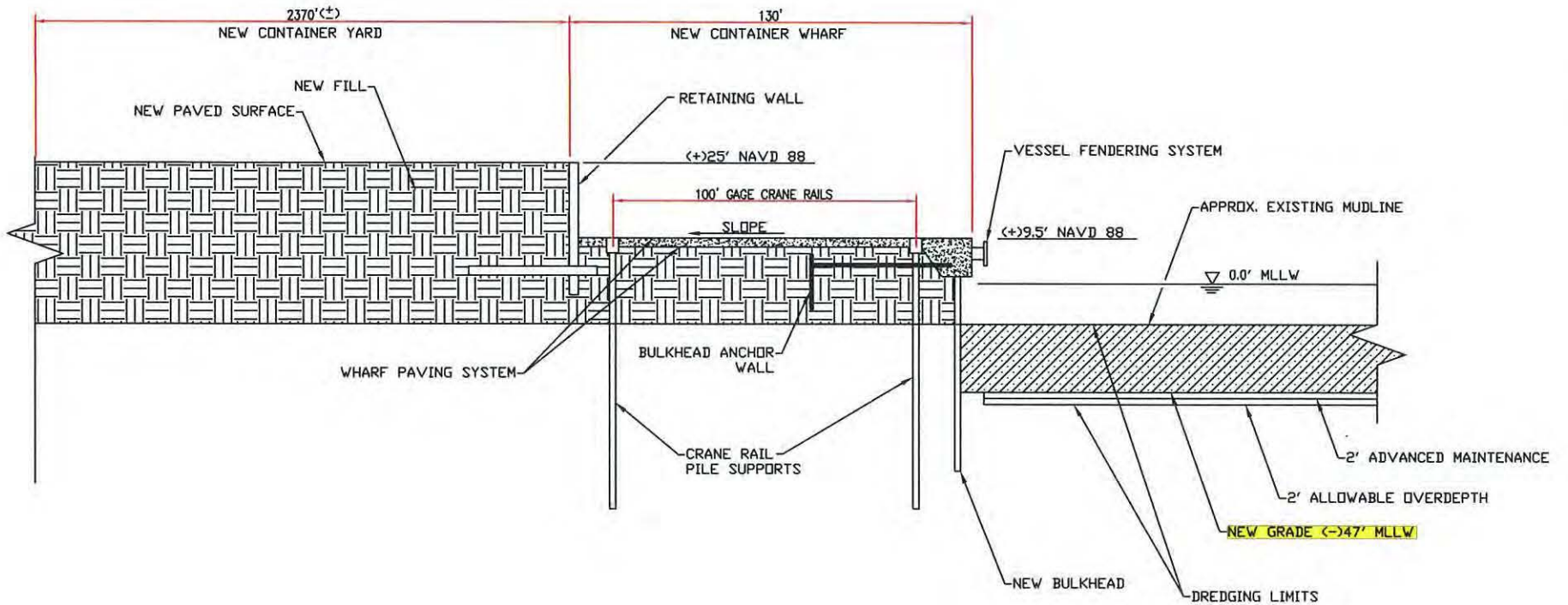



02-05-2013

**LEGEND**

-  2 Ft Allowable Overdepth
-  Existing Required Dredging Prism
-  Proposed Dredging Prism

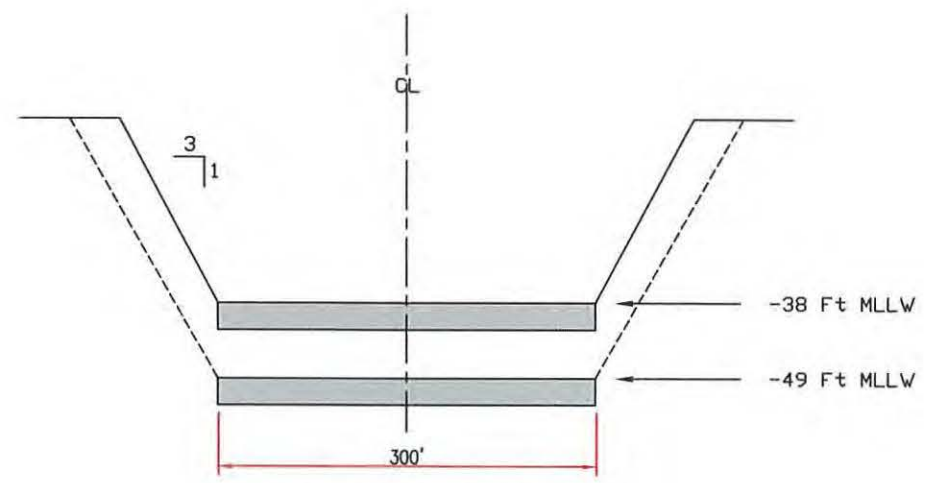

Gulfport Sound Channel Typical Section  
Not To Scale

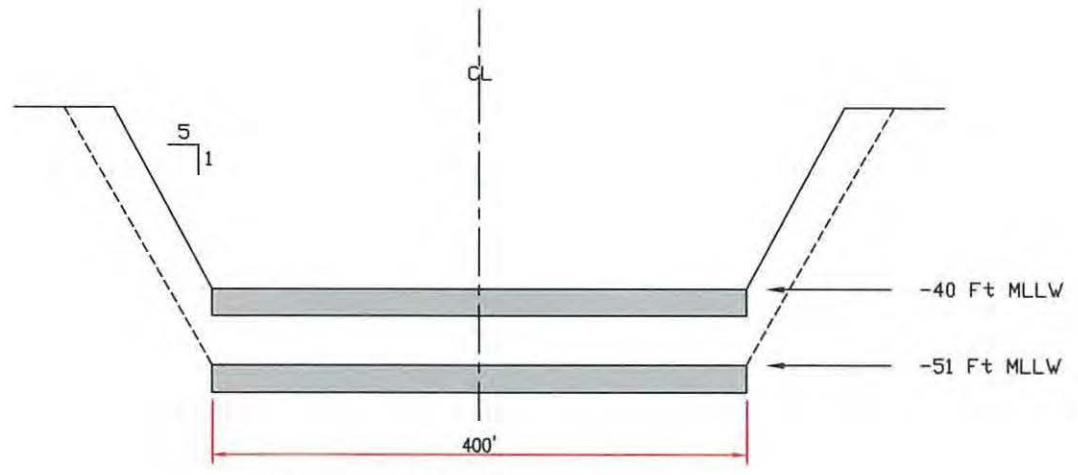

Gulfport Bar Channel Typical Section  
Not To Scale

**NOTE:**

1. Required dredging depth equals the project depth plus two feet of advance maintenance.
2. Channel widths vary from 300 feet in the Gulfport Sound Channel to 400 feet in the Gulfport Bar channel.

02-05-2013



NOT TO SCALE



NEW FIGURE

FIGURE 5  
TYPICAL CHANNEL  
CROSS SECTIONS



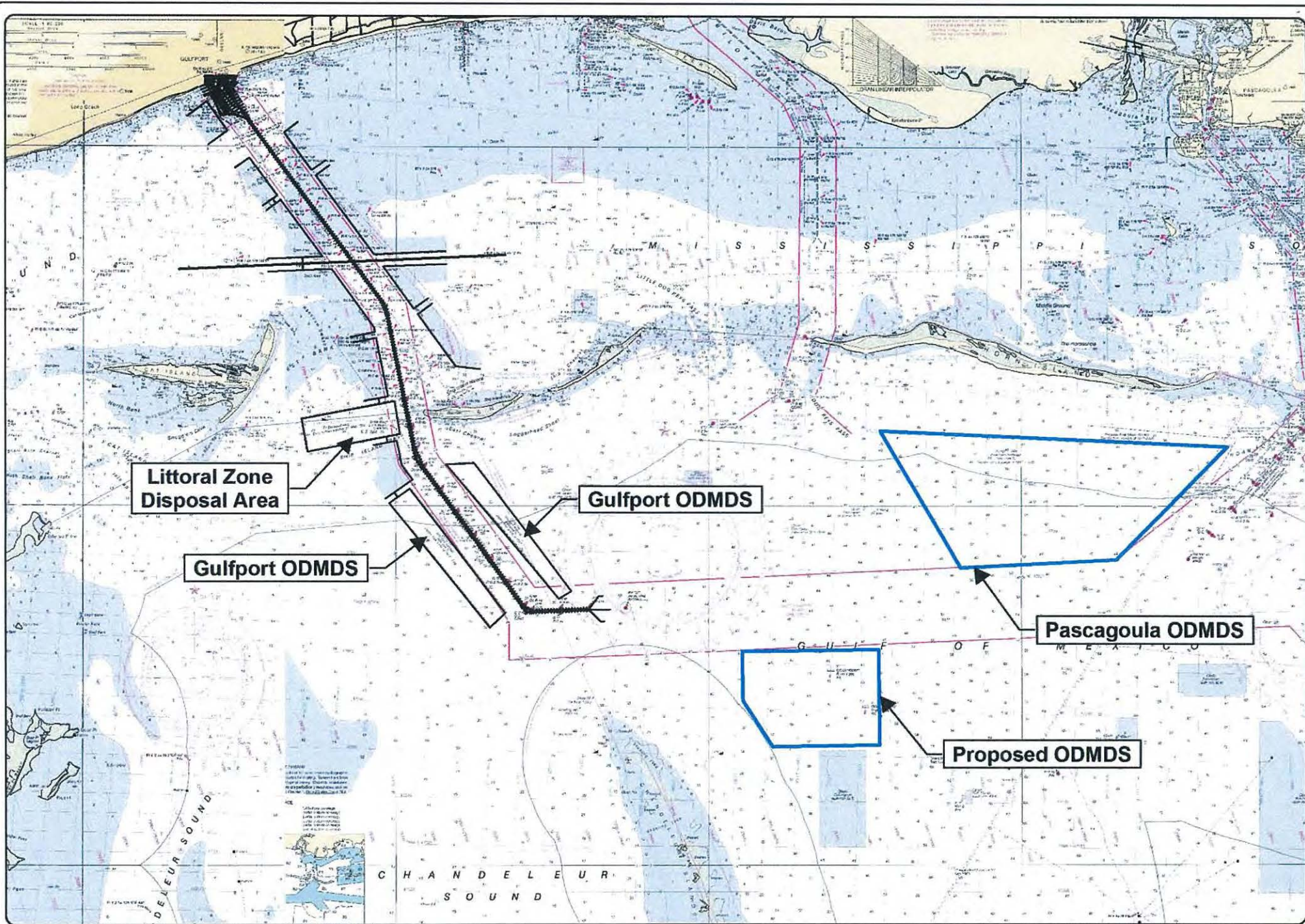

**VOLKERT**

0 2 4 Miles  
1 inch = 4 miles



Note: This map is for presentation use only and not to be used for construction purposes.  
**REVISED FIGURE**

**Figure 6**  
**Ocean Dredge Material Disposal Sites and Littoral Zone Disposal Area**



NOTE:

APPROXIMATELY 4,000 LF OF NEW BREAKWATER REQUIRED.

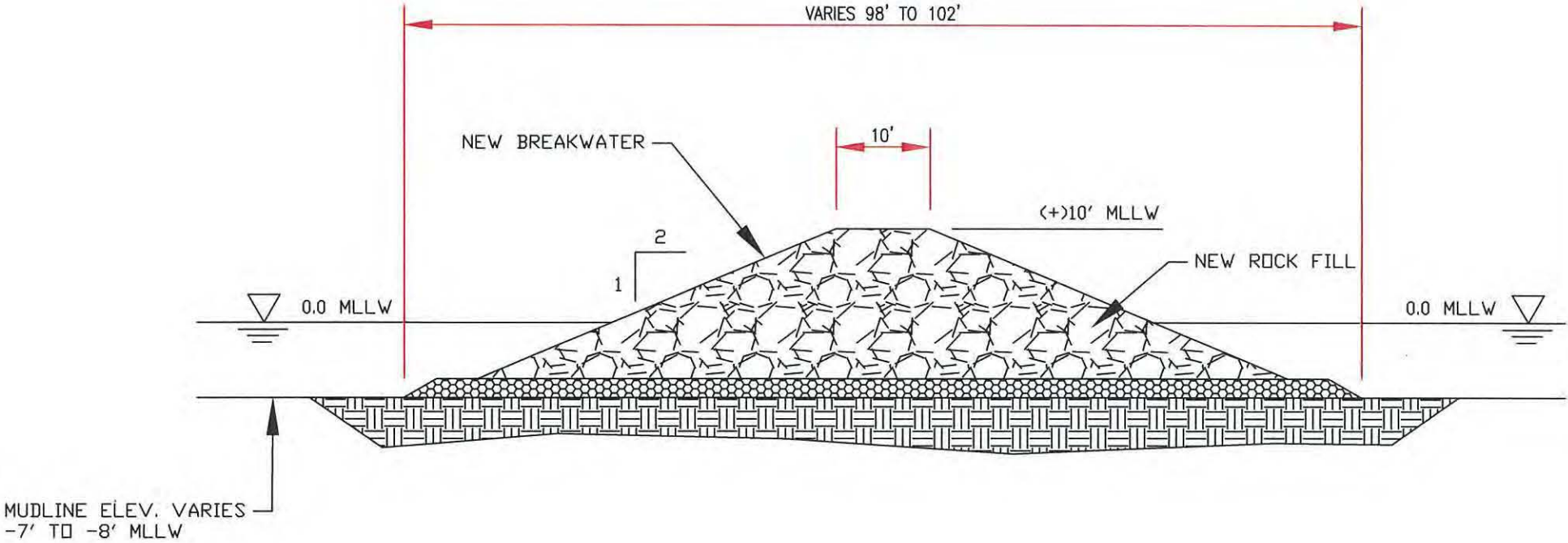

02-05-2013



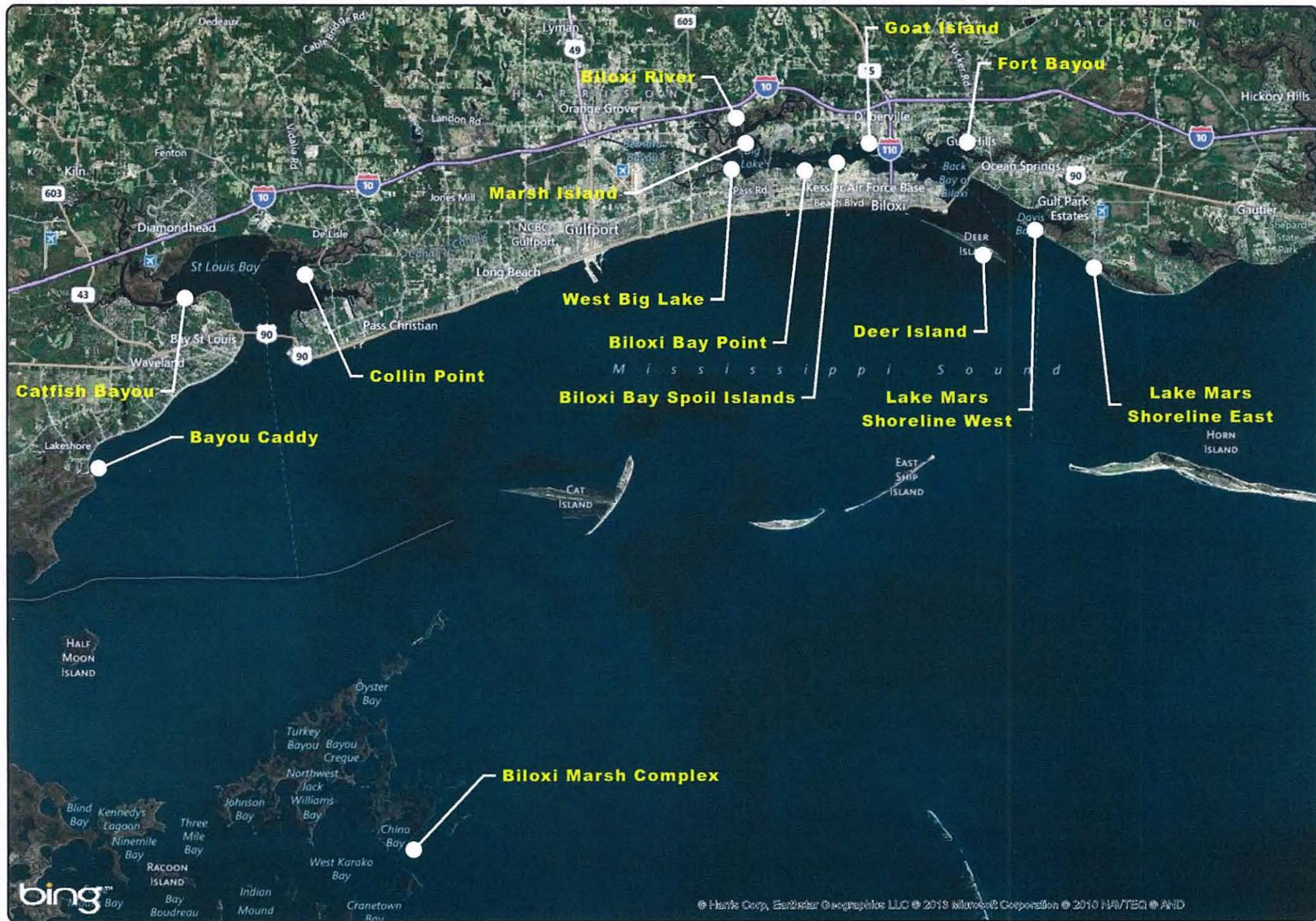

**VOLKERT**

0 2.5 5 Miles  
1 inch = 5 miles



© Harris Corp, Earthstar Geographics LLC © 2013 Microsoft Corporation © 2010 NAVTEQ © AND

Note: This map is for presentation use only and not to be used for construction purposes.  
**NEW FIGURE**

**Figure 8**  
**Potential Beneficial Use Sites**

**Appendix A5**

***Federal Register* Notice of Project Modification  
and Additional Public Scoping, May 9, 2013**





Dated: May 3, 2013.

**Aaron Siegel,**

*Alternate OSD Federal Register Liaison  
Officer, Department of Defense.*

**DELETION:**

**F036 AFPC N**

**SYSTEM NAME:**

Air Force Personnel Test 851, Test Answer Sheets (January 22, 2009, 74 FR 4012).

**REASON:**

This is a duplicate system of records; active records are covered under SORN F036 AFPC K, Enlisted Promotion Testing Record (March 21, 2013, 78 FR 17386). Therefore, SORN F036 AFPC N, Air Force Personnel Test 851, Test Answer Sheets, can be deleted.

[FR Doc. 2013-10983 Filed 5-8-13; 8:45 am]

**BILLING CODE 5001-06-P**

**DEPARTMENT OF DEFENSE**

**Department of the Army, Corps of Engineers**

**Modification of Permit Application and Intent for Additional Public Scoping for an Environmental Impact Statement for the Port of Gulfport Expansion Project, Harrison County, Mississippi (Department of the Army Permit Number SAM-2009-1768-DMY)**

**AGENCY:** U.S. Army Corps of Engineers, DoD.

**ACTION:** Notice of Intent.

**SUMMARY:** The U.S. Army Corps of Engineers, Mobile District (USACE) announces a modification to a project proposed by the Mississippi State Port Authority (MSPA) for which an Environmental Impact Statement (EIS) is being prepared. The Mississippi Development Authority (MDA) and the National Marine Fisheries Service (NMFS) are cooperating agencies in the preparation of the EIS. The proposed port expansion project involves impacting up to 200 acres of open-water bottom in the Mississippi Sound from the construction of wharfs, bulkheads, terminal facilities, container storage areas, intermodal container transfer facilities, dredging and dredged material disposal and infrastructure, and construction of a breakwater of approximately 4,000 linear feet. The recently received permit application modification proposes additional dredging and dredged material placement to modify the Gulfport Harbor Federal Navigation Channel (FNC) for a length of approximately 20 miles from the current federally

authorized dimensions. The federally authorized turning basin would also be modified, as would the proposed turning basin expansion. The proposed project will include modifications to the authorized FNC and other navigation features to support a navigable channel depth of up to 47 feet in the Mississippi Sound and 49 feet in the Bar Channel plus advance maintenance and allowable over depth requirements. Modification to navigation features adjacent to the port facilities include deepening the existing Federal turning basin area and port berthing areas, a turning basin expansion, and new berthing areas. Widening the channel may be requested based on results of planned ship simulations. Final channel design and associated environmental impacts will be addressed during the permitting and EIS process. The EIS will evaluate the effects of construction and long term effects of the proposed expansion and channel modification, including placement of new work and maintenance dredged material in beneficial use sites or other placement areas, such as open water and ocean dredged material disposal sites.

Alternatives to the proposed action will be evaluated in the EIS, which will assist the USACE in deciding whether to issue a Department of the Army permit.

The purpose of this Notice of Intent is to inform and educate the public of changes to the proposed project; invite public participation in the EIS process; announce the plans for an additional public scoping meeting; solicit public comments for consideration in establishing the scope and content of the EIS; and provide notice of potential impacts to open-water benthic and other habitats potentially impacted by the project.

**DATES:** A scoping meeting will be held on May 21, 2013. Comments will be accepted in written format at the scoping meeting or via mail/email until June 17, 2013. To ensure consideration, comments should be post-marked by this date. Late comments will be considered to the extent practicable.

**ADDRESSES:** The scoping meeting will be held at the Courtyard Marriott Gulfport Beachfront Hotel, 1600 East Beach Boulevard, Gulfport, MS. Written comments regarding the proposed EIS scope or permit application modifications should be addressed to Mr. Damon M. Young, P.G. USACE, Mobile District, Post Office Box 2288, Mobile, Alabama 36628. Individuals who would like to electronically provide comments should contact Mr. Young by electronic mail: [port.gulfporteis@usace.army.mil](mailto:port.gulfporteis@usace.army.mil).

**FOR FURTHER INFORMATION CONTACT:** For information about this project, to be included on the mailing list for future updates and meeting announcements, or to receive a copy of the DRAFT EIS when it is issued, contact Damon M. Young, P.G., at the USACE at (251) 694-3781 or the address provided above. Mr. Ewing Milam, at the MDA can also be contacted for additional information at P.O. Box 849, Jackson, Mississippi 39205-0849, telephone (601)-359-2157 or by electronic mail at [emilam@mississippi.org](mailto:emilam@mississippi.org).

**SUPPLEMENTARY INFORMATION:**

1. *Background:* The Gulfport Harbor Navigation Project was adopted by the Rivers and Harbors Act approved on July 3, 1930 (House Document Number 692, 69th Congress, 2nd session) and the Rivers and Harbors Act approved on June 30, 1948 (House Document Number 112, 81st Congress, 1st session). Construction of the existing Gulfport Harbor commenced in 1932 and was completed in 1950. The FNC is approximately 20 miles in length, including 11 miles of channel in the Mississippi Sound (Sound Channel), 2 miles of Bar Channel, and 7 miles of channel in the Gulf of Mexico (Gulf Channel). Authorization to conduct improvements to the harbor was issued in the Fiscal Year 1985 Supplemental Appropriations Act (Pub. L. 99-88). The Water Resources Development Acts (WRDAs) 1986 and 1988 further modified the previous authorization to cover widening and deepening and thin-layer disposal, respectively. The authorized deepening was completed in 1993. In 2012 the channel was widened to the federally authorized dimensions. The navigation channel is currently federally authorized at 36 feet deep and 300 feet wide in the Sound Channel and 38 feet deep and 400 feet wide in the Bar and Gulf Channels. The Port's North Harbor (Inner Harbor) is authorized at a depth of 32 feet and the South Harbor (Outer Harbor) and Gulfport Turning Basin are authorized at a depth of 36 feet. A Department of the Army Permit MS96-02828-U was issued in 1998 authorizing an 84-acre expansion to fill the West Pier to construct new tenant terminals and infrastructure. Phases I and II of that project are complete and Phase III is currently under construction.

2. *Location:* The proposed Port of Gulfport Expansion Project is located in the City of Gulfport, Harrison County, Mississippi. The proposed project is approximately 80 miles west of Mobile, Alabama, and 80 miles east of New Orleans, Louisiana. The Port encompasses approximately 184 acres

and is located within 5 miles of the Gulf Intracoastal Waterway (GIWW) and approximately 7 miles south of Interstate Highway 10. The FNC runs from the Port, between Cat and West Ship islands (in Ship Island Pass) into the Gulf of Mexico and is approximately 20 miles long.

3. *Work:* The proposed project involves filling of up to 200 acres of open-water bottom in the Mississippi Sound, the construction of wharfs, bulkheads, terminal facilities, container storage areas, intermodal container transfer facilities, expansion of the existing turning basin, dredging and dredged material disposal and infrastructure, and construction of a breakwater of approximately 4,000 linear feet. The proposed expanded port facility will be elevated 25 feet above sea level to provide protection against future tropical storm surge events. The permit application modification for the proposed project includes deepening and possible widening of the existing FNC from the federally authorized dimensions. The federally authorized turning basin would also be modified, as would the proposed adjacent turning basin expansion. A Department of the Army permit is required for the proposed project, pursuant to Section 404 of the Clean Water Act (33 U.S.C. 1251), Section 10 of the Rivers and Harbors Act (33 U.S.C. 403), and Section 103 of the Marine Protection, Research, and Sanctuaries Act (33 U.S.C. 1401–1445, 16 U.S.C. 1431 et seq., also 33 U.S.C. 1271).

An EIS is being prepared pursuant to the National Environmental Policy Act (NEPA) of 1969, as amended (42 U.S.C. 4321 et seq.), and the Council on Environmental Quality NEPA regulations (40 CFR Parts 1500–1508) to assess the potential environmental impacts associated with the construction, operation, and maintenance of the proposed project as submitted and modified by the MSPA.

4. *Need:* According to the MSPA, this project will contribute to the long-term economic development of Mississippi and the Gulf Coast region by expanding the Port footprint and facilities to increase cargo throughput, provide additional employment opportunities, and to increase the economic benefits produced by the Port. This project is needed to expand the Port's current footprint, thus providing an opportunity to increase the Port's capacity for moving cargo and growing. Specific alternatives are being developed as part of the EIS process and feedback provided during the additional scoping meeting will be taken into consideration.

5. *Affected Environment:* Environmental characteristics that may be affected by the proposed project include geological, chemical, biological, physical, socioeconomic, and commercial and recreational activities. Offshore, the navigation channel extends 20 miles south into the Gulf of Mexico, passing close to the western end of Ship Island. On-shore, the regional environment is characterized as Coastal Lowlands, and the shore area, where not developed, consists typically of gently undulating swampy plains. The beach area is man-made and bordered by constructed seawalls. The existing Port, as part of the man-made environment of Gulfport, is constructed on fill material. The Gulfport area is well developed. Beyond the seawalls are extensive commercial and residential developments. The nearshore and offshore area is known for its valuable resources as a productive fishery and is also utilized extensively for commercial and recreational shipping and boating.

6. *Applicable Environmental Laws and Policies:* The proposed project could result in both beneficial and negative environmental impacts. These impacts will be evaluated in the EIS in accordance with applicable environmental laws and policies, which include NEPA; WRDA; Endangered Species Act; Clean Water Act; Clean Air Act; U.S. Fish and Wildlife Coordination Act; National Historic Preservation Act; Coastal Barrier Resources Act; Magnuson–Stevens Fishery Conservation and Management Act; Coastal Zone Management Act; Marine, Protection, Research, and Sanctuaries Act; Rivers and Harbors Act; National Marine Sanctuaries Act; Fishery Conservation Act; Marine Mammal Protection Act; Executive Order 12898, Environmental Justice in Minority Populations and Low-Income Populations; Executive Order 13045, Protection of Children from Environmental Health Risks and Safety Risk (among other Executive Orders); and Ports and Waterways Safety Act.

7. *Preliminary Identification of Environmental Issues:* The following list of environmental issues has been tentatively identified for analysis in the EIS. This list was developed during preliminary internal scoping, through previous public scoping efforts, and from information from similar projects, and is neither intended to be all inclusive nor a predetermined set of potential impacts. It is presented to facilitate public comment on the planned scope of the EIS. Additions to or deletions may occur as a result of the public scoping process. Preliminary identified environmental issues include

but are not limited to the loss of aquatic resources (impact to potential submerged and shoreline aquatic habitat); water quality; salinity and flows; sediment transport and currents; threatened and endangered species (including critical habitat and essential fish and shellfish habitat); air quality; traffic; socioeconomics; and impacts to low income and minority populations. The evaluation will consider alternatives, secondary and cumulative impacts, and mitigation.

8. *Scoping meeting:* A public scoping meeting was held in spring of 2011 in Gulfport, Mississippi to solicit comments from the public and agencies in regards to the original permit application and proposed project. To ensure that all of the issues related to this proposed project and permit action modification are addressed, the USACE will conduct an additional public scoping meeting in which agencies, organizations, and members of the general public are invited to present comments or suggestions with regard to the range of actions, alternatives, and potential impacts to be considered in the EIS, given the proposed project changes. The scoping meeting will be held at the Courtyard Marriott Gulfport Beachfront Hotel, 1600 East Beach Boulevard, Gulfport, MS, on May 21, 2013. The scoping meeting will begin with an informal open house from 5:30 p.m. to 6:30 p.m. followed by a formal presentation of the proposed permit action and modifications. Comments will be accepted following the formal presentation until 8:00 p.m. Displays and other forms of information about the proposed action and modifications will be available, and the USACE, the MSPA and the MDA personnel will be present at the informal session to discuss the proposed project and modifications and the EIS Process. The USACE invites comments on the proposed scope and content of the EIS from all interested parties. Verbal or written comments will be taken at the scoping meeting following the formal presentation until 8:00 p.m. A time limit will be imposed on verbal comments, as necessary. If hearing impaired or language translation services are needed, please contact Damon M. Young, P.G., at the USACE at (251) 694–3781, at [port.gulfporteis@usace.army.mil](mailto:port.gulfporteis@usace.army.mil), or at the street address provided above.

9. *Draft EIS:* It is anticipated that a Draft EIS will be made available for public review in early calendar year 2014. A public hearing will be held during the public comment period for the Draft EIS.



Approved By:  
**Craig J. Litteken,**  
 Chief, Regulatory Division.  
 [FR Doc. 2013-11038 Filed 5-8-13; 8:45 am]  
 BILLING CODE 3720-58-P

## DEPARTMENT OF DEFENSE

### Department of the Navy

[Docket ID: USN-2013-0013]

#### Privacy Act of 1974; System of Records

**AGENCY:** Department of the Navy, DoD.

**ACTION:** Notice to delete a System of Records.

**SUMMARY:** The Department of the Navy is deleting a system of records notice in its existing inventory of record systems subject to the Privacy Act of 1974 (5 U.S.C. 552a), as amended.

**DATES:** This proposed action will be effective on June 10, 2013 unless comments are received which result in a contrary determination. Comments will be accepted on or before June 10, 2013.

**ADDRESSES:** You may submit comments, identified by docket number and title, by any of the following methods:

\* *Federal Rulemaking Portal:* <http://www.regulations.gov>.

Follow the instructions for submitting comments.

\* *Mail:* Federal Docket Management System Office, 4800 Mark Center Drive, East Tower, 2nd Floor, Suite 02G09, Alexandria, VA 22350-3100.

*Instructions:* All submissions received must include the agency name and docket number for this **Federal Register** document. The general policy for comments and other submissions from members of the public is to make these submissions available for public viewing on the Internet at <http://www.regulations.gov> as they are received without change, including any personal identifiers or contact information.

**FOR FURTHER INFORMATION CONTACT:** Ms. Robin Patterson, HEAD, FOIA/Privacy Act Policy Branch, Department of the Navy, 2000 Navy Pentagon, Washington, DC 20350-2000, or by phone at (202) 685-6545.

**SUPPLEMENTARY INFORMATION:** The Department of the Navy's systems of records notices subject to the Privacy Act of 1974 (5 U.S.C. 552a), as amended, have been published in the **Federal Register** and are available from the address in **FOR FURTHER INFORMATION CONTACT**. The proposed deletion is not within the purview of subsection (r) of

the Privacy Act of 1974 (5 U.S.C. 552a), as amended, which requires the submission of a new or altered system report.

Dated: May 2, 2013.

**Aaron Siegel,**  
 Alternate OSD Federal Register Liaison  
 Officer, Department of Defense.

#### DELETION:

##### N05100-3

Safety Equipment Needs, Issues, Authorizations (May 9, 2003, 68 FR 24959).

#### REASON:

Records are covered under NM05100-5, Enterprise Safety Applications Management Systems (ESAMS) (March 25, 2011, 76 FR 16739); therefore, N05100-3, Safety Equipment Needs, Issues, Authorizations can be deleted.

[FR Doc. 2013-10984 Filed 5-8-13; 8:45 am]

BILLING CODE 5001-06-P

## DEPARTMENT OF EDUCATION

### Applications for New Awards; National Institute on Disability and Rehabilitation Research—Traumatic Brain Injury Model Systems Centers Collaborative Research Project

**AGENCY:** Office of Special Education and Rehabilitative Services, Department of Education.

**ACTION:** Notice.

#### Overview Information

National Institute on Disability and Rehabilitation Research (NIDRR)—Disability and Rehabilitation Research Projects and Centers Program—Disability and Rehabilitation Research Projects—Traumatic Brain Injury Model Systems Centers Collaborative Research Projects; Notice inviting applications for new awards for fiscal year (FY) 2013.

Catalog of Federal Domestic Assistance (CFDA) Number: 84.133A-7.

#### DATES:

*Applications Available:* May 9, 2013.  
*Date of Pre-Application Meeting:* May 30, 2013.

*Deadline for Transmittal of Applications:* July 8, 2013.

#### Full Text of Announcement

##### I. Funding Opportunity Description

*Purpose of Program:* The purpose of the Disability and Rehabilitation Research Projects and Centers Program is to plan and conduct research, demonstration projects, training, and related activities, including

international activities, to develop methods, procedures, and rehabilitation technology that maximize the full inclusion and integration into society, employment, independent living, family support, and economic and social self-sufficiency of individuals with disabilities, especially individuals with the most severe disabilities, and to improve the effectiveness of services authorized under the Rehabilitation Act of 1973, as amended (Rehabilitation Act).

#### *Disability and Rehabilitation Research Projects (DRRPs)*

The purpose of NIDRR's DRRPs, which are funded through the Disability and Rehabilitation Research Projects and Centers Program, is to improve the effectiveness of services authorized under the Rehabilitation Act by developing methods, procedures, and rehabilitation technologies that advance a wide range of independent living and employment outcomes for individuals with disabilities, especially individuals with the most severe disabilities. DRRPs carry out one or more of the following types of activities, as specified and defined in 34 CFR 350.13 through 350.19: Research, training, demonstration, development, utilization, dissemination, and technical assistance.

An applicant for assistance under this program must demonstrate in its application how it will address, in whole or in part, the needs of individuals with disabilities from minority backgrounds (34 CFR 350.40(a)). The approaches an applicant may take to meet this requirement are found in 34 CFR 350.40(b). Additional information on the DRRP program can be found at: [www.ed.gov/rschstat/research/pubs/res-program.html#DRRP](http://www.ed.gov/rschstat/research/pubs/res-program.html#DRRP).

*Priorities:* This notice contains two absolute priorities for this competition. Priority 1, the *DRRP Priority for the Traumatic Brain Injury Model Systems Centers Collaborative Research Projects* is from the notice of final priority for this program, published elsewhere in this issue of the **Federal Register**. Priority 2, the *General DRRP Requirements* priority, which applies to DRRP competitions, is from the notice of final priorities for the Disability and Rehabilitation Research Projects and Centers Program, published in the **Federal Register** on April 28, 2006 (71 FR 25472).

*Absolute Priorities:* For FY 2013 and any subsequent year in which we make awards from the list of unfunded applicants from this competition, these priorities are absolute priorities. Under



## **Appendix A6**

### **Letter from U.S. Army Corps of Engineers to MS State Port Authority**





REPLY TO  
ATTENTION OF

**DEPARTMENT OF THE ARMY**  
MOBILE DISTRICT, CORPS OF ENGINEERS  
P.O. BOX 2288  
MOBILE, AL 36628-0001

February 2, 2015

South Mississippi Branch  
Regulatory Division

**SUBJECT:** Department of the Army Permit Application Number SAM-2009-01768-DMY, Mississippi State Port Authority

Mississippi State Port Authority  
Attention: Mr. Jonathan Daniels  
2510 14<sup>th</sup> Street, Suite 880  
Gulfport, Mississippi 39501

Dear Mr. Daniels:

In an effort to maintain timely progress on the Environmental Impact Statement (EIS) for the Mississippi State Port Authority's (MSPA) Port of Gulfport Expansion Project (PGEP), we would like to share the Corps' understanding of the status of the currently proposed project. By letter dated April 8, 2013, the MSPA requested that PGEP be modified to include widening and deepening of the existing Federal Navigation Channel (FNC). However, it is our understanding this is no longer the MSPA's proposed project. Based on meetings held with the MSPA and authorized representatives over the timeframe of August 5, 2014, through the present date, it is our understanding that widening and deepening the FNC is no longer a requirement of known incoming tenants. Moreover, on November 11, 2014, MSPA stated that they had no intention to expand the FNC or maintain an expanded FNC without first receiving proper prior Federal approval and funding. Therefore, the purpose and need of the project has changed, and no modification to the FNC is proposed as part of the PGEP. It is our understanding that if future needs arise, modification to the FNC may be pursued as a single and complete project. The currently proposed action at the Port consists of the following: filling approximately 202 acres (ac) (160 ac at the end of the west pier; 9 ac in the north harbor, 15 ac at the end of the east pier and 18 ac east of the FNC for the creation of breakwaters); removal of 3.7 million cubic yards (mcy) of material by dredging for the placement of 202 ac of proposed fill on more suitable foundation; and dredging of another 3.7 mcy of material south of the existing turning basin to expand the capacity of the turning basin. Discussions in the EIS regarding modifications to the FNC will be limited to cumulative impacts and reasonably foreseeable future actions.

Based on a letter dated January 7, 2015, from the Mississippi Department of Marine Resources (MDMR), we are satisfied that MDMR has demonstrated that the Biloxi Marsh Complex (BMC) is a single and complete project with independent utility which

could potentially be utilized for sediment disposal should it receive approvals from the State of Louisiana and USACE, New Orleans District. It is our understanding that BMC is your preferred option for sediment disposal, and the Pascagoula Ocean Dredged Material Disposal Site (ODMDS) is your secondary option for disposal. Please understand the Dredged Material Management Plan (DMMP) will need to be updated so it may be submitted to the Environmental Protection Agency (EPA) in order to utilize the ODMDS site under Section 103 of the Marine Protection, Research, and Sanctuaries Act, and that both BMC and Pascagoula ODMDS must be fully evaluated in the Final EIS.

It is our understanding based on meetings held with MSPA and its authorized representatives over the timeframe of May 11, 2012, through the present date that the National Marine Fisheries Service (NMFS) may require compensation for impacts to Essential Fish Habitat (EFH) for fill, and the MSPA is proposing the creation of approximately 200 ac of marsh in BMC to meet the NMFS requirement. Please provide documentation from MDMR that MSPA has been given permission to create 200 ac of marsh in the proposed BMC disposal area.

Over the timeframe of October 16, 2014, through the present date, we have requested a technical memorandum from the MSPA detailing the PGEP sediment and structures modeling analysis. A draft memorandum was received from MSPA on December 16, 2014, and we provided comments on December 19, 2014. Please provide the revised technical memorandum addressing our comments.

It is our understanding based on meetings held with the MSPA, authorized representatives and incoming tenants over the timeframe of August 5, 2014, through the present date that the south end of the east pier may be modified to fit the needs of a new tenant. In order for us to fully evaluate the impacts of the PGEP and to fully disclose the project to the public; please provide updated drawings, figures and quantities which accurately depict the proposed configuration of the east pier.

In summary, please provide us with documentation from MDMR that MSPA has been given permission to create 200 ac of marsh in the proposed BMC disposal area, a revised technical memorandum, a written description of all proposed work which will include an updated set of plans and drawings that accurately depicts all proposed work at your facility. Without these items we will be unable to produce a DEIS for comments and review.

A copy of this letter is being provided to the following recipients: Mississippi State Port Authority, Attention: Mr. Nick Foto, Jr., 2510 14<sup>th</sup> Street, Suite 1450, Gulfport, Mississippi 39501, and CH2M Hill, Attention: Ms. Elizabeth Calvit, at 2410 14<sup>th</sup> Street, Suite 1100, Gulfport, Mississippi 39501.



If our understanding of any the above stated matters is incorrect, or if you wish to clarify any statements in this letter, please respond in writing by *14 days from the letterhead date*. A timely response is necessary in order to maintain timely progress on the project. We look forward to continuing to work together in order to address the needs and requirements of this project. Should you wish to discuss this letter or have any questions, please do not hesitate to contact me at (251) 690-2658 or by email at [craig.j.litteken@usace.army.mil](mailto:craig.j.litteken@usace.army.mil).

Sincerely,

  
Craig J. Litteken, PMP  
Chief, Regulatory Division



## **Appendix B**

# **Gulfport Container Volume Projections**



**DRAFT**  
**GULFPORT CONTAINER VOLUME PROJECTIONS**

Prepared for:

Atkins

Prepared by:

**PARSONS**  
**BRINCKERHOFF**

January 2012





## Contents

---

	Page
List of Tables .....	iii
<b>I. INTRODUCTION.....</b>	<b>1</b>
<b>II. RECENT HISTORY AND CURRENT STATUS .....</b>	<b>1</b>
IMPORTANCE OF IMPORTS .....	1
PRINCIPAL GULFPORT TRADE REGIONS AND CONTAINERIZED COMMODITIES .....	3
<b>III. BASELINE CONTAINER PROJECTION .....</b>	<b>4</b>
<b>IV. LOW GROWTH SCENARIO .....</b>	<b>6</b>
<b>V. HIGH GROWTH SCENARIO .....</b>	<b>7</b>
<b>VI. OPTIMISTIC GROWTH SCENARIO .....</b>	<b>8</b>
NORTHEAST ASIA .....	8
Panama Canal Expansion .....	9
Chicago .....	10
Memphis .....	11
Atlanta .....	11
Conclusion for Northeast Asia .....	11
EUROPE.....	12
AMERICAS.....	13
Inland Markets Where Gulfport Can Be Most Competitive.....	14
Local Trucking Markets .....	15
Longer Distance Rail and Long-Haul Truck Markets (>400 miles) .....	15
Summary of Rail Transportation.....	17
Ocean Carrier Services and Country Origins .....	17
Americas Growth Scenario .....	18
OPTIMISTIC GROWTH SCENARIO SUMMARY .....	18
<b>VII. PROJECTION SUMMARY .....</b>	<b>18</b>
<b>Appendix: The Freight Analysis Framework, Version 3: Overview of the FAF3 National Freight Flow Tables</b>	

**Figures**

	<b>Page</b>
1	TEU Volumes for Largest Gulf Ports.....2
2	Container Volume for Central Gulf Ports.....2
3	Gulfport Container Imports Have Historically Exceeded Exports .....3
4	Crowley Marine Liner Services .....4
5	Baseline Projection of Gulfport Container Volumes in TEUs .....6
6	Low Growth Gulfport Container Volumes Scenario in TEUs .....7
7	High Growth Gulfport Container Volume Scenario in TEUs .....8
8	Costs per TEU and Transit Times for Reaching Inland Regions from Northeast Asia (Shanghai).....10
9	CMA Pacific Express 3 Round-the-World Liner Service .....12
10	Canadian National Intermodal Services.....14
11	KCS Rail Routes Showing other Class I Rail Routes.....16
12	Hapag-Lloyd Liner Service.....17
13	Optimistic Growth Scenario for Gulfport Container Volumes in TEUs .....19

**Tables**

	<b>Page</b>
1	Projections of U.S. Waterborne Imports Entering the U.S. through Mississippi.....5

## I. INTRODUCTION

This document provides container volume projections to support the Environmental Impact Statement (EIS) for the Port of Gulfport (Gulfport).

The report begins with a brief review of container volumes from a historical perspective and current container cargo flows through Gulfport. Later sections of the report provide projections for Gulfport container volumes through the year 2060. Container volume scenarios include:

- **Baseline**, assuming no substantial changes in commodities handled, changes in liner container services, or other factors that could positively or negatively affect container volumes beyond increases that could be expected due to economic growth and consumption of products.
- **Low Growth**, assuming lower growth than that included in the baseline projection or loss of current market share.
- **High Growth**, assumes higher growth than the baseline projection.
- **Optimistic**, includes growth due to expansion into new markets.

## II. RECENT HISTORY AND CURRENT STATUS

Gulfport and other ports in the Gulf of Mexico (Gulf) have grown more modestly than the Port of Houston over the past two decades (Figure 1).

Gulfport's container volumes have grown over the past two decades first reaching the 200,000 twenty-foot equivalent unit (TEU) level in 2003 and then attaining a new peak of 223,740 TEUs in 2010. The Gulfport has generally maintained the 200,000 level of volume since 2003, representing about 0.5% of the U.S. total. Hurricane Katrina caused a significant disruption in volume and shares of the U.S. total, with declines in Gulfport as well as New Orleans in 2005 (Figure 2).

### Importance of Imports

As is the case for many other U.S. ports, Gulfport's container trade is dominated by imports, with imports exceeding exports by a ratio of over 2 to 1 in terms of value (Figure 3) and also in terms of tons. This imbalance means that container trade is driven primarily by imports with empty containers generally comprising a large share of containers outbound from U.S. ports.

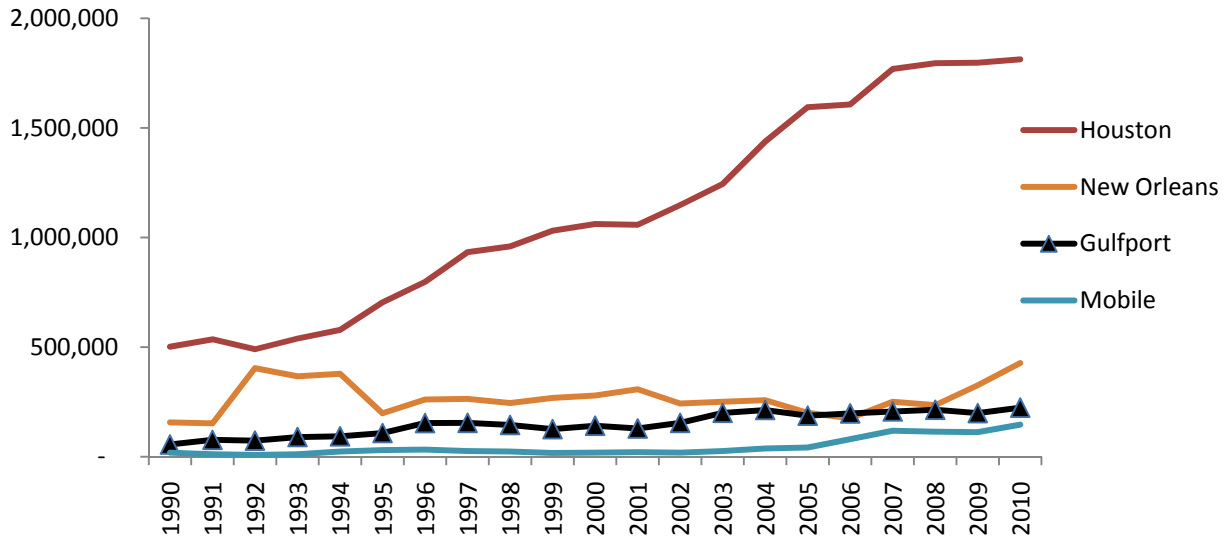

Source: American Association of Port Authorities (AAPA).

Figure 1. TEU Volumes for Largest Gulf Ports

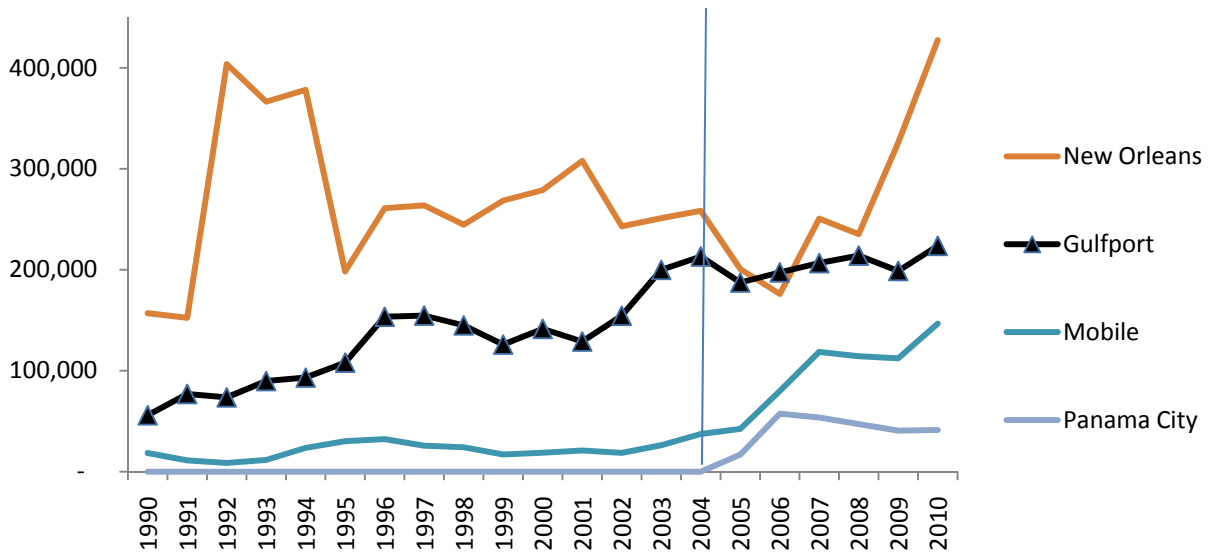

Source: AAPA.

Figure 2. Container Volume History for Central Gulf Ports

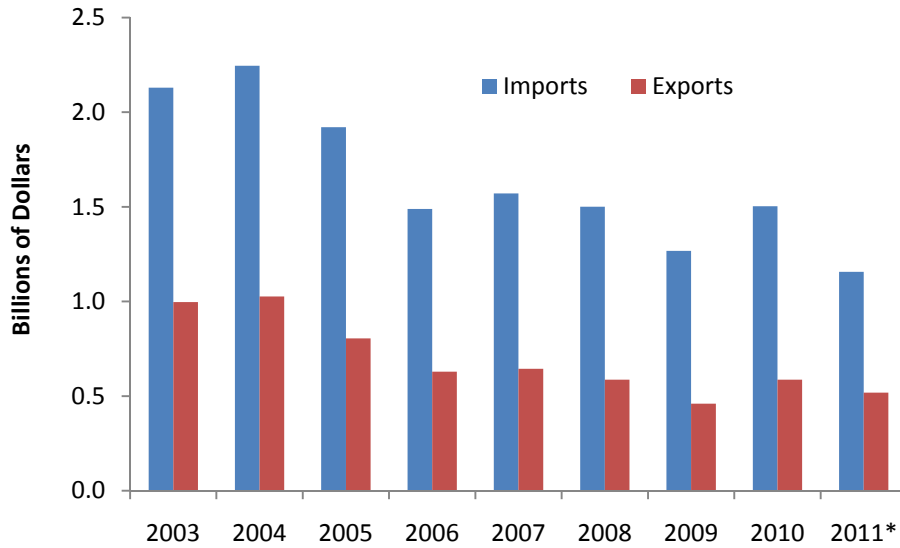

Source: U.S. Census Bureau and PB analysis  
 \* 2011 data is year to date through September

Figure 3. Gulfport Container Imports Have Historically Exceeded Exports

### Principal Gulfport Trade Regions and Containerized Commodities

Based on U.S. Census data for 2010, Gulfport shares of U.S. containerized import tons by major world region are as follows:

- **Total U.S. Imports** **0.7%**
- Americas (except Mexico) 2.7%
- Mexico 1.0%
- Northeast Asia 0.0%
- Europe 0.0%
- Southeast Asia/Oceania 0.8%
- South Asia 0.0%

From this data it can be seen that Gulfport’s principal trade is with countries to the south of the United States rather than with other world regions. Major import commodities and the origin regions are:

- Bananas (Central America)
- Apparel (Central America)
- Titanium ores (ilmenite) (Australia/Africa)



---

Container liner services handling imports are currently provided by three carriers: Dole, Chiquita, and Crowley (Figure 4).

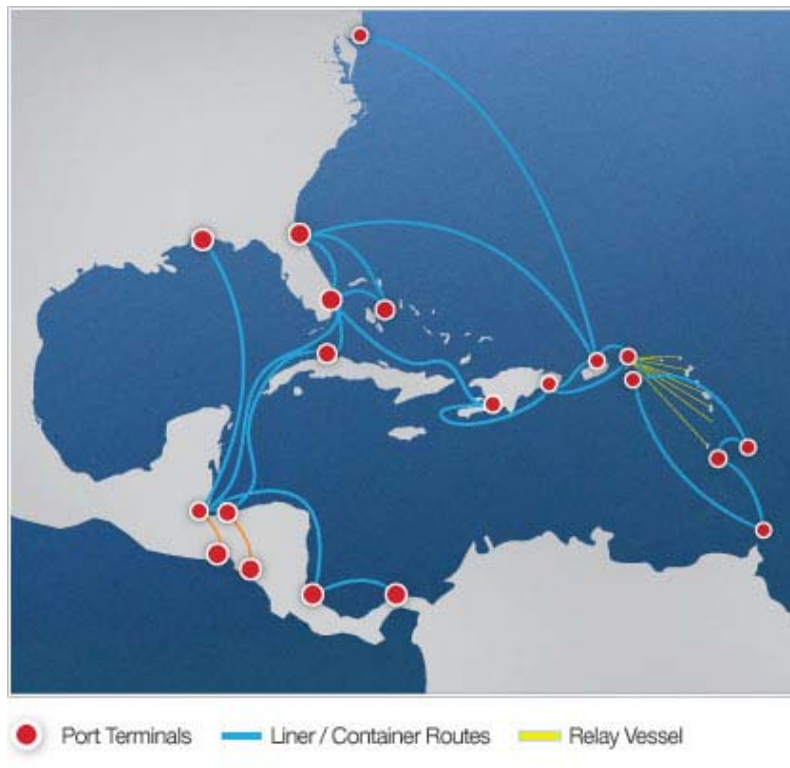

Figure 4. Crowley Marine Liner Services

### III. BASELINE CONTAINER PROJECTION

A baseline container volume projection has been derived from the most recent Federal Highway Administration (FHWA) Freight Analysis Framework (FAF) database (released January 2011). This database includes forecasts through 2040 of dollar value and tons for 43 product groups defined by Standard Classification of Transported Goods (SCTG) commodity groups between 123 domestic geographic zones, by mode, for movement of domestic goods, imports, and exports (see Appendix for a further description). The State of Mississippi is one of the FAF zones both for domestic origins and destinations and also a U.S. gateway for imports and exports.

Forecasts of import tons through Mississippi have been used to project total container volumes for the Port of Gulfport, with Gulfport representing nearly all Mississippi container traffic. Since FAF data does not directly identify container volumes, 19 FAF commodity groups that are most heavily containerized (Table 1) have been used to project container volumes. Forecasted growth rates for total waterborne import tons for these 19 product groups were applied to 2010 Gulfport TEU volumes to produce the baseline projection. TEU volume will grow to a projected 564,000 in 2040 under this baseline scenario, an increase of over 150% from 2010 volumes of 224,000 TEUs (Figure

5). Volumes for 2040 through 2060 are extrapolated based on the projected 2035 to 2040 growth rate of 2.7%. Projected volumes are 1.05 million TEUs in 2060.

Table 1. Projections of U.S. Waterborne Imports Entering the U.S. through Mississippi  
Thousands of Metric Tons  
(2010 data is interpolated from 2007 and 2015 FAF forecast values)

SCTG	2007	2010	2015	2020	2025	2030	2035	2040
Container	1,052	1,110	1,206	1,465	1,768	2,097	2,459	2,872
01 Other ag. prods.	659	709	792	978	1,197	1,433	1,699	1,996
03 Meat/seafood	1	1	1	1	1	1	1	1
04 Milled grain prods.	26	27	29	35	41	48	56	66
05 Other foodstuffs	51	55	62	65	68	72	76	81
06 Tobacco prods.	0	0	0	0	0	0	0	0
13 Chemical prods.	0	1	1	1	1	1	1	2
14 Plastics/rubber	7	7	7	9	11	14	17	20
16 Wood prods.	98	90	75	83	91	100	109	120
17 Newsprint/paper	0	0	0	0	0	0	0	0
18 Paper articles	0	0	0	0	0	0	0	0
19 Printed prods.	0	0	0	0	0	0	0	0
20 Textiles/leather	144	153	170	198	230	265	306	356
23 Articles-base metal	4	4	5	6	7	8	10	12
24 Machinery	54	54	55	76	101	131	156	186
25 Electronics	6	7	8	11	14	18	21	25
26 Motorized vehicles	0	0	0	0	0	0	0	0
28 Precision instruments	0	0	0	1	1	1	1	1
29 Furniture	1	1	1	1	2	3	3	4
30 Misc. mfg. prods.	1	1	1	1	1	1	1	2

Source: FHWA FAF database and PB analysis

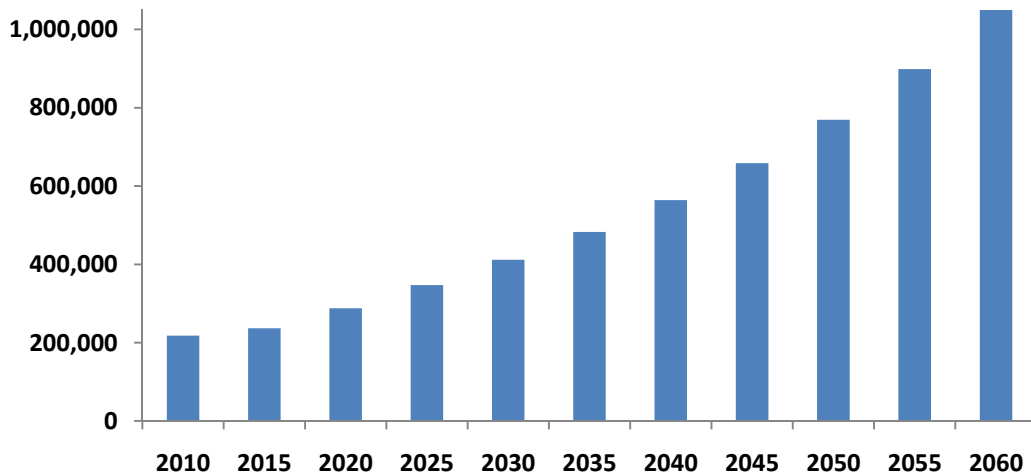

Source: PB analysis.

Figure 5. Baseline Projection of Gulfport Container Volumes in TEUs

The baseline volume forecast is essentially a status quo scenario with growth projected in current markets and commodity flows. The compound average annual growth rate for 2010 to 2040 aggregate volumes is 3.3%. It should be noted that the baseline scenario assumes the Port of Gulfport Restoration Project is completed.

Growth and tonnage of “other agricultural products” (which include fresh fruit and vegetables) comprises a large and growing portion of Gulfport’s baseline projection, with above-average growth also in machinery. “Textiles/leather” (which includes apparel) is a large volume category with slightly below-average growth projected.

#### IV. LOW GROWTH SCENARIO

A low growth scenario for Gulfport container volumes is derived from the baseline projection but includes lower long term growth, i.e., a reduction of 0.5% per year in average annual growth, or 2.8% rather than 3.3%. Such lower growth could result from lower consumption of goods, alternative sourcing of goods such as apparel, or successful competition from other ports. Under this scenario, container volumes would reach just under 500,000 TEUs in 2040 or 2.25 times 2010 volumes. Volumes would be 915,000 TEUs in 2060.

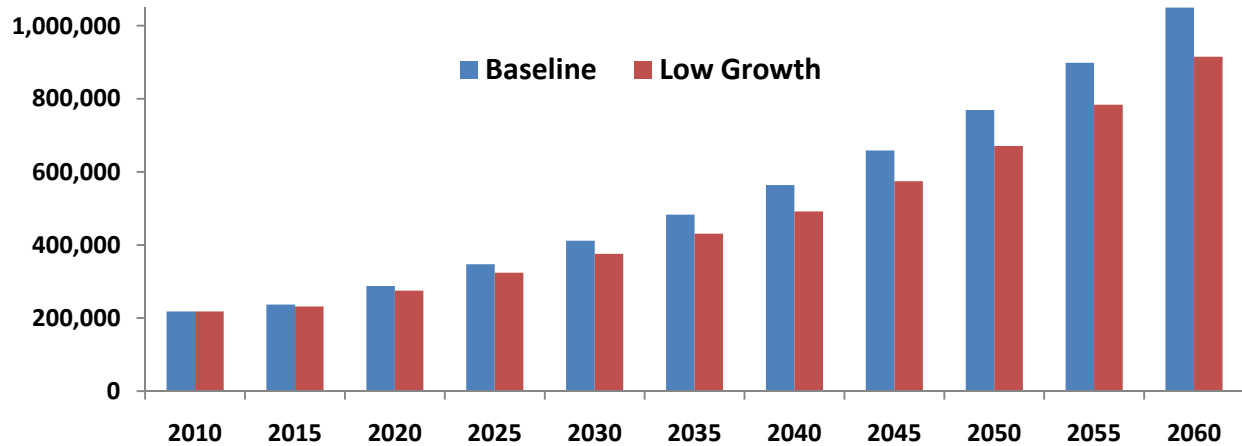

Source: PB analysis.

Figure 6. Low Growth Gulfport Container Volume Scenario in TEUs

## V. HIGH GROWTH SCENARIO

A high growth scenario for Gulfport container volumes is also derived from the baseline projection but includes higher long term growth, an increase of 0.5% per year in average annual growth (e.g. 3.8% rather than 3.3% growth in the baseline projection for 2010 to 2040).

Higher growth could result from increased consumption of goods due to higher U.S. economic growth. Another possibility is that volumes of Central American imports could increase more than the projection included in the baseline scenario. This could occur as a result of shifts in sourcing (“near-shoring”) of apparel imports from Central America rather than from China, Southeast Asia, or other regions. Finally, growth in Gulfport import volumes from the Americas could result from increasing shares of current Central American markets, for example by attracting more banana, apparel, or other product imports. Such increases could be achieved by successfully competing with other ports based in part on Gulfport’s improved port facilities and supporting inland infrastructure.

Under this scenario, container volumes would reach 650,000 TEUs in 2040, or 3.0 times 2010 volumes, and reach 1.2 million TEUs in 2060.

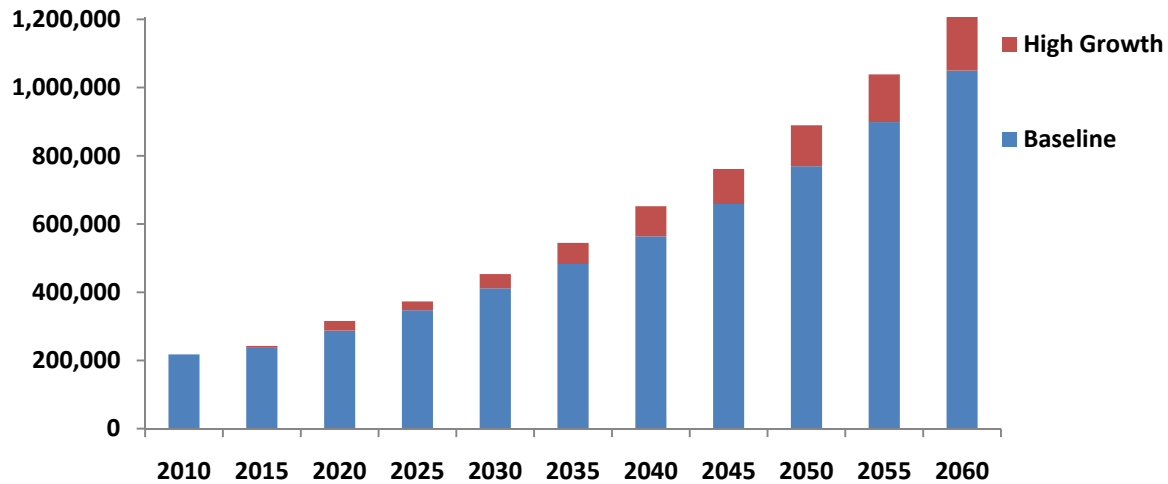

Source: PB analysis.

Figure 7. High Growth Gulfport Container Volume Scenario in TEUs

## VI. OPTIMISTIC GROWTH SCENARIO

Potential scenarios for additional growth based on expanded markets have been examined on a world region basis, where Gulfport might be able to increase container traffic particularly for U.S. imports which drive carrier services and calls.

Regions examined (and share of 2010 U.S. import container tons) include:

- Northeast Asia (Panama Canal expansion) 46%
- Europe 18%
- Americas, including Mexico 17%

Other world regions have small volumes of U.S. imports (a total of 19%)

### Northeast Asia

Gulfport does not currently have Northeast Asia liner services and thus has a 0% share of total U.S. import tons. (Northeast Asia includes China, Hong Kong, Japan, South Korea, and Taiwan). U.S. container imports from Northeast Asian countries move principally through West Coast ports; 69% of containerized Northeast Asian import tons in 2010 were received on the West Coast, according to U.S. Census data. Based on FHWA FAF estimates, West Coast ports have dominant shares of U.S. inland markets as far east as Ohio, Memphis, and Dallas.



---

Over 26% of containerized import tons move through East Coast ports with the remaining 5% through Gulf ports. Gulf port traffic is generally focused on large markets along the Coast (especially the Houston region).

### *Panama Canal Expansion*

Increased U.S. container import volumes from Northeast Asia through U.S. ports is a much anticipated effect of Panama Canal expansion expected to be completed by 2015. There are, however, five factors that are likely to limit these impacts for Gulf ports.

First, there is no reason to believe that aggregate container volumes will increase due to Panama Canal expansion. Lowered transportation costs that will result from use of larger ships will represent only a tiny fraction of overall product value, limiting any induced increases in consumption of imported goods to near zero. Thus import container volumes are a zero sum game with increased shares of cargo handled by some ports necessarily offset by decreases in others. Of course as aggregate U.S. volumes increase over time, ports that lose shares may still experience increased volumes but at a slower rate than ports gaining share. It is generally expected that some volumes will shift from West Coast ports to East and Gulf coast ports.

The second factor affecting potential shifts in container volumes is the potential size of cost reductions that may result from the use of larger ships (up to about 13,000 TEU capacity) that will be able to transit the expanded Panama Canal compared to the current 5,000 TEU “Panamax” maximum ship size able to transit the Panama Canal. It is expected that maximum transportation cost reductions may amount to several hundred dollars per TEU for goods moved to the U.S. East Coast where the largest new Panamax ships are likely to be deployed. However, cost reductions will likely be smaller for goods moving to the Gulf Coast that are likely to be carried by smaller ships given the shallower depths available in Gulf ports.

The third factor that may limit volume impacts is that transportation service providers are likely to retain a significant share of total cost reductions. In particular, liner companies will attempt to keep part of the savings to help pay for newer larger ships. In addition, through tolls and fees the Panama Canal Authority is likely to retain some of the cost savings to not only pay for canal expansion but also to maximize revenues and returns from Panama’s investments. To the extent that cost savings are retained, the cost reduction benefits to importers will be reduced, and this will dampen shifts that might occur due to such cost reductions.

Fourth, shifts in container volumes are likely to be limited to lower valued products where longer transit times required for Panama Canal transit are a less significant factor than marginal reductions in shipping costs. Shippers will continue to value quicker transit times for high value goods where inventory carrying costs and time to market are critical.

Finally, even for lower value products, U.S. regions where Gulf Coast ports provide lower total transportation costs are limited (Figure 8). Example destinations discussed below include Chicago, Memphis, and Atlanta.

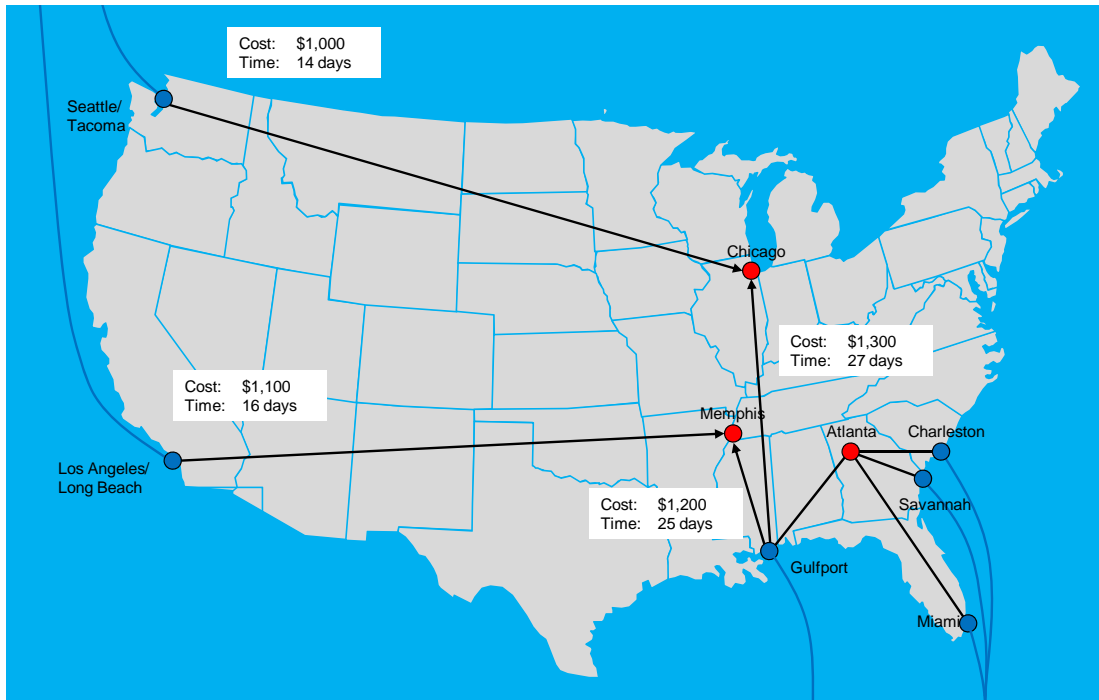

Source: PB analysis.

Figure 8. Costs per TEU and Transit Times for Reaching Inland Regions from Northeast Asia (Shanghai)

### Chicago

For shipments from Shanghai to Chicago through Seattle-Tacoma total ocean and rail costs are about \$1,000 per TEU (\$600 ocean and \$400 rail), and total transit time is about 14 days (excluding port and other dwell times). Note that costs are based on estimated costs for transportation services rather than rates which can fluctuate widely based on market conditions.

While rail distances from Gulf ports to Chicago are shorter, ocean distances are much greater given the Panama Canal route. As a result, ocean shipping costs using current Panamax ships would be much larger and outweigh the lower rail cost by about \$300 per TEU. Transit time would also be about 13 days longer. The cost difference would be greater if a larger 8,000 to 10,000 TEU ship were used for the Transpacific ocean transport to Seattle as opposed to the ships that likely will be used to serve Gulf ports. Thus, for goods moving from Northeast Asia to Chicago via the Panama Canal and a Gulf port rather than through the West Coast, the cost would be greater and the transit time longer, making such routing highly unlikely.

---

## *Memphis*

The cost and transit time differentials are smaller for containers moving to Memphis than those destined for Chicago, but the results are similar. The total cost for ocean and rail transportation is about \$100 less per TEU for the West Coast route, and the difference in transit time is about 9 days longer making routing through Gulf ports unlikely.

## *Atlanta*

For reaching Atlanta, ocean transportation costs to the Ports of Savannah (and/or Charleston) may be lowered due to Panama Canal expansion depending in part on whether these ports are dredged to depths to allow calls by larger container ships. If this occurs, costs could be lowered for moving goods to Atlanta through these ports, effectively strengthening Savannah's position in reaching the Atlanta market.

Miami's position as a possible competitor to South Atlantic ports will be enhanced given developments underway for deepening the Port of Miami and improving rail connections from Miami to Atlanta. If South Atlantic ports are not dredged to adequate depths and otherwise prepared to handle larger ships, Miami's competitive position would be strengthened further.

Gulfport and other Gulf ports will continue to be disadvantaged in reaching Atlanta due to higher inland transportation costs associated with longer highway and rail distances compared to connections through Savannah.

## *Conclusion for Northeast Asia*

The analysis outlined above suggests that Gulfport's potential for increased Northeast Asian imports is likely limited to serving the Gulf Coast states of Texas, Louisiana, Mississippi, and Alabama. Given the relatively short distances involved, these markets would tend to be served through trucking, meaning that improved rail connections to Hattiesburg will have little positive impact.

A summary of Gulfport's potential for reaching these Gulf Coast markets is as follows:

- Texas is a very large market that will continue to be served primarily by Houston and other Texas Gulf Coast ports where goods are not imported through the West Coast. Houston will continue to be the principal Gulf port of call for most Northeast Asia liner services given its large local market and significant exports.
- Louisiana is a very small destination market compared to Houston. Small volumes are imported through New Orleans, with most volume moving through Southern California ports.
- Mississippi is also a very small market, largely served through Southern California ports.

- 
- Alabama destinations are served to a small degree through Mobile in addition to Southern California and Georgia ports. Reaching Alabama destinations from Gulfport will always require longer trucking distances than from Mobile, minimizing this modest potential.

In summary, there is limited potential in local markets that could be served by Gulfport, and this potential would require development of local markets (e.g., distribution centers) and a willingness of carriers to add Gulfport as a call on Gulf services (like those currently calling Houston and Mobile) (Figure 9). This may be a chicken and egg situation, with market development requiring better access to shipping services, and new carrier services dependent on new market developments. The positive aspect of this is that Gulfport’s revitalization could help make such developments possible.

Based on these conclusions, negligible growth in container volumes is expected for Northeast Asian trade for Gulfport, and increases in container volumes along this trade lane are not included in an optimistic scenario.



Figure 9. CMA CGM Pacific Express 3 Round-the-World Liner Service

## Europe

Gulfport currently has no container liner services from Europe and therefore handles 0% of total U.S. containerized import tons. Imports from Europe are to a large degree an east-west mirror image of imports from Northeast Asia that move primarily through West Coast ports. About 70% of imports from Europe are transported through East Coast ports to U.S. inland destinations according to U.S. Census data. An examination of volumes for containerized commodity groups from FAF data (see Table 1) indicates that 56% of import tons from Europe are destined for states along the Atlantic seaboard with 84% of this volume moving through Atlantic Coast ports. Another 23% of European imports are destined for North Central states (from Arkansas and Tennessee north to the upper Midwest), and over 80% of this volume is imported through East Coast states.

---

A smaller 14% of U.S. import tons from Europe move through Gulf ports, although this represents a larger share than their 5% share of imports from Northeast Asia. Of the total Gulf port volume of European imports, nearly 80% moves through Texas ports. This occurs for two reasons:

- The Texas market is large and well-served by Texas ports (compared to East Coast ports).
- The Port of Houston acts as a gateway to California markets allowing relatively quick and less expensive transportation than Panama Canal services.

In theory, Panama Canal expansion could lower costs for transporting goods from Europe to the West Coast, decreasing the Gulf Coast share of such imports. However, since much larger ships are unlikely to be deployed on Europe-U.S. West Coast routes and, in any case, cost differentials would tend to be small, little impact on volumes is expected. If volumes were to decrease, this impact would be focused on Texas ports.

Given the dominance of U.S. East Coast ports in handling imported containerized goods from Europe destined for the large markets in Atlantic seaboard and North Central states, and the lack of cost reduction incentives that could change these patterns, potential for increased container volumes from Europe through Gulfport or Gulf ports in general is also expected to be negligible.

## **Americas**

Imports from the Americas including Mexico, the Caribbean, Central America, and South America accounted for about 17% of total U.S. waterborne import tons in 2010 according to U.S. Census data, nearly the same as imports from Europe.

Compared to East-West trade lanes outlined above (Northeast Asia and Europe), Gulfport is likely to be far more competitive for North-South Americas container trade due to the Gulf's relative geographic proximity to these markets. Inland regions for which transportation services could be most competitive include the Central Gulf states of Louisiana, Mississippi, and Alabama but extend north in the Mississippi Valley to Illinois, Indiana, and neighboring states, essentially the southern shaded area shown in Canadian National's key markets map shown on Figure 10.

U.S. containerized imports from the Americas (excluding Canada) represent a large share Gulf Coast ports' container cargo, 41.3% of the total tons moving through ports in the Gulf Coast (including Texas, Louisiana, Mississippi, and Alabama).

Import tons originating in Caribbean, Central American, and South American countries represent a large portion of this trade, 15.4% of total U.S. containerized imports in 2010 and 38% of the cargo moving through Gulf Coast ports.

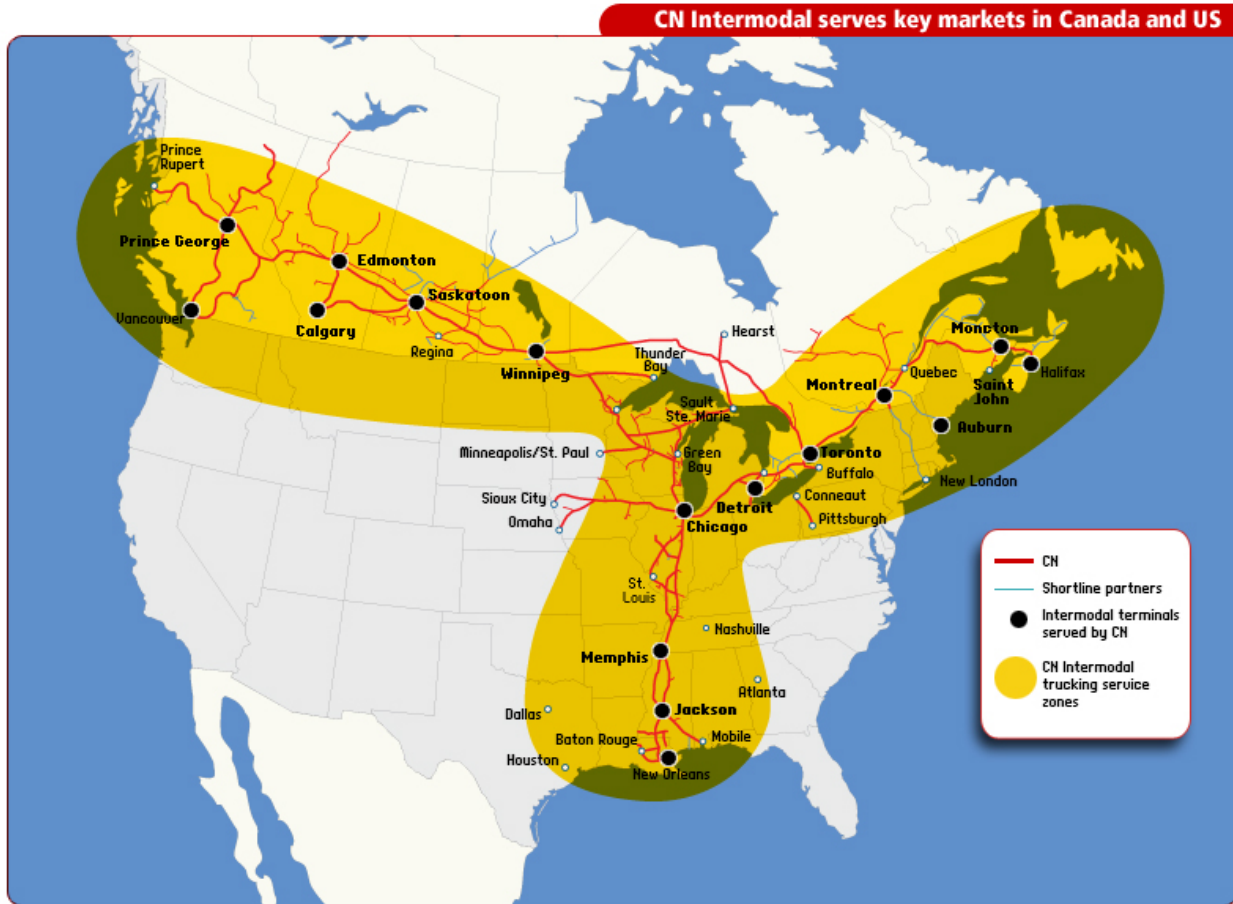

Figure 10. Canadian National Intermodal Services

While Mexico is one of the United States' largest trading partners, containerized imports from Mexico represent a much smaller 1.2% share of U.S. totals since most imports from Mexico are transported by truck or rail. Gulf state ports also handled 38% of waterborne imports from Mexico, with this cargo representing 3% of Gulf port totals.

Given the relative importance of import volumes compared to exports, imports from the Americas represents the principal driver of roughly 1 million TEUs per year moving through Gulf ports. Based on FHWA FAF forecasts this total will grow to 1.4 million TEUs in 2020 and 2.0 million TEUs in 2030.

### *Inland Markets Where Gulfport Can Be Most Competitive*

For Gulfport to be competitive it must be part of an effective transportation network linking countries and products with U.S. inland markets. Components of this network include inland transportation (trucking and rail) and ocean liner services connecting country sources with



---

Gulfport and inland transportation services. Sections that follow examine inland transportation followed by a view of liner services.

### ***Local Trucking Markets***

Within current local trucking markets (primarily the Central Gulf Coast states of Texas, Louisiana, Mississippi, and Alabama) Gulfport is likely to be most competitive in areas directly to the north:

- In Texas, Houston and other Texas ports are likely to be most competitive due to shorter highway distances. Houston's dominance as a port of call is also a factor.
- In Alabama and areas to the east, Mobile has an advantage in highway distances and costs.
- Regions to the north, including areas in Mississippi and Louisiana and Memphis (which is 370 miles from Gulfport), may be competitive from Gulfport depending on local trucking market dynamics. However, given the small size of these local regional markets and competition from New Orleans and Mobile, overall growth potential is likely to be limited.

### ***Longer Distance Rail and Long-Haul Truck Markets (>400 miles)***

Gulfport's improved rail connection to Hattiesburg on Kansas City Southern (KCS) as shown on Figure 11 offers an opportunity to reach U.S. Midwest markets through Gulfport that has previously been impractical due to limitations of the current rail line. This means that Gulfport could be competitive with other Gulf ports and possibly with Atlantic Coast ports for serving these inland regions. Specific advantages by railroad could be:

#### **For Kansas City Southern:**

- Gulfport could provide an alternative from New Orleans north to Tennessee, which currently requires much longer routing through Shreveport. This route would involve use of haulage rights on CN's rail line between Hattiesburg and Jackson.
- Likewise, Gulfport could be an alternative from New Orleans, West Lake Charles, and Texas to regions west and north including Shreveport, Dallas, Kansas City, and St Louis.
- Either alternative requires haulage on Canadian National that may limit KCS interest.

#### **For Norfolk Southern (NS), KCS connection in Hattiesburg provides:**

- Alternative to the NS route out of New Orleans to Birmingham and regions to the north.
- Alternative to the NS route from Mobile to Birmingham and north.
- Use of either of these alternatives would require use of the KCS connection from Gulfport to Hattiesburg rather than direct service on NS-only routes.

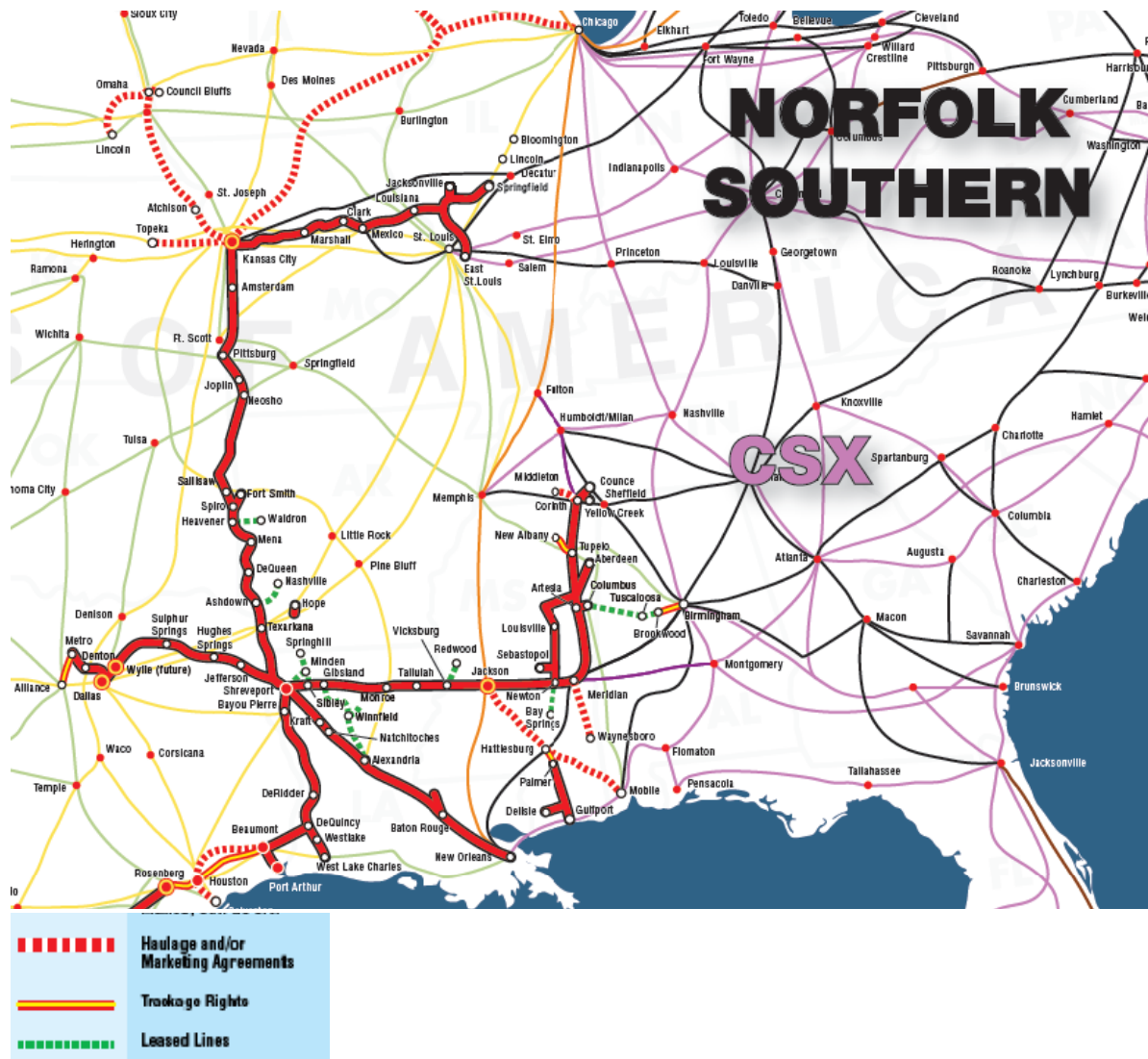

Source: Kansas City Southern.

Figure 11. KCS Rail Routes Showing other Class I Rail Routes

**For Canadian National, KCS connection provides:**

- Canadian National has routes from both New Orleans and Mobile north through Jackson. The KCS connection from Gulfport to Hattiesburg would provide an alternative for all destinations to the north from New Orleans and Mobile
- Use of the KCS link would require KCS to share service rather than services solely on CN routes

---

### *Summary of Rail Transportation*

The upgraded KCS rail link between Gulfport and Hattiesburg is a necessity for Gulfport to be able to competitively serve U.S. inland regions from Gulf Coast states north to the U.S. Midwest. However, this development alone will not be sufficient to guarantee success in reaching these markets because the rail link will need to offer competitive advantages to the railroads involved in providing services. Shared service between KCS and either NS or CN may not provide significant incentives to the NS or CN partners to induce shifts from current ports and routes.

### *Ocean Carrier Services and Country Origins*

In addition to shifts in inland transportation services, Gulfport will need to induce ocean carriers to modify their services to include calls at Gulfport, either by adding Gulfport to an existing service rotation or by replacing another port on a service. Given that Gulfport has established services from Central America provided by Dole, Chiquita, and Crowley, such new service patterns will need to include links from the Caribbean or South America if Gulfport is to increase its share of the overall Americas market.

Figure 12 displays a South American service offered by one international carrier. As noted earlier most such services include Houston as a primary port of call. In the example service the next port of call is New Orleans.



Figure 12. Hapag-Lloyd Liner Service

---

## *Americas Growth Scenario*

In addition to potential growth in Americas trade included in the High Growth scenario described earlier, growth in Gulfport's market share could also occur by attracting new container services from the Caribbean or from large South American markets. Whether from current regional markets or from reaching new regional markets, growth in Gulfport volumes from America's trade will likely depend on:

- Successfully capitalizing on Gulfport's improved rail connections to U.S. inland markets
- Inducing modifications to liner companies service patterns

These developments are likely to happen in concert, with ocean carriers and railroads cooperating to improve competitive overall services in response to market developments.

Gulfport currently handles about 1.4% of total U.S. waterborne imports from the Americas, largely in banana and apparel imports from Central America. If Gulfport could double its share of total America's imports in 2020 this would result in new container volumes of about 200,000 TEUs in that year. Given market growth this new volume would increase by 300,000 TEUs by 2030 and 400,000 TEUs by 2040. While a small portion of this share increase could be won from Atlantic Coast and Florida ports, most of this increase in share would likely need to be gained in competition with neighboring Gulf Coast ports including Houston.

## **Optimistic Growth Scenario Summary**

Based on the analyses outlined above, the optimistic growth scenario includes potential new volume in America's trade including that assumed in the high growth scenario, but no growth from Northeast Asia or European trade. The optimistic growth scenario shows total container volumes growing to just under 1 million TEUs in 2040 and 1.7 million TEUs in 2060 (Figure 13).

## **VII. PROJECTION SUMMARY**

A baseline projection for Gulfport's container volume shows average annual growth of 3.3% through 2040, largely based on increasing imports from Central America, i.e., growth in banana and apparel imports. TEU volumes would total 0.6 million in 2040 growing to 1.0 million in 2060.

A low growth projection of container volumes is based on relatively low growth of 2.8% in current markets through 2040. TEU volumes would total under 0.5 million in 2040 increasing to 0.9 million in 2060.

A high growth scenario of container volumes is based on higher growth of 3.8% through 2040. TEU volumes would total 0.7 million in 2040 and 1.2 million in 2060.

An optimistic view of container volumes is based not on capturing U.S. imports from Northeast Asia or Europe, but rather on a doubling in Gulfport’s share of imports from the Caribbean, Central America, and South America. Such share increases would require successful competition with other Central Gulf ports, in part based on improved capabilities for reaching inland markets by rail. TEU volumes would reach just under 1.0 million in 2040 and 1.7 million in 2060.

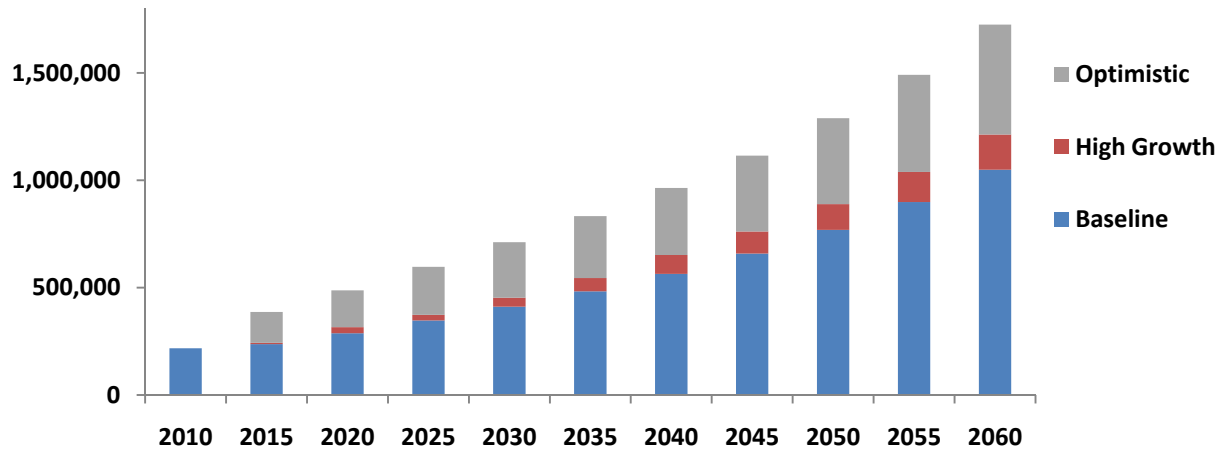

Source: PB analysis.

Figure 13. Optimistic Growth Scenario for Gulfport Container Volumes in TEUs





## **Appendix**

### **The Freight Analysis Framework, Version 3: Overview of the FAF3 National Freight Flow Tables**



# **The Freight Analysis Framework, Version 3: Overview of the FAF<sup>3</sup> National Freight Flow Tables**

*PREPARED FOR:*  
FEDERAL HIGHWAY ADMINISTRATION  
Office of Freight Management and Operations  
Federal Highway Administration  
U.S. Department of Transportation  
1200 New Jersey Ave, SE,  
Washington, DC 20590

*October 28, 2010*

*PREPARED BY*  
*Frank Southworth*  
*Diane Davidson*  
*Ho-Ling Hwang*  
*Bruce E. Peterson*  
*and*  
*Shih-Miao Chin*  
OAK RIDGE NATIONAL LABORATORY  
Oak Ridge, Tennessee 37831-6285  
managed by  
UT-BATTELLE, LLC  
for the  
U.S. DEPARTMENT OF ENERGY  
Under Contract No. DE-AC05-00OR22725



## TABLE OF CONTENTS

1. Introduction.....	1
1.1 Purpose of This Document.....	1
1.2 FAF <sup>3</sup> Data Products .....	1
1.3 Links to More In-Depth Technical Documentation.....	2
1.4 Improvements in Reporting Introduced with FAF <sup>3</sup> .....	3
2 FAF <sup>3</sup> Geography, Commodity and Modal Classes .....	4
2.1 Geography.....	4
2.2 Commodity Classes .....	5
2.3 Transportation Modes .....	6
3. The Flow Matrix Construction Process .....	7
3.1 Overview.....	7
3.2 Modeling to Enhance CFS In-Scope Flows.....	8
3.2.1 CFS Data Gaps and Data Tables.....	8
3.2.2 Log-Linear Modeling of Missing Cell Values.....	10
3.3 Data and Modeling of Non-CFS Flows .....	13
3.3.1 Domestic Flows .....	13
3.3.2 Import and Export Flows .....	22
References.....	24
Appendix A: Differences in the FAF <sup>3</sup> and FAF <sup>2</sup> Freight Flow Matrices .....	26





## 1. Introduction

### 1.1 Purpose of This Document

This document provides an overview of how the origin-destination-commodity-mode (ODCM) annual freight flows matrix developed under the Freight Analysis Framework, Version 3 (FAF<sup>3</sup>) program. FAF<sup>3</sup> is a Federal Highway Administration (FHWA) funded and managed data and analysis program that provides estimates of the total volumes of freight moved into, out of and within the United States, between individual states, major metropolitan areas, sub-state regions, and major international gateways. The FAF<sup>3</sup> database is constructed by Oak Ridge National Laboratory (ORNL). Staff at MacroSys contributed to the development of a number of industrial sector-specific commodity flow estimates. Staff at Battelle Memorial Institute, and at IHS Global Insight have also developed FAF<sup>3</sup> data products that derive from the 2007 freight flow matrices described in this report.

*This present document is devoted to describing how the base year, 2007 annual tonnage and dollar valued flows are estimated in the FAF<sup>3</sup> ODCM matrix.* The document is labeled an overview because a detailed description of the flow matrix building procedure is very lengthy. This present document should suffice the majority of readers interested in knowing the basics of where the flow estimates come from. More detailed descriptions of specific flow estimation components are provided for those wishing to go further into the process. Separate FAF<sup>3</sup> documents also describe how these flows are projected into future years, and how these base and forecast year flows are then converted into vehicle/vessel traffic volumes and assigned to (i.e. routed over) individual links and routes within the US national highway, rail and waterway networks.

### 1.2 FAF<sup>3</sup> Data Products

FAF<sup>3</sup> data products are the result of merging datasets from a large number of different sources. The principal data products developed under the FAF<sup>3</sup> umbrella are the following:

- A set of annual freight flow matrices, reported in annual tonnages and annual dollar value of goods transported, for calendar year 2007 for the United States,
- Based on these base year flow estimates, a set of forecast year freight flow matrices, projected out to calendar year 2040,
- A set of annual freight tonnage and vehicle/vessel movement volumes assigned to specific links and routes over the United States multimodal truck-rail-waterways transportation network, based on these base year 2007 and forecast year 2040 flow estimates.

Based on these estimated freight flows and their network assignments, a set of annual freight tonnage, dollar value, and ton-mileage statistics, broken down by mode of transport and commodity class are also developed.

Figure 1.1 show the functional linkage between these various FAF<sup>3</sup> data products, starting with the creation of the calendar year 2007 FAF<sup>3</sup> national freight flows matrix. Also shown in Figure 1.1 is a new data product coming out of the FAF<sup>3</sup> effort. This is not a data set per se, but an on-line, web-based tool for extracting data elements from the FAF<sup>3</sup> database and constructing useful data tables on a regional, modal and/or commodity specific basis.

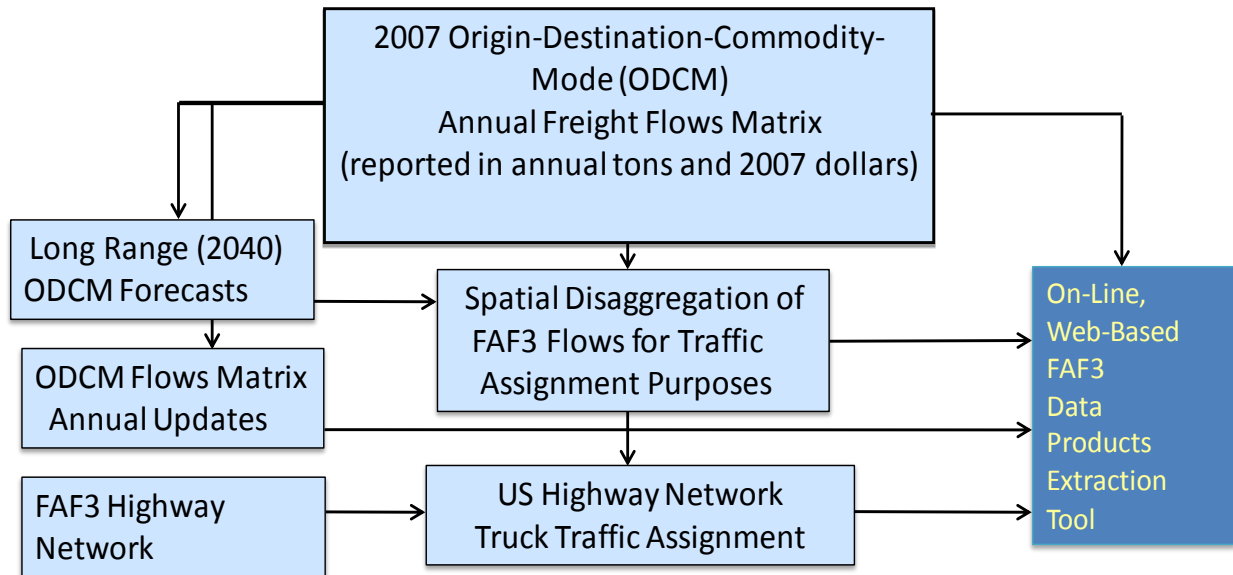

**Figure 1.1 Principal FAF<sup>3</sup> Data Products**

Freight origin-to-destination (O-D) movements are estimated in FAF<sup>3</sup> on both an annual tonnage and annual dollar value basis, for calendar year 2007. These estimates are then used as the basis for developing both annual *provisional* updates and as the starting point for a set of longer-range freight movement forecasts, reported at five year intervals from 2015 out to year 2040. The principal dimensions of these *FAF<sup>3</sup> Freight Flow Matrices* are:

- Shipment origination region (O),
- Shipment destination region (D),
- The class of commodity being transported (C), and
- The mode of transportation used (M).

The FAF<sup>3</sup> freight flows matrix is made up of 131 Origin (O) x 131 Destination (D) x 43 Commodity Class (C) x 8 Modal Category (M) data cells, for each of 2 reporting metrics, annual tons and annual dollar values.

### 1.3 Links to Technical Documentation

FAF<sup>3</sup> is the third database of its kind, with the FAF<sup>1</sup> database providing similar freight data products based on calendar year 1997 data, and FAF<sup>2</sup> providing freight data products based on calendar year 2002 data. Since the very first FAF effort, a number of changes in both data

products and in the sources of the data used to produce them have taken place. A description these earlier data products, along with the FAF<sup>3</sup> data products, can be found at the following FHWA website:

[http://www.ops.fhwa.dot.gov/freight/freight\\_analysis/faf/index.htm](http://www.ops.fhwa.dot.gov/freight/freight_analysis/faf/index.htm)

This site also guides the user to the *FAF<sup>3</sup> on-line Data Extraction Tool*, which can also be accessed directly at:

<http://cta-gis.ornl.gov/faf/>

At this site a user can customize and download a variety of freight flow tables directly from the FAF<sup>3</sup> database. Interactive links are also provided to FAF<sup>3</sup> Data Documentation, Data Summary, and maps.. Users can also download the entire FAF<sup>3</sup> 2007 regional database in either Microsoft Access 2003 (125MB) or in CSV (100MB) format.

#### **1.4 Improvements in Reporting Introduced with FAF<sup>3</sup>**

With this latest version of the FAF a number of improvements to the commodity flow matrix have been possible over previous versions. These include:

- A roughly doubling of the number of U.S. shipping establishments sampled as part of the 2007 U.S. Commodity Flow Survey (from some 50,000 establishments in 2002, to approximately 100,000 establishments surveyed in 2007);<sup>1</sup>
- The use of PIERS data to support improved estimates of the internal to the U.S. allocations of imports and exports to FAF domestic zones of freight origination (for U.S. exports) and destinations (for U.S. imports);
- Incorporation of additional federal datasets within an improved FAF<sup>3</sup> log-linear modeling/iterative proportional fitting algorithm, as well as the development of the Out-of-Scope estimates;
- Greater use of U.S. inter-industry input-output ('use' and 'make') coefficients in the development of the FAF<sup>3</sup> out-of-scope (to the 2007 CFS) commodity flow estimates;
- FAF<sup>3</sup> provides an O-D specific treatment of natural gas products, which were evaluated only at the level of national or broad regional activity totals in FAF<sup>2</sup>; and
- The ability to access FAF<sup>3</sup> data products via a user friendly web-based data set construction and download tool (cf. Section 1.3 above).

---

<sup>1</sup> For changes in the CFS between 2002 and 2007 see the following Bureau of Transportation Statistics website: [http://www.bts.gov/help/commodity\\_flow\\_survey.html#diff\\_2007\\_2002](http://www.bts.gov/help/commodity_flow_survey.html#diff_2007_2002)

## 2. FAF<sup>3</sup> Geography, Commodity and Modal Classes

### 2.1 Geography

The 2007 CFS commodity flow tables are based on a revised geography that contains 11 additional traffic analysis regions, for a total of 123 domestic regions in all. FAF<sup>3</sup> uses the same geography. Figure 2.1 shows the boundaries of the 123 domestic FAF<sup>3</sup> flow analysis regions, also referred to as FAF<sup>3</sup> analysis zones.

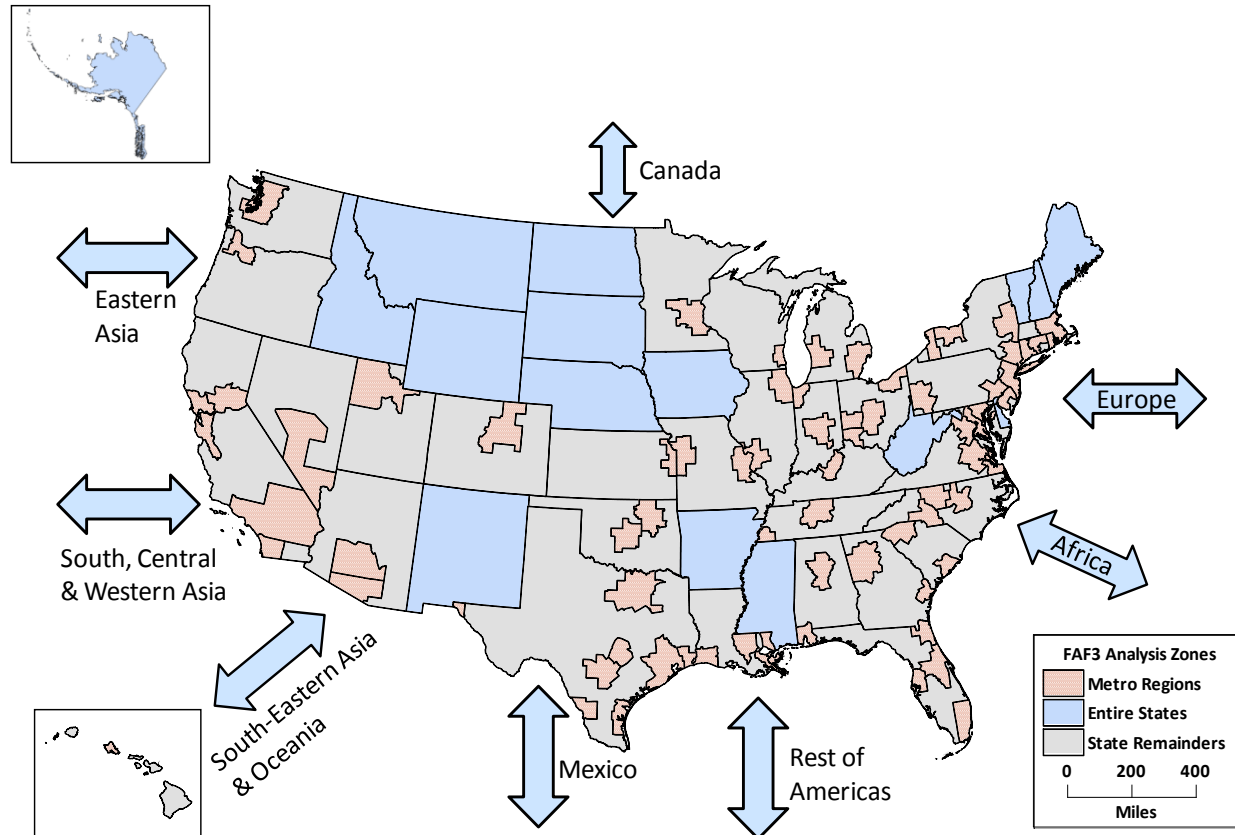

**Figure 2.1 FAF<sup>3</sup> Geography**

Three subsets of regions are highlighted: 74 metropolitan area determined regions, 33 regions made up of state remainders, representing a state's territory outside these metropolitan regions, and 16 regions identified as entire states, within which no FAF<sup>3</sup> metropolitan regions exist.

Note that metropolitan regions do not cross State boundaries: so that the Chicago, Kansas City, Philadelphia, and St. Louis metros are split into two state-specific FAF<sup>3</sup> regions, while the New York and Washington metropolitan areas are split into three distinct zones. To avoid crossing State boundaries the metropolitan areas of Atlanta (GA), Boston (MA), Charlotte (NC), Louisville (KY), Memphis (TN), Minneapolis-St. Paul (MN), Portland (OR), Providence (RI), Sacramento (CA), and Virginia Beach (VA) are each defined by the state in which most of the

metro areas' population resides and economic activity takes place. Also shown in Figure 2.1 are the 8 world regions that act as the origination and destination points for U.S. exported and imported freight. In addition to flows between the U.S. and Canada and the U.S. and Mexico, flows between the U.S. and the remaining six foreign FAF<sup>3</sup> regions are based on an allocation of countries to their respective United Nations geographic region.<sup>2</sup>

## 2.2 Commodity Classes

FAF3 reports annual tonnage and dollar valued freight flows using the same 43 2-digit Standard Classification of Transported Goods (SCTG) classes used by the 2007 U.S. Commodity Flow Survey (CFS).

**Table 2.1 FAF<sup>3</sup> Commodity Classes**

SCTG	Commodity	SCTG	Commodity	SCTG	Commodity
<b>01</b>	Live animals/fish	<b>15</b>	Coal	<b>29</b>	Printed products
<b>02</b>	Cereal grains	<b>16</b>	Crude petroleum	<b>30</b>	Textiles/leather
<b>03</b>	Other agricultural products.	<b>17</b>	Gasoline	<b>31</b>	Nonmetal mineral products
<b>04</b>	Animal feed	<b>18</b>	Fuel oils	<b>32</b>	Base metals
<b>05</b>	Meat/seafood	<b>19</b>	Coal-n.e.c.	<b>33</b>	Articles-base metal
<b>06</b>	Milled grain prods.	<b>20</b>	Basic chemicals	<b>34</b>	Machinery
<b>07</b>	Other foodstuffs	<b>21</b>	Pharmaceuticals	<b>35</b>	Electronics
<b>08</b>	Alcoholic beverages	<b>22</b>	Fertilizers	<b>36</b>	Motorized vehicles
<b>09</b>	Tobacco prods.	<b>23</b>	Chemical prods.	<b>37</b>	Transport equipment
<b>10</b>	Building stone	<b>24</b>	Plastics/rubber	<b>38</b>	Precision instruments
<b>11</b>	Natural sands	<b>25</b>	Logs	<b>39</b>	Furniture
<b>12</b>	Gravel	<b>26</b>	Wood products	<b>40</b>	Misc. mfg. products.
<b>13</b>	Nonmetallic minerals	<b>27</b>	Newsprint/paper	<b>41</b>	Waste/scrap
<b>14</b>	Metallic ores	<b>28</b>	Paper articles	<b>43</b>	Mixed freight
				<b>99</b>	Commodity unknown

<sup>2</sup> See <http://unstats.un.org/unsd/methods/m49/m49regin.htm> for these country-to-region allocations.

## 2.3 Transportation Modes

FAF<sup>3</sup> flows are also broken down by 8` modes of transportation. Table 2.2 lists these mode and commodity classes.

The “multiple modes and mail” category includes truck-rail, truck-water, and rail-water intermodal shipments involving one or more end-to-end transfers of cargo between two different modes. Detailed SCTG code definitions can be downloaded at either of the following Census and Bureau of Transportation Statistics websites:

<http://www.census.gov/svsd/www/cfsdat/2002data/cfs021200.pdf>

[http://www.bts.gov/publications/commodity\\_flow\\_survey/survey\\_materials/pdf/sctg\\_booklet.pdf](http://www.bts.gov/publications/commodity_flow_survey/survey_materials/pdf/sctg_booklet.pdf)

Appendix A describes how these CFS-based regional, modal, and commodity class definitions differ from those used by FAF<sup>2</sup>.

**Table 2.2 FAF<sup>3</sup> Mode Classes**

Mode Identification	Mode Name	Mode Description
1	Truck	Includes private and for-hire truck. Private trucks are owned or operated by shippers, and exclude personal use vehicles hauling over-the-counter purchases from retail establishments.
2	Rail	Any common carrier or private railroad.
3	Water	Includes shallow draft, deep draft and Great Lakes shipments.
4	Air (includes truck-air)	Includes shipments typically weighing more than 100 pounds that move by air or a combination of truck and air in commercial or private aircraft. Includes air freight and air express. Shipments typically weighing 100 pounds or less are classified with <i>Multiple Modes and Mail</i>
5	Multiple Modes and Mail	Includes shipments by multiple modes and by parcel delivery services, U.S. Postal Service, or couriers. This category is not limited to containerized or trailer-on-flatcar shipments.
6	Pipeline	Includes flows from offshore wells to land, which are counted as water moves by the U.S. Army Corps of Engineers.
7	Other and Unknown	Includes flyaway aircraft, vessels, and vehicles moving under their own power from the manufacturer to a customer and not carrying any freight, unknown, and miscellaneous other modes of transport.
8	No Domestic Mode	A ‘No Domestic Mode’ category is used to capture petroleum imports that go directly from foreign, inbound ships to an on-shore US refinery. This is done to ensure a proper accounting when foreign and domestic flows are summed, while avoiding assigning flows to the domestic transportation network that do not use it.



### 3. The Flow Matrix Construction Process

#### 3.1 Overview

The FAF<sup>3</sup> modeling process draws from many data sources but the most important is the U.S. Commodity Flow Survey.(CFS). Figure 3.1 shows the principal types of data used to construct the FAF<sup>3</sup> ODCM freight flows matrix. This matrix construction process begins with the data reported by the 2007 CFS<sup>3</sup>, adopting both the CFS definitions for the 123 internal to the U.S. freight analysis zones and the same 43 SCTG 2-digit commodity classes, but using a modification of CFS modal definitions. Each of these three data dimensions is elaborated on below.

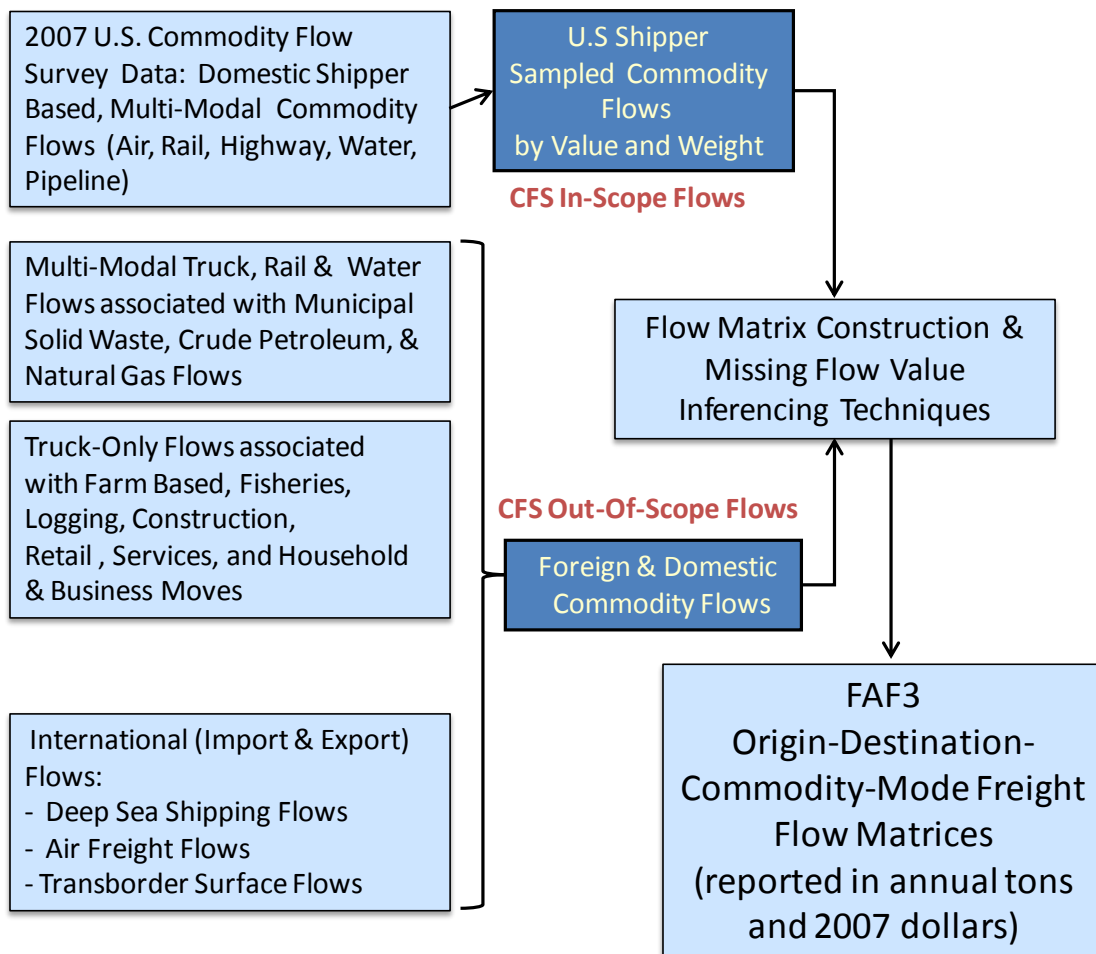

**Figure 3.1 Overview of the FAF<sup>3</sup> Freight Flow Matrix Construction Process**

<sup>3</sup>For the details of how the 2007 CFS survey methodology, and for on-line access to the public domain CFS data products, go to: [http://www.bts.gov/publications/commodity\\_flow\\_survey/](http://www.bts.gov/publications/commodity_flow_survey/)

The CFS itself is conducted every 5 years as part of the U.S. Economic Census, with major funding for the survey provided by the Bureau of Transportation Statistics (BTS). Data are collected on all shipments from the surveyed establishment for an entire week in each of the four quarters of the census year. In 2007, about twice as many establishment samples were recorded as in 2002.

The CFS represents the best basis for FAF construction because it provides shipper sampled, and subsequently expanded estimates of both tons shipped and dollar value trades within and between all US regions for all modes of freight transportation. However, the CFS has a number of well researched weaknesses that require considerable additional effort in order to construct a complete accounting of freight movements within the United States (see TRB, 2006). First, the CFS does not report imports, while CFS reporting of export flows is also subject to data quality issues resulting from limited sample size. Second, the CFS also either does not collect data from the following freight generating and receiving industries, or collects insufficient data to cover the industries in a comprehensive manner:

- Truck, rail and pipeline flows of crude petroleum, and natural gas,
- Truck freight shipments associated with farm-based, fishery, logging, construction, retail, services, municipal solid waste, and household and business moves, and.
- Imported and exported goods transported by ship, air, and trans-border land (truck, rail) modes.

In FAF<sup>3</sup> these industries produce what are referred to in Figure 3.1 as Non-CFS or Out-Of-Scope (OOS) to the CFS freight flows. Their estimation requires a good deal of data collection and integration into the larger flow matrix generation process. The data sources for these OOS flows are for the most part derived from freight carrier reported data sources, in some cases requiring the use of secondary or indirect data sources, such as location specific measures of industrial activity, employment or population, to allocate flows to specific geographic regions. These OOS flows represent some 32% of all U.S. freight movements measured on an annual tonnage basis. Developing OOS flow estimates represents a considerable effort, with different commodity classes requiring very different, typically multi-step treatments: including the use of both spatial and commodity class “crosswalks” that convert mode and industry class specific estimates from their native coding categories into FAF<sup>3</sup> regional and commodity class breakdowns.

## **3.2 Modeling to Enhance CFS In-Scope Flows**

### **3.2.1 CFS Data Gaps and Data Tables**

The 2007 CFS is a large and very sparse matrix of annual tonnage and dollar valued freight shipment volumes, with many individual cells assigned a value of value of zero tons and zero dollars of freight shipped during the calendar year. The complete set of 2007 CFS data products

includes a large number of different data matrices.<sup>4</sup> This includes the most detailed of the published matrices, Table CF0700A25, which reports annual tons, dollar values, and also ton-miles shipped by state of origin, state of destination, mode and 2-digit commodity class.<sup>5</sup> Although these are the four flow dimensions needed for the FAF this matrix contains many data gaps, and reports only state-to-state shipment totals that need to be assigned in some manner to FAF region-to-region flows. Fortunately, other CFS tables provide 1, 2 and 3 dimensional looks at this same data, including marginal totals at the FAF regional level that do not suffer to the same extent from data suppression. Without going through the contents of each CFS data table in turn, these gaps in the 2007 CFS coverage can be summarized as follows:

- Annual O-D commodity flow estimates exist but some are missing either a modal or commodity breakdown, or both,
- Modal share estimates exist but lack the geographic and/or commodity detail required of the FAF<sup>3</sup> flows matrix, and
- Data on shipment lengths exists, by mode and/or commodity, but with little or no linkage to either State or FAF<sup>3</sup> regional O-D geography.

In many instances data is missing or suppressed at the 2- or 3-, as well as 4-dimensional level of flow resolution. That is, we have a flow matrix that contains a variety of levels of coverage, with many data gaps needing to be filled.

While many of these zero valued cells are accurate, CFS sample size limitations may also be responsible for missing some of these flows at the origin-destination-commodity-mode level of resolution sought by the FAF; or for creating flow estimates that have such high variability (sampling error) that the US Census Bureau chose to suppress their values. Where such suppression occurs in the CFS a cell value has been replaced by the letter ‘S’. In some cases ‘S’ reported cells may represent quite large freight flows in the real world, because a large coefficient of variation does not necessarily mean that we have only small O-D flows to deal with. For FAF reporting purposes an estimate is desired for these suppressed cell values, and also for any zero valued cells where limited CFS sampling has failed to produce a positive flow estimate, but where freight is likely being shipped.<sup>6</sup> The question the FAF has to answer is not

---

<sup>4</sup> [http://www.bts.gov/publications/commodity\\_flow\\_survey/](http://www.bts.gov/publications/commodity_flow_survey/) Click on “Interactive tables.”

<sup>5</sup> <http://www.census.gov/svsd/www/02CFSdata.html>

<sup>6</sup>Reporting of individual CFS cell values may also be suppressed to avoid disclosing information about an individual company’s activity. For the CFS, the primary method of disclosure avoidance is Noise Infusion: Noise infusion is a method of disclosure avoidance in which values for each shipment are perturbed prior to tabulation by applying a random noise multiplier. Disclosure protection is accomplished in a manner that causes the vast majority of cell values to be perturbed by at most a few percentage points. In certain circumstances, some individual cells may be suppressed on a case by case basis for additional disclosure avoidance purposes. Such cell values have their flow values replaced by the letter ‘D’ in published CFS tables.

[http://www.bts.gov/publications/commodity\\_flow\\_survey/def\\_terms/index.html#samplingerror](http://www.bts.gov/publications/commodity_flow_survey/def_terms/index.html#samplingerror)

only what size each of these flows should be, but also, which of the many zero valued cells ought to contain a positive flow at all.

### 3.2.2 Log-Linear Modeling of Missing Cell Values

The procedure used for estimating these missing cell values is shown in Figure 3.2. This figure is a high level treatment of the problem. The following description provides an overview of the major data steps in this data modeling process.

In FAF<sup>3</sup>, missing 2007 CFS cell values are first of all estimated using a six-dimensional log-linear model. The first four of these dimensions are the above-defined FAF origin region (O), FAF destination region (D), FAF commodity class (C) and FAF mode of transport (M). To this are added two additional dimensions:

- A ‘freight metrics’ dimension, U, defined by the two classes of metric reported by the CFS, i.e. tonnage ( $u = 1$ ) and dollar value of freight moved ( $u = 2$ ); and
- A data source’ dimension, S, that captures four different classes (= sources) of freight flow estimates, i.e. the 2007 CFS ( $s = 1$ ), the 2002 CFS ( $s = 2$ ), the 2007 Railcar Waybill dataset ( $s = 3$ ), and the 2007 Waterborne Commerce dataset ( $s = 4$ ).

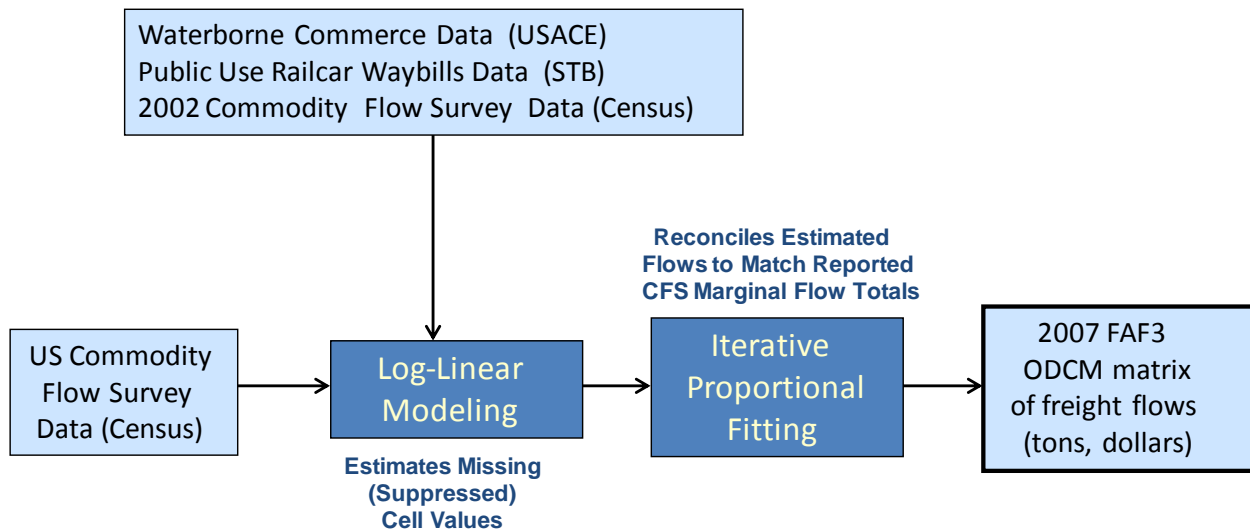

**Figure 3.2 Estimation of Missing Cell Values in the 2007 US Commodity Flow Survey**

Zero valued cells in the 2007 CFS can be categorized as either “structural” or sampling zeros. For example, truck commodity flows between Hawaii and mainland US regions is an obvious structural zero. Sampling zeros are divisible two types:

1. Cells where no sample data was obtained by the 2007 CFS, but flows may exist; and

2. Cells where the volume of freight sampled was so small that it fell below the CFS reporting threshold, i.e. below 500 tons, or below half a million dollars, and was therefore rounded down to '0' in the CFS published tables.

In particular, a large number of CFS cells have had their value suppressed, for either confidentiality or statistical robustness reasons. For example, cell values are suppressed reported in the 2007 CFS if the coefficient of variation associated with the cell estimate exceeds 50%. The method used for estimating these suppressed, and therefore, missing cells values in the CFS flow matrix is a combination of log-linear modeling (LLM) and iterative proportional fitting (IPF). This LLM/IPF procedure was selected because it has the following characteristics:

1. It makes extensive use of existing data within the matrix in the estimation of missing cell values,
2. It offers the ability to fill in missing cell values while maintaining reported marginal flow totals and observed cell values across all dimensions of the matrix,
3. It has the ability to handle missing values at multiple levels of data aggregation, and
4. It offers the ability to bring different, including non-CFS sources of flow estimates, into the solution, including completely new one, two, and three-dimensional data tables, as needed.

This last characteristic has been exploited extensively for the first time in developing the FAF<sup>3</sup> freight flows matrix, and represents a major enhancement to the modeling process used in the previous flow matrix generation process. Specifically, flows reported by two carrier-reported, mode specific datasets are used to help the FAF<sup>3</sup> flows matrix capture potentially missing or under-represented flow estimates. These are:

1. Calendar year 2007 annual rail flow volumes (tonnages) reported in the Surface Transportation Board's (STB) public use railcar waybills<sup>7</sup>, and
2. Calendar year 2007 annual flow volumes (tonnages) reported in the US Army Corps of Engineers Waterborne commerce dataset.<sup>8</sup>

In addition, data from the 2002 CFS is also used to look for potentially positive, but zero valued (i.e. sampling zero) flow cells.

In practice, each of these data sources is treated as a component of a sixth dimension in an expanded FAF<sup>3</sup> freight flows matrix.<sup>9</sup> Where a positive cell value is reported in any of these data

---

<sup>7</sup> Accessible via [http://www.stb.dot.gov/stb/industry/econ\\_waybill.html](http://www.stb.dot.gov/stb/industry/econ_waybill.html)

<sup>8</sup> Accessible via <http://www.iwr.usace.army.mil/ndc/data/data1.htm>

<sup>9</sup> By housing these alternative modal data sources within a single dimension of the matrix in this manner we are also allowing, without loss of generality, for the application of more sophisticated across the board CFS + non-CFS weighting schemes in the future.

sources, these cells are subsequently assigned a positive value by the LLM/IPF routine, from which a maximum likelihood estimate of that flow's volume is estimated.

The complete FAF<sup>3</sup> commodity flow model, referred to as the “Log-Linear Model” in Figure 3.2, has the following form:

$$\begin{aligned} \text{Ln}(F^{\text{ODCMUS}}) = & \lambda_0 + \lambda^{\text{O}} + \lambda^{\text{D}} + \lambda^{\text{M}} + \lambda^{\text{C}} + \lambda^{\text{U}} + \lambda^{\text{S}} + \lambda_j^{\text{OD}} + \lambda^{\text{OC}} + \lambda^{\text{OM}} + \lambda^{\text{OU}} + \lambda^{\text{DC}} + \\ & \lambda^{\text{DM}} + \lambda^{\text{DU}} + \lambda^{\text{CM}} + \lambda^{\text{CU}} + \lambda^{\text{MU}} + \lambda^{\text{OS}} + \lambda^{\text{DS}} + \lambda^{\text{CS}} + \lambda^{\text{MS}} + \lambda^{\text{US}} + \lambda^{\text{ODC}} + \lambda^{\text{ODM}} + \lambda^{\text{ODU}} + \lambda^{\text{OCM}} \\ & + \lambda^{\text{OCU}} + \lambda^{\text{OMU}} + \lambda^{\text{DCM}} + \lambda^{\text{DCU}} + \lambda^{\text{DMU}} + \lambda^{\text{CMU}} + \lambda^{\text{ODS}} + \lambda^{\text{OCS}} + \lambda^{\text{OMS}} + \lambda^{\text{OUS}} + \lambda^{\text{DCS}} + \lambda^{\text{DMS}} + \\ & \lambda^{\text{DUS}} + \lambda^{\text{CMS}} + \lambda^{\text{CUS}} + \lambda^{\text{MUS}} + \lambda^{\text{ODCM}} + \lambda^{\text{ODCU}} + \lambda^{\text{ODCS}} + \lambda^{\text{ODMU}} + \lambda^{\text{ODMS}} + \lambda^{\text{ODUS}} + \lambda^{\text{OCMU}} + \lambda^{\text{OCMS}} \\ & + \lambda^{\text{OCUS}} + \lambda^{\text{OMUS}} + \lambda^{\text{DCMU}} + \lambda^{\text{DCMS}} + \lambda^{\text{DCUS}} + \lambda^{\text{DMUS}} + \lambda^{\text{CMUS}} + \lambda^{\text{ODCMU}} + \lambda^{\text{ODCMS}} + \lambda^{\text{ODMUS}} + \\ & \lambda^{\text{ODCUS}} + \lambda^{\text{OCMUS}} + \lambda^{\text{DCMUS}} + \lambda^{\text{ODCMUS}} \end{aligned}$$

where  $\text{Ln}(F^{\text{ODCMUS}})$  is the model estimated natural log (log to the base e) annual volume of commodity ‘C’ moved by mode ‘M’ between FAF<sup>3</sup> origin zone ‘O’ and FAF<sup>3</sup> destination zone ‘D’ in 2007, measured in units ‘U’ ( i.e U=1 for annual tons, U=2 for annual dollar value of the freight moved), and found in data source ‘S’ (e.g. S = 1 for CFS 2007, S=2 for CFS 2002, S= 3 for 2007 Railcar Waybills, and S = 4 for 2007 Waterborne Commerce).

The  $\lambda$ 's represent the model parameters to be estimated, often termed the (natural log of the) *effects* of the different dimensions, or combinations of dimensions, on the resulting flow estimates. For example,  $\lambda^{\text{OM}}$  represents the effect of shipment origin O and mode M,  $\lambda^{\text{ODCM}}$  represents a four-way, O,D,C,M interaction effect, and  $\lambda_0$  represents the grand mean of all these effects. Parameters representing all possible levels and combinations of the matrix dimensions O,D,C,M,U and S are used to fit the data to what is usually termed a *saturated* model that tries to get the most out of the statistical relationships represented by the data sources. This equation is translated into an additive, natural log form for solution (i.e. for computational) purposes. In practice, many of the  $\lambda$ 's are set to a value of 0.0. For example, since both the 2007 railcar waybill and waterborne commerce flows are only reported in tons, all dollar valued  $\lambda$ 's associated with these two data sources = 0.0 and play no further part in the estimation process.

### 3.2.3 Iterative Proportional Fitting (IPF) to CFS Marginal Totals

Once all of the log-linear model's  $\lambda$  *effects* have been computed, they are used to generate a positive value of each zero valued flow cell in the original 2007 CFS commodity flow matrix. In each case, where a zero valued cell is found it is replaced with an estimate based on the above multiplicative log-linear model. Three additional steps are then taken:

- 1) Cells considered to be structural zeros are returned to a value of 0.0.
- 2) To further assist with filling in of missing CFS cell values, an additional dataset was provided by the U.S. Bureau of the Census. This is a matrix containing the number of establishments



sampled within each ODCM cell in the matrix, i.e. a set of raw sample responses. If one or more positive responses are identified for a specific cell, then this is taken to imply the presence of some freight movement activity, and it is therefore treated as a sampling zero for the purpose of cell value estimation.

3) A third modification to process then involves the removal of unreasonable dollar per ton estimates caused by biased or limited sampling, in which either the tonnage or the dollar value allocated to a particular cell by the log-linear/IPF modeling process creates a dollar-per-ton ratio that exceeds expected values for the commodity class in question by a significant amount. To prevent this from occurring, a check is made every ten iterations of the IPF to look for such outliers. If one or more are found, an adjustment is made to either the tonnage or dollar value in such a cell and the iterative process re-commenced.

The resulting matrix (now with no missing values) is then adjusted through IPF to comply with known control totals from numerous CFS marginal tables. It is important to note here that after the full LLM/IPF procedure is completed, no 2007 CFS ODCM or higher (3 or 2 dimensional) marginal cell value has been changed if it contained a positive flow value to begin with. Only potentially missing valued cells (of which there are many) are altered by the process.

### 3.3 Data and Modeling of Non-CFS (Out-of-Scope) Flows

#### 3.3.1 Domestic Flows

U.S. freight shipping establishments in the following industrial sectors were not surveyed as part of the 2007, or previous, US Commodity Flow Surveys. The following out-of-scope (OOS) industries therefore had to be assigned commodity and mode specific O-D flows using other methods:

1. Farm Based	6. Retail
2. Fishery	7. Household and Business Moves
3. Logging	8. Municipal Solid Waste
4. Construction	9. Crude Petroleum
5. Services	10. Natural Gas Products

OOS flows were estimated using commodity specific datasets and different computational methods for each industrial class. Where an industrial sector produces O-D flows in more than one commodity class, data from national inter-industry input-output “use” and “make” tables was used to determine how much freight each sector contributes to a specific set of SCTG 2-digit commodity flows. State and county level data on volume of production, industrial or commodity specific sector sales, or industrial sector employment is then used to allocate flows between origins and destinations. Spatial allocation formulas are then used to produce O-D flow volumes. Where truck movements were concerned this occurred in one of two ways. Either county level origin and destination activity totals were determined, and then a spatial interaction model was applied to these county productions and attractions, with subsequent aggregation of inter-county

flows back up to FAF<sup>3</sup> region-to-region flow totals. Or county Os and Ds are first of all estimated and aggregated to their FAF<sup>3</sup> regional supply and demand totals. These regional totals are then used to estimate O-to-D flows directly at the FAF<sup>3</sup> region-to-region level.

The specific form of spatial interaction model used also varied by commodity class. Either a distance decay coefficient is calibrated against an empirically derived average shipping distance, or a simple allocation is made based on market potentials (i.e. on the relative size of a county's or region's demand for a specific commodity). County-level spatial interaction modeling here allows for cross-county flows to be captured that are also cross-FAF<sup>3</sup> adjacent regional flows. Use of regional O and D shipment totals prior to spatial interaction modeling occurred where data sources proved more reliable at this less detailed level or geography.

Figure 3.3 shows the general idea. In practice, each industrial sector has its own data gaps and idiosyncrasies that needed to be dealt with.

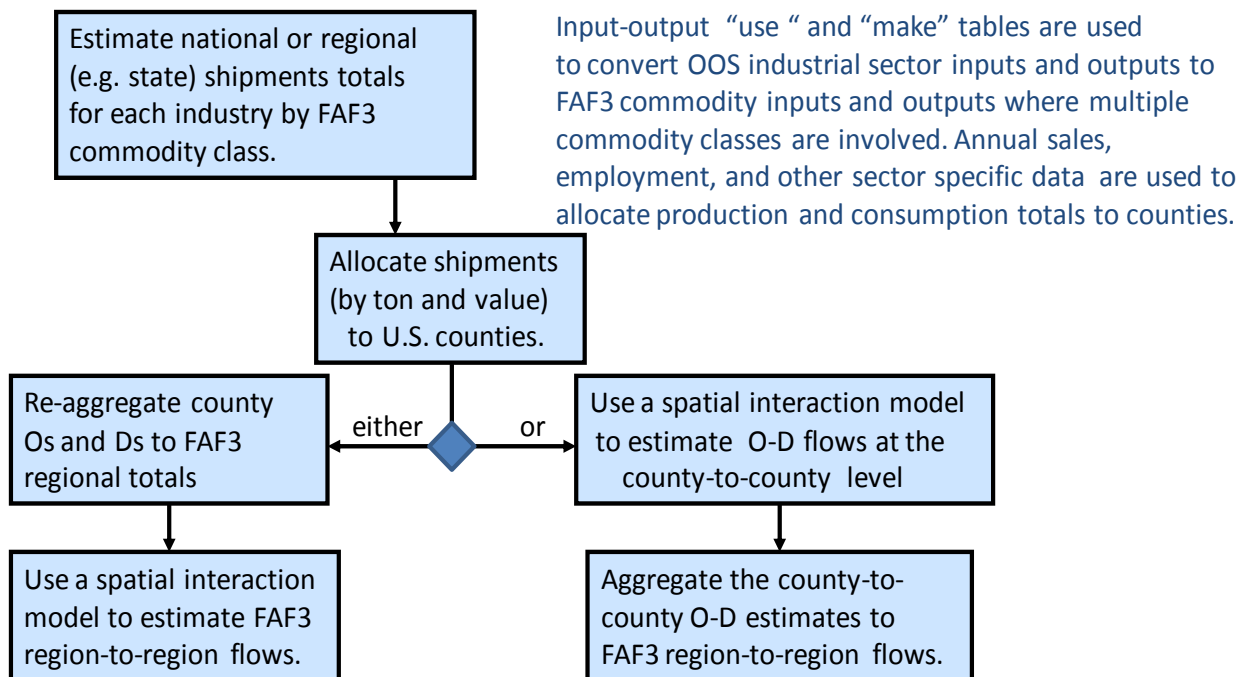

Note: Data modeling details vary a good deal by industrial sector/commodity class

### Figure 3.3 Four Step Process for Generating OOS Truck Freight Flows

The following sections focus on summarizing the datasets used to produce the FAF<sup>3</sup> flow estimates. For greater detail on estimation methods, the reader should consult FAF<sup>3</sup> industry sector-specific write-ups.

### ***Farm Based Flows***

Farm-based agricultural shipments represent one of the most significant out-of-scope areas for CFS. These shipments are almost entirely moved by truck. The vast majority of these shipments represent farm-to-storage elevator (e.g., grains) or farm-to-distribution/processing center (e.g., fruit, livestock) trips, at which point further transportation of these products is captured as part of the CFS sample frame. At the fully national level, the total tonnage of farm-based agricultural shipments constitutes nearly 7% of the 2007 total tonnage moved within the nation, and over 9% of all truck tons shipped. County and state level data published by in U.S. Department of Agriculture's (USDA) 2007 *Census of Agriculture* and the 2008 *Agricultural Statistics* were used to generate FAF<sup>3</sup> tons and dollars shipped estimates, supplemented with data from several of USDA's *Statistical Bulletins*.

The dollar value of these farm originating agricultural products were estimated using information obtained from the 2007 *Census of Agriculture* and related publications. Specifically, data provided under the category of "Market value of agricultural products sold"<sup>10</sup> was used as an estimate for total farm-based agricultural shipments. The estimation of tonnages for these out-of-scope shipments was less straightforward. Commodity statistics published in the USDA's 2007 *Census of Agriculture* use a variety of commodity specific units of measurement (e.g., pounds, bushels, hundredweight, barrels, tons, etc). In some cases, different conversion factors, all based on information obtained from *Agriculture Statistics 2008*, were also needed for different commodities using the same basic unit of measurement. For example, the approximate net weight for a bushel of wheat is 60 pounds, while a bushel of husked corn on the ear weighs 70 pounds, and shelled corn weighs in at 56 pounds per bushel on the average. Following these unit conversions, each farm-based agricultural commodity is then placed within its 2-digit SCTG commodity class.

Where a State is divided into more than one FAF<sup>3</sup> region, USDA county level data was used and subsequently re-aggregated to FAF<sup>3</sup> regional totals. This was done after filling gaps in this county-specific data, by using acreages devoted to a specific crop-growing activity as a surrogate for gaps in direct reporting of crop yields. O-D flows are then estimated, first by summing these county originations to their FAF<sup>3</sup> regional totals, then sharing these totals to FAF<sup>3</sup> destination regions on the basis of a) truck trip length distributions reported by the 2002 VIUS, and b) using the volumes of agricultural commodity originations reported by the 2007 CFS to allocate these flows. That is, these CFS originations (from the distribution centers, grain elevators, processing centers, etc. located within a CFS region) constitute the first non-farm stop in the agricultural product's supply chain. Hence they represent a good surrogate for the destinations of farm-based shipments. Separate allocations are made on the basis of tons shipped and dollar valued trades.

---

<sup>10</sup> The "market value of agricultural products sold" category represents the value of products sold which combines total sales not under production contract and total sales under production contract. It is equivalent to total sales. See Appendix B, General Explanation and Census of Agriculture Report Form, in the 2007 *Census of Agriculture* report for further explanation ([http://www.agcensus.usda.gov/Publications/2007/Full\\_Report/Volume\\_1,\\_Chapter\\_1\\_US/usappxb.pdf](http://www.agcensus.usda.gov/Publications/2007/Full_Report/Volume_1,_Chapter_1_US/usappxb.pdf))

As a result of this process, the annual tons and dollar valued flows between any two FAF<sup>3</sup> regions are consistent with both VIUS truck trip length distributions for a specific FAF<sup>3</sup> freight originating region and commodity class, and also create a consistency between OOS farm-based flows and the non-farm based agricultural commodity flows reported in the 2007 CFS.

### ***Construction Industry Flows***

Shipments originating from activities in the construction sector, including companies or establishments engaged in construction of residential and non-residential buildings, utility systems, roadways and bridges, and from specific trade contractors, are not in-scope for the CFS. It is estimated that this industry transported just under 1.08 billion tons of freight over the course of 2007, valued at \$905.7 million. However, putting a dollar value on such freight is not straight-forward. The primary commodity shipped was debris (included in SCTG 41 under Waste and Scrap), for which the value would be relatively small unless recyclable materials are separated and sold. An estimate of the amount of debris generated by the construction industry was developed based on publications by the U.S. Environmental Protection Agency (EPA) publications,<sup>11</sup> the National Demolition Association, Construction Materials Recycling Association, and Gershman, Brickner & Bratton, Inc. Similar dollar to ton conversions for other commodity classes are drawn from the CFS or other industry specific sources.

Data on shipment distances for the industry are limited at best for 2007, and in FAF<sup>3</sup> all of these shipments are assumed to be short distance truck movements, most occurring within a single county, and all within the same FAF<sup>3</sup> zone. Shipment volumes were assigned to FAF<sup>3</sup> regions using sales data from the 2007 Economic Census (EC) where available, and using a combination of 2007 county level employment data from the Census Bureau's County Business Patterns (CBP) dataset, multiplied by Census developed labor productivity rates by industry class at the state level.

### ***Fishery Flows***

The CFS omits fishery shipments that move from vessels at the dock/port to the first point of processing or distribution centers. Establishments involved in this data gap are within the NAICS category 114 (fishing, hunting and trapping). Industries in this NAICS sector harvest fish and other wild animals from their natural habitats and are dependent upon a continued supply of the natural resource. Based on statistics published in the *Fisheries of the United States 2008*<sup>12</sup>, an annual report prepared by the National Marine Fisheries Service (NMFS) of the National

---

<sup>11</sup> <http://www.epa.gov/osw/consERVE/rrr/imr/cdm/pubs/cd-meas.pdf>.

<sup>12</sup> Information obtained from the *Fisheries of the United States 2008* report, published by National Marine fisheries Service, Office of Science and Technology in July 2009, was used to supplement its 2007 report under this analysis. Although 2007 statistics are available in the *Fisheries of the United States 2007*, many are in preliminary forms. The 2008 report provides more updated information on statistics for 2007.

Oceanic and Atmospheric Administration (NOAA), commercial landings by U.S. fishermen at ports in the 50 states were totaled at approximately 4.7 million tons and valued at over \$4 billion in 2007. In addition, catches of Alaska Pollock, Pacific whiting, and other Pacific ground fish that are processed at-sea aboard U.S. vessels in the northeastern Pacific (off Washington, Oregon, and Alaska) are credited as landing to the state nearest to the area of capture. According to NMFS, these at-sea processed fishery products accounted for a total about 1.4 million tons and valued approximately \$19 million in 2007. It is assumed that this freight activity is mostly local, and that all shipments involve intra-regional FAF<sup>3</sup> truck-only movements.<sup>13</sup>

### ***Retail Industry Flows***

The 2007 CFS also does not cover shipping activities originating from the vast majority of the nation's retail stores. It is estimated that 378.6 million tons of freight were shipped by the U.S. retail industry in 2007, valued at \$624 billion. Based on the U.S. Bureau of Economic Analysis's National Input-Output Make and Use Tables, the retail industry generates commodity flows in most of the FAF<sup>3</sup> commodity classes.

Although most of the shipments from retail stores are within the same county, there is a possibility that retailers may transport large items purchased by customers from their warehouses, which may be located in other counties. At the county level this would be an issue, but is less likely to be of concern when aggregating O-D flows from counties up to FAF<sup>3</sup> regional totals. An issue with retail industry flows is whether some of these shipments are originated from retailer-owned warehouses that serve retail stores not covered by the CFS. In this case some inter-regional flows might be missing from FAF<sup>3</sup> totals. These volumes are believed to be quite small in percentage terms.

### ***Service Industry Flows***

This sector covers a wide range of services, including finance and insurance, real estate, rental and leasing, professional, scientific and technical services, administrative support, waste management and remediation services, education services, and health care and social assistance. These industries are typically involved in providing services to the general public, local business establishments, and branches of government, and in toto originate freight shipments in a large number of FAF<sup>3</sup> commodity classes. Also not covered by the 2007 CFS are the mail shipments by these service industries. The sector as a whole is estimated to have generated 378.6 million tons of commodity freight in 2007, worth just under an estimated \$504.7 billion. To this is added some 11.4 million tons of mail, valued at \$525.6 billion.

---

<sup>13</sup> Based on NMFS published statistics, total imported edible and non-edible fishery products were over 2.4 million tons and worth about \$28.8 billion in 2007. Because imports are categorized as a separate out-of-scope area of the CFS (see Section 3.3.2 in this report), to avoid double counting, imported fishery is not included under this fishery shipment data gap study.

The availability of county level sales data varies by type of service offered. For example, the county level sales data for educational services are released for only 10 states. For real estate and food services, the sales data at the county level are available for 20 states. A first step was therefore to fill in this data gap for those service industries, then sum the sales of individual types of services to obtain an overall sales statistic for each county. Shipment volumes between counties were then estimated as follows (MacroSys, 2010):

- For non-mail shipments, the county level demand for service sector products (i.e. the market potentials for these destination counties) was determined by two factors: (i) the amount of a commodity used by industries according to the Use table in the U.S. I-O model and (ii) industrial employment at counties. Next, a spatial interaction (“gravity”) model was used to distribute flows from each freight generating county to surrounding counties within our across FAF<sup>3</sup> regional boundaries.
- For mail shipments, total employment in services at the county level served as a surrogate for market potentials. Since mail is known to be shipped over long as well as short distances across the county, and lacking any empirical data on this distribution, no distance decay effect was applied to this sharing process in FAF<sup>3</sup>.

### ***Household and Business Move Flows***

It is estimated that some 254.3 million tons of freight were moved by the industrial sector, nearly all of it by truck. The value of the goods moved is estimated at just \$30.9 billion. Several sources of data on the volumes of U.S. household and business moves were examined, including the U.S. Census Bureau’s Annual Services Survey and related studies conducted by the American Trucking Association and the American Moving and Storage Association.

All of these shipments are assumed to be truck moves in FAF<sup>3</sup>. These truck shipments were allocated to counties on the basis of CBP-reported sector employment totals. The shipments are then allocated spatially between county O-D pairs based on IRS reported county level in-migration and out-migration totals. (In the absence of available data on trip length distributions, a distance decay effect was not used in this allocation process).

### ***Logging Flows***

Some 372.3 million tons of logs, totaling almost \$9.5 billion by value, are estimated to have been transported in the U.S. as a whole in 2007, of which the vast majority are transported by truck from domestic forests to nearby sawmills and other local sites. County level logging products were estimated by multiplying the year 2007 employment in logging industries, by an average tons per employee multiplier. To allow for logging products being transported across FAF<sup>3</sup> regional boundaries, these products were assigned to counties located within a 75 mile radius of the producing county, based on the employment in wood product industries within each county, and upon data collected on the average haul to market distance of logging products (e.g. sawlogs, peeler logs, OSB, pulpwood and rustic fencing).



### ***Municipal Solid Waste Flows***

Municipal solid waste (MSW) is not covered in the CFS, and also does not have a specific code in NAICS. The main data sources used for estimating 2007 MSW shipments came from information compiled by Franklin Associates<sup>14</sup> in collaboration with the U.S. EPA,<sup>15</sup> supplemented by information in the *BioCycle* journal<sup>16</sup>. Additional, mode specific data was also obtained from the U.S Army Corps of Engineers Waterborne Commerce statistics, and from the Surface Transportation Board's Railcar Waybills sample. As defined by the U.S. EPA, MSW includes the following 'Subtitle D wastes':

- Containers and packaging, such as soft drink bottles and cardboard boxes,
- Durable goods, such as furniture and appliances,
- Nondurable goods, such as newspapers, trash bags, and clothing, and
- Other wastes, such as food scraps and yard trimmings.

It is estimated that 413 million tons of MSW, as defined above, were transported within the U.S. in calendar year 2007. All of this MSW is collected at the source and transported to one of four types of processing facility: local landfills, local incineration facilities, local material recovery facilities, and waste transfer stations where garbage trucks unload MSW for accumulation and transfer to larger transport vehicles (truck, rail, or barge), for more economical long-distance hauling to a final disposal site (Curlee, 2009).

Data on the flows between states was based on work done by McCarthy (2007) for the Congressional Research Service. Combining this work with data from other sources, it is estimated that more than 42% of total state-to-state transfers (i.e. state exports) come from three states—New York, New Jersey, and Illinois, while several other states export more than 10% of the U.S. total across state lines. The District of Columbia exports all of its total MSW generation, while New Jersey exports over 45%, New York exports over 33%, and Maryland over 29%. Additional states that export more than 10% of their MSW include Connecticut, Illinois, Kansas, Massachusetts, Missouri, North Carolina, Vermont, Washington, and West Virginia. More than 46% of all these state exports go to three states—Pennsylvania, Virginia, and Michigan. Only five additional states account for more than 4% of the national total shipments of inter-state MSW—Georgia, Illinois, Indiana, New Jersey, Ohio, and Oregon. Based on ORNL discussions with local officials for the previous, FAF<sup>2</sup> effort, it appears that the large majority of shipments to adjoining states are essentially local shipments. For example, the city of Memphis ships MSW to Mississippi. Chicago ships tons to Indiana. The District of Columbia ships to Virginia. Also, small to medium sized towns near a state line may ship to an adjoining county across the state line. While these are truck movements, some longer distance shipments are by rail or (much less so) by inland waterway (i.e. by barge). It is estimated that just under 40% of inter-state

---

<sup>14</sup> <http://www.fal.com/solid-waste-management.html>

<sup>15</sup> <http://www.epa.gov/epawaste/nonhaz/municipal/msw99.htm>

<sup>16</sup> <http://www.jgpress.com/biocyte.htm>

shipments of MSW are by rail (mostly) or barge. This represents less than 4% of all MSW shipments.

The FAF<sup>3</sup> MSW estimates also include significant tonnages moving from Maine to New Brunswick, Canada, from Ontario, Canada to Michigan, and a from Ontario to New York state (Curlee, 2009). Allocation of (truck-only) MSW between FAF<sup>3</sup> regions below the state level then used county populations to distribute inter-state flows, with subsequent re-aggregation from counties to FAF<sup>3</sup> regions. County-to-county O-D flows were estimated using a spatial interaction model, using an average O-D distance of just under 32 miles, derived from the MSW literature. These inter-county flows were then aggregated to their FAF<sup>3</sup> region-to-region totals.

### ***Crude Petroleum***

It is estimated that the US transported some 744.4 million tons of crude petroleum (crude oil) in 2007, using a variety of modes. This crude was valued at some \$336.4 trillion dollars. These crude oil shipments begin either at domestic oil fields, or from large marine terminals that act as the first domestic storage and transfer point for foreign oil imports. The crude is delivered either to refineries or to long-term storage facilities such as the Strategic Petroleum Reserve.. A great deal of this transport is accomplished by pipeline, and by marine vessels (inland barge and oceangoing tanker), with significant tonnages also moved by rail tanker car and locally by tank truck.

National level crude oil shipment information by transportation mode is based on *Shifts in Petroleum Transportation* published annually by the Association of Oil Pipelines. This report's modal information is in turn based on several other data sources, including:

- Oil Pipelines: Annual Report of oil pipeline companies provided to the Federal Energy Regulatory Commission (FERC Form 6);
- Water Carriers: Waterborne Commerce of the United States, U.S. Army Corps of Engineers, (Part 5, Table 2-2);
- Motor Carriers: Petroleum Tank Truck Carriers Annual Report, American Trucking Association, Inc. and Petroleum Supply Annual, Energy Information Administration (EIA) (Volume 1, Table 46); and
- Railroads: Carload Waybill Statistics, Report TD-1, USDOT, Federal Railroad Administration, and Freight Commodity Statistics, Association of American Railroads (Table A3).

O-D flows of crude petroleum were derived using US DOE/EIA supplied data at various levels of geographic detail, ranging from five broad multi-state PADDs (Petroleum Administration for

Defense Districts)<sup>17</sup> and individual States, to specific refinery locations. This includes data from EIA's Petroleum Supply Annual (EIA, 2010) on:

- Production of Crude oil by PAD District and State,
- Refinery Input of Crude Oil by Refining Districts, and
- Refinery Receipts of Crude Oil by Method of Transportation, by PADD.

Spatial interaction (e.g. “gravity”) models were then used to disaggregate flows down to a State-to-State and FAF region-to-FAF region level. First, U.S. Census' County Business Pattern data for 2007 was used to share total crude production by state down to the county level. This allocation was based on a county's reported total annual payroll for industries classified under NAICS code 211111 – ‘Crude Petroleum and Natural Gas Extraction’.<sup>18</sup> These county activity totals were then aggregated to their respective FAF<sup>3</sup> regions. This resulted in 80 different petroleum sourcing regions, serving 50 petroleum refining FAF<sup>3</sup> regions. O-to-D allocations between these pairs of regions were then estimated using a distance-decay based spatial interaction model, applied at this broader regional level of resolution.

### *Natural Gas Products*

Delivering natural gas (principally methane, but also smaller volumes of ethane, propane, butane and pentane) is an enormous enterprise. This gas is transported to consumers through more than 300,000 miles of transmission pipelines with the help of vast storage reservoirs and thousands of compressors. This gas is sold to marketers, large commercial and industrial consumers, and distribution companies for delivery to consumers over a network of more than 1.1 million miles of local distribution pipelines.

National Natural Gas flow totals, and O-D region-to-region flows were derived from the EIAs' Natural Gas Annual (EIA, 2010)<sup>19</sup>, making use of data at various levels of geographic detail, including:

- Gross Withdrawals and Marketed Production of Natural Gas by State and the Gulf of Mexico,
- Offshore Gross Withdrawals of Natural Gas by State and the Gulf of Mexico,
- Summary of U.S. Natural Gas Imports By Point of Entry, and
- Summary of U.S. Natural Gas Exports By Point of Exit, Natural Gas Annual.

Spatial interaction models were then used, where necessary, to disaggregate flows down to a

---

<sup>17</sup> The New England, Midwest, East Coast, Gulf Coast, and West Coast PADDs. For specific state allocations to APDDs see: [http://www.eia.gov/glossary/index.cfm?id=P#PADD\\_def](http://www.eia.gov/glossary/index.cfm?id=P#PADD_def)

<sup>18</sup> The data is obtained by county level from the County Business Pattern at the U.S. Census Bureau - <http://www.census.gov/econ/cbp/intro.htm>.

<sup>19</sup> See [http://tonto.eia.doe.gov/dnav/ng/ng\\_pub\\_publist.asp](http://tonto.eia.doe.gov/dnav/ng/ng_pub_publist.asp)

State-to-State and a FAF region-to-FAF region level.

### 3.3.2 Import and Export Flows

Imported as well as exported freight flows in FAF<sup>3</sup> are constructed from a variety of data sources, each of which must have its flows converted from agency specific commodity codes to FAF<sup>3</sup>'s 2-digit SCTG codes, as well as have its flows either spatially aggregated or disaggregated to match FAF<sup>3</sup> analysis zones. Figure 3.4 provides a top-down view of this process.<sup>20</sup> The following sections describe each source data-specific procedure in more detail.

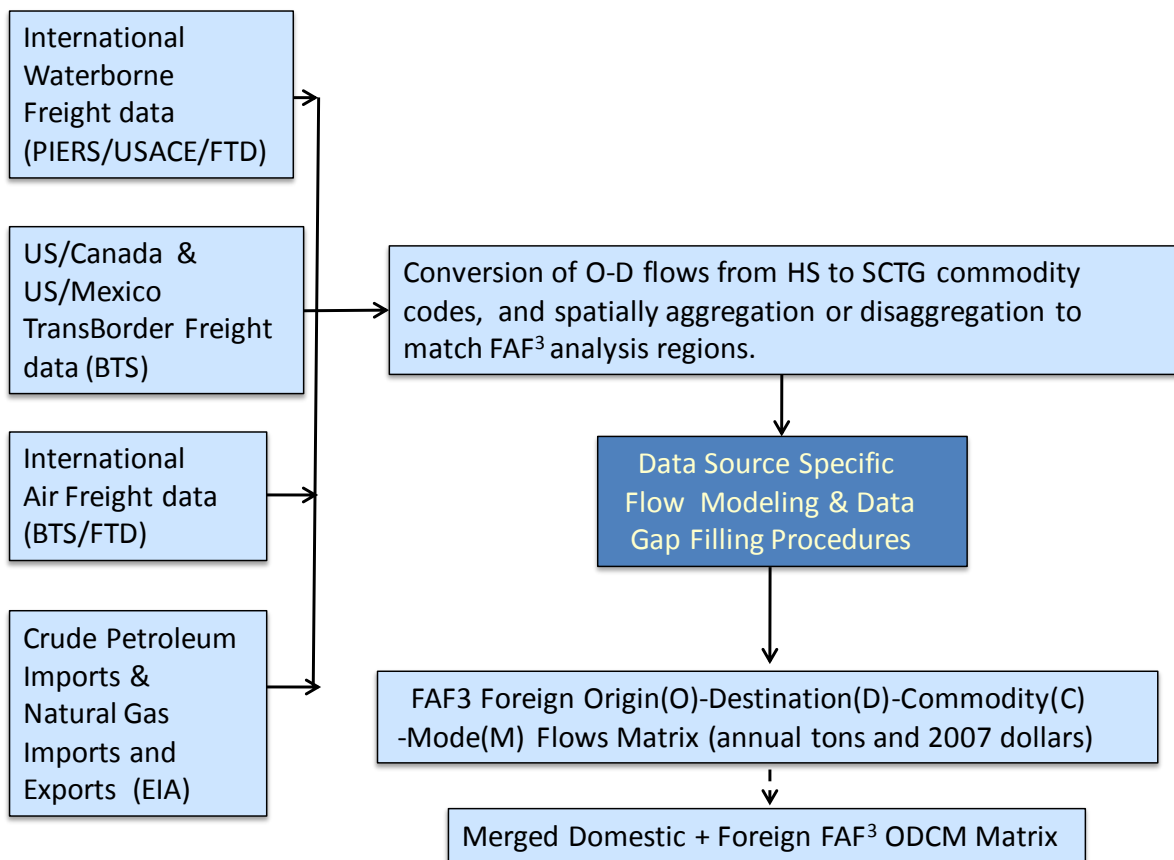

**Figure 3.4 FAF<sup>3</sup> International (Import/Export) Data Modeling**

*Waterborne Imports and Exports* are derived in FAF<sup>3</sup> using four different data sets, each of which provides a different look at the nation's international freight movements by ocean vessels:

<sup>20</sup> Although the 2007 CFS does also collect data on export shipments by US establishments, both coverage and statistical accuracy is limited by sample size issues and this data was not used as a source for FAF<sup>3</sup> export flow estimates.

- The U.S. Army Corps of Engineers International Waterborne Commerce Database<sup>21</sup>
- The U.S. Census Bureau's Foreign Trade Database<sup>22</sup>
- A FAF<sup>3</sup>-specific extraction of data from the PIERS Import/Export Database<sup>23</sup>
- Imported & Exported Petroleum & Natural Gas data from the U.S. Department of Energy's Energy Information Agency (EIA)

The availability of these last two data sources represents a significant enhancement in FAF<sup>3</sup>, and especially the PIERS dataset, which provided estimates of the internal to the U.S. distribution of imported and exported goods. In 2002, the distribution of domestic CFS shipments was used to impute domestic trip ends and modes used in FAF<sup>2</sup> for every commodity that passed through a seaport. In 2007, information from PIERS was used to impute many of these domestic trip ends, with 2007 CFS data being used to impute the modes used between U.S. seaports and their internal U.S. destinations or origins.

***International Air Freight Flows:*** Data published by the U.S. DOT's Office of Airline Information (OAI), Bureau of Transportation Statistics provided the FAF<sup>3</sup> estimates of total tons shipped annually between originating airports (where the cargo is first loaded onto an aircraft) and destination airports (where the cargo is unloaded for final land-based delivery, usually by truck).<sup>24</sup> This data is combined with data collected by U.S. Customs on the commodity class and value of international air shipments, as reported by the Foreign Trade Division (FTD) of the U.S. Department of Commerce's Bureau of the Census.<sup>25</sup> This FTD dataset includes information on the value,<sup>26</sup> quantity, method of transportation, and shipping weights for 9,000 export commodities, 17,000 imported commodities, 240 trading partners, and 45 U.S. Customs Districts.

The OAI and FTD data are combined into a single FAF<sup>3</sup> air freight dataset by reconciling differences in the level of spatial and commodity detail to match those required by the FAF. First each airport was assigned to its U.S. county, and each county to both its appropriate U.S. Customs District and FAF<sup>3</sup> region, using geographic coordinates data files available from OAI and the Census Bureau. Commodities are reported in the FTD dataset using the 10-digit Harmonized Tariff Schedule (HS Schedule B for exports). This data is aggregated and translated to FAF<sup>3</sup>'s 43 2-digit SCTG commodity classes using a crosswalk specifically developed for the purpose. Where differences exist between the OAI and FTD flow totals, the OAI database was taken to be definitive for total tons shipped, and the FTD database was used to control the

---

<sup>21</sup> <http://www.iwr.usace.army.mil/ndc/data/dataimex.htm>

<sup>22</sup> <http://www.census.gov/foreign-trade/reference/products/index.html>

<sup>23</sup> Special tabulations prepared for the FAF<sup>3</sup> project by PIERS staff. ( <http://www.piers.com/> )

<sup>24</sup> T-100 (foreign) market data. [http://www.bts.gov/publications/freight\\_transportation/](http://www.bts.gov/publications/freight_transportation/)

<sup>25</sup> <http://www.census.gov/foreign-trade/reference/products/index.html>

<sup>26</sup> Export values are reported free-alongside-ship (F.A.S.) Import values are reported as customs-insurance-freight (C.I.F) values.

allocation of freight shipments to commodity classes, and to assign value-to-weight ratios to these flows.

***U.S.-Canada and U.S.-Mexico Transborder Freight Flows:*** Truck and rail freight movements between the United States and its NAFTA neighbors Canada and Mexico are derived in FAF<sup>3</sup> from the Bureau of Transportation Statistics (BTS) Transborder Freight Database, itself constructed from data collected at border crossings by the U.S. Customs Service. After converting the Harmonized Tariff Schedule (HS) commodity classes in this dataset to FAF<sup>3</sup> SCTG classes, County Business Patterns are used to allocate flows reported at the State level to their most likely FAF<sup>3</sup> regions within the United States.

***Imports and Exports of Natural Gas and Imports of Crude Petroleum:*** Liquefied Natural Gas (LNG) is imported or exported to/from the U.S. by large tanker ships. The US Department of Energy's Energy Information Administration (EIA) reports annual LNG imports/exports in millions of cubic feet by U.S. seaport of entry/exit. The EIA also reports the annual trade in pipeline supplied natural gas (NG) between the U.S. and Canada and the U.S. and Mexico, also in millions of cubic feet. Reporting here is both by State and by specific U.S. seaport of entry/exit, requiring assignment of flows to seaport-inclusive FAF<sup>3</sup> regions.<sup>27</sup>

EIA databases were also used to estimate crude petroleum imports in FAF<sup>3</sup>, taking advantage of the fact that crude petroleum imports are reported to the EIA monthly at the company, U.S. seaport of entry/exit, and foreign country level<sup>28</sup>, allowing the complete movement of imported crude oil from the foreign country (source of commodity), passing through the port (domestic origin), to the refinery (domestic destination) to be estimated. The allocation of these flows to specific modes of transportation was then based on EIA data on crude oil refinery receipts, broken down by mode of transportation (ship, pipeline, rail, barge, truck), and further broken down by domestic versus foreign sources of production.<sup>29</sup>

## References

Curlee, T. R. (2009) The Municipal Solid Waste (MSW) Management Supply Chain: FAF<sup>3</sup> Out-of-Scope Commodity Flows. Oak Ridge National Laboratory. January, 2009 (Draft).

DOT/DOC (2006) Standard Classification of Transported Goods (SCTG). SCTG Commodity Codes. U.S, Department of Transportation/U.S. department of Commerce. 2007 Commodity Flow Survey. CFS-1200 (10-24-2006). Washington, D.C.

---

<sup>27</sup> Both the EIA's LNG and NG data sources for US Imports/exports can be found at:

[http://tonto.eia.doe.gov/oil\\_gas/natural\\_gas/info\\_glance/natural\\_gas.html](http://tonto.eia.doe.gov/oil_gas/natural_gas/info_glance/natural_gas.html)

<sup>28</sup> [http://www.eia.doe.gov/oil\\_gas/petroleum/data\\_publications/company\\_level\\_imports/cli.html](http://www.eia.doe.gov/oil_gas/petroleum/data_publications/company_level_imports/cli.html)

<sup>29</sup> [http://www.eia.doe.gov/oil\\_gas/petroleum/data\\_publications/refinery\\_capacity\\_data/refcapacity.html](http://www.eia.doe.gov/oil_gas/petroleum/data_publications/refinery_capacity_data/refcapacity.html)



EIA (2010) Natural Gas Annual 2008. Office of Oil and Gas, Energy Information Administration, U.S. Department of Energy Washington, D.C.

MacroSys (2010) Outline of Methodologies for Estimating Freight Flows of Four Out-of-Scope Industries and International Air Cargo. Report submitted to Oak Ridge National Laboratory, April, 2010.

McCarthy, J. E. (2007) Interstate Shipments of Municipal Solid Waste: 2007 Update. Congressional Research Service, Order Code RL-34043, Washington, D.C.

TRB (2006) Commodity Flow Survey Conference. *Transportation Research Circular E-2088*: 29-46. January 2006.

## Appendix A: Differences in the FAF<sup>3</sup> and FAF<sup>2</sup> Freight Flow Matrices

*The FAF<sup>3</sup> Analysis Zones* are different from the FAF<sup>2</sup> zones. Since the FAF freight flow matrix is developed around the data supplied by the U.S. Commodity Flow Surveys (CFS) the geography has changed with CFS geography. In 2007 the use of more CFS analysis zones (made possible by the much larger size of the CFS sample) allows the FAF to adopt these CFS zones while maintaining its focus on U.S. coastal analysis zones that both receive and pass on most U.S. imports and exports. This compatibility with the CFS geography should make future development of FAF flow estimates not only less time consuming but also prone to one fewer sources of possible estimation bias.

*The FAF<sup>3</sup> Mode Classes* have also changed since 2002. Table A1 below shows the differences. Note that, due to the redefinition and changed reporting of intermodal/multimodal categories between the 2002 and 2007 CFS on which the FAF is based, there is no direct equivalence in the modal classes implied between these two sets of definitions,. Differences in the way the 2007 versus the 2002 CFS assigned water-only versus water-inclusive intermodal shipments (typically, truck-water combinations) also means that direct comparisons of water only traffic volumes and modal shares is problematic.

**Table A1. Modal Class Changes 2002 – 2007**

FAF2 Modes (2002)	FAF3 Modes (2007)
Truck	Truck
Rail	Rail
Water	Water
Air, air and truck	Air, air and truck
Truck and rail	Multiple modes and Mail
Other intermodal <sup>1</sup>	Pipeline
Pipeline and Unknown	Other and Unknown

FAF<sup>2</sup> “Other intermodal” includes U.S. Postal Service and courier shipments and all intermodal combinations except air and truck.

FAF<sup>3</sup> Modal definitions are given below:

**Table A2. FAF<sup>3</sup> Modal Definitions**

Mode Identification	Mode Name	Mode Description
1	Truck	Includes private and for-hire truck. Private trucks are owned or operated by shippers, and exclude personal use vehicles hauling over-the-counter purchases from retail establishments.
2	Rail	Any common carrier or private railroad.
3	Water	Includes shallow draft, deep draft and Great Lakes shipments.
4	Air (includes truck-air)	Includes shipments typically weighing more than 100 pounds that move by air or a combination of truck and air in commercial or private aircraft. Includes air freight and air express. Shipments typically weighing 100 pounds or less are classified with <i>Multiple Modes and Mail</i>
5	Multiple Modes and Mail	Includes shipments by multiple modes and by parcel delivery services, U.S. Postal Service, or couriers. This category is not limited to containerized or trailer-on-flatcar shipments.
6	Pipeline	Includes flows from offshore wells to land, which are counted as water moves by the U.S. Army Corps of Engineers.
7	Other and Unknown	Includes flyaway aircraft, vessels, and vehicles moving under their own power from the manufacturer to a customer and not carrying any freight, unknown, and miscellaneous other modes of transport.
8	No Domestic Mode	A 'No Domestic Mode' category is used to capture petroleum imports that go directly from foreign, inbound ships to an on-shore US refinery. This is done to ensure a proper accounting when foreign and domestic flows are summed, while avoiding assigning flows to the domestic transportation network that do not use it.

FAF<sup>2</sup> modal definitions are as follows:

**1 – 4. Truck, Rail, Water and Air (including truck-air)** definitions are the same as those used in FAF<sup>3</sup>.

**5. Truck-Rail Intermodal**—Shipments that use a combination of truck and rail.

**6. Other Multiple Modes**—Includes Parcel (U.S. Postal Service or Courier), truck-water, and water-rail.

**7. Other and Unknown Modes**—Includes Pipeline and any mode not listed above.

*The FAF3 Commodity Classes*, like those in FAF<sup>2</sup>, mirror the 43, 2-digit (i.e. most aggregate) SCTG classes reported by the 2007 CFS. Differences in the composition of these classes between 2002 and 2007 are relatively minor, with two exceptions:

- Printed product flows, which were absent from the 2002 CFS and hence modeled as OOS flows in FAF<sup>2</sup> were covered in the 2007 CFS.
- A second change for FAF<sup>3</sup> was the O-D specific treatment of natural gas products, which were evaluated only at the level of national or broad regional activity totals in FAF<sup>2</sup>.

## **Appendix C**

### **Economic Impact Analysis**

**Preface for Appendix C Economic Impact Analysis:**

Alternative 1 referenced in the Economic Impact Analysis (Appendix C) is not the same as the alternatives evaluated in the EIS. The analysis in the EIS for the Proposed Project Alternative is based on 1.7 million TEUs (referred to as the Optimistic Scenario, Build option in this appendix). The document is also used for source documentation (e.g., industry standards used in the analyses within the EIS).



Economic Impacts from Port of Gulfport Container Terminal  
Renewal and Development

May 17, 2012

FINAL

**PARSONS  
BRINCKERHOFF**



Table of Contents

- 1. Introduction ..... 1
- 2. Economic Impacts from Container Terminal Construction..... 2
- 3. Economic Impacts from Increased Annual Container Activity..... 4
  - Operations Estimates - TEUs ..... 5
  - Direct In-Port and Off-Port Services Employment: In-Port Cargo Handling & Off-Port Warehousing, Distribution and Other Support Services Employment ..... 5
  - Warehousing and Distribution: Materials, Supplies and Contract Services Spending ..... 8
  - Total Impacts ..... 8
- 4. Special Economic Sector Studies ..... 12
  - Geography and Project Understanding ..... 12
  - Truck Traffic Projections ..... 13
  - Commercial Fishing and Shrimp Industries..... 14
  - Leisure and Tourism Industries ..... 15
  - Charter Boats and Fishing Industry ..... 16
  - Appendix: Selected Businesses within Study Area ..... 18

## List of Tables

Table 1 Capital Costs by Industry Category .....	3
Table 2 Total Economic Impacts from Port of Gulfport Construction .....	3
Table 3 Container Volume Forecasts, No-Build vs. Port Alternative 1 .....	5
Table 4 Direct In-Port and Off-Port Labor Requirements for Future Port Activity Generated by Project.....	6
Table 5 Direct In-Port and Off-Port Employee Compensation from Future Port Related Activity Generated by Project....	7
Table 6 Changes in Non-Wage Spending by Transportation and Warehousing Firms from Port Activity.....	8
Table 7 Total Economic Impacts from Future Port Related Activity Generated by Project.....	10

## List of Figures

Figure 1 Port of Gulfport Expansion Study Area .....	12
Figure 2 Commercial Shrimp and Fishing Employers within the Study Area.....	14
Figure 3 Leisure and Tourism Employers within the Study Area .....	16
Figure 4 Charter Boat and Fishing Employers within the Study Area.....	17

## 1. Introduction

This report assesses the future economic impacts of the Gulfport Container Terminal expansion project. It evaluates the following sets of impacts associated with Alternative 1:

- Time limited economic impacts associated with the construction of Alternative 1
- Annual impacts of Alternative 1 from increased container volume and associated container handling and related support activities, for years 2020 through 2060 in ten year increments.
- Potential benefits to regional port related industries, including direct support industries such as trucking and general purpose warehousing and distribution, as well as potential growth in industries that would find advantages from proximity to an expanded and more efficient container facility, such as export oriented manufacturing, manufacturing relying on intermediate product imports for final assembly, and big box retailers which may find supply chain advantages from port proximity

The report also includes an assessment of potential negative impacts on key regional industries, such as tourism, recreational boating, and commercial fishing. Potential for disruptions due to increased truck volumes, visual effects, or “encroachment” into the activity areas of these industries by an expanded port footprint or due to increased shipping volumes are assessed.

Estimates of construction related economic impacts are relatively straightforward, and are based on the construction costs, the phasing of construction, and state level economic models that are used to derive overall economic impacts including direct as well as indirect and induced effects. Direct effects include direct construction, while indirect impacts include, respectively, the additional rounds of economic activity triggered by construction spending, and additional rounds of consumption arising from the original direct gains in construction sector wage earnings. Impacts measured include employment, wage earnings, total public and private sector output (e.g., total payments to all industries and households in the region), addition to Gross State and Regional Product, and state and local tax revenues.

Estimates of annual impacts from increased port volume and operations are assessed for the increment of additional container throughput associated with the expansion project, compared with a No-Build port scenario. Additional container throughput (relative to the No-Build) is estimated based on Parsons Brinckerhoff’s updated market demand forecast (see ‘Gulfport Container Volume Projections”, Parsons Brinckerhoff, and January 2012).

Impacts from annual container operations include in port employment and spending, as well as major off-port support activities: truck drayage, general warehousing and distribution, and other shipping and container trade support activities such as freight forwarding. As in the case of construction impacts, economic models are applied to these direct effects to arrive at total impacts. Impacts include similar metrics as are estimated for construction, including employment, wage earnings, output, Gross State and Regional Product, and state and local tax revenues.

## 2. Economic Impacts from Container Terminal Construction

The Gulfport Expansion project will generate a significant level of short-term economic activity that would create hundreds of needed jobs in the Gulfport region. Once underway, the Project would immediately generate construction jobs that could potentially be filled by currently unemployed or underemployed construction workers, providing much needed business to local construction contractors and construction materials suppliers. The Project is expected to generate broad increases in economic activity that would create both low- and high-skilled jobs across various industries.

An input output economic model customized for the state of Mississippi has been used to estimate total economic impacts, including indirect and induced, economic impacts. This model, obtained from MIG, Inc., (IMPLAN)<sup>1</sup>, has been used to determine the employment, earnings, business output, Gross Domestic Product (GDP) and taxes created in the short-term during project construction. IMPLAN economic models were applied to the increase in construction demand to estimate three types of impacts:

- Direct impacts represent new spending, hiring, and production by civil engineering construction companies to accommodate the demand for resources in order to complete the project.
- Indirect impacts result from the increase in production of industries supplying intermediate goods and services to the civil engineering construction industry. Such firms will also experience increased demand for their products and, if necessary, will hire new workers to meet the additional demand.
- Induced impacts stem from the re-spending of wages earned by workers/households benefitting from the direct and indirect activity. In other words, if an increase in labor demand leads to earnings in a set of industries, workers in these industries will spend some proportion of their increased earnings at local retail shops, restaurants, and other places of commerce, further stimulating economic activity.

The construction cost for the Port of Gulfport Expansion is estimated to be \$949,765,000 (without contingency) in 2009 dollars. These expenditures are expected to be made over a 5 year construction period. For analysis purposes, construction costs are broken into industries as follows:

---

<sup>1</sup> IMPLAN, MIG Inc. [http://implan.com/V4/index.php?option=com\\_content&view=frontpage&Itemid=1](http://implan.com/V4/index.php?option=com_content&view=frontpage&Itemid=1)

Input-output models capture the inter-industry linkages of a regional economy and estimate economic multipliers, which quantify the effects of increases in final demand on employment, earnings, and economic output within a specified county, region, or state.

Table 1 Capital Costs by Industry Category

Budget category	Study Industry	Estimated cost (2009 \$)
Construction Costs	Transportation construction	\$897,000,000
Design and construction services	Professional Services	\$9,515,000
Construction management / construction materials testing	Professional services	\$43,250,000

Source – Mississippi State Port Authority

Since the costs are primarily civil construction, which is a highly localized activity for which contractors procure labor and most materials locally/regionally, nearly all of this spending can be assumed to occur within the regional and local economy. Thus, benefits will largely be felt regionally and locally.

Furthermore, additional employment from construction activity is likely to occur under conditions of excess capacity in the construction industry. There is presently high construction sector unemployment in the region, with the likelihood of this continuing for some time to come. Furthermore, the project is likely to be funded with a high ratio of external funds from the Federal and state governments, reducing the local fiscal impact of the project. Therefore impacts on the state and regional economy may be regarded as largely a net addition to the state and regional economy.

On a cumulative basis, the \$949.8 million (2009 \$) construction of the Port of Gulfport Expansion is likely to impact the local economy in the following ways<sup>2</sup>:

Table 2 Total Economic Impacts from Port of Gulfport Construction

	Cumulative amount (5-year total)	Average Annual Impact
Total Employment (job-years)	13,833	2,767
Total Wage Earnings (2011 \$)	\$553,229,909	\$110,645,982
Total Output (2011 \$)	\$1,676,676,089	\$335,335,218
Increase in State GDP <sup>3</sup> (2011 \$)	\$746,303,997	\$149,260,799
State and Local Taxes (2011 \$)	\$47,653,402	\$9,530,680

Source – Mississippi State Port Authority

The construction of the project is likely to sustain on average over 2,700 jobs per year over its five year construction period. This includes direct jobs related to the actual construction of the project, in

<sup>2</sup> Capital cost inputs originally reported in real 2009 dollars. Economic impacts reported in real 2011 according to IMPLAN inflationary estimates.

<sup>3</sup> State GDP reflects the total of pre tax wage and business earnings, including business profits business retained earnings, additions to inventory, dividends, and several other categories. It is conceptually similar to GDP. It can also be defined as the sum of the value of all *final* goods and services produced within the state economy, or the sum of value added. GDP increases are obtained from the value added estimate from the IMPLAN economic model.



addition to jobs created by secondary suppliers and elsewhere in the economy. It also includes the forward or induced economic impacts from additional household consumption. The annual jobs per year are averages – in fact, the project construction schedule is more likely to peak sometime midway during the five year construction period, so that more jobs will be supported in the middle years of construction, and possibly fewer during the start up and wind down of the project.

### 3. Economic Impacts from Increased Annual Container Activity

The additional container volumes and the larger port facility will generate increased demand for in-port labor, in-port purchases of materials and supplies, and economic activities directly needed off port to complete the handling of these containers. Handling is primarily warehousing and distribution, truck drayage, other container transport services, and some miscellaneous activities such as freight forwarders and ship services.

Estimates of annual impacts from increased port volume and operations are assessed for the increment of additional container throughput compared with a No-Build port scenario, which includes the capacity enhancements associated with the Restoration project. The economic impacts estimated here are incremental to No-Build employment and service requirements. The current port now handles approximately 210,000 twenty-foot-equivalent-units (TEUs) per year, but also handles substantial non-containerized cargo.

Additional container throughput (relative to the No-Build) is estimated based on Parsons Brinckerhoff's updated market demand forecast ("Gulfport Container Volume Projections", Parsons Brinckerhoff, January 2012). That report assesses the prospects for container growth through the Port of Gulfport based on factors including Panama Canal expansion, the potential for increased market share for specific trade lanes such as Latin America to the U.S. Gulf Coast, baseline U.S. and regional import demand growth trends, inland rail network improvements connecting the Gulf ports with the U.S. inland, as well as the benefits of improved Gulfport facilities. The impact of port expansion/improvements will include operational and capacity enhancements from dredging for a larger turning basin and expanding available wharf and cargo handling space. These will increase the competitiveness of the port, allowing it to attract more and larger shipping, improving prospects for additional liner rotations, ship calls, and higher market capture rate at Gulfport. The container forecasts in that report include pessimistic, baseline, high and optimistic growth scenarios.

For purposes of this analysis, only the high growth and optimistic scenarios are considered relative to the No-Build baseline scenario. Volumes were initially projected through 2040, and extrapolated to 2050 and 2060 using the compound annual growth rate between 2030 and 2040.

The pessimistic scenario was not considered, as it will generate only moderately less impact than the baseline scenario. Under the pessimistic scenario, volumes are estimated to grow to about 1.07 million TEU by 2060.

Table 3 Container Volume Forecasts, No-Build vs. Port Alternative 1

Incremental TEUs	2010	2020	2030	2040	2050	2060
<b>High-Growth Scenario</b>						
No –Build (Baseline)	217,948	287,732	411,671	563,982	769,398	1,049,631
Build	217,948	316,055	453,410	651,893	889,328	1,213,242
Incremental	-	28,323	41,739	87,911	119,930	163,611
<b>Optimistic Scenario</b>						
No –Build (Baseline)	217,948	287,732	411,671	563,982	769,398	1,049,631
Build	217,948	487,732	711,671	963,982	1,289,238	1,725,215
Incremental	-	200,000	300,000	400,000	519,840	675,584

Source – Parsons Brinckerhoff “Gulfport Container Volume Projections,” January 2012.

## Operations Estimates - TEUs

As indicated the first step of this analysis was to identify the level of port and direct port related activity expected over time. Summarizing the market estimates above, it has been assumed that the project would increase port container volumes at the facility by a range between 164,000 annual TEU and 676,000 annual TEUs relative to the No-Build baseline by 2060, depending on the market forecast scenario. The increase above and beyond a “no build” scenario (the baseline), or the “marginal” increase in TEUs is what can be considered the impact of the project. This can be seen in the “incremental” numbers in Table 3.

## Direct In-Port and Off-Port Services Employment: In-Port Cargo Handling & Off-Port Warehousing, Distribution and Other Support Services Employment

Additional container volumes generate employment in four ways: 1) direct on-port container handling activity; 2) off-port warehousing, distribution and truck drayage of containers; 3) other off port services such as freight forwarders and ship services; and 4) other container transport associated with rail shipments. Based on a range of previous studies and information, a full time equivalent (FTE) per 1,000 TEUs figure could be estimated for the first three categories.<sup>4</sup> Other container transport is discussed later.

For a conventional terminal, it was determined that the labor needs for in-port activity (ILA stevedoring and other in-port functions) is 1.25 FTE employees per 1,000 TEUs. (Analysis of a more technically automated port indicates FTE ratios of about half of this.) The warehousing and distribution sector (including truck drayage) would require an additional 2.65 employees per 1,000 TEUs, while other off-port activities would require 0.858 employees per 1,000 TEUs. In sum, it is estimated that total employment needs for a port are 4.758 employees per 1,000 TEUs. This includes direct on-port activity,

<sup>4</sup> Sources include “The Projected Economic Impacts from Container Terminal Development at Gulfport: Update”, TranSystems, January 2011; confidential analyses by Parsons Brinckerhoff of port expansion for a container terminal in the New York region (truck drayage and warehousing and distribution component); Le-Griffin, Hahn-Le and Melissa Murphy, “Container Terminal Productivity: Experiences at the Port of Los Angeles and Long Beach, Feb. 2006, University of Southern California, Dept. of Civil Engineering; MARAD Port Economic Impact Kit.

as well as the indirect employment from warehousing and distribution and other off-port activity. Assuming no changes in technology over time, the total labor requirements are calculated below.

Table 4 Direct In-Port and Off-Port Labor Requirements for Future Port Activity Generated by Project

Labor Requirements	2020	2030	2040	2050	2060
<b>High-Growth Scenario</b>					
Labor Needs Per 1,000 TEU					
In-Port Activity	1.25	1.25	1.25	1.25	1.25
Warehousing/Distribution	2.65	2.65	2.65	2.65	2.65
Other off-port support activity	0.858	0.858	0.858	0.858	0.858
Total	4.758	4.758	4.758	4.758	4.758
Labor requirements per year (annual FTE)					
In-Port Activity	35	52	110	150	205
Warehousing/Distribution	75	111	233	318	434
Other off-port support activity	24	36	75	103	140
Total	135	199	418	571	778
<b>Optimistic Scenario</b>					
Labor Needs Per 1,000 TEU					
In-Port Activity	1.25	1.25	1.25	1.25	1.25
Warehousing/Distribution	2.65	2.65	2.65	2.65	2.65
Other off-port support activity	0.858	0.858	0.858	0.858	0.858
Total	4.758	4.758	4.758	4.758	4.758
Labor requirements per year (annual FTE)					
In-Port Activity	250	375	500	650	844
Warehousing/Distribution	530	795	1,060	1,378	1,790
Other off-port support activity	172	257	343	446	580
Total	952	1,427	1,903	2,473	3,214

Source – Parsons Brinckerhoff

To be consistent with the input-output analysis software utilized for this economy, certain characteristics of the structural economy of Mississippi were utilized.<sup>5</sup> Among these economic indicators was the total employee compensation per employee in each industry. Assuming no real wage growth over time, the following table indicates the total wage earnings, or labor income, for employees employed directly or indirectly at the facility:

<sup>5</sup> Minnesota IMPLAN Group, IMPLAN, Statewide Mississippi.

Table 5 Direct In-Port and Off-Port Employee Compensation from Future Port Related Activity Generated by Project

Employee Compensation	2020	2030	2040	2050	2060
<b>High Growth Scenario</b>					
Total compensation per employee (2011 \$)					
On-Port Activity	\$77,242	\$77,242	\$77,242	\$77,242	\$77,242
Warehousing/ Distribution	\$35,963	\$35,963	\$35,963	\$35,963	\$35,963
Off-port activity	\$38,139	\$38,139	\$38,139	\$38,139	\$38,139
Total Industry Employee Compensation per year (2011 \$)					
On-Port Activity	\$2,734,655	\$4,030,002	\$8,488,021	\$11,579,533	\$15,797,040
Warehousing/ Distribution	\$2,699,206	\$3,977,762	\$8,377,993	\$11,429,431	\$15,592,268
Off-port activity	\$926,826	\$1,365,844	\$2,876,752	\$3,924,524	\$5,353,917
Total	\$6,360,687	\$9,373,609	\$19,742,766	\$26,933,489	\$36,743,226
<b>Optimistic Scenario</b>					
Total compensation per employee (2011 \$)					
On-Port Activity	\$77,242	\$77,242	\$77,242	\$77,242	\$77,242
Warehousing/ Distribution	\$35,963	\$35,963	\$35,963	\$35,963	\$35,963
Off-port activity	\$38,139	\$38,139	\$38,139	\$38,139	\$38,139
Total Industry Employee Compensation per year (2011 \$)					
On-Port Activity	\$19,310,487	\$28,965,730	\$38,620,974	\$50,191,817	\$65,229,280
Warehousing/ Distribution	\$19,060,170	\$28,590,256	\$38,120,341	\$49,541,195	\$64,383,731
Off-port activity	\$6,544,691	\$9,817,037	\$13,089,383	\$17,010,962	\$22,107,444
Total	\$44,915,349	\$67,373,023	\$89,830,697	\$116,743,974	\$151,720,454

Source – Parsons Brinckerhoff analysis based on IMPLAN and per TEU factors in Table 4

## Warehousing and Distribution: Materials, Supplies and Contract Services Spending

Thus far, impacts have included the direct employment impacts of the port as well as the i.e., off port support service employment impacts generated from trucking drayage, warehousing and distribution and other container services off-port. These estimates are for labor only, and have not included purchases of materials, supplies, and other services by these sectors (the port, warehousing and distribution, and truck drayage firms) that would have a further impact on the economy.

Such impacts can be estimated for the combined warehousing, distribution and truck drayage firms serving the port and its additional container throughput. Traditionally, the warehousing and distribution industry (a component of the labor costs above) is likely to have expenditures well beyond the costs of labor. According to latest American Transportation Research Institute<sup>6</sup> data, the ratio of truck driver wages and benefits to other costs is 0.59. This means that other costs are about 1.7 times the truck drivers' wages and benefits. Thus, by multiplying the total warehousing and distribution industry labor income in Table 4 by approximately 1.7, the non-labor costs for the industry can be estimated.

These costs can be viewed as a change in final demand to the transportation and warehousing industry. These impacts can then be multiplied throughout the economy. The following table indicates the estimated changes to non-wage costs in the transportation and warehousing industry, which are interpreted as changes in final demand.

Table 6 Changes in Non-Wage Spending by Transportation and Warehousing Firms from Port Activity.

Non-Wage Spending Increases for Warehousing and Distribution (2011 \$)	2020	2030	2040	2050	2060
High-Growth Scenario	\$4,574,925	\$6,741,970	\$14,199,988	\$19,371,917	\$26,427,572
Optimistic scenario	\$32,305,374	\$48,458,060	\$64,610,747	\$83,968,127	\$109,124,968

Source – Parsons Brinckerhoff

### Total Impacts

Total impacts for the region were derived in three parts. The first two were described above, and reflect “first round” increases in economic activity. These include, as described above:

- direct in-port and off-port services employment and wages

<sup>6</sup> American Transportation Research Institute, Analysis of the Operational Costs of Trucking: June 2011 Update.

- non wage spending for materials, supplies and services for transportation, warehousing and distribution

To complete the analysis of full regional economic impacts, Input Out based multipliers were applied. These provide estimates of the indirect and induced effects (i.e., the multiplier effects) of the additional payments to labor (Table 5), and for materials, supplies and services (Table 6). Specifically, these are calculated utilizing economic multipliers provided by IMPLAN. These indirect and induced, or multiplier effects, are combined in Table 7 with the direct impacts to arrive at the total changes in regional employment, wage earnings, output, value added, and state and local taxes. These indirect and induced effects are explained below:

- Induced effects from wage earnings arise as the additional employee compensation for in-port workers, and workers in warehousing and distribution, would cycle throughout the economy as the earnings are spent at various retail and other businesses in many sectors throughout the economy (food, shelter, clothing, services, etc.). Thus, the changes to employee compensation (the totals from Table 5) were applied to the economy to identify the total induced impacts in terms of employment, wage earnings, output, Gross State Product (i.e., value added) and state and local taxes.
- Indirect effects resulting from changes in final demand (i.e., increased to the warehousing and distribution industry (shown in Table 6 above) were also applied to the economy. These changes to final demand had multiplying effects, as the warehousing and distribution industry requires secondary goods and services from other industries, and its employees spend their incomes in the economy. These impacts were also added to the total.

Table 7 presents total impacts on the regional and state economy generated from the project from 2030 to 2060. Impacts include total employment, wage earnings, output, value added, and state and local tax impacts. Tax impacts represent all state and local taxes combined.

Table 7 Total Economic Impacts from Future Port Related Activity Generated by Project

Economic Impacts per year	2020	2030	2040	2050	2060
<b>High-Growth Scenario</b>					
<b>Employment (job-years)</b>					
Direct (including warehousing, distribution and trucking)	135	199	418	571	778
Indirect	55	82	172	235	320
Induced	62	91	191	261	355
Total	252	371	781	1,066	1,454
<b>Wage Earnings (2011 \$)</b>					
Direct (including warehousing, distribution and trucking)	\$6,360,687	\$9,373,609	\$19,742,766	\$26,933,489	\$36,743,226
Indirect	\$2,525,932	\$3,722,412	\$7,840,173	\$10,695,726	\$14,591,331
Induced	\$2,013,066	\$2,966,613	\$6,248,302	\$8,524,062	\$11,628,703
Total	\$10,899,685	\$16,062,634	\$33,831,241	\$46,153,277	\$62,963,260
<b>Total Output (2011 \$)</b>					
Direct (including warehousing, distribution and trucking)	\$25,308,406	\$37,296,457	\$78,554,082	\$107,165,100	\$146,196,858
Indirect	\$5,971,497	\$8,800,069	\$18,534,771	\$25,285,519	\$34,495,029
Induced	\$6,240,716	\$9,196,810	\$19,370,392	\$26,425,487	\$36,050,199
Total	\$37,520,619	\$55,293,336	\$116,459,245	\$158,876,106	\$216,742,086
<b>Total Value Added (Gross State Product) (2011 \$)</b>					
Direct (including warehousing, distribution and trucking)	\$6,360,687	\$9,373,609	\$19,742,766	\$26,933,489	\$36,743,226
Indirect	\$3,157,891	\$4,653,717	\$9,801,692	\$13,371,672	\$18,241,912
Induced	\$3,708,108	\$5,464,561	\$11,509,500	\$15,701,496	\$21,420,308
Total	\$13,226,686	\$19,491,887	\$41,053,958	\$56,006,657	\$76,405,446
<b>Total State and Local Taxes (2011 \$)</b>					
	\$554,138	\$816,623	\$1,179,976	\$2,346,426	\$3,201,045
<b>Optimistic Growth Scenario</b>					
<b>Total Employment (job-years)</b>					



Economic Impacts per year	2020	2030	2040	2050	2060
Direct (including warehousing, distribution and trucking)	952	1,427	1,903	2,473	3,214
Indirect	391	587	782	1,016	1,321
Induced	435	652	869	1,129	1,468
Total	1,777	2,666	3,554	4,619	6,003
<b>Total Wage Earnings (2011 \$)</b>					
Direct (including warehousing, distribution and trucking)	\$44,915,349	\$67,373,023	\$89,830,697	\$116,743,974	\$151,720,454
Indirect	\$17,836,615	\$26,754,922	\$35,673,229	\$46,360,929	\$60,250,653
Induced	\$14,215,065	\$21,322,594	\$28,430,125	\$36,947,792	\$48,017,343
Total	\$76,967,029	\$115,450,539	\$153,934,051	\$200,052,695	\$259,988,450
<b>Total Output (2011 \$)</b>					
Direct (including warehousing, distribution and trucking)	\$178,712,749	\$268,069,123	\$357,425,497	\$464,510,176	\$603,677,368
Indirect	\$42,167,129	\$63,250,691	\$84,334,258	\$109,600,803	\$142,437,180
Induced	\$44,068,192	\$66,102,276	\$88,136,372	\$114,542,032	\$148,858,800
Total	\$264,948,070	\$397,422,090	\$529,896,127	\$688,653,011	\$894,973,348
<b>Total Value Added (Gross State Product) (2011 \$)</b>					
Direct (including warehousing, distribution and trucking)	\$44,915,349	\$67,373,023	\$89,830,697	\$116,743,974	\$151,720,454
Indirect	\$22,299,128	\$33,448,691	\$44,598,254	\$57,959,893	\$75,324,665
Induced	\$26,184,438	\$39,276,651	\$52,368,871	\$68,058,586	\$88,448,923
Total	\$93,398,915	\$140,098,365	\$186,797,822	\$242,762,453	\$315,494,042
<b>Total State and Local Taxes (2011 \$)</b>					
	\$3,912,995	\$5,869,492	\$7,825,989	\$10,170,658	\$13,217,780

Source – Parsons Brinckerhoff

## 4. Special Economic Sector Studies

PB has conducted special studies to examine the possibility of negative economic impacts resulting from Port expansion on key economic sectors and activities in the Gulfport area. Effects may result from increased truck traffic on local roads due to increased container volumes, encumbrance on waterfront property, or other aesthetic or environmental effects on the local area.

This section examines three industries with exceptional importance to the Gulfport region to which Port expansion may generate negative economic impacts: commercial shrimp and fishing, tourism (including leisure, hospitality and gaming), and charter boating and fishing. The following sections describe the proposed project and its potential effects on these sectors.

### Geography and Project Understanding

The Study Area for the Port of Gulfport expansion encompasses a majority of Mississippi's 26 miles of mainland coast along the Gulf of Mexico, which is home to the vast majority of the State's commercial and recreational boating and fishing activity. The area also serves as one of the region's major tourist destinations. The Port itself is centrally located on Mississippi's Gulf Coast, just south of the junction between US-49 and US-90, as seen in Figure 1, below.

Figure 1 Port of Gulfport Expansion Study Area



Source – ATKINS

For the purpose of this study there are two central factors to consider when evaluating potential impacts of the Port expansion project: those occurring offshore, mainly the renovation of the Port itself;

and those occurring onshore, mainly the effect of Port expansion on surface transportation infrastructure leading to the Port.

### Port Improvements

Much of the physical Port expansion is occurring on offshore infrastructure by extending facilities further south into the Gulf. The Port of Gulfport has been operational since 1902, and since then has been a highly visible presence on the Gulf coast, both from downtown Gulfport and along the miles of open waterfront to its east and west. As such, residents and visitors are accustomed to the aesthetics of an operational port. The expansion will not significantly alter the aesthetic appearance and therefore is not expected to deter business or other commercial or recreational activity from that perspective. Moreover, because the Port's physical footprint along the shoreline will not change, it will not have the effect of "pushing out" any waterfront businesses in the immediate vicinity.

### Surface Improvements

Due to the limited change in the Port's footprint from the expansion project, it is likely that if the project were to generate any negative impacts on surrounding industries it would come from ancillary activity related to increased demand on infrastructure such as surface roadways and interstates, in particular critical routes US-90 (east-west along Harrison County coast), US-49 (running north from the Port), and I-10 (running east-west approximately 4.5 miles north of the port with access to New Orleans to the west and Mobile to the east). These routes are doubly important due to their proximity to the region's retail, commercial and industrial corridors. While not a part of the actual Port expansion project, there are several other independent projects planned in the area are expected to alleviate concerns.

The most significant surface infrastructure project is the future I-310 Connector proposed by Mississippi Department of Transportation. The proposed roadway is a limited-access highway that will connect I-10 to 30<sup>th</sup> Avenue in downtown Gulfport with direct access to the Port facilities. I-310 will divert all north- and southbound truck freight traffic off of US-49, leaving that thoroughfare open to regular non-port traffic. Current plans call for the potential addition of an elevated connection between I-310 and the West Pier at Gulfport, further reducing conflict with surface traffic by eliminating the at-grade intersection with US-90. These steps will remove the majority of port traffic that currently uses US-90 and US-49. Current estimates suggest I-310 may draw as much as one-third of the current daily traffic on US-49 south of I-10.

Similar improvements will be made to the rail line connecting the Port to freight rail infrastructure.

In general, the alleviation of truck traffic along US-49 will mean easier access for tourist and residential traffic to the large commercial developments along the corridor.

## Truck Traffic Projections

In 2010 the Mississippi State Port Authority (MSPA) located at the Port of Gulfport handled 208,000 TEUs of containerized cargo. While down from a peak of 230,000 TEUs in 2005, volume has increased steadily in the years following Hurricane Katrina. Currently 95 percent of container freight exits the port by truck via I-49 North, or approximately 197,600 TEUs in 2010.

Under the optimistic growth scenario presented in the Gulfport Container Volume Projections, container volumes could grow to nearly 500,000 TEUs in 2020 and 700,000 TEUs in 2030. However, under the current Port expansion plan and associated surface transportation improvements, the percentage of cargo leaving the port by truck will decline from 95 to 50 percent, equating to 250,000 TEUs in 2020 and 350,000 TEUs in 2030; the remaining 50 percent will leave by rail. It is anticipated that nearly all truck cargo traffic leaving the port will utilize the new I-310 connector, bypassing I-49 completely.

The optimistic growth scenario represents an effective “worst case scenario” for truck traffic in the Gulfport area; with less optimistic growth, truck volumes will be lower. Overall, despite growth in trucking volume, increased dependence on other modes of transport and a dedicated highway route further away from the Gulfport central business district should generate a mostly positive impact on local businesses in terms of truck traffic.

The following sections will examine potential industry-specific conflicts generated by Port expansion.

### Commercial Fishing and Shrimp Industries

The Gulfport-Biloxi Metropolitan Statistical Area (MSA) is home to several dozen commercial fisheries and distributors and hundreds of professional shrimp and fisherman operating out of Mississippi Sound. Employment in the commercial shrimp and fishing industries was 8,500 statewide in 2010; more specific data is not currently available, though it is reasonable to assume the vast majority of that employment is located along the Gulf coast and, consequently, within the Study Area. The majority of these companies are small, independent operations.

Figure 2 Commercial Shrimp and Fishing Employers within the Study Area<sup>7</sup>

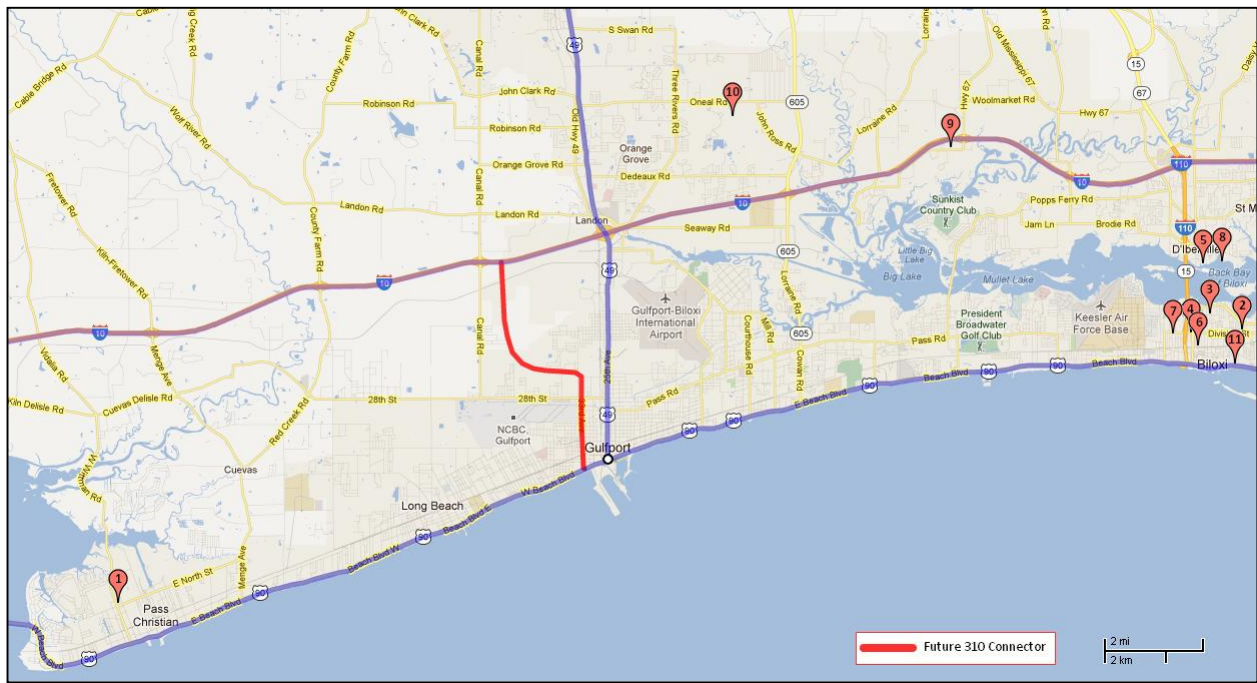

<sup>7</sup> See Appendix for list of businesses labeled in Figure 2

*Source – Google Maps, Parsons Brinckerhoff*

Figure 2 above maps eleven of the top commercial shrimp and fishing companies in the Study Area. This map is not complete, but it is representative; locations displayed above represent clusters of commercial fishing activity in the Gulfport region. The majority of commercial fishing companies operate out of the harbors along Biloxi Bay and further east (outside of the study area) in Pascagoula. Relatively few operate in the City of Gulfport or points directly west, and no reported businesses operate directly along the proposed I-310 corridor. Centering commercial operations in close proximity to safe harbors like that in Biloxi allows for efficient transfer of catch to processing. It is reasonable to expect Port expansion activity to have minimal effect on those fisheries still operating post-Katrina and Deepwater Horizon.

Projecting sector and commercial growth within the Study Area is difficult due to the unique circumstances surrounding devastation caused by Hurricane Katrina and the Deepwater Horizon oil spill, but it is unlikely that even robust growth would be prohibited by the Port expansion due to the reasons outlined above. Overall, there is much uncertainty over future business activity and investment due to the non-normal development experienced from 2005 to present. This rings even more true with marine-related industries.

### Leisure and Tourism Industries

The leisure and tourism industries along the Mississippi Gulf Coast have increased in market share in recent years. Due to the major damage done along the coast by Hurricane Katrina, much of the tourism activity now centers on golf and gaming in particular, as well as hotels and hospitality services that go along with them. This represents a significant portion of the local economy; direct tourism employment was 22,000 in Harrison County in 2009, representing nearly one-quarter of all nonfarm employment.

Alone, casinos employ 8,900 in the Gulfport-Biloxi MSA. Beau Rivage Casino employs over 4,100 making it the largest private employer in Harrison County (behind Keesler Air Force Base and the Naval Construction Battalion Center). Together, casinos represent seven of the fifteen largest employers in the County, each with over 1,000 employees as of 2009.

Figure 3 below maps the ten casinos (yellow) and eight golf courses (red) within the Study Area. Hotels (not mapped) tend to concentrate along US-90 east of the Port and along the I-40/US-49 interchange; there are approximately 60 hotels in the Study Area, with only one, the Island View Casino Resort, in direct proximity to the proposed I-310 Connector. Casino activity is concentrated in the Biloxi peninsula with some activity further west along US-90. The only casino facility within proximity of the Port is the Island View Casino Resort. Golf courses are naturally dispersed throughout the Study Area south of I-10, all far from any Port activity or associated truck traffic.

Due to the geographic distribution of these businesses relative to the Port and the fact that the vehicle traffic accessing these facilities will rely primarily on alternate routes (such as I-110), these businesses are not expected to compete significantly with increased truck traffic into and around the Port. As such, there is no clear indication that Port expansion activity would have an impact on those activities.



Figure 3 Leisure and Tourism Employers within the Study Area<sup>8</sup>

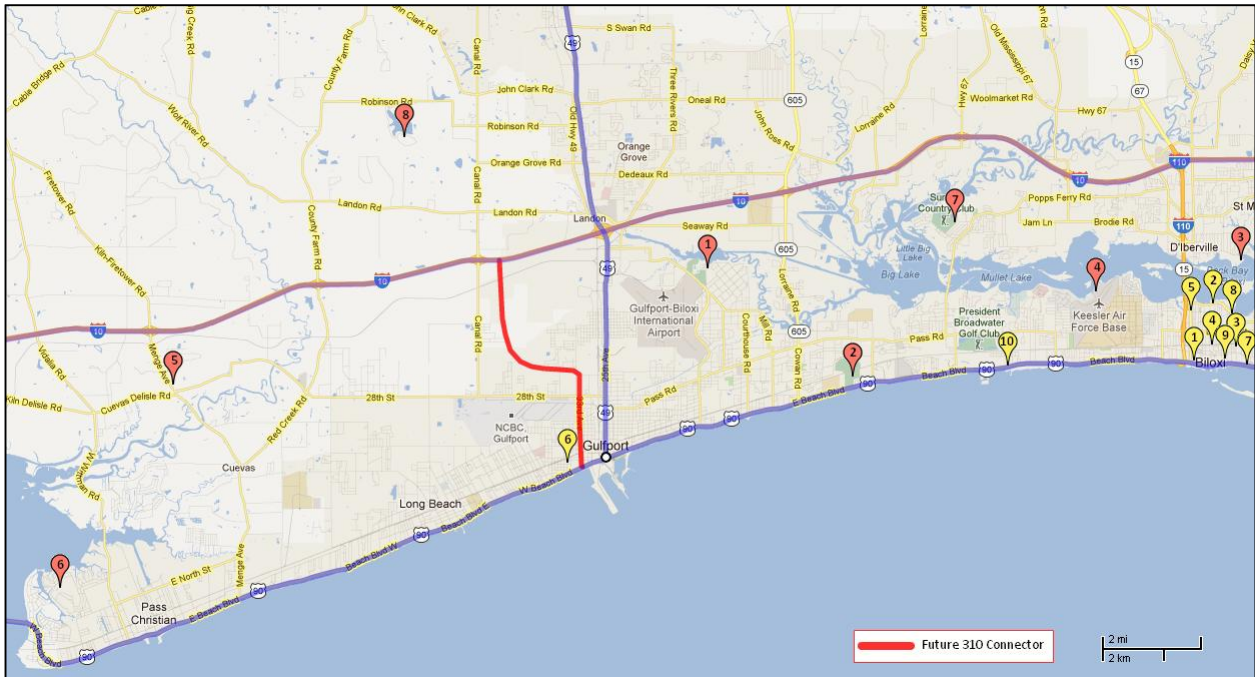

Source – Google Maps, Parsons Brinckerhoff

Tourism and leisure activities are a growth industry in the Gulfport region. It is likely that additional casino and resort development will center along the US-90 corridor regardless of Port expansion activity. However as with other industries, projecting sector and commercial growth within the Study Area is difficult due to the area's unique recent history. As with other industries, it is unlikely that even robust growth would be prohibited by the Port expansion due to the reasons outlined above.

### Charter Boats and Fishing Industry

There are over 50 employers in the charter boating and fishing industry within the Study Area, most of which are small and independent operators or sole proprietorships. As with commercial shrimp and fisheries, much of the commercial charter boat and fishing activity in the Study Area was erased after the hurricane but the industry has begun to return to the Mississippi coast. Exact employment figures for the charter boat and fishing industry are unavailable, but the recreational boating environment within Mississippi Sound is robust; recreational fisherman spent \$700,000 on fishing equipment and trips in 2009.

Charter boat and fishing outlets in the Study Area are concentrated along the small craft harbors that offer protective cover for boat storage. As seen in Figure 4, these businesses (as well as strictly recreational leisure boats) are predominantly found at marinas in Pass Christian and Long Beach to the west of the Port, and the Biloxi Small Craft Harbor and the Back Bay of Biloxi to the east. None of these locations are within close proximity to the port, nor do they compete for surface infrastructure with the

<sup>8</sup> See Appendix for list of businesses labeled in Figure 3

Port and are not expected to do so after Port expansion. In fact, access to the Biloxi Small Craft Harbor is achieved most easily by bypassing US-49 and instead using I-110.

Figure 4 Charter Boat and Fishing Employers within the Study Area

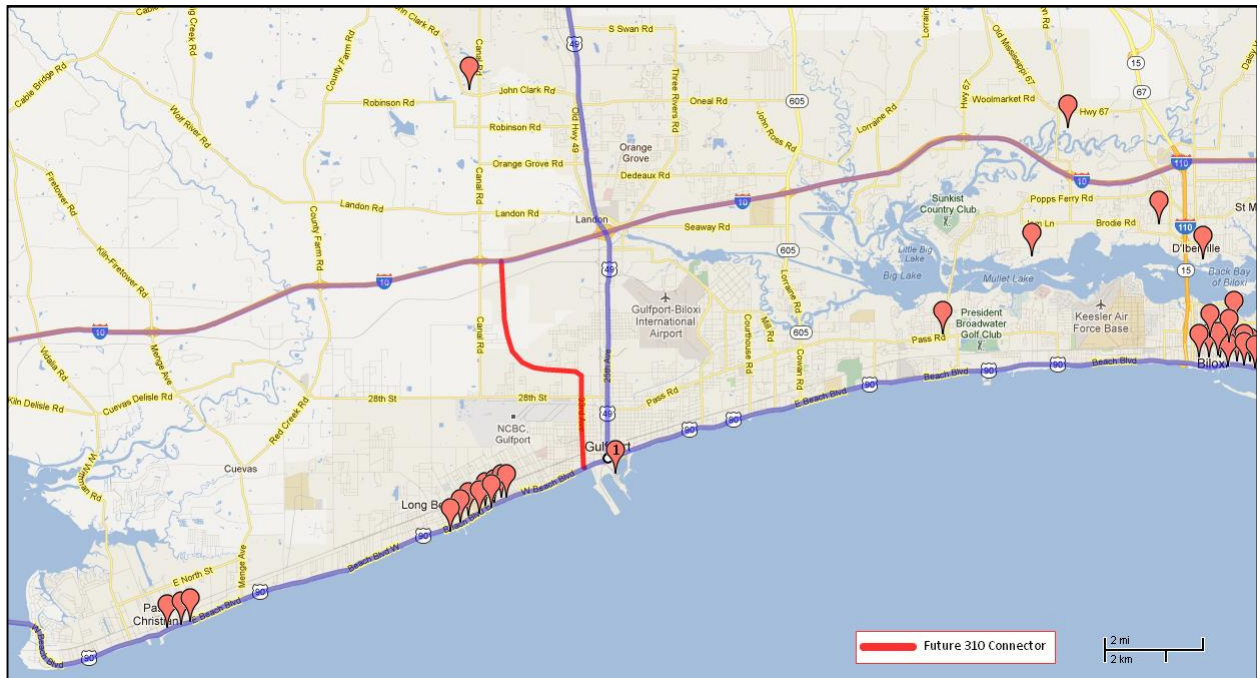

Source – Google Maps, Parsons Brinckerhoff

The one marina located directly at the Port of Gulfport, Bert Jones Yacht Harbor (marked “1” in Figure 4 above) shares a channel with the Port’s east terminal, but is sheltered by breakwaters and will remain protected post-expansion.

While again it is difficult to project near-term sector growth within the Study Area due to the unique circumstances surrounding damage done by Hurricane Katrina and the Deepwater Horizon oil spill, there is reason to believe marine tourism including charter boating and fishing will continue to increase as regional conditions improve. As with other sectors, it is unlikely that future growth will be prohibited by the Port expansion because the immediate area is suboptimal for small craft storage and there are other locations nearby offering more protected facilities.





## Appendix: Selected Businesses within Study Area

### Figure 2 Commercial Shrimp and Fishing

1. Crystal Seas Seafood LLC
2. David Gollott Seafood Co
3. Gulf Pride Enterprises
4. Quality Poultry and Seafood
5. North Bay Seafood, Inc
6. Custom Pack, Inc
7. Desporte and Sons, Inc
8. Seymour & Sons Seafood, Inc
9. Lion I Sea
10. Bully Rags LLC
11. Biloxi Shrimping Trip

### Figure 3 Leisure & Tourism

#### Casinos

1. Beau Rivage Resort and Casino
2. Boomtown Casino
3. Grand Biloxi Casino Hotel and Spa
4. Hard Rock Hotel and Casino
5. IP Casino Resort and Spa
6. Island View Casino Resort
7. Isle Casino Hotel Biloxi
8. Margaritaville Casino and Restaurant
9. Palace Casino Resort
10. Treasure Bay Casino and Hotel

#### Golf Courses

1. Bayou Vista Golf Course
2. Great Southern Golf Club
3. Gulf Hills Golf Club
4. Keesler Air Force – Bay Breeze Golf Course
5. Oaks Golf Club
6. Pass Christian Isles Golf Club
7. Sunkist Country Club and Golf Course
8. Windance Country Club



## **Appendix D**

### **STAR Center Ship Simulation 2010**





# STAR Center

**Simulation, Training, Assessment & Research**

2 West Dixie Highway • Dania Beach, Florida 33004  
TEL 954-921-7254 • 800-445-4522 • FAX 954-920-4268 • 800-431-8815  
www.star-center.com • email@star-center.com



April 14, 2011

## Gulfport Restoration Program 2010

### Overview

The port of Gulfport, Mississippi is in the process of port expansion. These plans include the expansion of container handling facilities at the port that will accommodate the ever increasing size of container vessels currently servicing the industry now and in the future. Expansion of the Panama Canal, now ongoing, will allow passage of even larger vessels that will require port facilities to provide increased support for these vessels. Construction is presently underway to increase and expand the container pier at Gulfport to provide adequate berthing facilities in support of these vessels. Of equal importance to a shore facility expansion, is the ability of vessels to transit into and out of these facilities via an entrance channel of sufficient width and depth to ensure safe passage.

Vessels accessing the port of Gulfport transit a dredged channel approximately 22 nautical miles in length, and requiring approximately two hours to transit. In order to determine/evaluate vessel access via this channel, STAR Center (STAR), located in Dania Beach, Florida was commissioned to conduct a simulator-based study of this channel and maneuvering area at the new pier on its 360 degree full-mission simulator. Because vessels vary widely in size (length, width and draft) and handling characteristics, normal practice in the evaluation of a navigation channel is to do so using a “design vessel”. A “design vessel” is usually selected that represents the type of vessel, in this case a Container vessel, with dimensions equal to the largest vessel expected to routinely transit this channel. The port of Gulfport selected a Panamax<sup>1</sup> Container vessel as “design vessel” for this study. The study was conducted during the period 6 thru 11 March, and 14 thru 18 March 2011 at STAR Center. This report summarizes the results and conclusions of that study.

### Participants

Two experienced pilots from the port of Gulfport participated in the simulations during separate sessions necessitated by their operational work schedules. They not only provided their expertise and local area knowledge of channel configurations, but also advised as to area winds, tides and local currents. The pilots’ active participation included operating the test vessels during all simulation runs. During this report, these participating pilots will be referred to as the “shiphandlers”. Our schedule provided 5

---

<sup>1</sup> Panamax. A vessel with a maximum beam of 32.2 meters. The maximum width allowable to transit the Panama Canal.



daily sessions for each pilot and the first day of the study, 6 March, was a day to validate the accuracy of the geographic database and for fine-tuning of local currents to ensure environmental conditions replicated actual conditions to the pilot's satisfaction.

STAR provided a Senior Researcher, simulator operator, simulator technician, a mate / helmsman, and a project facilitator to coordinate simulations, note results and conduct debriefings of participants at the end of each exercise.

## Simulator Models

### *Geographic database*

Database developers constructed the geographic database for the port of Gulfport, Mississippi containing the entrance channel and inner harbor. This database was constructed based on information gathered from NOAA Charts 11372 and 11373, Navigational publications, Tide and Current Tables and photographs obtained by internet sources such as Google Earth and Bing Maps. While channel depths were compiled from the NOAA charts, CH2M Hill, an engineering firm managing construction of the new pier, provided depth survey information for the inner channel from Ship Island northward to the harbor proper.

### *Hydrodynamic Vessel Models*

The ship response model of the Container vessel "Jutlandia" was provided to be used in simulations as the "design vessel". Container vessel "Jutlandia" was available in STAR's extensive library of vessel models, and was selected because it most closely replicated the type of vessel and dimensions requested by the client. Those requirements were a large Panamax container vessel (3,000 to 6,000 TEU) with a draft of approximately 10 meters. "Jutlandia" whose vessel particulars are outlined below had a draft of 10.5 meters. The agreed upon strategy was to add a +0.5 meter tidal offset to ensure the under-keel-clearance was accurate for a vessel with a 10 meter draft. Other vessels ultimately required for the study included the container vessels "Dania Exporter", and "White Bay". Tidal offset of +1.0 meter was used when operating "White Bay" to compensate for its 11 meter loaded draft, and charted depth (no tidal offset) was used for "Dania Exporter". Additionally, although not officially part of the study, the "Bellatrix" a small general cargo vessel was used on 6 March as part of the pilot validation of tidal currents in the area. Vessel particulars are listed in **Table 1 – Vessel Particulars** below.





**Table 1 – Vessel Particulars**

Vessel Name	Bellatrix	Jutlandia	Dania Exporter	White Bay
Condition	Loaded	Partly Loaded	Loaded	Loaded
Displacement	27,520	60,640	34,390	59,100
Wind Profile	N/A	7085 m <sup>2</sup>	4816 m <sup>2</sup>	6544 m <sup>2</sup>
LOA	159.6	294.1	198	254
Beam	24.9	32.2	32.2	32.2
Draft	9.1	10.5	9.5	11
Propulsion	Diesel Elec.	Slow Speed Diesel	Diesel Elec.	Diesel Elec.
Shaft HP	9,870	49,349	15,690	36,371
Propeller	1 (F) (CW)	1 (F) (CW)	1 (F) (CW)	1 (F) (CW)
Max Rudder	35	35	35	35

(F) Fixed Pitch Propeller, (CW) Clockwise direction, LOA, Beam, Draft in Meters.

## Environmental Conditions

### *Wind Direction and Velocity*

Winds in the area are normally from the eastern quadrant. Winds used in simulations were from the SE (southeast) and NE (northeast) at speeds ranging from calm to 20 knots and above. These winds, because of the general north/south direction of the entrance channel, act perpendicular, or slightly perpendicular to channel transit, and therefore, affect vessel steering and handling. Wind velocities of 25 knots were used in a small number of simulations.

### *Tidal Currents*

The range of tide in the Gulfport area is minimal, about 1.5 feet. Tidal currents therefore, are normally about 1 knot. Currents during simulations were described as Flood generally from an easterly direction and Ebb generally from a westerly direction. Current information supplied by the participating pilots during geographic database validation at the start of the project, identified an area east of Ship Island where currents often abruptly varied in direction and sometimes velocity. Modifications to the general current plan were incorporated in this area when both a Flood and Ebb current were used in the runs. Currents used in simulations were considered average velocities, and although currents, especially wind driven currents, may exceed the 1 knot limit used in simulations increased velocities were not considered. As with wind direction and velocity, currents, especially when perpendicular or nearly so, affect handling and steering of a transiting vessel.

The general directions of these currents are depicted in **Figure 1 – Ebb Current** and **Figure 2 – Flood Current** below.

**Figure 1 – Ebb Current**



**Figure 2 – Flood Current**

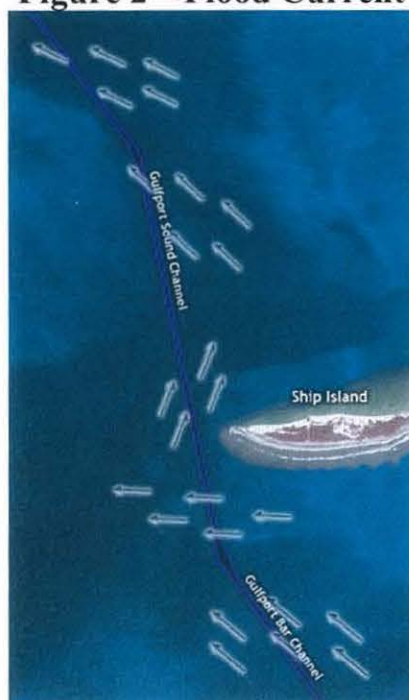





## **Channel Depths and Configuration**

The Gulfport harbor is entered via an approximately 22 nautical miles long, well marked, buoyed channel. This channel is divided into two segments. This report will refer to these channels as the outer channel (Gulfport Bar Channel) and the inner channel (Gulfport Sound Channel). Channel details are as follows:

The outer southern most channel is the Gulfport Bar channel. It is 122 meters (400 ft.) wide and 10 miles in length. Its depth is 11.6 meters (38 ft.).

The inner or northern most channel identified as the Gulfport Sound channel is 91.5 meters (300 ft.) wide, 11 meters (36 ft.) deep, and 10.6 miles in length. These channel widths and depths were incorporated in the geographic database for all simulation exercises. Tidal offsets, of none, 0.5 meters and 1.0 meters, addressed earlier in this report, were used to correct for vessel draft.

The only exception to this rule was in run numbers 8 thru 13 when a depth of 12.8 meters (42 ft.) in both channels was used briefly, to identify a depth in which it was surmised that “Jutlandia” could safely operate in all environmental conditions tested.

## **Tugboats**

The port of Gulfport has four (4) tugboats at its disposal to assist in docking and undocking vessels. These tugs are rated at 3,000 horsepower with single propeller propulsion. Two tugs are expected to assist arriving and departing container vessels during normal environmental conditions. These tugboats were controlled by the shiphandlers via VHF radio in simulations as they would in actual practice. Tugboat response was controlled by the simulator operator.

## **Testing Procedures**

The focus of our study was to determine whether a large container vessel could safely access the port of Gulfport via the existing channel during “normal” environmental conditions of wind and current. Additionally, because plans are moving ahead to modify the existing pier in the harbor proper, examine the effects of this pier expansion on vessel maneuver room, and evaluate the inclusion of a breakwater on the eastern side of the pier area. As a related item, examine the ability of the assist tugboats currently employed at the port, to provide adequate maneuver assistance to the arriving or departing vessel.

Preplanning of simulation runs for this project was completed prior to commencement of on-line simulations. The resulting Run Matrix would challenge the participating shiphandlers to operate the “Jutlandia” in the existing entrance channel both inbound / arriving and outbound / departing. Docking and undocking with tugboat assistance would be included in these exercises.

In simulations, as in actual practice, vessel transit from “sea buoy” to the berth at the pier requires at least 2 hours, the number of complete inbound and outbound runs were limited in number to conserve time on the simulator. Transits were then divided into shorter “legs” to save time, identify problem areas if any, and better use simulator time. Both shiphandlers would complete these simulations independently, under the same environmental conditions in order to garner their opinions and comments concerning each run and its practicality.



Our usual practice is to brief the shiphandler on the environmental conditions of wind and current for the upcoming run, identify the starting and end point, set the vessel on a course and starting speed agreeable to the shiphandler. At the conclusion of each run, the shiphandler is asked to fill out a Pilot's Run Evaluation form that solicits his opinions concerning the satisfaction with vessel handling, safety, difficulty etc. The forms are designed to solicit opinions while details of the just completed run are fresh in the minds of the shiphandler. A STAR Center facilitator notes simulator results and also notes important shiphandler verbal comments and reactions.

Problems and difficulties with the use of "Jutlandia" were encountered early in the project and an alternate Matrix and project strategy was devised in an attempt to provide a usable and practical solution to this challenge. A revised run matrix was implemented and many of the scheduled simulator runs from the previous Run Matrix were incorporated into the new Matrix.

Simulation run information and environmental conditions during each run are identified in **Figure 3 – Run Matrix** below.





**Figure 3 – Run Matrix**

Run #	Vessel	Transit Direction	Tidal Offset +	Wind Dir/Spd	Current Dir	Tugs	Start Point	End Point	Remarks
1	Jutlandia	Inbound	0.5	None	Slack	N/A	SB	11	
2	Jutlandia	Outbound	0.5	None	Slack	N/A	11	SB	
3	Jutlandia	Inbound	0.5	SE/15	Ebb	N/A	SB	11	
4	Jutlandia	Inbound	0.5	SE/15	Flood	N/A	22	35	Grounded
5	Jutlandia	Outbound	0.5	SE/15	Ebb	N/A	35	22	
6	Jutlandia	Inbound	0.5	None	Slack	N/A	22	35	
7	Jutlandia	Inbound	0.5	SE/15	Ebb	2	57	Berth	
8	Jutlandia	Inbound	*	SE/15	Flood	2	SB	Berth	
9	Jutlandia	Outbound	*	NE/20	Flood	N/A	11	SB	
10	Jutlandia	Outbound	*	NE/20	Ebb	N/A	35	22	
11	Jutlandia	Outbound	*	NE/20	Ebb	2	Berth	57	
12	Jutlandia	Inbound	*	None	Slack	2	57	Berth	
13	Jutlandia	Outbound	*	SE/15	Ebb	2	Berth	57	
14	Dania Exporter	Outbound	none	SE/20	Ebb	2	Berth	SB	
15	Dania Exporter	Inbound	none	None	Slack	2	57	Berth	
16	Dania Exporter	Outbound	none	None	Slack	N/A	35	22	
17	Dania Exporter	Outbound	none	NE/25	Flood	N/A	35	22	
18	Dania Exporter	Outbound	none	E/20	Flood	2	Berth	57	
19	Dania Exporter	Inbound	none	NE/25	Flood	N/A	22	35	
20	Dania Exporter	Outbound	none	NW/20	Slack	2	Berth	57	
21	Dania Exporter	Inbound	none	NE/25	Flood	2	57	Berth	
22	Dania Exporter	Inbound	none	SE/25	Ebb	N/A	22	35	
23	Dania Exporter	Outbound	none	NE/15	Slack	0	Berth	61	
24	Dania Exporter	Inbound	none	NE/10	Flood	2	SB	Berth	
25	Dania Exporter	Inbound	none	NE/20	Flood	2	57	Berth	
26	Dania Exporter	Inbound	none	NW/20	Slack	2	57	Berth	
27	Dania Exporter	Inbound	none	NW/30	Ebb	N/A	17	40	
28	Jutlandia	Inbound	0.5	SE/15	Ebb	N/A	SB	Berth	Grounded
29	Jutlandia	Inbound	0.5	SE/15	Ebb	N/A	30	Berth	Grounded
30	Jutlandia	Inbound	0.5	SE/15	Ebb	N/A	SB	Berth	
31	Jutlandia	Outbound	0.5	SE/15	Ebb	2	SB	Berth	Grounded
32	Jutlandia	Outbound	0.5	SE/15	Ebb	2	34	Berth	Grounded
33	Jutlandia	Outbound	0.5	SE/15	Ebb	N/A	31	SB	Grounded
34	White Bay	Inbound	1.0	SE/15	Ebb	N/A	24	35	Grounded
35	White Bay	Inbound	1.0	SE/15	Slack	N/A	29	57	
36	White Bay	Outbound	1.0	None	Slack	N/A	35	22	
37	White Bay	Outbound	1.0	SE/15	Ebb	N/A	11	SB	
38	Blank	Blank							
39	White Bay	Inbound	1.0	NE/20	Flood	N/A	22	35	Grounded
40	White Bay	Outbound	1.0	SE/15	Ebb	N/A	35	22	
41	White Bay	Outbound	1.0	SE/15	Slack	N/A	35	22	Redo #40
42	White Bay	Outbound	1.0	None	Slack	2	Berth	57	
43	White Bay	Outbound	1.0	None	Slack	N/A	11	SB	
44	White Bay	Inbound	1.0	None	Slack	2	57	Berth	
45	White Bay	Outbound	1.0	SE/15	Ebb	2	Berth	57	
46	White Bay	Inbound	1.0	SE/15	Ebb	2	57	Berth	
47	White Bay	Inbound	1.0	NE/20	Flood	2	57	Berth	
48	White Bay	Outbound	1.0	NE/15	Ebb	2	Berth	SB	Grounded
49	White Bay	Outbound	1.0	NE/15	Ebb	N/A	39	SB	cont. run #48
50	White Bay	Inbound	1.0	SE/15	Flood	N/A	22	35	
51	White Bay	Outbound	1.0	NE/25	Flood	1	Berth	57	
52	White Bay	Outbound	1.0	NE/25	Ebb	N/A	41	20	
53	Jutlandia	Inbound	0.5	SE/20	Ebb	N/A	SB	11	Grounded
54	Jutlandia	Inbound	0.5	NE/25	Slack	2	57	Berth	
55	Jutlandia	Outbound	0.5	NE/25	Flood	N/A	35	22	Grounded
56	Jutlandia	Outbound	0.5	NE/25	Flood	N/A	35	22	Grounded

Start and End Points - Numbers = buoy numbers. SB = Sea buoy.



## Simulation Results

### *“Jutlandia”*

The original Run Matrix (not included in this report) called for the exclusive use of “Jutlandia” as the “design vessel” with which to evaluate the channel and inner harbor new pier configuration. Although the shiphandler was comfortable with run results, when operating “Jutlandia” during the first seven runs, some difficulties were immediately apparent. With the exception of run #7, these exercises were conducted in the wider and deeper “outer channel” and even then steering control challenges were apparent. Even when a run was completed successfully, under-keel-clearance (UKC) of less than 0.8 meters at times, made vessel heading control difficult. The shiphandler elected to increase vessel speed in an attempt to mitigate these steering problems, only to lessen UKC to approximately 0.4 meters or less due to squat<sup>2</sup> effects. See **Figure 4 – Computed Squat “Jutlandia”** below. Wind and tidal current effects during these runs were kept to a minimum to non-existent in an effort to establish a baseline for vessel performance. Run number 4 resulted in a grounding exacerbated by the combination of squat and bank effects<sup>3</sup>. The vessel’s speed thru the water could be slowed to increase UKC, but this strategy would make the vessel more susceptible to wind and current effects and therefore, harder to maintain steerage. “Jutlandia” draft was effectively 10 meters plus 0.8 meters (computed squat @ 12 knots speed) totaling 10.8 meters, and operating in channels dredged to 11.6 and 11 meters respectively. The above factors would provide no margin of safety during transits by “Jutlandia”.

**Figure 4 - Computed Squat “Jutlandia”**

Speed Knots	Open Water Squat m	Confined Squat m
<b>2</b>	0.02	0.04
<b>3</b>	0.05	0.10
<b>4</b>	0.09	0.17
<b>5</b>	0.13	0.27
<b>6</b>	0.19	0.39
<b>7</b>	0.26	0.53
<b>8</b>	0.34	0.69
<b>9</b>	0.44	0.87
<b>10</b>	0.54	1.08
<b>11</b>	0.65	1.30
<b>12</b>	0.77	1.55
<b>13</b>	0.91	1.82

To continue testing of this vessel when insufficient channel depth was the major cause of concern seemed fruitless. The effects of mild to brisk winds, and tidal currents on the

<sup>2</sup> Squat – Increase in a vessels draft when speeds thru the water are increased.

<sup>3</sup> Bank Effects – Cushion and suction influences on a vessel caused by proximity of steep sides of a channel.





vessel to determine if channel width is adequate were cancelled because of this insufficient depth clearance. Communications with the client indicated that some idea of depth required to operate this vessel in the existing channel might be useful.

A one-day, very brief examination of access by "Jutlandia" with an arbitrary channel depth of 12.8 meters (42 feet) was conducted. Run numbers 8 thru 13 were conducted. Each of these runs was conducted without incident, and transits were successfully completed. Runs conducted at this 12.8 meter depth were meant to highlight the importance of channel depth. It has been our experience that in a narrow channel, when channel depth or UKC is more generous, narrow channels are less problematic. This fact is attributed to better steering/handling of a vessel in deeper water. In the case of our channel, especially the inner 91.5 meter wide channel, the combination of narrow channel and inadequate UKC make transits generally unsafe.

In order to solicit the opinions of the second participating shiphandler, during the second week of the project, "Jutlandia" was again examined. Run numbers 28 thru 33 and 53 thru 56 were conducted. Most runs ended in groundings and control problems due mainly to insufficient depths.

#### *"Dania Exporter"*

"Dania Exporter" was examined extensively during the first week of the project after "Jutlandia" runs indicated handling problems. Operation of "Dania Exporter" in the existing channel required no tidal offset as the vessel draft is 9.5 meters. Although it is also a panamax container vessel its length and therefore, its container carrying capacity are significantly reduced. A 9.5 meter draft will enable channel transits with little problems with UKC. This allowed us to observe its ability to maintain center channel during wind and current conditions normally experienced at the port.

As with all container vessels "Dania Exporter" presents a somewhat high wind profile due to the presence of containers stacked above deck. Although this vessel is smaller in length as well as less draft, and was not as large as the agreed upon "design vessel", testing it would yield useful information about channel capacity to support container vessel access. Simulation runs 14 thru 27 were conducted during various conditions of wind and current. Simulator exercises and participating shiphandler comments indicated that vessel performance during ebb or flood currents as well as winds from NE, SE, and E were not problematic. UKC during most runs were not less than 0.7 meters and when vessel speed was limited to approximately 10 knots, UKC was 1.0 meters or slightly more. The computed squat calculation for the vessel is +0.59 meters at a vessel speed of 10 knots.

Maneuvers inside the harbor proper presented few difficulties. Docking and undocking at the pier proved to have few difficulties as well. Two tugboats provided ample assistance, and in one instance, undocking from the new pier was accomplished without the use of tugs. The vessel docked both port side and starboard side to the berth.

#### *"White Bay"*

Because a combination of both vessel length and draft are major factors in determining the proper depth and width of the Gulfport channel, STAR Center made available "White Bay" a container vessel already in its library of vessel models. Its length of 254 meters,





40 meters shorter than “Jutlandia”, could be used to determine/quantify safe transit limitations in the existing channel. The only drawback was its loaded draft of 11 meters. As with the “Jutlandia”, a tidal offset was used to ensure UKC measurements and vessel handling characteristics were accurate. A tidal offset of +1.0 meters was used in all “White Bay” simulations, essentially giving it a draft of 10 meters. Run numbers 34 thru 52 were conducted using “White Bay”.

The participating shiphandler made every effort to keep vessel transit speeds to a minimum (about 10 knots) in an effort to maximize UKC, having already experienced the steering/grounding difficulties with the larger “Jutlandia”, also at 10 meter draft. See **Figure 5 – Computed squat “White Bay”** below.

**Figure 5 – Computed Squat “White Bay”**

Speed Knots	Open Water Squat m	Confined Squat m
2	0.03	0.05
3	0.06	0.12
4	0.11	0.21
5	0.17	0.34
6	0.24	0.48
7	0.33	0.66
8	0.43	0.86
9	0.54	1.09
10	0.67	1.34
11	0.81	1.62
12	0.96	1.93
13	1.13	2.26

It was decided to examine short “legs” of the channel to determine trouble spots or particularly challenging segments of the channel for the shiphandler. Some exercises were defined as repeat of the runs completed by “Jutlandia”, and some runs were at the request of the shiphandler. Docking and undocking at the existing pier as well as the new pier were successful, and tugboats were adequate in the opinion of the shiphandler. Vessel performance in the channel was about the same as with “Jutlandia”. The shorter in length “White Bay” handled only slightly better in the channel, shiphandler comments indicated that even if the exercise was completed successfully, there was no “margin for error”. The vessel performed better in the wider and deeper outer channel (Bar Channel) than the inner channel as expected. In the inner channel, vessel adherence to the center channel was important at all times. Should the vessel stray from the center of the channel, even if this strategy was deliberate, to combat the effects of wind or current, proximity to the bank of the channel taxed steering capabilities. Although not extensively repeated, no run from the sea buoy to the pier, or pier to sea buoy was completed without incident.

#### *Extended Pier and Vicinity*

The on-going construction of the container pier is extending the pier southward, providing additional berths for visiting vessels. Additionally, the 36 foot depth in the



harbor will be extended northward along this pier providing added maneuver room for vessels. Lastly, a breakwater will be installed and extended on the eastern side of the harbor to shelter this pier and maneuver area from possible waves and swell. Each of the vessels examined in this simulation project transited into and out of this “plan of the future” configuration of completed harbor design. Maneuver room provided by the extended northward dredging provided more than ample room to turn a vessel when arriving or departing. When however, an inbound / arriving vessel passes green marker number 61 at the channel end, the proximity of the extended breakwater, because of its proximity to that channel marker, restricts vessel clearance. This juncture is particularly important to the shiphandler as transitioning from channel transit speeds to maneuver minimums in this area requires slowing with ships engines and / or the assistance of tugboats alongside. Not only must the shiphandler clear this narrow area, but must concern himself with ensuring that the alongside tugboats have ample passing distances from the breakwater, and adequate maneuver room to assist the vessel as necessary. Both participating shiphandlers remarked negatively about this constriction, no matter which vessel was being operated. See **Figure 6 – Harbor Breakwater** below.

**Figure 6 – Harbor Breakwater**

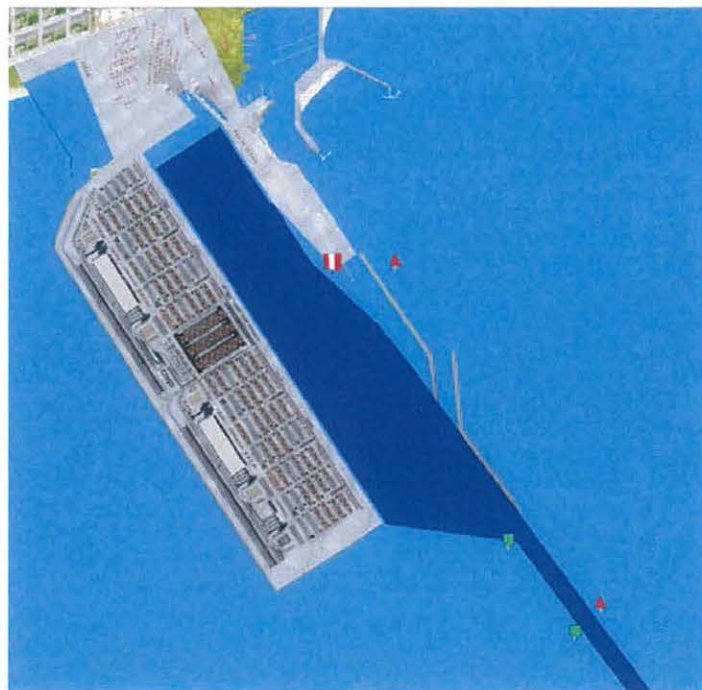





## CONCLUSIONS AND REMARKS

The obvious challenge for the shiphandler was the transits in the entrance channel. The approximately 22 nautical mile long entrance channel, consisting of two parts, the Bar channel and Sound channel, is designed at 122 and 91.5 meters in width, and 11.6 and 11 meters in depth respectively, and was expected to present the biggest challenge to access by the larger (length and draft) modern container vessels. The “design vessel” selected to examine this channel and harbor / new pier was from STAR’s library of vessel models. That vessel was the “Jutlandia”, selected because its relatively long length and minimum draft (partially loaded) might be able to successfully and safely access the harbor via the existing channel. If successful, it would be used to establish the normal and upper limits of conditions of wind and current which could be expected during transits.

### *“Jutlandia” and “White Bay”*

The “Jutlandia”, the focus of the study, was of necessity the first vessel tested. Problems with vessel control were noted with both the “Jutlandia” and “White Bay” early in the simulations. These steering control difficulties were the result of the lack of minimal to sufficient under-keel-clearance (UKC), and were compounded by the fact of transiting the narrow channels. Insufficient UKC can and does cause a vessel to “wander” across its intended course. Wind and tidal currents, especially when perpendicular, or nearly so, to the channel course, also may cause this effect. Container vessels with their large wind profile area are especially susceptible to wind influences, and all vessels are vulnerable to currents.

A brief description of the challenges facing the shiphandler trying to balance vessel speed vs. vessel control is presented here. Vessel squat, explained earlier, increases exponentially with vessel speed and is minimal to non-existent at speeds below 4-5 knots for most vessels. Vessel speed thru the water can provide increased steering control to combat the effects of wind and current when it is increased. When the effects of wind and current tend to set a vessel out of a channel for instance, the shiphandler might use course changes and increased speed to counter those effects. “Jutlandia” and “White Bay” were operated with a vessel draft for the purpose of simulation, at 10 meters. The effects of squat when vessels were operated at a 10 knot speed during transits increased this draft to 10.6 meters for “Jutlandia” and 10.7 meters for “White Bay”. In channels whose available depth is 11 and 11.6, UKC for safe vessel control is problematic. A vessel operated too slowly may be overly susceptible to wind and current, too fast and grounding in the channel is an increased possibility.

Channel widths are also an integral factor in vessel handling. During simulations vessel leeway<sup>4</sup>, at times, was about 3 degrees. This 3 degree leeway increased the “swept path” of “Jutlandia” and “White Bay” to 48 and 46 meters respectively. For “Jutlandia” this was 40% of the outer channel and 52% of the inner channel. “White Bay” used 38% of

---

<sup>4</sup> Leeway, crab angle, or drift angle – can be defined as the angular difference between the course steered and the course made good thru the water.



the outer channel and 50% of the inner. This increase essentially narrowed the available maneuver room in the channel, and proximity to the banks when course correcting.

The participating pilots, experienced and competent shiphandlers, used any and all of the strategies above to successfully complete the exercises. The Run Matrix presented in Figure 2 above, reported groundings during simulations involving both “Jutlandia” and “White Bay”. These groundings would cause the simulator to stop or “trip” forcing a reset and rerun. Groundings reported in the Matrix were those of sufficient magnitude to cause this “trip”. However, groundings that may have resulted in the vessel “bumping the bottom” during a run did not stop the simulation, but were none the less important groundings. Cases when “bumping the bottom” occurred were not infrequent. Even when the exercise was completed successfully, there was no “margin for error” demonstrated in simulation.

The “White Bay”, the shorter vessel, performed only slightly better in simulations than did the “Jutlandia”, however, it still had grounding and steering complications relating mainly to channel depth. Pilot Run Evaluations, which accompany this report, sometimes reflected an optimistic view of each exercise by the shiphandlers. In the case of the “Jutlandia” however, this opinion, when considered in hindsight, after completion of the entire project, Final Evaluations (also included) reported that both shiphandlers consider “Jutlandia” unsafe in the present channel. “White Bay” in the opinion of the shiphandler and expressed in the Final Evaluation, could be operated only during optimal environmental conditions. Since the ability of a container vessel to transit into and out of the port of Gulfport, during most conditions of tide, current, and wind, is important, the rating of “only during optimal conditions” is considered less than satisfactory.

#### ***“Dania Exporter”***

“Dania Exporter” was included in our testing of the port and entrance channel to provide some example of vessel size that is facilitated by the existing channel. The “Dania Exporter” is considerably shorter in length and more importantly, less draft (9.5 meters) than the “design vessel” or the “White Bay”. Its computed squat at a speed of 10 knots is 0.6 meters, giving it a 10.1 meter draft when transiting. Vessel performance during simulations was not problematic in either the outer or inner channels. Simulations included normal tidal currents and winds from different directions and velocities up to 30 knots. Shiphandler opinions both orally during debriefings and in writing in the Final Evaluation state that access by “Dania Exporter” is possible and safe. No problems were experienced when docking or undocking.

### **Recommendations**

Simulation has shown that the larger container vessels “Jutlandia” and “White Bay” cannot consistently and safely access the port of Gulfport via the channel as currently designed in conditions tested.

“Dania Exporter” can safely access the port of Gulfport via the channel as currently designed in conditions tested.





The 3,000 horsepower, single propeller tugboats used at the port and in simulations are ample to provide maneuver and docking/undocking assistance to all vessels tested.

The breakwater scheduled for inclusion at the harbor entrance north of marker number 61 can restrict vessel maneuvers at that critical juncture. Repositioning or removal of this breakwater is recommended.

## **Appendix E**

# **Dredged Material Management Plan**





# DREDGED MATERIAL MANAGEMENT PLAN PORT OF GULFPORT RESTORATION PROJECT

---

**Prepared for**

Mississippi State Port Authority – Port of Gulfport

**Prepared by**

Anchor QEA, LLC

9797 Timber Circle

Suite B

Daphne, Alabama 36527

**October 2015**



---

## TABLE OF CONTENTS

EXECUTIVE SUMMARY .....	ES-1
<b>1 INTRODUCTION .....</b>	<b>1</b>
1.1 Background.....	1
1.2 Project Description.....	1
1.2.1 West Pier Terminal Expansion.....	2
1.2.2 East Pier Terminal Expansion.....	2
1.2.3 North Harbor Fill Area .....	2
1.2.4 Turning Basin Expansion .....	3
1.2.5 Eastern Breakwater .....	3
1.3 Purpose and Scope.....	3
<b>2 EXISTING CONDITIONS.....</b>	<b>7</b>
2.1 Port of Gulfport.....	7
2.2 Anchorage Basin.....	7
2.3 Sound Channel .....	7
<b>3 DREDGING HISTORY .....</b>	<b>8</b>
3.1 Historical Dredging Data .....	8
<b>4 SHOALING ANALYSIS .....</b>	<b>11</b>
4.1 MsCIP Sediment Transport Analysis .....	11
4.2 Turning Basin Short-Term Shoaling Rates .....	12
4.3 Turning Basin Long-Term Shoaling Rates.....	14
4.4 Proposed Eastern Breakwater.....	19
<b>5 SEDIMENT CHARACTERIZATION.....</b>	<b>22</b>
5.1 General Sediment Geology in the Vicinity of the Project.....	22
5.2 Turning Basin and West Terminal Geotechnical Studies.....	22
5.2.1 USACE Soil Classification Data .....	23
5.2.2 USACE Sediment Grain Size Analysis.....	24
5.2.3 Proposed Berth 7 Turning Basin West Pier Expansion Sediment Borings .....	25
5.2.4 Turning Basin Expansion Sediment Study.....	25
5.3 Bulk Sediment Chemistry.....	26

5.3.1	2006 EA Study Report .....	26
5.3.2	2013 Anchor QEA Sampling Report .....	27
5.4	Site Water and Standard Elutriate Testing .....	27
5.4.1	2006 EA Study Report .....	27
5.4.2	2013 Anchor QEA Sampling Report .....	28
5.5	Bioassay Testing .....	29
5.6	Bioaccumulation.....	31
<b>6</b>	<b>PROPOSED DREDGING ACTIVITIES .....</b>	<b>36</b>
6.1	West and East Pier Terminal Expansion.....	36
6.2	Turning Basin .....	37
6.2.1	Turning Basin Expansion .....	37
6.2.2	Turning Basin and Berth Maintenance Dredging .....	37
<b>7</b>	<b>DREDGED MATERIAL PLACEMENT SCREENING REQUIREMENTS .....</b>	<b>39</b>
7.1	Beneficial Use Sediment Screening Criteria .....	39
7.2	Evaluation of Turning Basin Sediments.....	41
7.3	Evaluation of Sediments Adjacent to the Existing West Pier.....	41
7.4	Ocean Dredged Material Disposal Site Requirements .....	42
7.4.1	Tier 1 Evaluation Description.....	44
7.4.2	Expansion Project Tier 1 Data Evaluation .....	44
7.4.3	ODMDS Sediment Physical and Chemical Characteristics .....	45
7.4.4	Sediment Contamination Assessment .....	46
7.4.5	Additional ODMDS Sediment Testing.....	50
7.4.6	Expansion Project Tier 1 Data Evaluation Conclusions .....	51
<b>8</b>	<b>DREDGED MATERIAL PLACEMENT ALTERNATIVES .....</b>	<b>53</b>
8.1	Beneficial Use Sites .....	53
8.1.1	Mississippi Law .....	54
8.1.2	Beneficial Use Permitting and Additional Considerations .....	54
8.2	Available BU Sites and Capacities .....	55
8.3	Site Selection .....	58
8.3.1	Chandeleur Islands .....	59
8.3.1.1	Habitat Value .....	59
8.3.1.2	Site Stability .....	59

8.3.1.3	Sediment Transport .....	60
8.3.2	Biloxi March Complex – Northeastern Outlying Island .....	60
8.3.2.1	Habitat Value .....	60
8.3.2.2	Site Stability .....	60
8.3.2.3	Sediment Transport .....	61
8.3.3	Deer Island.....	61
8.3.3.1	Habitat Value .....	61
8.3.3.2	Site Stability .....	61
8.3.3.3	Sediment Transport .....	62
8.4	Ocean Sites Available for Material Placement .....	62
8.4.1	Pascagoula ODMDS.....	63
<b>9</b>	<b>PROGRAMMATIC ANALYSIS OF PLACEMENT ALTERNATIVES: NEW WORK</b>	
	<b>DREDGING.....</b>	<b>66</b>
9.1	Placement Alternatives.....	66
9.1.1	West Pier Terminal Expansion Fill .....	66
9.1.2	ODMDS Placement .....	67
9.1.3	BU Placement: Chandeleur Islands .....	67
9.1.4	BU Placement: BMC – Northeastern Outlying Island .....	68
9.2	Cost Assessment .....	69
9.3	Summary.....	71
<b>10</b>	<b>PROGRAMMATIC ANALYSIS OF PLACEMENT ALTERNATIVES: FUTURE</b>	
	<b>MAINTENANCE DREDGING.....</b>	<b>73</b>
10.1	Placement Alternatives.....	73
10.1.1	Thin-Layer Placement .....	73
10.1.2	Beneficial Use Placement.....	74
10.1.3	ODMDS Placement .....	75
10.2	Turning Basin and Berth Cost Assessment .....	76
10.3	Summary .....	76
<b>11</b>	<b>SUMMARY AND RECOMMENDATIONS.....</b>	<b>79</b>
11.1	New Work Dredging Summary.....	79
11.2	Turning Basin and Berth Maintenance Dredging Summary .....	80
11.3	Recommendations.....	85



11.3.1 Placement of New Work Dredging Material.....	85
11.3.2 Placement of Turning Basin and Berth Maintenance Dredging Material .....	86
<b>12 REFERENCES .....</b>	<b>87</b>

## List of Tables

Table 3-1 Port of Gulfport Historical Dredging Information from 1960 to 2011 .....	9
Table 4-1 USACE Conditions Survey Analysis (2006 to 2011) .....	13
Table 4-2 Gulfport Sound Channel Dredging Summary and Shoaling Rates <sup>1</sup> .....	16
Table 4-3 Gulfport Anchorage Basin Dredging Summary and Shoaling Rates <sup>1</sup> .....	17
Table 4-4 Gulfport Upper Sound Channel and Anchorage Basin Dredging and Shoaling Rate Summary <sup>1</sup> .....	18
Table 4-5 Gulfport Upper Sound Channel and Anchorage Basin Short-Term Shoaling Rates <sup>1</sup> .....	18
Table 5-1 USACE Historical Boring Log Data Analysis.....	23
Table 5-2 Sediment Characterization Grain Size Analyses (EA 2006) .....	24
Table 5-3 Sediment Characterization Grain Size Analyses (Thompson/URS 2003) .....	25
Table 5-4 Sediment Characterization Grain Size Analyses (Anchor QEA 2013).....	26
Table 5-5 Sediment Arsenic, Nickel, and Total PCBs Concentrations <sup>1,2</sup> .....	26
Table 5-6 Standard Elutriate Exceedance Matrix <sup>1</sup> .....	28
Table 7-1 Interim Protocols for Dredge Material Analysis for Beneficial Use <sup>1</sup> .....	40
Table 7-2 Bioassay 10-Day Test Results (Anchor QEA 2010b).....	42
Table 7-3 Sediment Analytical Results (Anchor QEA 2010b) .....	42
Table 7-4 ODMDS Physical Sediment Characteristics .....	46
Table 7-5 NRC Incident Summary .....	48
Table 7-6 Port of Gulfport Domestic and Foreign Cargo (2012).....	50
Table 8-1 Identified BU Project Sites <sup>1</sup> .....	57
Table 8-2 Ocean Disposal Data – Pascagoula ODMDS.....	64
Table 9-1 West and East Pier and Turning Basin Expansion Dredging Cost Summary .....	70
Table 10-1 Turning Basin and Berths Maintenance Dredging Cost Summary .....	76
Table 11-1 West and East Pier and Turning Basin Expansion Alternatives Screening Matrix <sup>1,2,3</sup> .....	82

Table 11-2 Maintenance Alternatives Screening Matrix<sup>1,2,3,4,5</sup> ..... 84

**List of Figures**

Figure 1-1 Port of Gulfport Location Map..... 5  
 Figure 1-2 Port of Gulfport Proposed Expansion..... 6  
 Figure 4-1 Cumulative Dredging Quantity Gulfport Anchorage Basin and Sound Channel  
 ..... 21  
 Figure 5-1 Distribution of Sediments in the Gulfport Ship Channel Area, Mississippi..... 32  
 Figure 5-2 Gulfport Geologic Cross-Section..... 33  
 Figure 5-3 Sediment Boring Locations..... 34  
 Figure 5-4 Turning Basin Dredging Units and Sampling Locations..... 37  
 Figure 8-1 ODMDS and Beneficial Use Locations ..... 65  
 Figure 9-1 Proposed Placement Locations ..... 72  
 Figure 10-1 Thin-Layer Placement Areas ..... 87

**List of Appendices**

Appendix A Port of Gulfport Maintenance Dredging Permit  
 Appendix B USEPA Envirofacts Reports

---

## LIST OF ACRONYMS AND ABBREVIATIONS

µg	microgram
AD	after dredge
Baker	Michael Baker Jr., Inc.
BD	before dredge
BMC	Biloxi Marsh Complex
BP	before placement
BU	beneficial use
BUG	Beneficial Use Group
CFR	Code of Federal Regulations
CY	cubic yard
D/A	disposal area
DEM	Digital Elevation Model
DMMP	Dredged Material Management Plan
DU	dredge unit
EA	EA Engineering, Science, and Technology
EC <sub>50</sub>	median effective (sub-lethal) concentration
EIS	Environmental Impact Statement
ERM	effects range median
FNC	Federal Navigation Channel
GIWW	Gulf Intracoastal Waterway
kg	kilogram
KHz	kilohertz
L	liter
LC <sub>50</sub>	median lethal concentration
LF	linear foot
LPC	limiting permissible concentration
MCY	million cubic yards
MDMR	Mississippi Department of Marine Resources
mg	milligram

MLLW	mean lower low water
MPRSA	Marine Protection Research Sanctuary Act
MRL	method reporting level
MsCIP	Mississippi Coastal Improvement Program
MSL	mean sea level
MSPA	Mississippi State Port Authority
NAVD88	North American Vertical Datum of 1988
NEPA	National Environmental Policy Act
ng	nanogram
NOAA	National Oceanic and Atmospheric Administration
NOI	Notice of Intent
NRC	National Response Center
NWR	National Wildlife Refuge
O&M	Operations and Maintenance
ODMDS	Ocean Dredged Material Disposal Site
PAH	polycyclic aromatic hydrocarbon
PCB	polychlorinated biphenyl
PEL	probable effects level
PGRP, Program	Port of Gulfport Restoration Program
Plan	Master Plan for the Beneficial Use of Dredged Material for Coastal Mississippi
Port	Port of Gulfport
Project	Port of Gulfport Expansion Project
SERIM	Southeast Regional Implementation Manual
SMMP	Site Management and Monitoring Plan
SP	solid phase
SPP	suspended particulate phase
STFATE	Short-Term FATE
STWAVE	STeady-State Spectral WAVE
SVOC	semi-volatile organic compound
TBS	T. Baker Smith

TEL	threshold effects level
TEU	Twenty-foot Equivalent Unit
Thompson	Thompson Engineering, Inc.
TOC	total organic carbon
TPH	total petroleum hydrocarbon
URS	URS Corporation
USACE	U.S. Army Corps of Engineers
USCS	Unified Soil Classification System
USEPA	U.S. Environmental Protection Agency
USFDA	U.S. Food and Drug Administration
USFWS	U.S. Fish and Wildlife Service
Weeks	Weeks Marine, Inc.
WQC	water quality criteria

---

## EXECUTIVE SUMMARY

The Dredged Material Management Plan (DMMP) is being developed in conjunction with an Environmental Impact Statement (EIS) for the Port of Gulfport (Port) Expansion Project (the Project). The Project proposes to expand the existing West Pier (155 acres) and East Pier (14.5 acres) facilities, which would provide additional operational areas for future concessions at the Port. The West Pier expanded areas would be constructed to +25 feet North American Vertical Datum of 1988 (NAVD88). The remaining areas, including a North Harbor Fill area, would be constructed to an elevation of +12 to +14 feet NAVD88. To accommodate the increased traffic and larger vessels associated with expanding the Port, the Project also includes creation of a Turning Basin adjacent to the existing Anchorage Basin and the expanded West Pier. Finally, a breakwater may also be constructed along the eastern side of the existing channel to provide additional storm protection for the expanded facilities.

This DMMP evaluates the placement options for the dredged material from the expansion of the piers, construction of the Turning Basin, and maintenance dredging events. The Project will require removal and placement of approximately 7.51 million cubic yards (MCY) of sediment for the expansion of the piers and the creation of the Turning Basin.

The DMMP evaluates several dredged material placement alternatives for the Project. One alternative is to use the dredged material as fill for the West Pier Terminal Expansion. Another option is to place the materials in an existing U.S. Environmental Protection Agency (USEPA) designated Ocean Dredged Material Disposal Site (ODMDS). At the time of this DMMP, there is one available USEPA-designated ODMDS—the Pascagoula ODMDS. The Beneficial Use (BU) alternatives include placement at the Chandeleur Islands and Biloxi Marsh Complex (BMC) in St. Bernard Parish, Louisiana, for marsh and shoreline restoration and habitat enhancement.

The DMMP also includes placement alternatives for the material from the maintenance dredging of the proposed Turning Basin and West Pier, North Harbor, and East Pier berthing area. The estimated 30-year maintenance quantity is between 14.6 and 40.2 MCY. Thin-layer placement in the open-water sites to the west of the Federal Navigation Channel (FNC)



and placement in the Pascagoula ODMDS are two alternatives evaluated for the maintenance dredged material. Deer Island, which was one of the sites identified in the State of Mississippi BU Master Plan, was also evaluated as a placement option for the Turning Basin and West Pier, North Harbor, and East Pier berthing area maintenance dredged material.

Dredged material placement sites are evaluated based on the cost associated with dredging; environmental consequences; transport; and the available or estimated capacity. For the West and East Pier and the Turning Basin improvements, the BMC in St. Bernard Parish, Louisiana, is the recommended placement site for the dredged material. As of the date of this DMMP, the Mississippi Department of Marine Resources is in beginning stages of developing the BMC permit as a beneficial use site for placement of the dredged materials. Thin-layer placement within the Mississippi Sound is the recommended alternative for the Turning Basin and West Pier, North Harbor, and East Pier berthing area maintenance dredging.

---

## **1 INTRODUCTION**

The Dredged Material Management Plan (DMMP) is being developed in conjunction with an Environmental Impact Statement (EIS) for the Port of Gulfport (Port) Expansion Project (the Project). The DMMP will evaluate the management alternatives for the dredged material from the construction and maintenance of the Project. As outlined in the draft EIS, the proposed Project includes increasing the footprint of the existing West Pier, East Pier, North Harbor, and the Anchorage Basin.

### **1.1 Background**

The Port of Gulfport, located on the Gulf of Mexico in Harrison County, Mississippi, is approximately 5 miles south of Interstate 10 (I-10; Figure 1-1). The current operational facility is approximately 369 acres and was constructed in 1902 as part of the Gulf and Ship Island Railroad venture.

In 1998, the U.S. Army Corps of Engineers (USACE) issued a permit (Permit Number MS96-02828-U) to the Port for an 84-acre expansion to the existing West Pier Terminal. During construction of the first two phases of this project, Hurricane Katrina made landfall (August 29, 2005) on the Mississippi Gulf Coast. The storm significantly damaged the Port's existing infrastructure and the West Pier Expansion. Through available Community Development Block Grant (CDBG) funds, the Port has initiated the Port of Gulfport Restoration Program (PGRP, the Program), which aims to restore the facility to its pre-Katrina status and complete the renovations interrupted by the storm.

### **1.2 Project Description**

On March 11, 2011, the USACE Mobile District filed a Notice of Intent (NOI), in accordance with the National Environmental Policy Act (NEPA) process, to develop an EIS for the Project. The Project, as described in the NOI (SAM-2009-1768-DMY, issued April 16, 2010), has been altered from its initial scope. Initially, approximately 700 acres of open water in the Mississippi Sound were proposed to be filled to expand the collective footprint of the Port. The modified Project scope entails filling a smaller footprint of approximately 200 acres. The reduced footprint decreases the overall amount of fill necessary for expansion and will no longer impact the existing Anchorage Basin or Federal Navigation Channel (FNC).

In addition, the proposed Project includes the construction of wharfs, bulkheads, terminal facilities, container storage areas, intermodal container transfer facilities, infrastructure and a breakwater, and dredging and dredged material placement (Federal Register 2011). The expanded terminal footprint will have a finished elevation of +25 North American Vertical Datum of 1988 (NAVD88) at the West Pier and +12 to +14 feet NAVD88 in the remaining areas to mitigate impacts to the Port's infrastructure. The total Project will require removal and placement of 7.51 million cubic yards (MCY) of sediment. Sections 1.2.1 to 1.2.5 provide a more detailed description the project components.

### **1.2.1 West Pier Terminal Expansion**

The goal of the West Pier Terminal Expansion is to develop a multiuse concession that adjoins the southern end of the existing West Pier. The proposed expansion area will extend the West Pier footprint approximately 3,600 linear feet (LF), adding approximately 155 acres to the existing facility (Figure 1-2). The operations, storage, and berthing capacity of the expanded area will result in a potential through-put capacity of 1.7 million Twenty-foot Equivalent Units (TEUs) per year (CH2M HILL 2010b). The dredging for the West Pier includes removal of soft sediments prior to fill placement and 30-year maintenance dredging of the proposed berths.

### **1.2.2 East Pier Terminal Expansion**

The East Pier Terminal Expansion proposes to add approximately 14.5 acres (Figure 1-2) for rail operations and additional warehouse storage space. An additional berth is proposed on the southwestern corner of the East Pier Expansion. The dredging for the East Pier includes removal of soft sediments prior to fill placement and 30-year maintenance dredging of the proposed berth.

### **1.2.3 North Harbor Fill Area**

The Project proposes to fill approximately 9 acres of the former berth of the Copa Casino vessel in the North Harbor (Figure 1-2). The proposed design also includes construction of a new berthing area. The dredging for the North Harbor includes berth construction and future maintenance dredging.

#### **1.2.4 Turning Basin Expansion**

The Turning Basin will support the increased traffic resulting from the West Pier Terminal Expansion. The proposed 85-acre Turning Basin is adjacent to the existing Anchorage Basin (Figure 1-2). The Turning Basin would be dredged to a depth of -36 feet mean lower low water (MLLW) plus 2 feet of advance maintenance and 2 feet of allowable overdepth. The DMMP evaluation includes the dredging associated with the Turning Basin Expansion and maintenance dredging.

#### **1.2.5 Eastern Breakwater**

A proposed breakwater along the eastern side of the FNC will provide storm protection to the Project berthing areas. The proposed 4,000 LF breakwater footprint (Figure 1-2) covers approximately 18 acres. A breach mid-way along the alignment of the structure will allow shallow-draft access to and from the FNC to the Bert Jones Yacht basin. Several breakwater alignments have been analyzed as part of the Project (Baker 2011) and are discussed in Section 4.4.

### **1.3 Purpose and Scope**

The purpose of this DMMP is to evaluate the best material management alternatives for the placement of material dredged from the construction and maintenance of the Expansion Project. The main goals of the DMMP are as follows:

- Determine the dredging history for the Port
- Review sediment transport trends and shoaling rates
- Calculate volumes for dredging the West Pier, East Pier, and Turning Basin Expansion alternatives
- Determine the sediment characteristics of the proposed dredge material
- Determine Beneficial Use (BU) criteria and alternatives
- Review the screening requirements and capacities for the existing U.S. Environmental Protection Agency (USEPA) Ocean Dredged Material Disposal Site (ODMDS)
- Develop and analyze alternatives for dredged material placement alternatives

For this DMMP, the dredged material placement alternative analysis is based on availability, placement logistics, and costs. A global assessment of the environmental impacts for each

alternative is beyond the scope of this DMMP. Such an analysis is relevant and included as part of an EIS to assess the effects of the proposed alternatives.

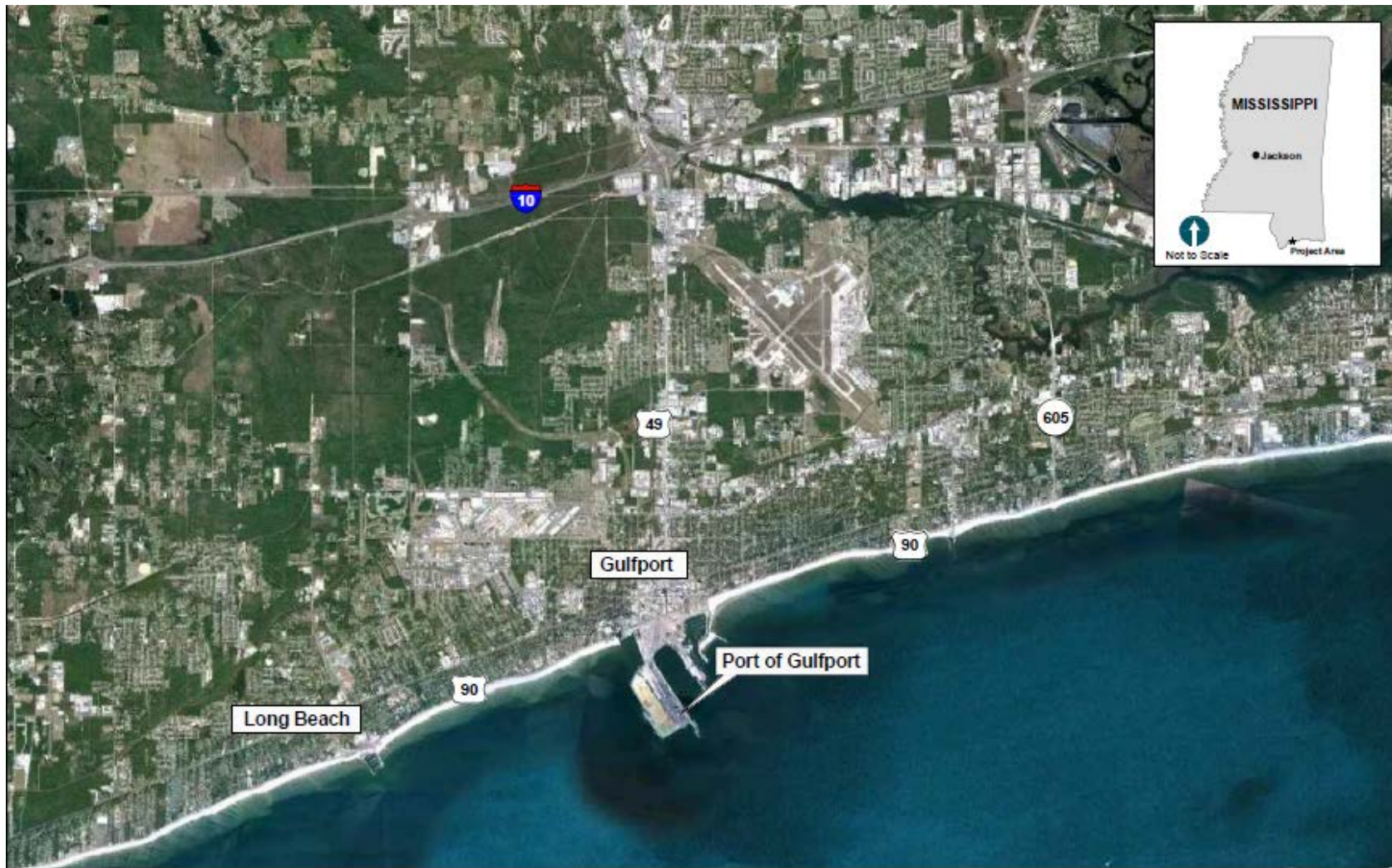

**Figure 1-1**  
**Port of Gulfport Location Map**



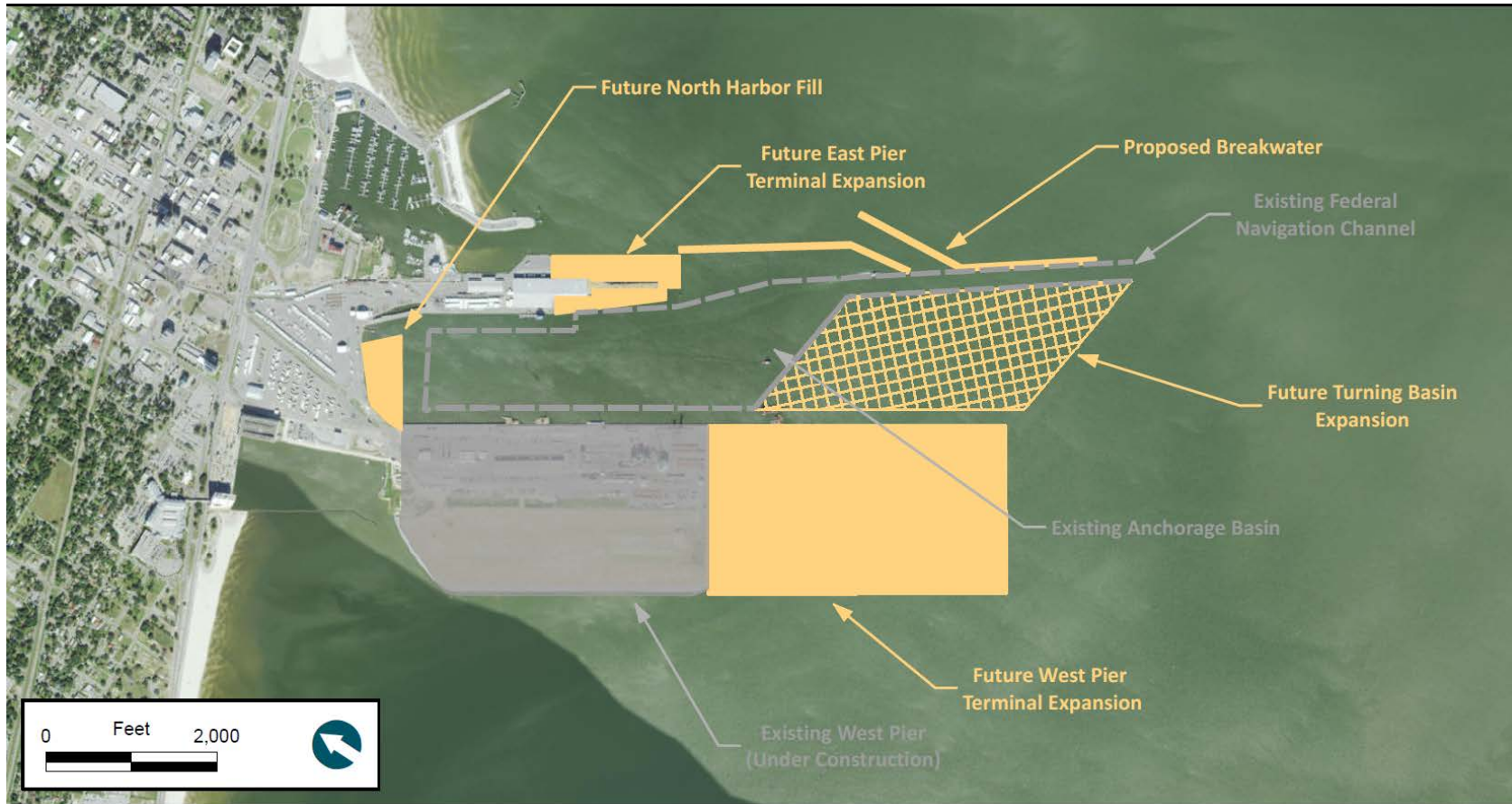

**Figure 1-2**  
**Port of Gulfport Proposed Expansion**



---

## **2 EXISTING CONDITIONS**

### **2.1 Port of Gulfport**

The Port of Gulfport consists of the West and East Pier Terminals, and North Harbor. Facilities at the Port include rail, storage buildings, open container storage, dockside berths, off dock storage, open bulk and break-bulk storage, and a container freight station (MSPA website 2015).

### **2.2 Anchorage Basin**

The Anchorage Basin extends from station 0+00 at the north to the entrance of the Sound Channel at station 50+75 and is divided into north and south sections. The northern section of the Anchorage Basin (station 0+00 to 15+49) has an authorized -32 feet MLLW maintenance depth and a width of 1,100 feet. The southern end (station 15+49 to 50+75) is authorized to be maintained at a depth of -36 feet MLLW with varying widths to accommodate the entrance at the Sound Channel; it is 1,360 feet at its widest point (USACE 2011).

### **2.3 Sound Channel**

The 11-mile Sound Channel (station 50+75 to 610+34) of the FNC extends southward from the Port's Anchorage Basin and connects the Port with the deeper and wider Bar Channel. The Sound Channel segment is maintained at a depth of -36 feet MLLW and a width of 300 feet.

---

### 3 DREDGING HISTORY

To assess the shoaling rates for the proposed Turning Basin and West Pier, North Harbor, and East Pier berthing areas maintenance dredging, a comprehensive dredging history for the USACE Anchorage Basin and Northern Sound Channels were developed for this DMMP.

The dredging history assessment for the Turning Basin Expansion includes an evaluation of all USACE dredging contracts from 1960 to 2011. The primary sources included the cutterhead history cards (USACE 2011). The dredging history cards provide characteristic site data for each dredging event at the Port, including, but not limited to:

- Location
- Production rates
- Cubic yards (CY; net and gross)
- Dredged depth
- Disposal areas (D/A)

#### 3.1 Historical Dredging Data

Table 3-1 provides a summary of the USACE historical dredging data from 1960 to 2011 for the Gulfport Sound Channel and the Anchorage Basin. Some of the USACE dredging events included removing material from the Bar and Gulf Channel segments. The USACE records did not contain any dredging history for the Port berths.

As shown in Table 3-1, the USACE has dredged the Sound Channel almost every year since 1960. From 1992 to 1993, the USACE deepened the channel to -36 feet MLLW (Sound Channel) and -40 feet MLLW (Bar and Gulf Channels), removing approximately 19 MCY of material from the channel. The last maintenance dredging event for the Anchorage Basin and upper Sound Channel was completed in March 2015. The USACE contractor removed 562,000 CY total from the 5,075-foot-long Anchorage Basin, with more than 324,000 CY dredged from the southern 1,650 feet of the area where the basin widens from 300 feet to 750 feet. They dredged 136,000 CY in the northern 2,025 feet of the sound channel. Due to funding, the USACE was unable to dredge the Anchorage Basin and the upper Sound to maintenance depths. Therefore, the 2015 dredging volumes were not included in the Section 4 shoaling analysis calculations.

The maintenance dredging of the Port facilities is currently addressed in the September 11, 2009, USACE permit SAM-2009-00433-JBM (USACE 2009b; Appendix A). The permit expires on August 7, 2019 and includes maintenance dredging for the berths along the north and south harbor, the commercial small craft harbor, and the entrance channel. The Port facility estimated cumulative maintenance dredging quantity for the 10-year period is 200,000 CY.

**Table 3-1**  
**Port of Gulfport Historical Dredging Information from 1960 to 2011**

Dredging Dates		Gross Yardage (CY)	Dredging Location
Start	Finish		
March 1960	May 1960	991,471	Channel & Basin
May 1961	June 1961	824,955	Channel & Basin
October 1962	March 1963	8,793,914	Channel & Basin
January 1964	February 1964	3,458,638	Channel
January 1965	February 1965	4,340,836	Channel
December 1965	December 1965	1,658,042	Channel
October 1966	December 1966	4,223,603	Channel & Basin
December 1967	February 1968	5,065,915	Channel & Basin
June 1969	August 1969	5,931,005	Channel & Basin
July 1970	October 1970	4,914,935	Channel & Ship Island Point
August 1971	November 1971	5,081,368	Channel & Basin
February 1973	April 1973	3,909,741	Channel & Basin
June 1974	October 1974	5,212,956	Channel & Basin
March 1976	March 1976	4,440,132	Channel & Basin
May 1977	July 1977	3,225,888	Channel
December 1978	February 1979	2,570,847	Channel & Basin
January 1980	April 1980	3,192,053	Channel, Basin, Ship Island Point, & Borrow Area
December 1980	February 1981	4,351,263	Channel & Basin
August 1982	November 1982	5,085,470	Channel, Basin, Ship Island Point, & Bar Channel
October 1983	December 1983	5,296,500	Channel, Basin, & Ship Island Point
March 1985	June 1985	4,536,886	Channel, Basin, & Small Craft Harbor
September 1986	December 1986	5,062,411	Channel, Basin, Ship Island Point, & Bar Channel
April 1988	May 1988	5,975,889	Channel, Basin, & Bar Channel
July 1988	November 1988		
August 1991	October 1991	4,659,961	Channel, Basin, Ship Island Point

Dredging Dates		Gross Yardage (CY)	Dredging Location
Start	Finish		
May 1992	December 1993	18,899,845	Channel Deepening
June 1995	July 1995	2,469,212	Channel & Ship Island Point
September 1996	October 1996	9,073,044	Channel, Basin, Ship Island Point
November 1998	December 1998	4,883,333	Channel & Basin
January 2000	March 2000	2,909,800	Channel & Basin
July 2001	October 2001	3,030,326	Channel
January 2003	April 2003	4,249,413	Channel
July 2004	November 2004	2,739,041	Channel & Basin
November 2005	February 2006	2,157,483	Channel & Basin
September 2007	November 2007	5,105,006	Channel
March 2009	August 2009	5,171,419	Channel
April 2009	August 2009	2,145,713	Basin
March 2011	July 2011	1,881,000	Channel & Basin
March 2015	March 2015	698,000	Basin & Upper Sound Channel

---

## 4 SHOALING ANALYSIS

Shoaling was analyzed to estimate the dredging frequency of the proposed Turning Basin. Sediment transport rates in the Mississippi Sound region determine the shoaling rates and dredging frequency of the Southern Anchorage Basin and Sound Channel. The USACE (1976) attributes the accumulation of silts and muds in the area of the Port to the relatively low-energy environment along the Mississippi Sound, which receives suspended and longshore sediment loads from the Mobile and the Pascagoula River basins. Sediments are deposited in the Sound as a result of the following two processes: 1) discharge from the Pearl River (easterly flow direction) and 2) flood tides from the Gulf of Mexico. The processes reduce the overall energy of the predominate east-to-west current and resupply the Mississippi Sound with sediments from coastal runoff (USACE 1976).

A sediment transport analysis was performed for the USACE as part of the Mississippi Coastal Improvement Program (MsCIP) to quantify a regional sediment budget for the Mississippi Gulf Coast. The analysis presents a general assessment of the nearshore sediment transport rates along the Harrison County shoreline but does not address sediment transport within the Mississippi Sound (Rosati et al. 2009). In an effort to present localized shoaling rates for the site-specific areas of the Project, short- and long-term shoaling rates developed from the USACE FNC condition surveys and dredging history cards (Section 3) supplement the information presented in the sediment transport analysis. The history cards indicate a general east-to-west deposition into the channel. This section also includes a discussion on the effects of the proposed breakwater on anticipated shoaling in the Project area.

### 4.1 MsCIP Sediment Transport Analysis

The MsCIP sediment transport analysis includes a comprehensive evaluation of the current coastal conditions and processes (Rosati et al. 2009). Comprehensive modeling was performed as part of the analysis to determine the typical annual wave climate along the Mississippi Gulf Coast shoreline and to develop longshore sediment transport rates. The model results were then used to calculate a sediment budget for the coastline areas. The analysis covers 135 years and indicates the following (Rosati et al. 2009):

- The general longshore sediment transport direction for the Mississippi mainland coast is east to west except in areas with high amounts of vegetation or manmade structures that alter the direction and intensity of the longshore transport.
- The long-term shoreline change (retreat and loss) along the Harrison County beach is 0.7 feet per year.
- The Harrison County shoreline is a stable system that is not prone to accretion or erosion.

The analysis did not investigate the local deposition of sediment along the Anchorage Basin or the FNC. For the DMMP shoaling analysis, the Anchorage Basin and the Sound Channel are assumed to be stable and steady state areas that do not experience erosion.

## 4.2 Turning Basin Short-Term Shoaling Rates

As part of the routine maintenance of the FNC, the USACE performs annual and sometimes semi-annual channel condition surveys to evaluate navigation conditions between dredging events. To determine the short-term shoaling rates for the proposed Turning Basin, an analysis of the 2006 to 2011 survey datasets was conducted for sections of the Northern Navigation Sound Channel (lower Anchorage Basin and upper Sound Channel). The period of analysis represents conditions immediately following Hurricane Katrina in 2005.

The USACE provided 2006 to 2011 condition survey data for the lower Anchorage Basin (27+00 to 50+74) and the upper Sound Channel (50+74 to 70+00). Some of the surveys provided by the USACE were performed as check surveys during regular maintenance dredging events; however, these datasets, identified by cross-referencing the collection date and the dredging event dates, are not used in this analysis. In addition to the USACE surveys, the 2011 maintenance dredging contractor, Weeks Marine, Inc. (Weeks), provided the after dredge (AD) survey data for the areas listed above.

The Weeks AD survey was used as a baseline condition for the short-term shoaling analysis. Each interim condition survey was compared to the “typical” AD survey cross section. The difference between the surveys was reported as a shoaling volume in CY. The shoaling rate (CY/Month) is the quotient of the dredged quantity and the time elapsed (months) between



the dredging and survey events. The calculated shoaling rates were then divided by the total dredging length to provide a shoaling rate per LF as follows: CY/Month/LF. Once the results for each dredging event were calculated, they were averaged to formulate the short-term shoaling rates in Table 4-1. To complete the analysis, it was assumed Hurricane Katrina introduced large volumes of sediment into the channel and elevated the shoaling volumes. This assumption can be validated by reviewing the dredging rates for the Anchorage Basin and Sound Channel pre- and post-Katrina. As shown in Figure 4-1, the pre-Katrina dredging rate was approximately 2,689,000 CY/year, and the post-Katrina dredging rate is greater than 1.5 times this rate at 4,072,000 CY/year. These increased dredging rates should therefore be considered when comparing the short-term shoaling rates presented in this section with the long-term rates presented in Section 4.3.

A total of 22 surveys were analyzed between channel stations 27+00 to 70+00 within the Project area: eight Anchorage Basin surveys and 14 Sound Channel surveys. Based on the results shown in Table 4-1, the Anchorage Basin and the Sound Channel experience localized sediment accumulation over time. The results do not contradict the analyses completed as part of the MsCIP studies (Rosati et al. 2009), as the Anchorage Basin and Sound Channel were grouped as an entire system, and the analyses considered the effects of dredging.

**Table 4-1**  
**USACE Conditions Survey Analysis (2006 to 2011)**

Value	Location	
	Anchorage Basin	Sound Channel
Average Time Between Surveys (MONTH)	4.7	4.7
Net Sediment Shoaling Volume (CY)	128,108	28,932
Average Shoaling Rate (CY/MONTH/LF)	1.2	5.8

One item to note is that condition survey data in the Project areas of the existing Sound Channel are subject to variability due to a fluid mud layer, which can become resuspended in the water column as a result of vessel movement, winds, and tides (McAnally et al. 2007a,

2007b; USACE 2002, 2009a). Additionally, acoustic surveying methods are dependent on several factors, including the transducer frequency (24 versus 200 kilohertz [KHz]; USACE 2002). Resuspended fluid mud material could induce backscatter and indicate a “false bottom,” which causes large inaccuracies when determining the bathymetry along a survey transect (McAnally et al. 2007b; Welp 2011<sup>1</sup>) and can ultimately affect the calculation of cumulative shoaling volumes. The effect on navigation cannot be completely assessed, as the USACE and vessel pilots have not quantified or defined “navigable” depth resulting from fluid mud impacts. For the shoaling rate analysis comparison of the before dredging (BD), AD, and condition surveys, it was assumed that all material, including any fluid mud, was removed from the dredging prism. Therefore, there was no need to increase the dredging quantities and shoaling rates to account for fluid mud.

### 4.3 Turning Basin Long-Term Shoaling Rates

The dredging dates and quantities from the Anchorage Basin and Sound Channel dredging history (Section 3) were used to estimate the long-term shoaling rates. The analysis includes all 16 maintenance dredging events from 1995 to 2009 channel deepening (ten events for the Sound Channel and six events for the Anchorage Basin).

Tables 4-2 and 4-3 summarize the results of the long-term shoaling analysis for the Gulfport Sound Channel and the Anchorage Basin. The large volume from the 1996 dredging event in Table 4-2 appears to be due to Hurricane Opal (1995). Figure 4-1 provides the cumulative dredging quantity for the Anchorage Basin and Sound Channel during this time period. The shoaling rate (CY/Month) is the quotient of the dredge quantity and the time elapsed (months) between the dredging events. The calculated shoaling rates were then divided by the total dredging length to provide a shoaling rate per LF as follows: CY/Month/LF. The CY/Month/LF values were then used to evaluate the potential shoaling rates for the Turning Basin Expansion. The estimated maintenance dredging rate for the Anchorage Basin and the Sound Channel from 1995 to 2009 is the slope of the trend line, 2.6 MCY per year, shown in Figure 4-1.

---

<sup>1</sup> The presentation by Welp (2011) provides a figure showing the difference in channel bottom elevation based on survey method. The total yardage for the test cross section was calculated, and the difference between the results of the 200 KHz and 41 KHz surveys is 286,150 CY.

A summary of the calculated shoaling rates, including hurricane events, is provided in Table 4-4. In addition to the short- and long-term shoaling analyses described above, a short-term analysis (Table 4-5) was performed using the dredging quantity data provided by Weeks for the most recent dredging event for the Anchorage Basin and upper Sound Channel. The calculated shoaling rates are consistent with those displayed in the final years of the long-term analyses.

As shown in Table 4-4, the average shoaling rate since the completion of the 1992 deepening is 4 CY/Month/LF for the Anchorage Basin and 6 CY/Month/LF for the upper Sound Channel. Using the average shoaling rates, the average annual shoaling in the proposed 4,400 LF Turning Basin and berthing areas will vary from 211,000 to 317,000 CY per year. The estimated total shoaling over the 30-year life of the Turning Basin project ranges from 6.3 to 9.5 MCY. The shoaling will likely redistribute within the larger basin footprint based on the hydrodynamic forces within the revised system, including vessel traffic and wind and wave climates. The current shoaling pattern is from south to north, with the majority of the shoaling occurring in the southern third of the Anchorage Basin between dredging cycles. The soft channel muds and longshore sediments will deposit in the lessor tidal current area provided by the proposed turning basin.

**Table 4-2**  
**Gulfport Sound Channel Dredging Summary and Shoaling Rates<sup>1</sup>**

Dredge			Stations <sup>3,4,5</sup>			Volume <sup>6,7</sup> (CY)	Shoaling	
Start	Complete	Months Between Dredging Events <sup>2</sup>	Start	End	Length (LF)		CY/MON	CY/MON/LF
6/12/1995	7/6/1995	--	08+90	275+00	26,610	2,469,212	--	--
9/18/1996	10/25/1996	15	08+90	470+30	46,140	8,973,952	598,263	13
11/2/1998	1/31/1999	25	08+90	430+50	42,160	4,883,333	195,333	4.6
1/14/2000	3/4/2000	12	08+90	444+95	43,605	2,799,500	233,292	5.4
7/14/2001	10/4/2001	17	08+90	00+00	40,551	3,030,326	178,254	4.4
1/11/2003	4/22/2003	16	08+90	440+00	43,110	<b>4,151,013</b>	259,438	6
7/29/2004	11/22/2004	16	08+90	424+40	41,550	<b>2,678,141</b>	167,384	4
11/17/2006	2/28/2006	24	08+90	305+51	29,661	<b>2,142,683</b>	89,278	3
9/26/2007	11/24/2007	19	12+65	530+00	51,735	5,105,006	268,685	5.2
3/15/2009	8/15/2009	16	52+25	610+50	55,825	5,171,419	323,214	5.8

## Notes:

- Information provided in this table is compiled from the USACE dredging history cards.
- Calculated using complete date from previous dredge event and start date from next dredge event. Values are rounded up to the nearest month.
- Post-deepening (1992) Anchorage Basin stationing -40+33.43 (north Anchorage Basin) to 8+90 (entrance at south Anchorage Basin).
- Stationing for the harbor and channel areas was adjusted prior to dredging in 2009.
- Revised harbor stationing 0+00 (north Anchorage Basin) to 50+75 (entrance at south Anchorage Basin).
- Bolded dredging quantities are estimated from the total maintenance dredging quantity.
- Increased quantity for 1996 dredging is assumed to be a result of Hurricane Opal.

**Table 4-3**  
**Gulfport Anchorage Basin Dredging Summary and Shoaling Rates<sup>1</sup>**

Dredge			Stations <sup>3,4,5,6</sup>			Volume <sup>7,8</sup> (CY)	Shoaling	
Start	Complete	Months Between Dredging Events <sup>2</sup>	Start	End	Length (LF)		CY/MON	CY/MON/LF
9/18/1996	10/25/1996	--	08+90	-13+93	2,283	99,092	--	--
1/14/2000	3/4/2000	39	08+90	-40+40	4,930	110,300	2,828	0.6
2/1/2003	2/28/2003	35	08+90	-21+21	3,011	<b>98,400</b>	2,811	0.9
7/29/2004	11/22/2004	17	-01+30	-30+20	2,890	<b>60,900</b>	3,582	1.2
11/17/2005	2/28/2006	12	08+90	00+00	890	<b>14,800</b>	1,233	1.4
4/7/2009	5/16/2009	38	00+00	50+75	5,075	2,145,713	56,466	11.1

## Notes:

- Information provided in this table is compiled from the USACE dredging history cards.
- Calculated using complete date from previous dredge event and start date from next dredge event. Values are rounded up to the nearest month.
- Post-deepening (1992) Anchorage Basin stationing -40+33.43 (north Anchorage Basin) to 8+90 (entrance at south Anchorage Basin).
- Stationing for the harbor and channel areas was adjusted prior to dredging in 2009.
- Revised harbor stationing 0+00 (north Anchorage Basin) to 50+75 (entrance at south Anchorage Basin).
- Dredging history card value for 1996 maintenance dredging adjusted to indicate -13+93 end station for Anchorage Basin dredging.
- Bolded dredging quantities are estimated from the total maintenance dredging quantity.
- Increased quantity for 2009 dredging is assumed to be a result of Hurricane Katrina.

**Table 4-4**  
**Gulfport Upper Sound Channel and Anchorage Basin Dredging and Shoaling Rate Summary<sup>1</sup>**

Value	Unit	Upper Sound Channel			Anchorage Basin		
		Average	Maximum	Minimum	Average	Maximum	Minimum
Months	MONTH	18	25	12	29	39	12
Station Length	LF	43,816	55,825	29,661	3,360	5,075	890
Dredge Volume	CY	4,326,153	8,973,952	2,142,683	486,023	2,145,713	14,800
Shoaling Rate	CY/MONTH	257,016	598,263	89,278	13,384	56,466	1,233
	CY/MONTH/LF	6	13	3	4	11.1	0.6

Note:

1. Extreme events are included in this analysis to provide an appropriate range to the maximum and average values.

**Table 4-5**  
**Gulfport Upper Sound Channel and Anchorage Basin Short-Term Shoaling Rates<sup>1</sup>**

Location	Stations		Length (LF)	Volume (CY)		From Dredge Date	To Dredge Date	Shoaling Rate (CY/MON/LF)
	Start	End		Design Depth <sup>2</sup>	Overdepth <sup>3</sup>			
Lower Anchorage Basin	24+00	50+75	2,675	393,740	208,490	5/16/2009	3/1/2011	10.5
Upper Sound Channel	50+75	72+00	2,125	82,010	45,220	8/15/2009	3/1/2011	3.2

Notes:

1. Survey data and quantities for short-term shoaling calculations were provided by Weeks.
2. Design depth is -36 feet MLLW plus 2 feet advanced maintenance (total design depth of -38 feet MLLW).
3. Overdepth is 2 feet.

#### 4.4 Proposed Eastern Breakwater

The Project design includes the addition of a breakwater along the eastern border of the FNC with an opening to allow shallow draft navigation access to the Bert Jones Yacht Basin. Because the proposed breakwater may influence shoaling rates, the DMMP includes an analysis of the breakwater design. Michael Baker Jr., Inc., (Baker) analyzed the impacts of the proposed breakwater and evaluated four alternatives. The Baker *East Breakwater Configuration Alternatives* analysis included three alternatives with breakwaters along the eastern border and one alternative aligned with the southern boundary of the proposed Turning Basin Expansion (Baker 2011). The breakwater configuration shown in Figure 1-2 was not analyzed by Baker. The Baker (2011) alternatives are summarized as follows:

- **Alternative 1:** Two collinear breakwaters offset 350 feet from the Sound Channel and Anchorage Basin; a 580-foot-wide gap in the breakwater to accommodate the Small Craft Channel exiting the Bert Jones Yacht Basin on the eastern side of the Port
- **Alternative 2:** Two parallel, staggered breakwaters offset 400 feet and 650 feet from the Sound Channel and Anchorage Basin; a 250-foot-wide gap in the breakwater to accommodate the Small Craft Channel exiting the Bert Jones Yacht Basin on the eastern side of the Port
- **Alternative 3:** One breakwater south of the proposed Turning Basin Expansion offset at approximately 450 feet; the eastern edge of the breakwater is 350 feet from the Sound Channel
- **Alternative 4:** One breakwater on the eastern side of the Small Craft Channel exiting the Bert Jones Yacht Basin; this alignment extends farther south than Alternatives 1 and 2 to provide protection to the proposed Turning Basin Expansion and West Pier Terminal Expansion

Baker's analysis (Baker 2011) presented a site conceptual model of the nearshore area along the proposed breakwater alignments. To analyze the alternatives, Baker used the USACE STeady-state spectral WAVE (STWAVE) model. The model design parameters included a typical Mississippi Sound yearly event with a wind speed of 18 meters per second (40 miles per hour) and south (180 degrees) and east (85 degrees) wind scenarios. Initial model runs were performed to assess the baseline scenario (i.e., without breakwater protection) for the two wind direction scenarios. The West Pier Terminal Expansion footprint and the Turning



Basin Expansion were both included as part of the baseline model grid. As noted by Baker in their analysis, the STWAVE model is limited in areas with abrupt changes in bathymetry, such as in the Anchorage Basin and FNC. Therefore, further analysis using a phase resolving wave model would be necessary to assess the effects in such areas.

As described in Baker's analysis (Baker 2011), Alternative 4's breakwater alignment provides the greatest easterly event protection to the proposed Turning Basin and West Pier Terminal Expansion. Alternative 3 is the only one providing significant protection to the Anchorage Basin for events originating from the south. Baker proposes that both be utilized for the future expansion of the Port, providing the most conservative protection scheme. The breakwater configuration shown in Figure 1-2 is a combination of Alternatives 3 and 4.

Although localized effects of eddies and turbulent zones at the edges of the proposed breakwater have not been evaluated, Baker assumed that accretion could increase for these areas (Baker 2011). Alternative 4 is offset 650 feet from the Sound Channel, and while localized accretion is expected, it is not anticipated to result in extreme variations for the current shoaling rates experienced in the channel.

Overall, Baker's analysis concludes that constructing a breakwater is not likely to positively or negatively affect the deposition of littoral sand material in the vicinity of the Anchorage Basin or, in general, increase the deposition of fine and cohesive sediment at the Port. Baker summarized that it is likely that the fine and cohesive sediments will be affected by the alterations in Port geometry and vessel traffic (Baker 2011). The DMMP analysis presumed that these existing sediments within the Anchorage Basin will be redistributed over a larger area once the Turning Basin Expansion construction has been completed.

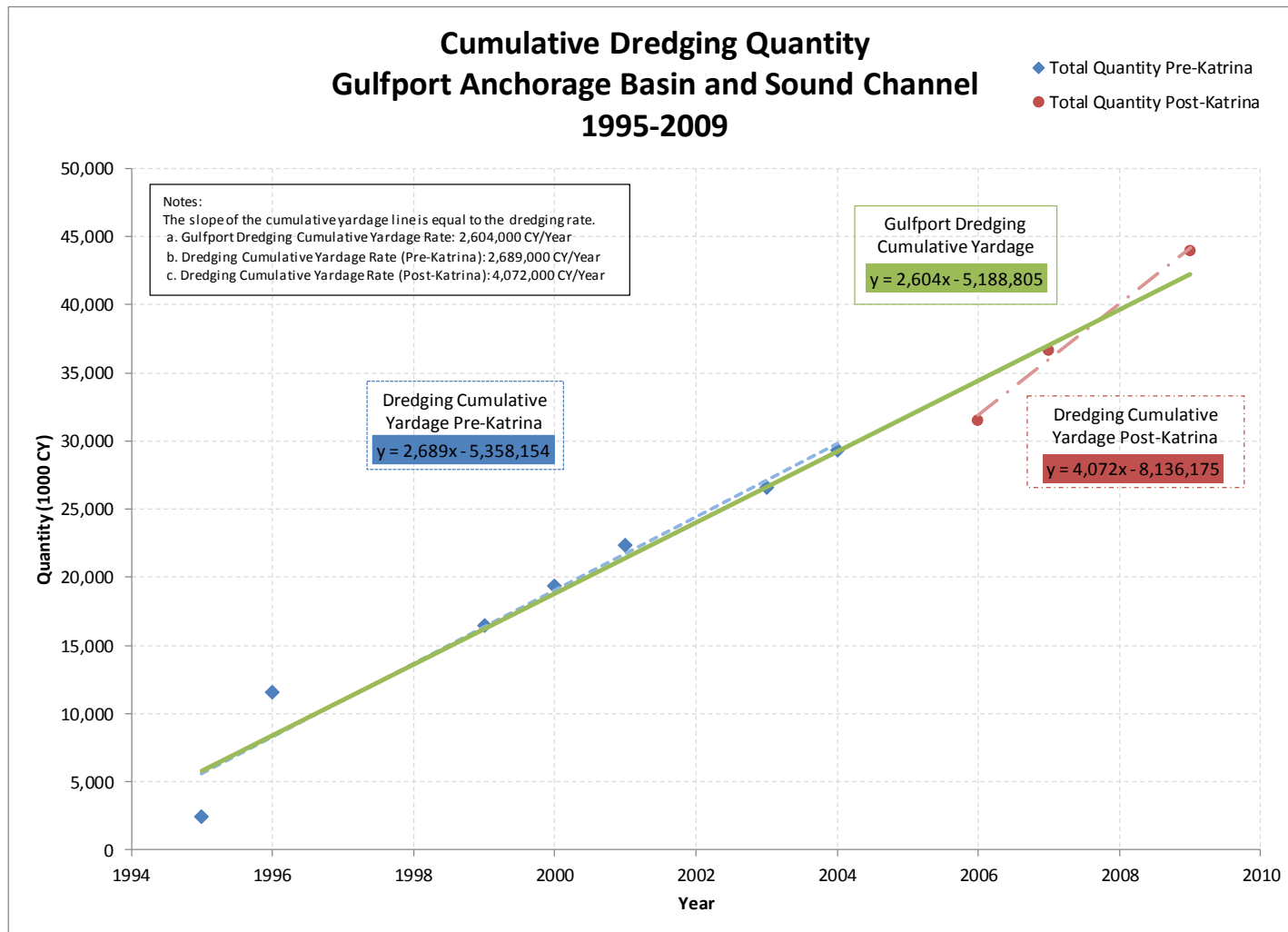

**Figure 4-1**  
**Cumulative Dredging Quantity Gulfport Anchorage Basin and Sound Channel**

---

## 5 SEDIMENT CHARACTERIZATION

Characterization of the sediment chemical profile is necessary prior to dredging and placement. This section discusses the available physical and chemical geotechnical data for the Project. This information will be used to determine if the proposed dredged material discussed in Section 6 meets the requirements for placement in BU sites and/or the ODMDS. The criteria that the dredged materials must meet for both placement options are discussed in Section 7.

### 5.1 General Sediment Geology in the Vicinity of the Project

The Port is located along the north shoreline of the Mississippi Sound (Figure 1-1). Research indicates that approximately 3,500 years ago, the Mississippi River passed on the eastern side of New Orleans and delivered sediment to the St. Bernard delta region as far east as the present-day Chandeleur Islands (Byrnes et al. 2011; Otvos and Giardino 2004). A visual representation of the sediment distribution from the USACE 1976 Final EIS (Upshaw et al. 1966) is shown in Figure 5-1. The nearshore sediments range from medium to coarse sands at the shoreline to a large area of silt and clay muds approximately 2 miles offshore.

The Otvos and Giardino (2004) geologic cross section (Figure 5-2) depicts the location and types of subsurface soils found along a transect extending south from the Gulfport Harbor area to Ship Island. The upper reach contains “Pleistocene marine and alluvial units,” while the lower reach is described with upper layers (0 to 30 feet mean sea level [MSL]<sup>2</sup>) of “very low salinity, mud, clay, sand mud” and a lower layer (30 feet to 65 feet MSL) of “Pleistocene marine and alluvial units” (Otvos and Giardino 2004).

### 5.2 Turning Basin and West Terminal Geotechnical Studies

This section provides historical and recent geotechnical data from sediments collected at the Port’s Anchorage Basin and the adjacent FNC. Figure 5-3 shows the location of some of the boring locations. Figure 5-4 shows the location of the dredging units and sampling locations from the *Sampling and Analysis Report Gulfport Turning Basin* (Anchor QEA 2013) study, which is summarized in Section 5.2.4.

---

<sup>2</sup> Depths below 0 feet MSL are positive values.

### 5.2.1 USACE Soil Classification Data

Seven borings from the historical boring logs and sediment test results from the USACE channel deepening (USACE 1992) and widening contract documents (USACE 2009a) were selected for evaluation based on their location to the proposed Turning Basin Expansion. The borings were classified using the Unified Soil Classification System (USCS), which describes the soil's grain size and texture. As shown in Table 5-1, the majority of the sample material is classified as OH, which is fine-grained medium to high plasticity organic silt and clay. Other materials that were identified include silty and clayey sands (SM and SC) and inorganic silts and clays (ML and CH).

**Table 5-1**  
**USACE Historical Boring Log Data Analysis**

Boring ID	Year	Coordinates		Total Length (feet)	Total Material Length (feet)				
		Easting	Northing		Material Type <sup>1</sup>				
					ML	SM	CH	OH	SC
SS-2	1956	905641	308986	10.8	--	--	--	7.8	3
SS-3	1956	906400	308106	15.1	--	--	3.1	12	--
SS-4	1956	906891	307266	16.5	--	--	--	15	1.5
SS-5	1956	907491	306476	15.2	--	--	--	15.2	--
SS-6	1956	908241	305406	13.7	--	--	--	13.7	--
GSC-1-62	1962	906721	307686	10.5	--	--	10.5	--	--
GP-3-87	1987	908771	305046	13.2	4.2	9	--	--	--
Total				95	4.2	9	13.6	63.7	4.5

Notes:

1. Material definitions from USACE Appendix A (1992, 2009a)

CH = inorganic clays of high plasticity, fat clays

ML = inorganic silts and very fine sands, rock flour, sandy silts, or clayey silts with slight plasticity

OH = organic clays of medium to high plasticity, organic silts

SC = clayey sands, sand-clay mixtures

SM = silty sands, sand-silt mixtures

The USACE (2011) dredging history cards classify the Anchorage Basin maintenance materials as soft to very soft silts and clays. For the 2011 FNC widening, the USACE performed acoustic density profiles along the channel to determine the soil type descriptions and density ranges of the materials adjacent to and along the channel bottom. The profiles along the Sound Channel bottom indicate the presence of fluid mud with estimated densities

in the range of 1.00 to 1.20 grams per cubic centimeter (62.4 to 74.9 pounds per cubic foot; USACE 2009a). These values are consistent with those reported in available literature (McAnally et al. 2007a).

Because the Anchorage Basin was not part of the FNC widening project, the profiles do not extend into this area. However, it is reasonable to assume that fluid mud is also present in the Basin because fluid mud can result from agitation caused by local vessel traffic, regional hydrodynamics, dredged materials placed into open water, vertical entrainment, ambient and storm tidal conditions, or gravity flows (McAnally et al. 2007a).

### 5.2.2 USACE Sediment Grain Size Analysis

Prior to the 2011 widening project of the Sound and Gulf channels, EA Engineering, Science and Technology (EA) performed sediment characterization on the FNC for the USACE in 2004 (Figure 5-3). The *Sediment Quality Characterization of the Gulfport Harbor Federal Navigation Channel* report reviewed four alternatives as follows: No Action (i.e., Continued Maintenance), Deepening, Widening, and Deepening/Widening (EA 2006). Table 5-2 provides a summary of the nine grain size analyses completed for the sediment characterization of the Anchorage Basin and northern portion of the Sound Channel. The sample IDs with “M” are for the No Action, or continued maintenance dredging alternative, “D” for Deepening, “W” for widening alternatives, and “DW” for Deepening/Widening.

**Table 5-2**  
**Sediment Characterization Grain Size Analyses (EA 2006)**

Sample ID	Gravel (%)	Sand (%)	Silt (%)	Clay (%)
GH04-01-M-SED	0	23.3	23.1	53.6
GH04-01-D-SED	0.6	77	8.3	14.1
GH04-01-D-SEDREP	0	68.6	12.9	18.5
GH04-02-M-SED	0	10.2	20.9	68.9
GH04-02-D-SED	1.0	45.5	14.6	38.9
GH04-01/02-M-SED	0	16.8	18.8	64.4
GH04-01/02-D-SED	0	64.1	10.6	25.3
GH04-03-W-SED	0.1	73.9	4.3	21.8
GH04-03-DW-SED	2.4	43.5	17.5	36.5

### 5.2.3 Proposed Berth 7 Turning Basin West Pier Expansion Sediment Borings

Thompson Engineering (Thompson) and URS Corporation (URS) collected sediment samples to evaluate if the dredged material from the Berth 7 Turning Basin Expansion Project met the requirements for ocean disposal; borings were collected and analyzed from nine locations (Figure 5-3) adjacent to the West Pier (Thompson/URS 2003). Table 5-3 provides the USCS grain size and the textural classifications from the analysis and shows all of the sediments were classified as inorganic low-plasticity silts.

**Table 5-3**  
**Sediment Characterization Grain Size Analyses (Thompson/URS 2003)**

Boring ID	Textural Classification	Percent		
		Sand	Silt	Clay
09GP02-01	Gray Sandy Silt	32	24.1	43.9
GP02-02	Gray Sandy Silt	46.8	17.8	35.4
GP02-03	Gray Silt with Sand	28.9	27.3	43.8
GP02-03 (DUP)	Gray Silt with Sand	27.8	27.1	45.1
GP02-04	Gray Silt with Sand	20	26.9	53.1
GP02-05	Gray Sandy Silt	45.4	19.5	35.1
GP02-06	Gray Silt with Sand	22.7	25.4	51.9
GP02-07	Gray Silt with Sand	16.4	27.9	55.7
GP02-07 (DUP)	Gray Silt	10.3	27.3	62.4
GP02-08	Gray Sandy Silt	35.7	21	43.3
GP02-09	Gray Silt	15	28.5	56.5

### 5.2.4 Turning Basin Expansion Sediment Study

Anchor QEA collected samples in November and December 2012 for the *Sampling and Analysis Report Gulfport Turning Basin* (Anchor QEA 2013). As shown in Figure 5-4, the sampling area was comprised of ten dredge units (DUs; Anchor QEA 2013). Three cores were collected from each DU to a depth of -40 feet MLLW and composited together to form a sample, for ten sediment samples (Anchor QEA 2013). Table 5-4 summarizes the grain size from the analysis of the composite samples and shows that samples were largely comprised of clay.

**Table 5-4**  
**Sediment Characterization Grain Size Analyses (Anchor QEA 2013)**

Composite Sample ID	Percent		
	Sand	Silt	Clay
GP-DU1	36.4	17.6	46
GP-DU2	42.3	21.7	36
GP-DU3	46.1	18.1	35.8
GP-DU4	6.2	24.4	69.4
GP-DU5	2.8	25.2	72
GP-DU6	17.3	26.7	56
GP-DU7	10.6	21.9	67.5
GP-DU8	27.1	30.3	42.6
GP-DU9	10.6	28	61.4
GP-DU10	57.3	13.5	29.2

### 5.3 Bulk Sediment Chemistry

#### 5.3.1 2006 EA Study Report

The *Sediment Quality Characterization of the Gulfport Harbor Federal Navigation Channel* by EA (2006), described in Section 5.2.2, also included chemical analyses of bulk sediment, site water, standard elutriates, water column bioassays, and whole sediment bioassays.

Testing results for arsenic, nickel, and total polychlorinated biphenyls (PCB) are provided in Table 5-5. Threshold effect levels (TEL) exceedances are documented in several samples; however, none of the samples tested exhibited analyte concentrations over the established probable effects level (PEL). All other analytes tested were below their respective TEL guidelines (EA 2006).

**Table 5-5**  
**Sediment Arsenic, Nickel, and Total PCBs Concentrations<sup>1,2</sup>**

Sample ID	Arsenic	Nickel	Total PCBs
	TEL/PEL = 7.24/41.6 (mg/kg)	TEL/PEL = 15.9/42.8 (mg/kg)	TEL/PEL = 21.6/189 (µg/kg)
GB04-REF	6.4	4.9	6.8
GH04-01-M	8	14	15.3
GH04-01/02-M	9.7	15.8	4.7



Sample ID	Arsenic	Nickel	Total PCBs
	TEL/PEL = 7.24/41.6 (mg/kg)	TEL/PEL = 15.9/42.8 (mg/kg)	TEL/PEL = 21.6/189 (µg/kg)
GH04-02-M	<b>11.7</b>	<b>22.4</b>	10.1
GH04-03-W	5.6	8.9	1.7
GH04-01-D	1.7	4.9	3.9
GH04-01/02-W	3.2	3.6	2.2
GH04-02-D	6.2	5.6	<b>120.6</b>
GH04-03-DW	6.7	< 0.1	2

## Notes:

1. This table is populated with data from the EA (2006) sediment characterization report.
2. The sample results in bold exceed the TEL for the prescribed analyte.

### 5.3.2 2013 Anchor QEA Sampling Report

As detailed in the Anchor QEA *Sampling and Analysis Report Gulfport Turning Basin* (2013), metals were detected at all ten DUs and both references at concentrations below their respective effects range median (ERM) values. Only two polycyclic aromatic hydrocarbons (PAHs) were detected above ERM values at one station, and one PAH was detected above the ERM value at one reference (Anchor QEA 2013). Total petroleum hydrocarbons (TPHs), pesticides, organometallic compounds, and semi-volatile organic compounds (SVOCs) were either not detected at a level of concern or not detected at all in the samples from the Gulfport Turning Basin and reference locations (Anchor QEA 2013). Chemical analyses showed Gulfport sediments and reference sediments were similar and generally lacking in contaminants of concern (Anchor QEA 2013). Table 13 of the *Sampling and Analysis Report Gulfport Turning Basin* (Anchor QEA 2013) provides a summary of the sediment chemistry results.

## 5.4 Site Water and Standard Elutriate Testing

### 5.4.1 2006 EA Study Report

The EA study (2006) detected concentrations of ammonia, phosphorus, aluminum, arsenic, chromium, nickel, selenium, zinc, two PCB congeners, and one dioxin congener (octachlorodibenzo-p-dioxin) in site water samples from the Gulfport Harbor. Elutriate testing shows that concentrations of most target constituents were at the detection limit or at low levels similar to the water column concentration, which indicates that the sediments are

not leaching these constituents into the water column (EA 2006). Some samples had elevated concentrations of ammonia, cyanide, nickel, total PCBs, and several chlorinated pesticides (4',4'-DDT; 4',4'-DDD; dieldrin; endrin; EA 2006). The exceedances for each analyte are provided in Table 5-6.

**Table 5-6**  
**Standard Elutriate Exceedance Matrix<sup>1</sup>**

Analyte	Exceedance Criteria		Remarks
Ammonia <sup>2</sup>	Acute	3.10 mg/L	Exceed by factors ranging from 3.9 to 12 (acute) and 26 to 80 (chronic)
	Chronic	0.466 mg/L	
Cyanide	Acute	1 µg/L	Exceedance (8 µg/L) at one station: GH04-03-DW
	Chronic	1 µg/L	
Nickel	Chronic	8.2 µg/L	Minor exceedance (8.8 µg/L) at one station: GH04-03-W
Dieldrin	Chronic	0.0019 µg/L	Exceedances at stations GH04-01/02-M, GH04-03-W, GH04-03-DW by factors ranging from approximately 2 to 4
Endrin	Chronic	0.0023 µg/L	Exceedance by factors of approximately 4 and 1.4 for stations GH04-01/02-M and GH04-03-W, respectively
PCB <sup>3</sup>	None	30 ng/L	Concentration range (8.29 to 17 ng/L) comparable to the total PCB concentration in the site water (8.75 ng/L)

Notes:

- None of the chlorinated pesticides that exceeded USEPA screening values in elutriates were detected in sediment from these locations.
- EA (2006) calculated the USEPA acute (3.10 mg/L) and chronic (0.466 mg/L) criteria for determining the toxicity of ammonia to aquatic life based on measurements collected during the sampling event: salinity of 28 parts per thousand, a temperature of 28.9°C, and pH of 8.0 (measured at the mid-depth of the water column).
- PCB non-detect concentration is equal to half of the minimum detection limit.

#### 5.4.2 2013 Anchor QEA Sampling Report

The site water and elutriate testing is summarized in Table 12 of the *Sampling and Analysis Report Gulfport Turning Basin* (Anchor QEA 2013). The Anchor QEA (2013) report noted the following for the site water:

- All analytes were below USEPA and Mississippi State water quality criteria.
- Ammonia, cyanide, and pesticides were not detected in the samples.
- Only total arsenic and total selenium were detected at concentrations greater than the method reporting limit (MRL).
- Dissolved arsenic and selenium were also detected in the site water.

- Total chromium (III and IV), dissolved lead, and pentachlorophenol were estimated at concentrations below the MRL. All other total and dissolved metals were not detected.

The Anchor QEA (2013) report noted the following for the elutriate testing:

- Ammonia and several total and dissolved metals, including arsenic, chromium (total), copper, lead, nickel, selenium, and zinc were detected above the MRL in one or more elutriate samples.
- Cadmium, chromium VI, mercury, and silver were not detected above the MRL in any elutriate sample.
- In all samples, cyanide, organometallic compounds, semivolatile organics, and pesticides were not detected in any of the elutriate samples. Dissolved copper in the GP-DU5-Comp elutriate sample exceeded the USEPA and Mississippi State water quality criteria by 2.3 times.

## 5.5 Bioassay Testing

The purpose of bioassay testing (water column and whole sediment) is to evaluate the survival rates of test organisms exposed to the sediment elutriates and whole sediment. The criterion that is used for this evaluation is the limiting permissible concentration (LPC) for each of the given analytes. LPCs are intended to establish a value for specific marine organisms at which no sub-lethal adverse effects are observed or substantial acute or chronic toxicity is detected; the evaluation considers median effective (sub-lethal) concentration (EC<sub>50</sub>) or median lethal concentration (LC<sub>50</sub>) (USEPA/USACE 1991; 2008). For water column testing, the USEPA/USACE (1991) establishes that the LPC for ODMDS placement is equivalent to 0.01 of the EC<sub>50</sub>/LC<sub>50</sub> within a 4-hour dilution period after placement. In the case of whole sediment bioassay testing, if the tested sediments cause a mortality rate that is statistically greater than reference sediments and exceed the reference sediment mortality by at least 10 percent (amphipod tests are allowed 20 percent mortality), then the LPC of the tested sediments has not been fulfilled.

EA (2006) assessed the biological effects of sediment elutriate toxicity in three water column organisms (*A. punctulata* [ammonia-stripped], *A. bahia*, and *C. variegates*) as part of the

sediment characterization. The lowest EC<sub>50</sub>/LC<sub>50</sub> value reported (GH04-03-DW) would require a dilution of approximately 111 fold to achieve the LPC. EA (2006) anticipated that dilution modeling (Short-Term FATE [STFATE]) would be performed to predict the on-site conditions at the disposal site after the material has been placed. Whole sediment testing results indicated survival rates of organisms (*N. arenaceodentata* [ammonia purged] and *L. plumulosus*) that were significantly lower than the reference, but not greater than 20 percent lower; therefore, the results of these bioassay tests indicated that the sediments meet the LPC requirements.

Anchor QEA bioassay testing consisted of solid phase (SP) tests with two species and suspended particulate phase (SPP) tests with three species. Sediment from Gulfport Turning Basin DUs and reference sites consisted of low total organic carbon (TOC) concentrations. Survival in the SP polychaete test was high. Survival in the initial SP amphipod test was consistently low in all sediments from the Gulfport Turning Basin, and it was hypothesized that the low TOC concentrations of the material confounded the test results. After approval from the USEPA, a modified SP amphipod test (inclusion of a feeding regime) was conducted that resulted in high survival of amphipods in all re-tested sediments.

Survival in the mysid shrimp SPP test met the LPC requirements for ocean disposal. The echinoderm SPP test showed statistically significant reduced normal development in elutriate concentrations from four DUs, and the juvenile fish SPP test showed reduced survival in two DUs. Per Southeast Regional Implementation Manual (SERIM) guidance (USEPA/USACE 2008), STFATE modeling was conducted using sediment characteristics from the DU that exhibited the greatest effect relative to controls to determine ocean disposal suitability. Results of STFATE modeling indicated sediment from those DUs would be suitable for ocean disposal at the Gulfport Western and/or Pascagoula ODMDS.

Results of the SP and SPP bioassays and corresponding STFATE modeling indicated that sediments from the Gulfport Turning Basin were not acutely toxic to aquatic life and met the LPC requirements for ocean disposal.

## 5.6 Bioaccumulation

Bioaccumulation tests are designed to evaluate the potential of specific marine organisms (in this case, *Nereis virens* [sand worm] and *Macoma nasuta* [blunt-nose clam]) to be affected by chemicals found in sediments. For the EA 2006 study, neither test organism exhibited mortality that was significantly different than the reference sediment. Sand worms exposed to the site sediments were found to have tissue concentrations for five metals (manganese, mercury, selenium, silver, and zinc) that were statistically different from the reference sediment tissues. Blunt-nose clams exposed to site sediments were found to have tissue concentrations significantly different than the reference sediment for five metals (aluminum, cadmium, iron, lead, and manganese). Neither organism was found to have dioxin/furan or PCB tissue concentrations significantly different from the reference sediments. The uptake ratios calculated by EA (2006) for each of the metals listed were all slightly greater than one; however, aluminum, iron, manganese, and zinc were cited as metals that do not have a tendency to biomagnify, and selenium was classified as non-bioavailable.

For the Anchor QEA 2013 study, bioaccumulation testing on the sand worm and blunt-nose clam showed the Turning Basin sediment contaminants of concern were not present in concentrations statistically greater than U.S. Food and Drug Administration's (USFDA) action levels. Tissue samples from the sand worms and clams showed that all metals, except cadmium, were present in at least one sample from the Turning Basin samples. Except for one sample, DU-6 clam sample, the samples were free of PAHs. The DU-6 replicate sample for the clams had naphthalene concentrations of 17 micrograms per kilogram ( $\mu\text{g}/\text{kg}$ ). For PCBs, four replicates of DU-7 in the sand worm testing had total PCB concentrations ranging from an estimated 51.25 to 83.98  $\mu\text{g}/\text{kg}$ . One DU-7 replicate sample in the clam test had 13  $\mu\text{g}/\text{kg}$  of PCB. PCB was not detected in the remaining samples.

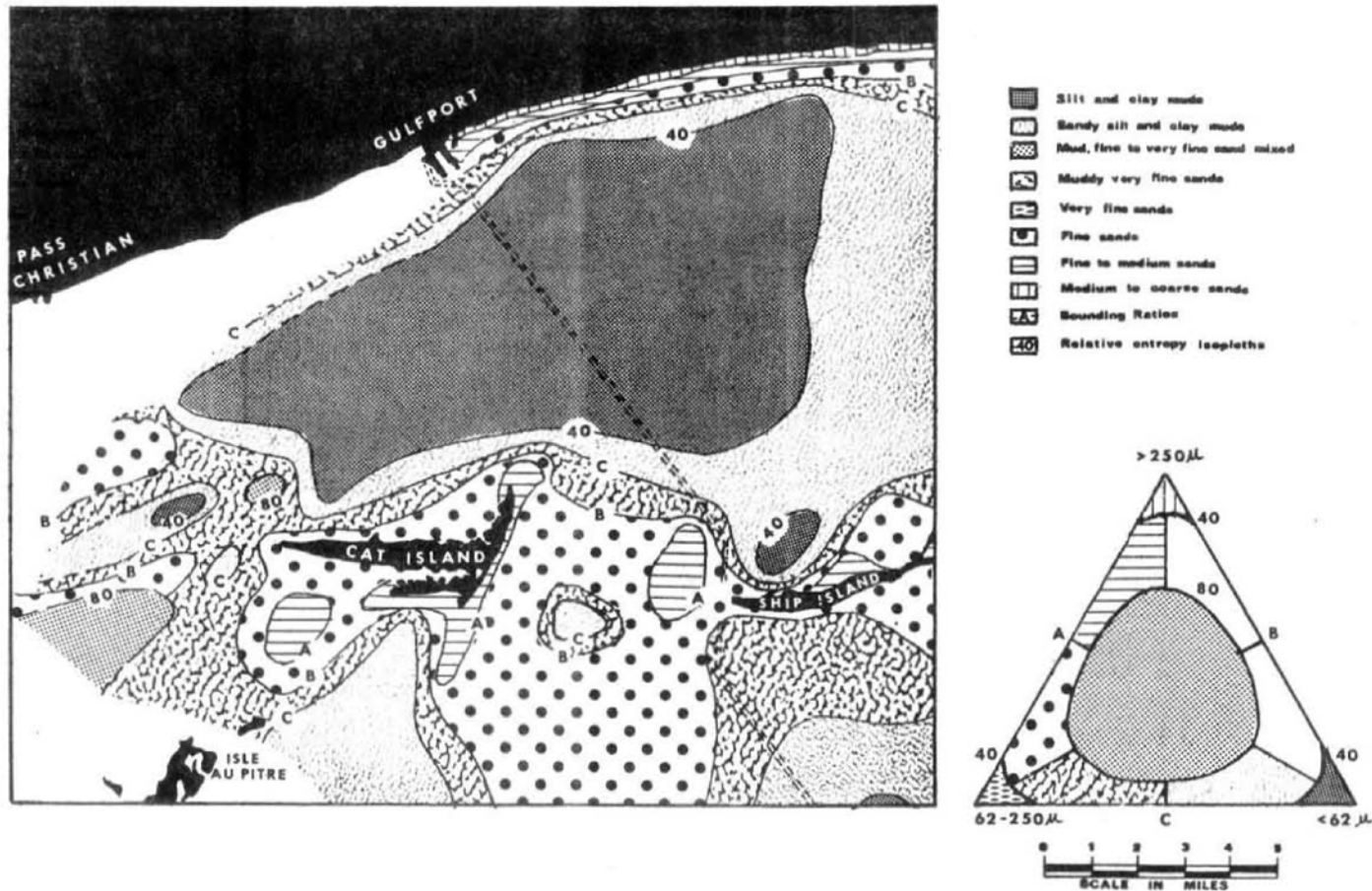

**Figure 5-1**  
**Distribution of Sediments in the Gulfport Ship Channel Area, Mississippi**

Source:

Upshaw, C.F., W.B. Creath, and F.L. Brooks, 1966. *Sediments and Microfauna off the Coasts of Mississippi and Adjacent States*. Mississippi State Geological Survey Bull. 106. 127pp.

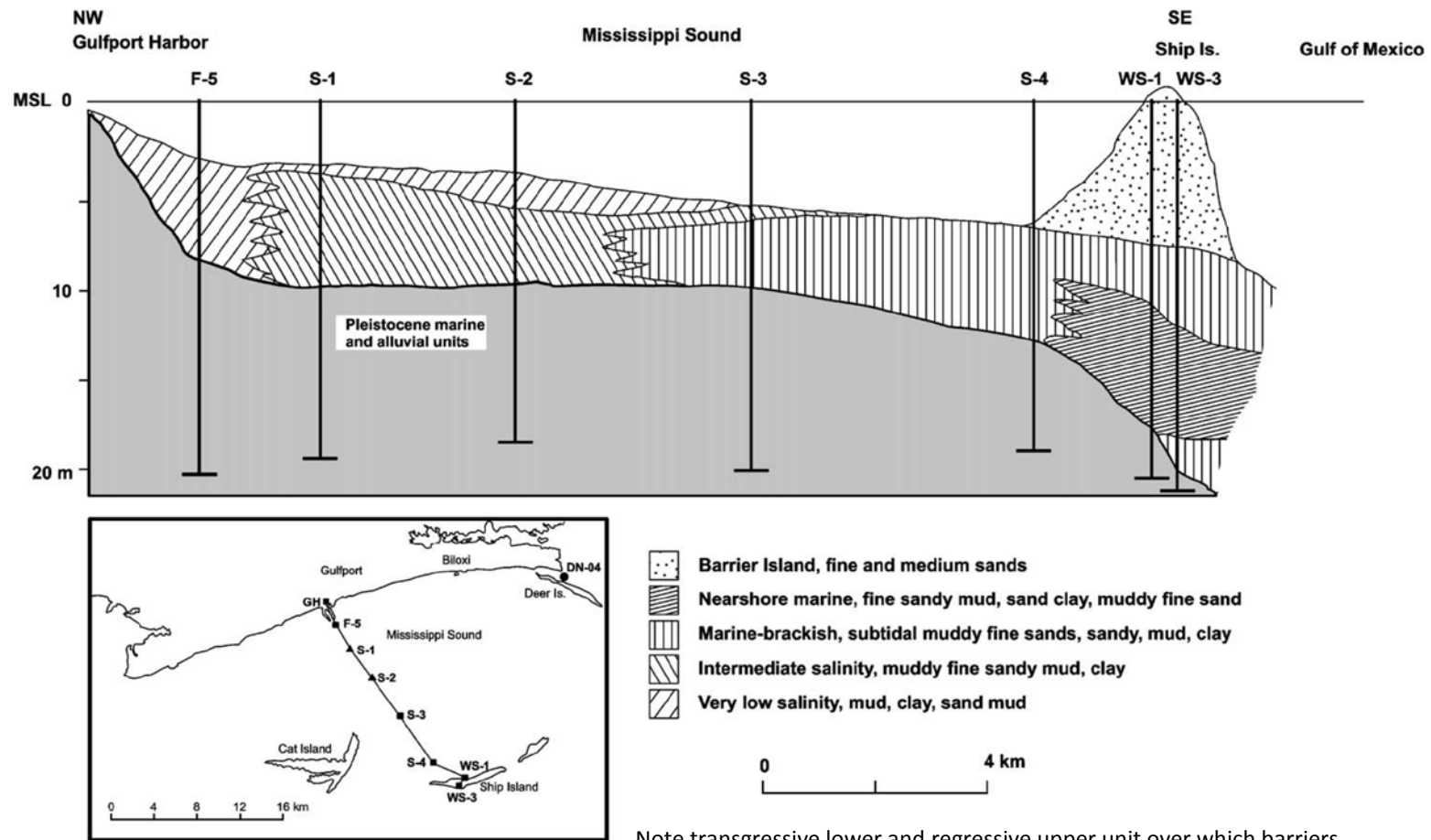

Note transgressive lower and regressive upper unit over which barriers emerged.

**Figure 5-2**  
**Gulfport Geologic Cross-Section**

Source:

Otvos, E.G., M.J. Giardino, 2004. Interlinked barrier chain and delta lobe development, northern Gulf of Mexico. *Sedimentary Geology* 169:47–73.



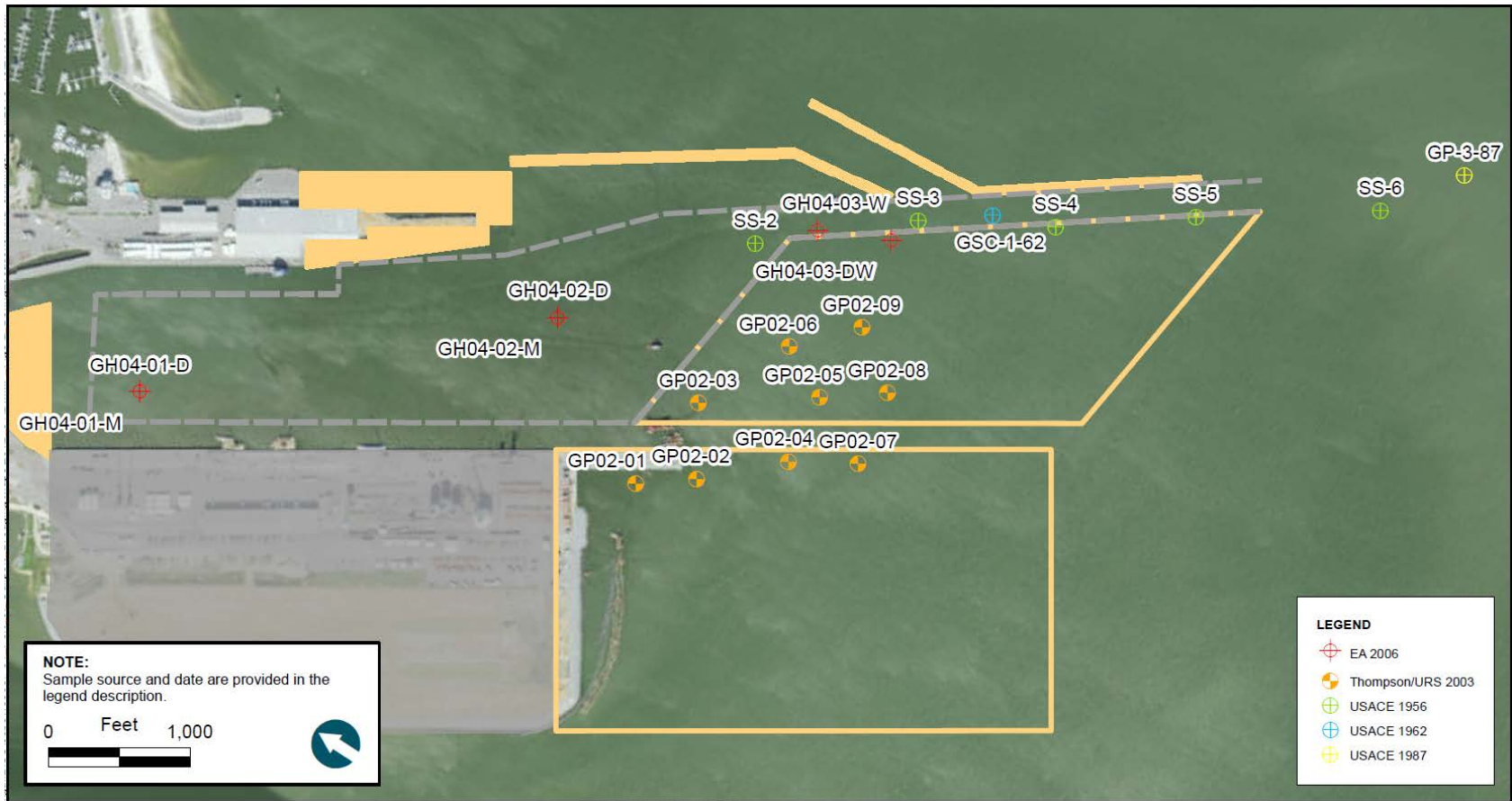

**Figure 5-3**  
**Sediment Boring Locations**

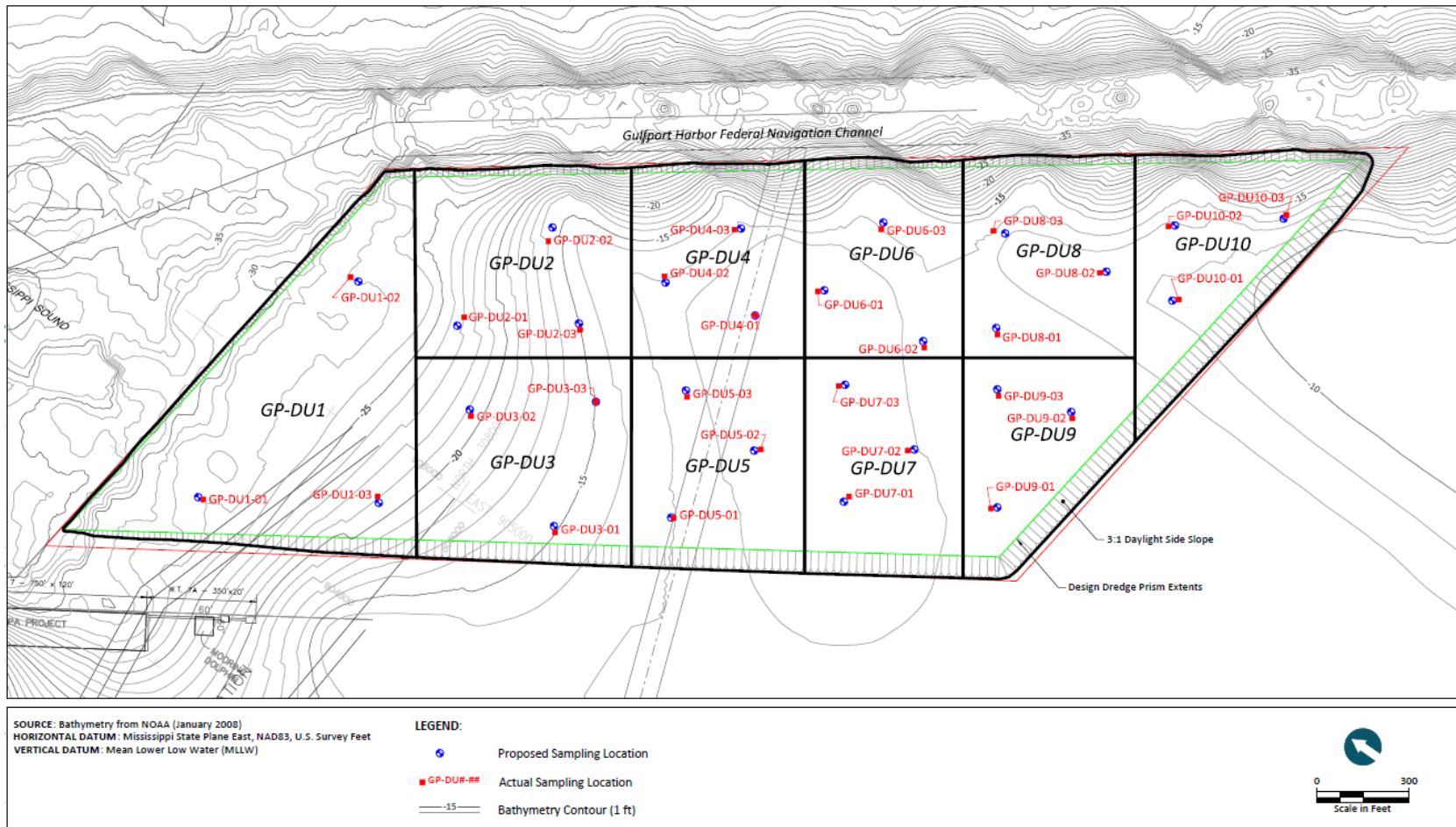

**Figure 5-4**  
**Turning Basin Dredging Units and Sampling Locations**

---

## 6 PROPOSED DREDGING ACTIVITIES

This section discusses the proposed dredging activities and volumes for the Project. The dredging activities include the West and East Pier Expansion, the Turning Basin construction, and the maintenance of the Turning Basin and additional berths.

### 6.1 West and East Pier Terminal Expansion

The Project proposes to expand the existing West Pier Terminal southward by 155 acres and 14.5 acres for the East Pier Terminal. The geotechnical engineering data collection has not yet occurred for the Terminal Expansion Project. For the DMMP, the dredging analysis will use the collective geotechnical data described in Section 5.

For the West Pier, boring logs in the vicinity of the proposed expansion (GP02-01, GP02-02, GP02-04, and GP02-07; Figure 5-3) indicate that the majority of the materials above -30 feet MLLW are soft to very soft clays with very little sands (Table 5-3). Soft clays are not suitable foundation soils for construction and would need to be dredged prior to constructing the terminal. The removal of the soft clays would also prevent mud waves into the adjacent estuary. Because there are no geotechnical borings in the area of the East Pier Terminal Expansion, the DMMP assumed the sediments in the area are similar to the borings near the West Pier expansion and dredging may be necessary to remove soft foundation materials.

To estimate dredging quantities for the West and East Pier Terminal Expansion, the calculations assumed a -20 feet MLLW dredging depth, which is consistent with the 24-acre expansion dredge design for the existing West Pier Terminal facility (Anchor QEA 2011). For the West Pier, the average sediment elevation (-11.2 feet MLLW) from the four core borings described above was used as the baseline bathymetry. Assuming the West Pier Expansion project will require removal of all the material from -11.2 feet to -20 feet MLLW, the total dredging volume for the 155-acre expansion area is approximately 2.4 MCY. To estimate dredging quantities for the East Pier Terminal Expansion, the National Oceanic and Atmospheric Administration (NOAA) Digital Elevation Model [DEM] (2008) of the Mississippi Gulf Coast was used as the baseline bathymetry. The estimated dredging quantity for the East Pier Terminal Expansion footprint is 560,000 CY, which includes 2 feet of overdepth tolerance.

## **6.2 Turning Basin**

As discussed in Section 1, the Turning Basin Expansion design includes dredging an 85-acre area adjacent to the Anchorage Basin and upper Sound Channel (Figure 1-2). The Project existing design depth is -36 feet MLLW, with 2 feet of advanced maintenance and 2 feet of allowable overdepth. The DMMP also addresses the dredging associated with the 30-year maintenance of the proposed turning basin.

### **6.2.1 Turning Basin Expansion**

A review of the 2011 USACE surveys shows that the average sediment elevation in the area is -12 feet MLLW. To construct the Turning Basin, approximately 3.7 MCY of sediment will be removed to reach the final -40 feet MLLW depth (-36 feet MLLW design depth plus 2 feet advance maintenance and 2 feet of overdepth). Dredging will also occur at the berthing facilities adjacent to the proposed West and East Pier Terminal Expansions and North Harbor Fill area. The dredging depth for the berths is -36 feet MLLW, which includes -32 feet MLLW design depth plus 2 feet advanced maintenance and 2 feet overdepth. The amount of material removed from the berthing areas is approximately 845,000 CY. Therefore, the total estimated dredging volume for constructing the Turning Basin is 4.55 MCY.

### **6.2.2 Turning Basin and Berth Maintenance Dredging**

The volume and frequency of maintenance dredging for the proposed Turning Basin Expansion and the berthing areas (West Pier Terminal Expansion, North Harbor Fill, and the Existing and proposed East Pier Terminals) were calculated using the Anchorage Basin and upper Sound Channel shoaling rates from Section 4.0. For the calculations, it was assumed that deposition occurs uniformly across the area over time—a reasonable assumption given the fluid mud material indicated by the USACE (2009a).

For the DMMP, the maintenance calculations assumed that dredging would occur once the sediment elevations reach 2 feet above design depths in the Turning Basin and berth areas. Therefore, to reach the expansion design elevations, approximately 825,000 CY of material would have to be removed from the Turning Basin, 155,000 CY from the West Pier berth, 65,000 CY from the North Harbor berth, and 210,000 CY from the East Pier berths for each maintenance event.

For the dredging frequency calculation, it was assumed that the proposed Turning Basin Expansion will experience shoaling similar to the upper Sound Channel as described in Table 4-4 (6 CY/Month/LF average and 13 CY/Month/LF maximum). The berthing areas will experience shoaling similar to the existing Anchorage Basin (4 CY/Month/LF average and 11 CY/Month/LF maximum). The maximum shoaling is included to account for seasonal, subtropical, and tropical storm events.

The resulting estimate indicates that maintenance dredging would be required approximately every 18 to 47 months for the Turning Basin Expansion and every 7 to 14 months for the berthing areas. These results can be compared to the historical data provided by the USACE, which indicate that the average duration between maintenance dredging events has been 18 to 29 months for the Northern Sound Channel and the Southern Anchorage Basin, but at a lower volume. Maintenance dredging is also dependent on funding, which could not be analyzed as part of this study or included in the decision matrix. In conclusion, the maintenance dredging volumes vary from 211,000 to 586,000 CY/year for the Turning Basin, 173,000 to 475,000 CY/year for the West Pier berths, 39,000 to 106,000 CY/year for the North Harbor berth and 63,000 to 172,000 CY/year for the East Pier berths.

---

## 7 DREDGED MATERIAL PLACEMENT SCREENING REQUIREMENTS

Placement options for the dredged material described in Section 6 include BU areas and ODMDS. In order for dredged material to be placed in BU and ODMDS locations, it must meet certain screening requirements. To determine if BU or ODMDS were viable placement options, a review of the screening requirements was performed for the DMMP. The screening requirements were then used along with the sediment data in Section 5 to determine if the dredged material from the dredging described in Section 6 could be placed in the selected BU and ODMDS locations.

### 7.1 Beneficial Use Sediment Screening Criteria

The *Final Master Plan for the Beneficial Use of Dredged Material for Coastal Mississippi* (Plan) (CH2M HILL 2011a) provides details for the interim guidance regarding the testing protocols for potential BU material. The purpose of these protocols is to encourage the use of dredged materials at BU sites rather than at upland placement locations. As stated in the Plan (CH2M HILL 2011a), the Mississippi Department of Marine Resources (MDMR) aims to do the following:

- *Provide regulators and permit applicants with consistent guidance for evaluating, sampling, and testing sediments to be dredged from waters of the state for potential use in Mississippi's Beneficial Use of Dredge Material Program.*
- *Minimize the burden on applicants and contractors as they seek compliance with Mississippi's Beneficial Use of Dredge Material Law (section 49-27-61, Mississippi Code of 1972) effective July 1, 2010.*
- *Establish non-analytical evaluation as the baseline for non-commercial/industrial (low risk) dredging projects.*
- *Delineate when bioassay screening is allowed and when chemical analysis will be required.*
- *Develop standardized chemical testing/screening methods for projects with higher risk due to association with certain commercial or industrial environments (At this time, the NOAA Screening Quick Reference Tables will be required unless more specific potential contaminant information is available and/or more focused or alternate testing methodologies are proposed by the applicant and accepted by the appropriate regulatory agencies.)*

These goals are supplemented with specific interim protocols, described in Table 7-1, for the evaluation, sampling, and analysis of materials from a proposed dredging project site.

**Table 7-1  
Interim Protocols for Dredge Material Analysis for Beneficial Use<sup>1</sup>**

<p>Evaluation<sup>2</sup></p>	<p>Any information provided by the applicant or their authorized agent regarding the potential for (or the absence of) chemical contamination at the project site or in the immediate vicinity or watershed could be considered to help reduce the need for additional analytical assessment. This could include:</p> <ul style="list-style-type: none"> <li>• Historical information regarding the use of the project site and/or adjacent orupstream sites.</li> <li>• Commercially available environmental record searches.</li> </ul>
<p>Sampling</p>	<p>Unless an alternative strategy is approved, the minimum sample collection interval will be:</p> <ul style="list-style-type: none"> <li>• For dredging projects totaling between 2,500 yd<sup>3</sup> and 25,000 yd<sup>3</sup>, a minimum of two grab samples (one pair) will be taken.</li> <li>• For typical channel dredging or similar “linear” projects, two samples will be from the centerline of the channel, one at the upstream limit and the other at the downstream limit.</li> </ul> <p>For projects exceeding the base volume of 25,000 yd<sup>3</sup>, an additional pair of grab samples will be taken on the centerline for each additional 25,000 yd<sup>3</sup> or part thereof. Each pair of samples will be composited so that each 25,000 yd<sup>3</sup> segment will be individually analyzed.</p> <p>Sample locations for nonlinear projects will be determined on a case by case basis. This sampling methodology may also be adjusted as appropriate on projects greater than 100,000 yd<sup>3</sup>. All sample locations will be preapproved by MDMR. The specific type of analysis to be run will dictate the sample size, retrieval and handling methods. Please contact the lab that will be used for specific instructions.</p>
<p>Analysis<sup>3</sup></p>	<p>Sediment Toxicity Tests:</p> <ol style="list-style-type: none"> <li>1. Method for assessing the Toxicity of Sediment-associated Contaminants with Estuarine and Marine Amphipods, Test Method 100.4. EPA/600/R-04/025, June 1994</li> <li>2. 10-day <i>Leptocheirus plumulosus</i> sediment toxicity test</li> </ol> <p>Includes initial weight data for representative test organisms and final weight data for each replicate of each treatment.</p> <p>Analytical Analyses:</p> <ul style="list-style-type: none"> <li>• Percent organic matter, total organic carbon, and total volatile solids</li> <li>• Particle size distribution</li> </ul> <p>Sample and shipping containers (ice chests): 1-gallon bucket with lid (HCl and DI Rinsed)</p>

Notes:

1. Reproduced from the final Master Plan for the Beneficial Use of Dredged Material for Coastal Mississippi (CH2M HILL 2011a).

2. Applicants or authorized agents may want to approach an initial evaluation of this type as they would a typical Phase 1 Environmental Assessment albeit with a focus on submerged/ aquatic aspects. Where no specific



information regarding the potential for contamination (or lack thereof) is provided by the applicant or authorized representative, or if public commentary or other information suggests a possibility of contamination for a noncommercial/nonindustrial project, a nominal bio-assay screening process will be used. If however, specific potential contaminants are identified, chemical analysis will be required.

3. For sites where some specific contaminate data are available or a commercial/ industrial site is involved, NOAA Screening Quick Reference Tables have been accepted by MDMR and Mississippi Department of Environmental Quality on a provisional basis. Additional or alternate chemical analysis may be required based upon site specifics ([http://response.restoration.noaa.gov/book\\_shelf/122\\_NEW-SQuiRTs.pdf](http://response.restoration.noaa.gov/book_shelf/122_NEW-SQuiRTs.pdf)).

## **7.2 Evaluation of Turning Basin Sediments**

Three of EA's sample sites (Section 5.0) close to the proposed Turning Basin Expansion (GH04-01/02-M, GH04-03-W, and GH04-03-DW) were checked for BU compatibility.

According to the results of the 10-day whole sediment toxicity testing (bioassay) for *Leptocheirus plumulosus*, none of these samples exhibited a 10-day mean percent survival rate that was statistically different from the reference sediment sample (EA 2006).

Methodology for the whole-sediment bioassays followed guidance other than the specified testing method recommended by the MDMR in the interim protocols (Test Method 100.4 EPA/600/R-04/025). Should these 10-day bioassay results be utilized in conjunction with the characterization data for the new work dredging material, concurrence from the MDMR regarding the similarity and acceptance of the methods and results may be necessary.

Of the three parameters listed as Analytical Analyses by the interim protocols (percent organic matter, total TOC, and total volatile solids), only TOC was analyzed by EA (2006). For all samples collected for each of the alternatives developed by EA (2006), the overall range in TOC was 0.29 percent to 2.08 percent. The TOC measured in the reference sediments was 0.91 percent. These data should be supplemented with testing that analyzes the other two parameters; however, based upon the results of the 10-day bioassay and TOC analyses, it is not expected that the sediments from the proposed Turning Basin Expansion footprint will exhibit characteristics that are prohibitive for BU.

## **7.3 Evaluation of Sediments Adjacent to the Existing West Pier**

In 2010, Anchor QEA conducted an analysis for the Port to determine if the soft sediment dredged material from the 24-acre area adjacent to the existing West Pier could be placed into the Deer Island BU site located in Harrison County, Mississippi (Anchor QEA 2010b).

The results of the testing (Tables 7-2 and 7-3) indicated that the sediments from this location at the Port were able to be placed at Deer Island.

The analyses included:

- 10-day bioassay testing (*L. plumulosus*, 2 to 4 millimeters [mm])
- Percent moisture
- Total volatile solids
- Organic matter content
- TOC

**Table 7-2**  
**Bioassay 10-Day Test Results (Anchor QEA 2010b)**

Sample	<i>L. plumulosus</i> Survival		<i>L. plumulosus</i> Initial Weight (mg)	<i>L. plumulosus</i> Final Weight (mg)	
	Reference	Site		Reference	Site
PG-B1	98%	98%	0.397	0.326	0.344
PG-B2	98%	94%	0.397	0.326	0.329

**Table 7-3**  
**Sediment Analytical Results (Anchor QEA 2010b)**

Test	PG-B1	PG-B2
Percent Moisture (%)	69.7	60.3
Total Volatile Solids (%)	6.28	4.84
Organic Matter (%)	9.30	6.60
Total Organic Carbon (%)	2.35	1.57

#### 7.4 Ocean Dredged Material Disposal Site Requirements

As defined by Section 103 of the Marine Protection Research Sanctuary Act (MPRSA) of 1972, ocean disposal shall be limited to dredged materials that meet the ocean dumping criteria published by the USEPA in Title 40 of the Code of Federal Regulations (CFR), Parts 220-228 (GPO 2012). The evaluation of dredged material for ocean disposal is conducted by the USACE—the permitting agency for the transportation of dredged material to the ocean for the purpose of disposal—and subject to USEPA review and concurrence.

USEPA and USACE have developed a tiered testing approach to evaluate the suitability of dredged material for ocean disposal. Guidance for the evaluation of dredged material under the MPRSA Section 103 program is provided in the *Evaluation of Dredged Material Proposed for Ocean Disposal - Testing Manual* (USEPA/USACE 1991). As stated in USEPA/USACE (1991), the four tiers for testing dredged material for ocean disposal are as follows:

- Tier 1 Evaluation of Existing Information
- Tier 2 Conservative Screening Tools
- Tier 3 Laboratory Bioassays
- Tier 4 Advanced Biological Evaluations

The Testing Manual (USEPA/USACE 1991) and ocean dumping regulations stress the use of effects-based-testing bioassays as evaluative tools necessary to determine suitability of material for ocean dumping. The evaluation of dredged material focuses on biological effects rather than the concentration of contaminants. Bioassay testing focuses primarily on the impact of the solid phase on the benthic environment. Material deposited on the seafloor has greater potential to cause impact to a smaller area for a longer period than the fraction of dredged material released to the water column.

To determine the suitability for ocean dumping, the dredged material for a proposed project is evaluated in a tiered process (Tiers 1, 2, and 3). Quantitative comparisons of the acceptable conditions (reference sediments) and potential effects of a dredged material indicate whether the dredged material in question causes a direct and specific biological effect under test conditions; such effects can indicate the potential to adversely affect the biological receptors at an ODMDS (USEPA/USACE 1991). If the results of the appropriate tests and evaluations show the proposed dredged material meets the criteria under 40 CFR 227, disposal of the material at an USEPA-designated or USACE-selected ODMDS is supported.

The following sections describe the Tier 1 evaluation process and present an initial evaluation based on current data. It is assumed that additional data will be gathered as part of the development of the EIS and will supplement the data used for this evaluation. While neither a complete Tier 2 nor a Tier 3 evaluation is performed as part of this DMMP, components relevant to these evaluations (i.e., bioassay test data) are discussed in other sections of this document.

#### **7.4.1 Tier 1 Evaluation Description**

A Tier 1 evaluation uses readily available information and includes an assessment of when the regulatory exclusions from testing are applicable. Information on the proposed dredging site, sediment grain size, and potential for contamination is used to determine whether the exclusion criteria are met; the exclusion criteria as stated in 40 CFR 227.13 (b) are as follows:

*(1) Dredged material is composed predominantly of sand, gravel, rock, or any other naturally occurring bottom material with particle sizes larger than silt, and the material is found in areas of high current or wave energy such as streams with large bed loads or coastal areas with shifting bars and channels;*  
*or*

*(2) Dredged material is for beach nourishment or restoration and is composed predominantly of sand, gravel or shell with particle sizes compatible with material on the receiving beaches; or*

*(3) when: (i) The material proposed for dumping is substantially the same as the substrate at the proposed disposal site; and*

*(ii) The site from which the material proposed for dumping is to be taken is far removed from known existing and historical sources of pollution so as to provide reasonable assurance that such material has not been contaminated by such pollution.*(GPO 2012)

Evaluation at successive tiers is based on more extensive and specific information that allows more comprehensive evaluations of the potential for environmental effects. Note that compliance with the ocean dumping regulations requires compliance with water quality criteria (WQC; Tier 2) and bioassays to assess toxicity in the water column (both liquid phase and suspended phase) and sediment and bioaccumulation in the sediment (Tier 3).

#### **7.4.2 Expansion Project Tier 1 Data Evaluation**

The SERIM provides guidance regarding the evaluation of dredged materials for ocean disposal (USEPA/USACE 2008). As outlined in the SERIM, the first step of a Tier 1 evaluation is the assessment of the exclusion criteria.

According to the first exclusion requirement, the dredged material should have particle sizes predominantly larger than silts, have no more than 12 percent fines, and must be found in areas with excessive current or high wave energy (USEPA/USACE 2008). Based on the characteristics of the sediment type and hydrodynamics at the Port, this exclusion criterion is not fulfilled. As discussed in Section 5, the majority of the material within the Project dredging footprint is silty and clayey. Moreover, the wave climate around the Port is generally mild and the tidal fluctuations do not create excessive current velocity.

The second exclusion requirement is regarding beach nourishment or restoration. This activity does not require the issuance of a Section 103 permit under MPRSA; therefore, the second criterion is “seldom, if ever, applicable” (USEPA/USACE 2008). The third exclusion criterion has two requirements that must be fulfilled: 1) the dredged material is substantially similar to the sediments at the ODMDS; and 2) the dredged material is located at a sufficient distance away from any potential sources of pollution. The two requirements will be discussed below.

As described in Section 5, Anchor QEA collected reference samples from the Turning Basin, the Gulfport Western ODMDS, and the Pascagoula ODMDS (Anchor QEA 2013). The reference samples were then analyzed and compared to determine the capability between Turning Basin and ODMDS sediments. The analysis included physical, chemical, and biological for sediment, site water, and tissue.

### **7.4.3 ODMDS Sediment Physical and Chemical Characteristics**

Based on the guidance provided in the SERIM, in order for sediments at the dredging site and the proposed placement areas to be “substantially” similar, both must have the same USCS group classification (USEPA/USACE 2008). As discussed in Section 5, previous investigations of the materials present at the Port show the sediments are predominantly silts and clays with moderate sand fractions.

For the existing Gulfport Western ODMDS, the Site Management and Monitoring Plan (SMMP) identifies a range for the silt and clay content of the sediments at these sites. Specifically the composition ranges from 22 to 91 percent silts and clays, which the SMMP

identifies as “comparable” to the dredging site, which in this case is the Gulfport Harbor (USEPA/USACE 2008). Additionally, the four SERIM recommended reference locations for the ODMDS range in sediment composition from 64.5 to 96.1 percent fines, and the material types are classified as either sandy silt or silt (USEPA/USACE 2008).

The available documentation for the sediment characteristics at the Pascagoula ODMDS includes the designation EIS prepared by the USEPA (1990) and the SMMP (USEPA/USACE 2008). The EIS noted that the silt and clay content of the ODMDS sediments range from 21 to 77 percent and while there is little apparent seasonal variation, the average sand fraction was slightly higher in the spring (USEPA 1990). The material types are similar to the four reference locations cited by the SERIM (USEPA/USACE 2008). Percent fines at these locations range from 11.2 to 92.4 percent and the overall material types are classified as silt, sandy silt, or silty sand.

The Anchor QEA sampling and analysis showed that the Gulfport Western and Pascagoula ODMDSs contained a high percentage of fines (Anchor QEA 2013). Table 7-4 summarizes the physical data for the Gulfport Western and Pascagoula ODMDS samples from the 2013 Anchor QEA report. All metals except cadmium were detected in the samples. The samples did not contain any organometallic compounds, SVOCs, PAHs, or pesticides. Because the sediment samples were similar in physical and chemical characteristics and generally lacking in containments of concern, both ODMDSs were determined to be suitable disposal options for the Turning Basin dredged material.

**Table 7-4**  
**ODMDS Physical Sediment Characteristics**

ODMDS	Percent		
	Sand	Silt	Clay
Gulfport Western	5.7	44.6	49.7
Pascagoula	2.7	28.6	68.7

#### **7.4.4 Sediment Contamination Assessment**

As suggested by the SERIM, the USEPA’s Envirofacts website (EPA 2013) and the U.S. Coast Guard’s National Response Center (NRC) website (Coast Guard 2015) were consulted to

assess previous spills or events that may have contributed to the contamination of sediments at the Port. Envirofacts provides up-to-date information regarding environmental compliance information for registered facilities. Reports were generated for registered facilities near the Port (Appendix B). Also, the USEPA Region 4 Superfund website (EPA 2015) was consulted for listed contaminated sites in the vicinity of the Port. The available information indicates there are no sites on the waterway or in close proximity in the surrounding upland areas that would adversely affect the sediments at the Port.

The NRC website provides access to a comprehensive database of reported incidents involving potential hazardous releases into the environment. Data reports for a 14-year period (2001 to 2014) were reviewed for incidents occurring in Gulfport, Mississippi, at the Port. The majority of incidents reported were due to sheen, discharge from a docked vessel (presumably bilge), or mechanical failure of a vessel. A single incident of radiation detected emanating from a container was reported; however, it was later discovered that the contents (silicon sand) gave a false reading of radiation (Coast Guard 2015). Table 7-5 summarizes incidents that were near the Port of Gulfport Anchorage Basin. This table was developed by filtering all of the yearly reports provided on the NRC website for incidents that were cataloged as occurring in Gulfport, Mississippi, and relating the Harbor, West Pier, or East Pier. The Navigation Data Center (NDC) (USACE, 2012) website was also reviewed to determine the vessel cargo shipped in and out of Port. In the early 1900s, the Port's initial use was for the export of raw and finished wood products. Transitioning into the 1960s, the Port's import and export activities expanded to include refrigerated containers of tropical fruits. Titanium dioxide is another major commodity handled by the Port facility. Table 7-6 provides a summary of domestic and foreign cargo receipts and shipments to the Port as of 2012 (USACE, 2012). Based on data from the NRC, no spills of any cargo of any type occurred during the period of review.





**Table 7-5  
NRC Incident Summary**

Date	Identification Number	Description	Type of Incident	Remedial Action Description	Federal Agency Notified
4/26/2001 6:45	564118	The caller stated that there is a spill under the pier.	Fixed	None	
6/19/2001 17:00	570126	The caller is reporting a release of material from his vessel due to packing gland on starboard side coming loose allowing water into the engine room.	Vessel	The crew pumped out vessel's engine area, and repacked the shaft. Crew deployed sorbent pads.	USCG Gulfport
7/12/2001 15:45	572764	A hydraulic hose on a tug boat ruptured causing hydraulic oil to spill onto the deck and into the Gulfport harbor.	Vessel	Booms applied, absorbents applied, material contained.	USCG
1/24/2002 14:45	592094	A lumber vessel was discovered dumping raw sewage into the Gulfport harbor.	Vessel	None	
3/21/2002 17:15	597281	The caller reported a release of 10 gallons of diesel from vessel due to tank overflow.	Vessel	Material contained, cleanup completed.	CG
3/21/2002 18:15	597283	Caller reporting a release of material due to a tank burping during fueling.	Vessel	Investigation underway, contractor has been hired, investigation underway.	Coast Guard in Gulfport
5/11/2002 8:00	603422	The material spilled out of the vessel Anthony Taylor due to unknown causes.	Vessel	None	Coast Guard
6/10/2002 19:15	609924	The fuel tank on a carrier vessel was overfilled causing diesel fuel to spill into the Gulfport harbor.	Vessel	Absorbents applied.	MSO Mobile
7/30/2002 6:25	618258	The caller is reporting an unknown sheen around the vessel "Nova Zelandia".	Unknown Sheen	None	USCG
6/29/2003 9:45	649391	The transfer hose on a vacuum truck failed causing waste oil to spill into the Gulfport harbor.	Mobile	Applied booms and absorbents.	USCG
8/12/2003 9:15	653660	Materials released from a vessel, due to an equipment failure.	Vessel	Clean up underway.	
11/10/2003 12:00	704901	Material released from a fuel tank vent on a cargo vessel (Dutch flag) due to unknown causes.	Vessel	Material contained, cleanup crew on-site.	
7/22/2004 11:30	729161	An unknown sheen was discovered in the Gulf Port harbor.	Unknown Sheen	None	USCG
9/28/2004 12:40	736625	The caller is reporting an unknown sheen.	Unknown Sheen	None	
1/10/2005 13:00	746709	Caller is reporting an unknown sheen in the water.	Unknown Sheen	None	CG
3/25/2005 10:16	753743	Caller stated release of oil from sound tube, cleaning their bilge and sounding tubes overflowed.	Vessel	Clean up underway, ship crew doing cleanup on site with booms.	
8/6/2005 19:45	768194	The caller is reporting the discovery of a diesel fuel sheen in the west Mississippi Sound coming from a grounded fishing vessel.	Vessel	None as of yet.	USCG
5/15/2009 10:00	905715	Caller stated that she was fishing with her husband and they noticed a large sheen in the Gulf of Mexico. Caller believed the sheen was coming from a crane that was doing work in the area.	Unknown Sheen	None	USCG
1/13/2010 8:45	928471	Caller stated this morning 13-Jan-2010 at the Port of Gulfport a radiation hit on a container was discovered. The Customs Boarder Protection personnel checked out the container and the port was shut down at 0755 hours until 0845 hours. The container in question contained silicon sand which gave a false reading of radiation. Caller stated there was no real hazard to the cargo. Caller stated there was no evacuation just a shutdown for fifty minutes until the container was checked out by Customs Boarder Protection at that point the gates were reopened. The reporting party was under the impression that Custom Boarder Protection called this incident into the National Response Center earlier today but there is not a report of this incident generated until now.	Storage Tank	The container was checked out by the Customs Border Protection.	Customs Border Protection
7/27/2011	983993	Caller reported an unknown substance floating in the water near the Port.	Unknown	None	USCG

Date	Identification Number	Description	Type of Incident	Remedial Action Description	Federal Agency Notified
4/3/2013	1042859	Caller reporting a collision that happened at dock. Caller stated that there was another vessel that made contact with a barge.	Vessel	None	USCG

Note:

1. None of the entries in this table have been altered from their original content in meaning or description.

**Table 7-6**  
**Port of Gulfport Domestic and Foreign Cargo (2012)**

Commodity	All Traffic Types (Domestic and Foreign)		
	All Traffic Directions (Short Tons)	Receipts (Short Tons)	Shipments (Short Tons)
Coal, Lignite, and Coal Coke	495	0	495
Petroleum and Petroleum Products	24,504	3,451	24,504
Chemicals and Related Products	38,589	4,785	33,804
Crude Materials, Inedible Except Fuels	419,843	377,316	42,527
Primary Manufactured Goods	355,055	8,612	346,443
Food and Farm Products	767,197	688,789	78,408
All Manufactured Equipment, Machinery	279,590	135,179	144,411
Waste Material; Garbage, Landfill, Sewage Sludge, Waste Water	0	0	0
Unknown or Not Elsewhere Classified	2,311	671	1,640
Total	1,887,584	1,215,352	672,232

#### **7.4.5 Additional ODMDS Sediment Testing**

In addition to the physical and chemical analyses for Tier 1 evaluation, Anchor QEA performed biological analysis of the Gulfport Western and Pascagoula ODMDS locations. The biological testing included solid phase, suspended particulate phase, and bioaccumulation tests.

As stated in Section 5 and the *Sampling and Analysis Report Gulfport Turning Basin* (Anchor QEA 2013), bioassay and bioaccumulation potential tests were conducted on three composite samples from the Dus and reference samples from the Gulfport Western and Pascagoula ODMDSs. Bioassay testing included two SP tests using *L. plumulosus* and *Nereis arenaceodentata*, two suspended particulate phase (SPP) tests using *Menidia beryllina* and *Americamysis bahia* (formerly *Mysidopsis bahia*), and one fertilization test using *Lytechinus pictus*. Results of the bioassay tests suggested that project sediment was not acutely toxic to aquatic organisms. Survivorship in the organisms (*Macoma nasuta* and *Nereis virens*) used for the bioaccumulation test was acceptable, and tissue samples were analyzed for arsenic and mercury concentrations. Arsenic and mercury concentrations in *M. nasuta* tissue

samples exposed to project sediment, as well as mercury concentrations in *N. virens* tissue samples, were not significantly greater than concentrations in tissue samples exposed to project reference sediment sample. Arsenic concentrations in *N. virens* tissue samples exposed to project sediment were significantly greater than arsenic concentrations in tissue samples exposed to project reference sediment; however, arsenic concentrations in *N. virens* tissues exposed to project sediment were at or below arsenic concentrations in day zero tissue samples. Further, mercury and arsenic measured in tissue samples from either organism were below the USFDA action levels (Anchor QEA 2013).

Based on the testing results, the Turning Basin sediment met the requirements for placement in the Gulfport Western or Pascagoula ODMDS.

#### **7.4.6 Expansion Project Tier 1 Data Evaluation Conclusions**

Available data were reviewed as part of a Tier 1 assessment to determine the suitability of the sediments from the Turning Basin Expansion area for ocean placement. The primary resource for the Tier 1 evaluation was the SERIM developed by the USEPA and USACE (2008). Of note, the SERIM does indicate that physical data used to compare and characterize the sediments at a particular site should not be more than 10 years old. Therefore, it is recommended that the final decision for material suitability be based on the data generated by the sediment characterization effort conducted to support the Expansion EIS, described earlier in this document (Anchor QEA 2013).

The data generated from this sediment characterization provides further proof of the similarity of the materials at the Project and ODMDS locations. The report for the sediment sampling at the Turning Basin Expansion provides a thorough comparison of sediments found at the Site and those found at each reference location. Additional testing to support Tier 2 and 3 evaluations was also conducted as part of the sediment characterization. These results provide sufficient information to determine final disposition of the sediments dredged from the Turning Basin Expansion area.

Based on the available data, there is no apparent evidence of contamination at the Port, and the sediments present at the Site and at the ODMDSs appear to be similar in physical and

chemical characteristics. The Tier 1 evaluation portion of this DMMP is considered complete until additional data prove otherwise.

---

## **8 DREDGED MATERIAL PLACEMENT ALTERNATIVES**

The DMMP reviewed BU sites and ODMDS locations for placement of the dredged material. As explained below, BU sites are the preferred method of placement. When placement in a BU site is not feasible, ODMDS may be considered as an alternative placement option. The following sections describe the proposed placement alternatives for BU sites and ODMDS locations.

### **8.1 Beneficial Use Sites**

The BU sites provide an alternative to traditional placement methods. Traditional dredged material placement methods typically discharge sediment into confined upland facilities or in open-water sites (i.e., thin-layer placement sites or ODMDS). Allocating dredged material for BU not only reduces the level of traditional placement disruptions, but when properly engineered, has environmental, economic, and social benefits. The use of dredged material for BU is legally mandated in several states, including Mississippi.

Sediment excavated as a result of dredging activities can be beneficially used in various ways such as engineering applications, environmental enhancement, and agricultural product uses (USEPA/USACE 2007a). The composition and grain size distribution of the material is an important consideration when evaluating the proposed site(s), delivery method(s), and overall project scope. Additionally, BU alternatives should evaluate other material and management aspects, which include, but are not limited to, contaminants, implementation, efficacy of proposed methods, environmental effects resulting from the dredging and placement, overall Project cost, and future maintenance.

The following sections discuss the legal requirement for BU in the State of Mississippi and present four potential BU sites listed in recent assessments of the Mississippi Gulf Coast region (CH2M HILL 2011a, 2011b). The referenced documents are consulted exclusively for the development of these sections, and unless otherwise noted, all information presented results from the review of these documents. In the event that these documents are altered, the content herein should be adjusted to reflect any alteration in intent, method, or location(s).



### **8.1.1 Mississippi Law**

The goal of BU for coastal Mississippi is to retain sediments “in the system” ensuring that dredged material that comes out of the Mississippi Sound is reused within the system (CH2M HILL 2011a). To facilitate keeping the sediments in the system, Mississippi passed Section 49-27-61 in July 2010. This law requires dredging activities generating over 2,500 CY to participate in appropriate BU programs, provided such material is suitable and a BU site is available.

### **8.1.2 Beneficial Use Permitting and Additional Considerations**

The MDMR establishes new BU sites and permits by county to ensure dredged material is used beneficially. Permitting new BU sites must be closely coordinated with the National Marine Fisheries Service (NMFS) and other regulatory agencies; new sites should be delineated to mitigate the impacts on critical habitat areas for the Gulf sturgeon. The projected sea level rise along the Mississippi Gulf Coast is another factor that should be considered when creating BU sites, as the design and construction of ancillary structures (containment dikes, breakwaters, etc.) should be able to provide the necessary protection of a BU site well into the future.

Proposed BU projects are to be submitted to the MDMR permitting office for review. The BU Program administrator will determine: 1) if it is feasible for the proposed site to receive dredged materials; and 2) if the site has sufficient capacity to accept the proposed dredged materials. If the site has sufficient capacity, the BU Program administrator will send approval to the permitting office. If the Plan does not identify a specific BU site, the BU Program administrator will review existing priority areas for consideration.

The MDMR Office of Coastal Management outlines the following four options for permit applicants who are involved in coastal projects that include dredging (CH2M HILL 2011a):

1. Designing and implementing a new BU project for the proposed dredged material.
2. Providing the dredged material in an approved coastal restoration project.
3. Applying the dredged material at alternative locations of equal BU.

4. Making a voluntary contribution to the Coastal Resources Trust Fund, based on the amount of material dredged. Such contributions from several smaller projects to the Coastal Resources Trust Fund can be combined to fund larger projects.

## **8.2 Available BU Sites and Capacities**

Ideally, the BU site(s) chosen for a particular project are in close proximity to the material source(s), thus creating an even balance between the efforts required for dredging, transport, and placement activities. By identifying BU sites, commercial dredging companies and agencies (e.g., USACE) are provided with several choices for material placement locations that include coastal restoration and enhancement project areas.

The BUs in the DMMP are limited to the Table 8-1 projects, which have been suggested by federal, state, and local authorities as possible designated BU sites in the Mississippi Gulf Coast region; site locations are displayed on Figure 8-1. If future BU sites are identified by the agencies, those BU sites may be evaluated and used for dredged material from the Project. For each of the suggested BU sites, Table 8-1 lists the estimated dredged material capacity, which is subject to change as the sites are permitted and additional data are collected. Many of the proposed BU sites identified in the table require containment structures to prevent erosion of the placed dredged material and breakwater structures for protection of the site during construction and post-restoration. For those BU sites, Table 8-1 lists the structure type and proposed length and estimated structure construction cost range. For the proposed sites that may not require additional structures, the cost ranges are “studies” costs, which include, but are not limited to, site topographic and/or bathymetric surveys, adjacent marsh and habitat evaluation, and dredged material suitability testing.

As noted in Table 8-1, information regarding BU at the Chandeleur Islands has been adapted from another report (T. Baker Smith [TBS] 2006), which documents the proposed construction and restoration of marshlands lost because of Hurricane Katrina; this report does not cite a quantity of material (or an estimated capacity) necessary to restore the islands. The available information provides a total land loss footprint (2,206 acres), which can be used to estimate the total placement coverage. The estimated dredging quantity (7.51 MCY) could provide a 2-foot-thick cover layer over the total land-loss footprint cited by TBS

(2006). This value is a generalization that assumes an even layer of dredged material placed across the entire area. It is likely that a thickness greater than this nominal value will be required to restore portions of the marshland at the Chandeleur Islands; therefore, this site may be able to receive additional dredged material.

**Table 8-1  
Identified BU Project Sites<sup>1</sup>**

Project	County	Capacity (CY)	Distance to Port of Gulfport (MI) <sup>2</sup>	Containment and Protection Structure Description and Length (LF)	Costs	
					Low	High
Biloxi Marsh Complex (BMC) (Louisiana)	N/A	Unlimited <sup>3</sup>	29	None Needed	\$100,000 (studies)	\$200,000 (studies)
Chandeleur Islands (Louisiana) <sup>4,5</sup>	N/A	Unknown	29 to 46	Design of Breakwater, Terminal Groins, Shoreline Armor Structures (unspecified length)	\$750,000	\$1,250,000
Bayou Caddy Marsh	Hancock	30,000	25	Temporary or None Needed	\$50,000 (studies)	\$150,000 (studies)
Bayou Caddy Safe Haven	Hancock	200,000	25	None Needed	\$50,000 (studies)	\$150,000 (studies)
Wolf River Marsh	Harrison	420,000	33	11,450 Riprap 5,700 Riprap/Deltalok 3,100 Temporary	\$3,000,000	\$4,000,000
Deer Island	Harrison	1,100,000	20	7,500 Earthen	\$1,500,000	\$3,000,000
Back Bay Marsh Island	Harrison	300,000	38	8,800 Riprap	\$4,600,000	\$6,100,000
Lake Mars Pier and Boat Launch	Jackson	39,000	23	None Needed	\$30,000 (studies)	\$100,000 (studies)
Lower Escatawpa	Jackson=	1,150,000	39	24,000 (Temporary): 12,000 Riprap, 12,000 Coir (if needed) or None Needed	\$50,000 (studies) \$3,924,000 temporary	\$150,000 (studies) \$5,472,000 temporary
Round Island	Jackson	3,300,000	38	5,000 Riprap	\$1,700,000	\$2,500,000

## Notes:

1. Unless noted otherwise, all information presented in this table is from the final Project Management Plan for Selected Beneficial Use Projects Along Coastal Mississippi (CH2M HILL 2011b).
2. The distance to the Port of Gulfport was measured along the existing channels; these distances should be considered approximate, as routes are subject to change based on vessel draft and traffic restrictions.
3. It is likely that further evaluation (bathymetric surveys) of the BMC will provide data that can be used to establish a capacity for this site.
4. Information for the Chandeleur Islands marsh restoration project is adapted from the T. Baker Smith report: *The Biloxi Marsh Stabilization and Restoration Plan* (2006).
5. The distance from the Port to the Chandeleur Islands is estimated based on the length of the island footprint assumed to receive dredged material.

### 8.3 Site Selection

From the information provided in Table 8-1, two criteria (estimated capacity and distance to the Port) were evaluated to select candidate BU sites for the Project's new work and maintenance dredged material. The only two sites listed that may be able to accommodate the estimated new work dredging volume are the Chandeleur Islands and the BMC, specifically the Northeastern Outlying Island. These two sites will be carried forward for further evaluation of new work dredging and placement costs.

For the Turning Basin and West Pier, North Harbor, and East Pier berthing areas maintenance dredging placement alternatives, candidate BU sites were also evaluated by estimated capacity, distance to the Port, and proposed containment and/or shoreline protection. Because maintenance materials typically have a higher moisture content than new work materials, sites with structural containment(s) may be necessary to consolidate the material and to prevent material erosion. Those BU sites with a containment and/or shoreline protection design and marsh restoration are believed to be the best candidates for the maintenance dredging material. The proposed BU site nearest the Port with sufficient capacity to accommodate at least one maintenance cycle is Deer Island. Deer Island will be carried forward for further evaluation of maintenance dredging and placement costs.

The three BU sites identified as candidates for the new work (Chandeleur Islands and BMC - Northeastern Outlying Island) and maintenance (Deer Island) materials are discussed further of the following sections. Descriptions of each site, along with their habitat value, stability, and sediment transport, are presented below.

### **8.3.1 Chandeleur Islands**

The Chandeleur Islands are a chain of barrier islands forming the easternmost point of the State of Louisiana. The federally owned island chain is part of the Breton National Wildlife Refuge (NWR), the second oldest refuge in the NWR System. The Chandeleur Islands were established in 1904 to provide sanctuary for nesting wading birds and sea birds as well as winter shorebirds and waterfowl (U.S. Fish and Wildlife Service [USFWS] 2006). The islands are the result of the westward shift of the Mississippi River (approximately 2,000 years ago), which discontinued the sediment supply to the St. Bernard delta region; in the subsequent years, the sediments remaining in this area contributed to the islands' formation (USFWS 2006).

#### **8.3.1.1 Habitat Value**

The majority of the Chandeleur Islands consist of sandy beach areas, which provide sufficient habitat for vegetation such as black mangrove, groundsel bush, and wax myrtle; additionally, the shallow, submerged shore areas support beds of manatee, shoal, turtle, and widgeon grass (USFWS 2006). According to the USFWS (2006), the habitat of the island area supports 23 species of shore and sea birds. Common nesting species include royal, caspian, and sandwich terns, laughing gull, the brown pelican, black skimmer, and during winter months, large numbers of waterfowl such as redheads, canvasback, and scaup frequent the islands (USFWS 2006).

#### **8.3.1.2 Site Stability**

According to TBS (2006), the Chandeleur Islands make up the largest barrier island in the Gulf of Mexico and protects the nearshore areas of Southeast Louisiana from storm surge and wave action resulting from tropical events. Because the day-to-day erosive forces (i.e., wind and wave action) and tropical events put the islands in a constant state of vulnerability, it may be necessary to construct coastal protection structures to provide additional site stability. Further analysis would be required to determine the alignment, material, and cross-section of these structures. Additionally, vegetative planting as part of the island restoration effort would contribute to the establishment and retention of critical habitat.

### **8.3.1.3      *Sediment Transport***

The islands are prone to erosion and have an average rate of shoreline loss of 44.3 feet per year. The post-Hurricane Katrina area of the islands is approximately 5,214 acres, which represents a 30 percent decrease from the islands' 2001 area (7,420 acres; TBS 2006). Previous analyses cited by TBS (2006) have shown that the islands experience cycles of land loss and gain, with most of the affected area on the Gulf side of the islands. However, as previously mentioned, the area experiences a net loss on a yearly basis.

### **8.3.2      *Biloxi March Complex – Northeastern Outlying Island***

Another BU site proposed within the Breton NWR and 210,000-acre BMC estuary is the Northeastern Outlying Island, which comprises approximately 30,290 acres and includes: islands, bays, and open-water lakes, specifically False Mouth Bay, Bay Boudreau, Drum Bay, and Shell Island Lake (CH2M HILL 2011b; TBS 2006). These areas are also portions of the St. Bernard delta region, established by sediment deposited by the Mississippi River prior to changing courses approximately 2,000 years ago.

#### **8.3.2.1      *Habitat Value***

The ecological functions of this area provide support for aquatic life in the region. This area of the BMC controls salinities for portions of the Mississippi Sound. Improvement of this area through BU would serve to enhance the fisheries of the surrounding areas, thus providing support to commercial and recreational fishermen (CH2M HILL 2011b).

#### **8.3.2.2      *Site Stability***

The stability at this site depends on the condition of the Chandeleur Islands. The Chandeleur Islands protect the Northeastern Outlying Island, which lies on the leeward side of the islands, from offshore waves. Restoration of the area would provide additional storm protection of the coastal region of Louisiana and Hancock County (CH2M HILL 2011b).

The conceptual restoration plan proposed by TBS (2006) in their evaluation suggested revegetating the site to provide stability and habitat establishment. As noted in Table 8-1, this area may not require containment or breakwater structures. However,



further evaluations of site conditions are required to: 1) determine the type(s) of vegetation necessary to recreate establish the habitat; and 2) determine the need for coastal protection structures for this site.

### **8.3.2.3      *Sediment Transport***

According to TBS (2006), the exposed lakes and bays of this area are prone to wave fetch on a daily basis, which increases the potential for erosion; between 2001 and 2005, approximately 1,297 acres of land were lost.

### **8.3.3      *Deer Island***

Deer Island, one of the first areas in coastal Mississippi to become a BU site, is located in southeast Harrison County (CH2M HILL 2011b). The island is composed of approximately 400 acres of land that is owned, managed, and monitored primarily by the MDMR (CH2M HILL 2011b).

#### **8.3.3.1      *Habitat Value***

The habitat within the island is varied and includes sandy beach along the shorelines and barrier island pond/lagoon complex, poly and mesohaline marsh, slash pine maritime forest, and relic dune scrub (CH2M HILL 2011b). The ecological function of this habitat variety serves to support migratory birds with feeding, resting, and wintering areas. The site is also home to a great blue heron rookery along with other bird species, including: brown pelican, sharp-shinned hawk, American kestrel, merlin, snowy plover, American oystercatcher, and least tern (CH2M HILL 2011b).

#### **8.3.3.2      *Site Stability***

Previous and ongoing projects at the site indicate the need for coastal structures to protect the material placement areas (LAW/GBA 2002; CH2M HILL 2011b). The island is positioned on the Mississippi Sound, with wave action impacting its southern face. However, because it is located in the nearshore area, Deer Island does receive some protection from the barrier islands.

### 8.3.3.3 *Sediment Transport*

A Deer Island geological study found that the shoreline retreat is approximately 2 acres per year, and since 1850, the island has lost more than 300 acres (Schmid and Otvos 2003). The loss rate is calculated from a comparison of the shoreline profiles and the resultant island footprint acreage. Additionally, Schmid and Otvos (2003) found that the erosion at the site is greatest at the southeastern corner of the island where muddy sands are the predominant material type. Originally, the southeastern corner of the island extended farther east and was called Little Deer; however, it has completely eroded away (CH2M HILL 2011b).

## 8.4 **Ocean Sites Available for Material Placement**

The USACE and other public and private entities use approved ocean disposal sites (i.e., ODMDS) when other open-water, BU, or upland placement options for dredged material are not feasible. Currently, there are three designated ODMDS locations (Gulfport Eastern, Gulfport Western, and Pascagoula) in the vicinity of the proposed Project. As previously discussed, the Gulfport Eastern ODMDS is no longer used by the USACE because the dredged material placed in the ODMDS migrates from the placement area into the FNC, which increases the necessity for maintenance dredging (CH2M HILL 2010a). Due to the likelihood of dredged material shoaling into the FNC, this ODMDS will not be included as part of the programmatic analysis of dredged material placement alternatives evaluated in Section 9.

After the submittal of the draft DMMP, the USACE informed the project team that the Gulfport Western ODMDS (Figure 8-1) permit had expired and would likely not be renewed. Therefore, the Gulfport Western ODMDS will no longer be considered a viable option for placement of the dredged material. The Pascagoula ODMDS will be the only ODMDS evaluated as a potential placement location for the dredged material from the Project. Available data regarding area, water depths, and placement activity (i.e., dates and quantities) were obtained from the USACE Ocean Disposal Database (USACE 2015) and the Pascagoula ODMDS Site Management and Monitoring Plan (SMMP).

### **8.4.1 Pascagoula ODMDS**

The Pascagoula ODMDS is located south of Horn Island on the western side of the Pascagoula Bar Channel (Figure 8-1) and was designated as an ODMDS in 1991. From 1976 to 1990, a portion of the area was used as an undesignated placement location. During this period, approximately 5.8 MCY were placed at the undesignated placement location. The existing Pascagoula ODMDS is approximately 32 square miles in area, with water depths varying from 38 feet in the north near Horn Island to greater than 52 feet along the southern boundary (USEPA/USACE 2006).

According to the USACE Ocean Disposal Database (USACE 2015), the Pascagoula ODMDS has been used for material placement as recently as 2013. Table 8-2 provides the placement date and quantities available from the database as of June 2015. The data show that this ODMDS is active and has received an average of 1.7 MCY every 16 months during the 1992 to 2013 time period. According to the database, the total material quantity placed at the site is approximately 28.6 MCY.

The SMMP (USEPA/USACE 2006) provides information on the dredged materials placed at the Pascagoula ODMDS from 1992 to 2005 indicates the following:

- The ODMDS is a highly dispersive site for fine materials.
- The fine-grained materials are typically found in the central and southern portions of the site; the remaining area consists of materials that are generally sandier material.
- Of the 11 placement events, 3 (1995, 2000, and 2001) consisted of new work materials; the remaining events were conducted for Operations and Maintenance (O&M) purposes.
- The material composition for the placement events varies. The new work dredging material consisted of a mixture of silts, clays, and sands. Four O&M dredging projects were identified as having placed sand at the site; the remaining four O&M events placed silts and clays or a mixture of material types at the site.
- The SMMP for the Pascagoula ODMDS does not specify a maximum placement quantity per year. Therefore, it is assumed that the amount of material disposed of at one time is not an issue for the Pascagoula ODMDS.

**Table 8-2**  
**Ocean Disposal Data – Pascagoula ODMDS**

<b>Year</b>	<b>Total Quantity</b>
1992	168,200
1993	607,400 (1,161,000)
1995	2,625,600 (2,650,000)
1996	3,291,200
1998	2,654,000 (1,600,000)
1999	414,200
2000	7,651,200 (7,700,000)
2001	3,494,700 (3,495,000)
2002	630,300 (630,000)
2003	1,097,500 (1,300,000)
2004	2,053,100 (1,009,000)
2005	120,000 (121,000)
2006	672,500
2008	1,489,100
2009	152,700
2011	248,726
2013	1,216,428

## Notes:

Quantities reported in this table are from the USACE Ocean Disposal Database and are supplemented with values from the SMMP (USACE/USEPA 2006); these values are given in parentheses.

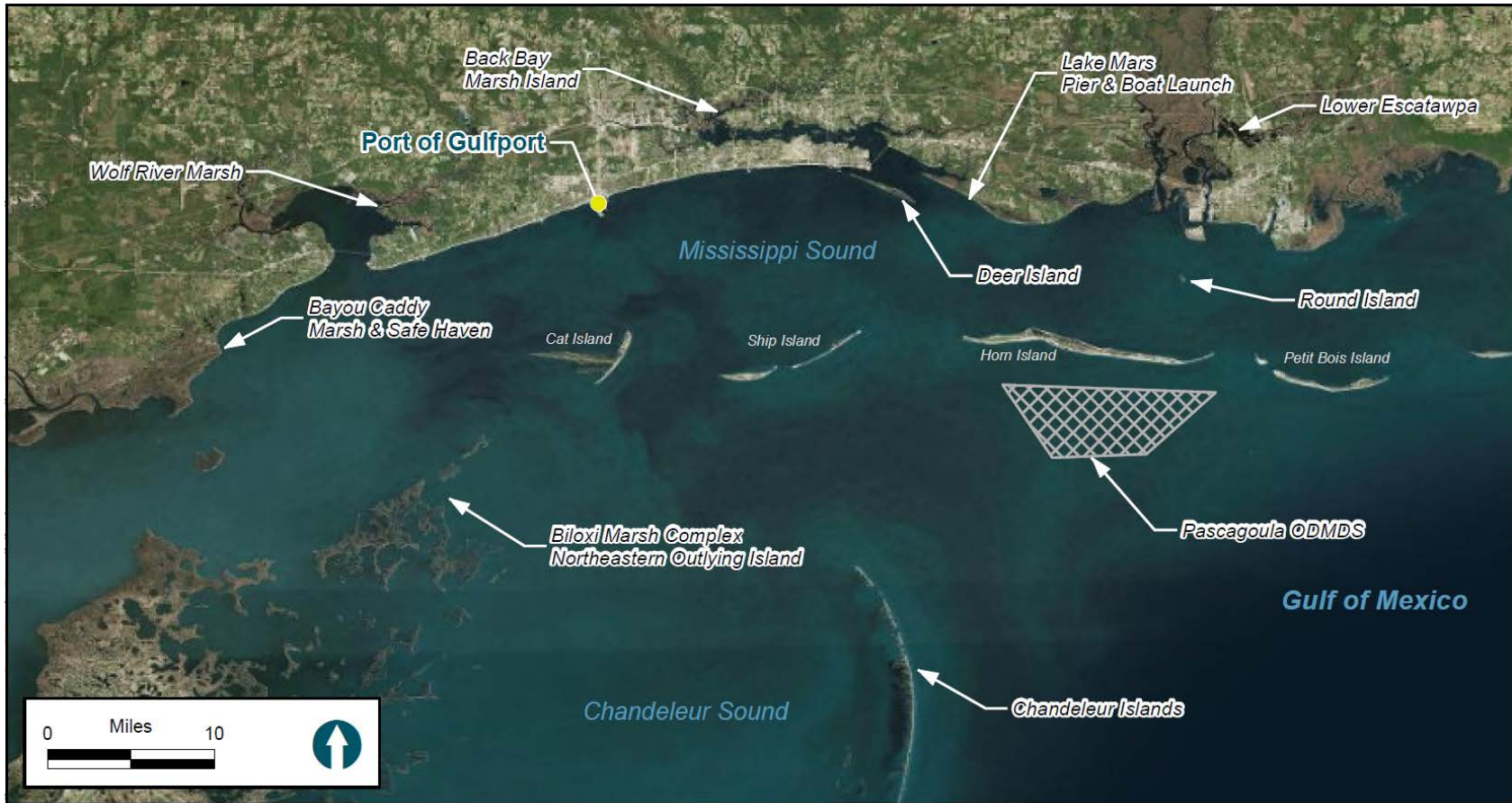

**Figure 8-1**  
**ODMDS and Beneficial Use Locations**

---

## **9 PROGRAMMATIC ANALYSIS OF PLACEMENT ALTERNATIVES: NEW WORK DREDGING**

The following sections present an evaluation of the placement alternatives for the dredging associated with the construction of the West and East Pier and the Turning Basin. Four alternatives were developed as placement options for the dredging associated with the West and East Pier Expansion and the Turning Basin creation.

Alternative evaluations for the new work material placement scenarios are based on a quantitative analysis of dredging and placement costs and available placement site capacity. Additionally, a general discussion of the habitat created for each BU alternative is presented. The discussion is qualitative only and does not attempt to predict the effects of habitat creation by any quantitative means; if necessary, such an evaluation may be incorporated as part of the Expansion EIS and a supplementary geotechnical evaluation.

### **9.1 Placement Alternatives**

#### **9.1.1 West Pier Terminal Expansion Fill**

Alternative 1 evaluates using the Turning Basin Expansion dredged material as fill for the proposed West Pier Terminal Expansion. This alternative assumes that the West Pier Terminal Expansion footprint will not be dredged prior to the placement of the material excavated from the Turning Basin Expansion.

An estimate of the fill necessary to construct the West Pier Terminal Expansion was calculated using the existing DEM of the Mississippi Sound region (NOAA 2008). Using the estimated dredging quantity for the Turning Basin Expansion and berthing facilities (4.55 MCY) and the estimated fill rate for the footprint (0.25 MCY per LF), an unconsolidated finished elevation of +4 to +7 feet MLLW was estimated. The consolidated foundation and dredged material finished elevation is likely below MLLW.

To keep the dredged material in the project area, dikes and temporary shore protection would be constructed prior to placing the Turning Basin Expansion dredged material into the West Pier Expansion footprint. Based on the current footprint dimensions and assuming a 3H:1V side slope, 20-foot crest width, finished elevation of +12 feet MLLW, and a displaced

toe to -20 feet MLLW, approximately 1.3 MCY of fill material would be needed to construct containment berms along the perimeter. Construction of the berms can be completed via barge-mounted excavator. A phased approach to the berm construction and fill placement is suggested to control mud waves and other associated impacts.

### **9.1.2 ODMDS Placement**

For Alternative 2, the dredged material would be placed in the Pascagoula ODMDS (Figure 9-1), as described in Section 8.4. The Pascagoula ODMDS is located 26 miles from the Port and west of the Pascagoula Bar FNC. The ODMDS has a surface area of 32 square miles and water depths ranging from 38 to 52 feet. The alternative assumes that the dredged materials would be mechanically dredged, loaded into bottom dump, split-hull hopper barges, and transported by tugboat to the Pascagoula ODMDS. The materials would then be dumped from the barges into the ODMDS in 2- to 3-foot lifts.

### **9.1.3 BU Placement: Chandeleur Islands**

BU placement in the Chandeleur Islands (Figure 9-1) is Alternative 3A. Because the islands are prone to erosion, restoration of these islands is needed to provide storm protection for coastal Louisiana. The islands also provide essential bird habitats and nesting grounds. For this alternative, it is assumed that the dredged material meets Louisiana and Mississippi regulations for BU and will be acceptable for restoration activities at the Chandeleur Islands.

The restoration of the islands can be accomplished by pumping dredged materials ashore to fill low-lying or submerged areas. The long-term goal of the dredged material placement is to encourage and enhance marsh development by increasing elevations in the marsh or restoring eroded marsh areas. Finished elevations of the placed dredged material will dictate the marsh species and habitat. Further marsh development activities (e.g., planting indigenous marsh grasses to mitigate erosion) are beyond the scope of this DMMP.

Based on the information presented in Section 8.3, the total estimated new work dredging quantity for the Pier and Turning Basin expansions could provide a 1.7-foot-thick cover layer over the total land loss footprint cited by TBS (2006). Assuming that portions of the restoration area (2,206 acres) are below the water surface elevation, it is recommended that



the low-lying areas of the upland portions of the site receive sediment before the fringes. Moreover, TBS (2006) recommends that further engineering actions (i.e., coastal structures) be erected on the islands as protective measures against extreme events; TBS cited a cost range of \$750,000 to \$1.25 million for the design effort. Based on previous experience, engineering design is typically 10 percent of the estimated construction cost. Therefore, the associated construction cost for shoreline protection may range from \$7.5 to \$12.5 million.

One third of the site was used in the 2011 channel widening contract, and recent aerial photography indicates that the area is highly dispersive and a significant capacity exists along the eastern shores of the island chain. Additional data, such as bathymetric and topographic surveys, will need to be collected to determine actual site capacity, proposed placement areas, and the need for coastal protection structures.

#### **9.1.4 BU Placement: BMC – Northeastern Outlying Island**

Alternative 3B is the second BU alternative site and is Northeastern Outlying Island in the BMC (Figure 9-1). As discussed in Section 8, the Northeastern Outlying Island is approximately 30,290 acres. The re-establishment of this portion of the BMC would serve two purposes: 1) increase coastal protection for Hancock County, Mississippi; and 2) enhance existing fisheries (CH2M HILL 2011b).

As of June 2015, the potential placement area in the Northeastern Outlying Island has been narrowed down to the Johnson Bay and Northwest Jack Williams Bay area. Restoration in this area can be accomplished by distributing dredged materials into the low-lying, submerged, and open-water areas. As with the Chandeleur Islands, the long-range goal of the BU site is to create mounds to encourage marsh habitat development, intertidal circulation, and habitat diversity. The need for containment structures due to oyster leases in the area will be evaluated during the permit process. For the purpose of the DMMP, this alternative assumes no containment structures will be necessary. Further marsh development activities may be necessary to complete the restoration activities (e.g., planting indigenous marsh grasses to mitigate erosion) and are not covered by this DMMP.

Additional data are necessary for the permitting and design phases of this alternative. Survey data are necessary to establish the actual capacity of the site and proposed placement (i.e., discharge) locations. For practical purposes, the site currently is considered to have an unlimited capacity, which will need to be verified prior to alternative selection. For costing the alternatives, it is assumed the capacity analysis will cost \$100,000 to \$200,000.

## **9.2 Cost Assessment**

A cost assessment for each of the alternatives involving new work dredging for the Port expansion is presented in Table 9-1. The total costs include a 30 percent contingency for construction costs. The gross unit cost represents the quotient of the total construction cost and the estimated dredging quantity. Additionally, mobilization and demobilization costs are estimated to be 19 percent of the total construction cost and are factored into this analysis.

**Table 9-1**  
**West and East Pier and Turning Basin Expansion Dredging Cost Summary**

<b>Alternative</b>	<b>Total Cost (\$ MIL)</b>	<b>Quantity (MCY)</b>	<b>Gross Unit Cost (\$/CY)</b>	<b>Description</b>
1 <sup>1</sup>	\$ 85.33	5.09	\$ 12.80	Mechanically dredge the Turning Basin Expansion footprint, East Pier Expansion footprint, West Pier Terminal Expansion berth area, and North Harbor Fill berth area, construct a containment berm for the dredged material along the perimeter of the West Pier Expansion footprint, and use the dredged materials as fill for the West Pier Terminal Expansion.
2	\$ 48.70	7.51	\$ 4.80	Mechanically dredge the Turning Basin Expansion footprint, East Pier Expansion footprint, West Pier Expansion footprint and berth area, and North Harbor Fill berth area; transport and place the dredged material at the Pascagoula ODMDS.
3A	\$ 57.28	7.51	\$ 5.90	Mechanically dredge the Turning Basin Expansion footprint, East Pier Expansion footprint, West Pier Expansion footprint and berth area, and North Harbor Fill berth area; transport and place the dredged material at the Chandeleur Islands BU site.
3B	\$ 56.12	7.51	\$ 5.80	Mechanically dredge the Turning Basin Expansion footprint, East Pier Expansion footprint, West Pier Expansion footprint and berth area, and North Harbor Fill berth area; transport and place the dredged material at the Biloxi Marsh Complex – Johnson Bay and Northwest Jack Williams Bay BU site.

Note:

1. Previous estimates for fill transport and placement range from \$17.00 to \$20.50 per CY (Anchor QEA 2010a). Therefore, Alternative 1 provides a potential cost savings ranging from \$4.20 to \$7.70 per CY.

### 9.3 Summary

As presented in Table 9-1, the cost for using the dredged material as fill for the West Pier Expansion footprint is substantially greater than the other three alternatives. The cost assessment for Alternative 1 includes the cost of material and labor necessary to construct a containment berm. However, Alternative 1 may provide considerable savings for the overall Project if the sediments dredged from the Turning Basin Expansion footprint and the existing substrate within the West Pier Expansion footprint are suitable foundation material or can be consolidated. The use of the dredged material would reduce the amount of off-site fill needed to construct the project and in turn reduce the costs of the overall project. To determine the actual cost benefit of this alternative, the cost analysis information must be evaluated alongside other cost assessments for filling the West Pier Terminal Expansion footprint with off-site materials.

The remaining three alternatives are similarly priced. Placement at the Pascagoula ODMDS (Alternative 2) is the lowest, as no additional equipment is required for placement or habitat development and restoration. Placement at the BU sites (Alternatives 3A and 3B) cost \$1.00 to \$1.10 more per CY than ODMDS placement but provides ecological and shoreline protection benefits that ODMDS placement is unable to provide.

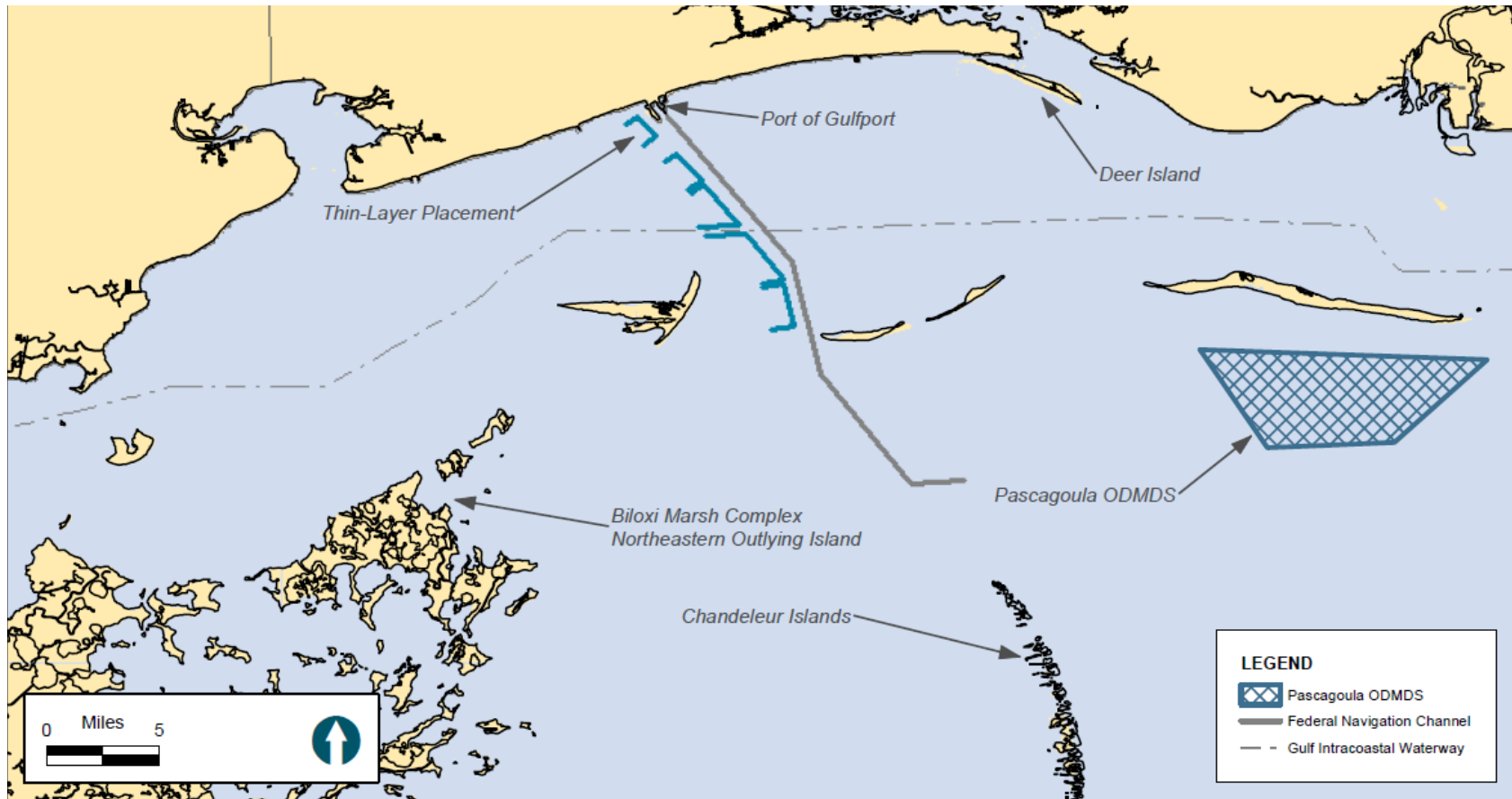

**Figure 9-1**  
**Proposed Placement Locations**

---

## **10 PROGRAMMATIC ANALYSIS OF PLACEMENT ALTERNATIVES: FUTURE MAINTENANCE DREDGING**

Section 10 presents an evaluation of the three placement alternatives for the maintenance dredging associated with the Turning Basin and West Pier, North Harbor, and East Pier berthing areas. Two of these alternatives include sites identified in Section 8, Deer Island in Section 8.3.3, and Pascagoula ODMDS in Section 8.4.1.

### **10.1 Placement Alternatives**

#### **10.1.1 Thin-Layer Placement**

Thin-layer placement is when dredged material are dispersed over a designated open-water bottom. Dredged material is transported to the placement area via discharge pipeline and dispersed by a “spill barge” in a single 6- to 12-inch lift over the surface area. In order to meet the water quality regulations, the spill barge is usually fitted with a diffuser at the end of the dredge discharge pipe. The diffuser is oriented such that the material is discharged at or below the water surface. This method is described in Subpart H Sec. 230.73 of the Section 404 (b)(1) *Guidelines for Specification of Disposal Sites for Dredged or Fill Material* (USEPA 1980) and has been implemented at numerous projects. Additionally, the requirement for dredging and placement for the coastal areas of Mississippi is that turbidity must not exceed 50 Nephelometric Turbidity Units (NTU) above background outside of the permitted 750-foot mixing zone around the placement areas/discharge location.

The Port typically uses the available open-water D/As adjacent to the upper Sound Channel (Figure 10-1) as placement areas for the dredged maintenance material. These areas are available for thin-layer placement of maintenance materials only. The 60-year FNC project history indicates that the open-water D/As on the western side of the channel (1, 3, 5, 7, and 9) have sufficient capacity, which is restored via the predominant east-to-west Mississippi Sound currents. The restored capacity should accommodate the future maintenance needs of the Port. Although the USACE does not use the northern portion of D/A 1 because of pumping distances from the FNC and impacts to the Commercial Small Craft Harbor during dredging events, it has adequate vertical capacity for future maintenance events at the Port with water depths varying from 6 to 20 feet. Dredged material placed in this northern area of the historic D/A footprint would migrate off the site and supply the nearshore areas to the

west. Placement in the nearshore area would begin to offset the net erosion observed by USACE in their studies (Rosati et al. 2009) and would comply with the intent of the Mississippi BU law (MS Code 49-27-61) to keep the materials within the system. The southern part of D/A 1 was removed from the regular FNC maintenance dredging material placement cycle, as it has reached its maximum capacity (elevation -4 feet MLLW).

The analysis of this alternative assumes maintenance dredging of the proposed Turning Basin Expansion and West Pier, North Harbor, and East Pier berthing areas using a hydraulic cutterhead dredge. The BD surveys of the Turning Basin Expansion and West Pier, North Harbor, and East Pier berthing areas and BP surveys of the open-water D/A(s) selected to receive the maintenance material will be data necessary prior to each maintenance dredging event. Depending on the capacities of these sites, more than one D/A may be necessary to accommodate the estimated quantity; this determination cannot be made until BP surveys for the areas are completed. Because the Port frequently uses the open-water placement areas for maintenance-dredged materials, it is expected that continuing to maintain the existing permits for these sites will not be an issue for future dredging events, especially because no historical contaminant or bioaccumulation impacts are documented.

### **10.1.2 Beneficial Use Placement**

The maintenance materials could be placed in the proposed BU sites described in the *Final Project Management Plan for Selected Beneficial Use Projects along Coastal Mississippi* (CH2M HILL 2011b). This application is different from typical maintenance dredging events at the Port, as it may require the construction of containment dikes and breakwaters. As such, complete funding for the construction and establishment of a given BU site may not be available for a single maintenance dredging event; therefore, a phased approach for these sites should be considered. Currently, Deer Island appears to be the only site in proximity to the Port listed in the *Final Project Management Plan for Selected Beneficial Use Projects Along Coastal Mississippi* (CH2M HILL 2011b) that has the capacity for a single maintenance event. Because using BU sites further from the Port is more expensive and not a feasible option, they were not evaluated as part of the programmatic analysis.

Deer Island is located off the coast of Biloxi, Mississippi, and has previously received sediments for BU along the southeastern corner of the island. The MDMR has recently issued a permit allowing the placement of additional sediments in the original containment area constructed under a USACE contract (DACW21-98-D-002S/CK1104; LAW/GBA 2002) in 2002 and for the construction of a new containment dike adjacent to the existing placement area.

CH2M HILL (2011b) proposed the following BU activities at Deer Island:

- Restoring the island to the historic 1850 footprint by filling the southern shoreline along the length of the island with an estimated 1.1 MCY of sediment
- Constructing a 7,500 LF earthen containment dike at the southwestern corner of the site

Restoration would provide additional marsh habitat and protection for the island, and the increased island footprint would provide the mainland coastline further protection from tropical events.

The cost for construction of the containment dike is estimated to range from \$1.5 to \$3.0 million (CH2M HILL 2011b); additional studies of the sediment drift along the island's southern shore may be necessary—these studies are not included in the above construction costs. Bathymetric and topographic condition surveys of the restoration area will be necessary prior to Project implementation to determine the appropriate dike alignment and verify the site's capacity.

### **10.1.3 ODMDS Placement**

In this alternative, the Pascagoula ODMDS, discussed in Section 8.4.1, would be the placement location for the dredged maintenance material from the Turning Basin and the West Pier, North Harbor, and East Pier berthing areas. Because the Pascagoula ODMDS is a dispersive site, it is assumed that the ODMDS is capable of handling the 30-year maintenance dredging volumes for the Turning Basin and the berthing areas.



The analysis of this alternative assumes the Turning Basin Expansion and berth maintenance dredging will be accomplished by mechanical dredging, and the dredged sediments will be transported to the site via tugboat and split-hull hopper barges.

## 10.2 Turning Basin and Berth Cost Assessment

A cost assessment for each of the three alternatives involving maintenance dredging of the Turning Basin and West Pier, North Harbor, and East Pier berths is presented in Table 10-1. A contingency of 30 percent is added to the construction cost to provide the total cost, which is listed in the second column of the table. The gross unit cost represents the quotient of the total construction cost and the dredging quantity. Additionally, mobilization and demobilization costs are assumed to be 19 percent of the total construction cost and are factored into this analysis.

**Table 10-1**  
**Turning Basin and Berths Maintenance Dredging Cost Summary**

Alternative	Total Cost (\$ MIL)	Quantity (MCY)	Gross Unit Cost (\$/CY)	Description
1	\$ 3.40	1.26	\$ 2.10	Hydraulically dredge the Turning Basin Expansion and berth areas, and place dredged material via thin-layer dispersal method in open-water placement sites.
2	\$ 19.44	1.26	\$ 12.10	Mechanically dredge the Turning Basin Expansion and berth areas, construct containment dikes at Deer Island, and transport and place dredged material at Deer Island BU site.
3	\$ 8.71	1.26	\$ 5.20	Mechanically dredge the Turning Basin Expansion and berth areas, and transport and place dredged material at the Pascagoula ODMS.

## 10.3 Summary

Thin-layer placement in the available open-water D/As presents the least expensive option for maintenance dredging of the Turning Basin and West Pier, North Harbor, and East Pier berthing areas because less construction equipment and distance are required for placement.

As documented in the MsCIP studies (Rosati et al. 2009), the northern 70 percent of D/A 1 is not used for USACE FNC maintenance and would provide a placement area that would feed the areas west of the Port. The cost for placement at the Pascagoula ODMDS is not significantly higher, but it introduces more risk. Placement at the ODMDS assumes that the tugboats and barges will be operating on a 24-hour schedule with minimal downtime; equipment failure and adverse weather would have a significant effect on the Project's timing.

The Deer Island BU alternative is the most expensive as a result of the following:

1. Construction of a containment dike prior to the first dredging event
2. Access
3. Implementation of offloading methods to aid in marsh development

All subsequent maintenance costs would only include dredging, transport, and offloading, which result in a gross unit cost of approximately \$9.10 per CY; inflation is not factored into this analysis.

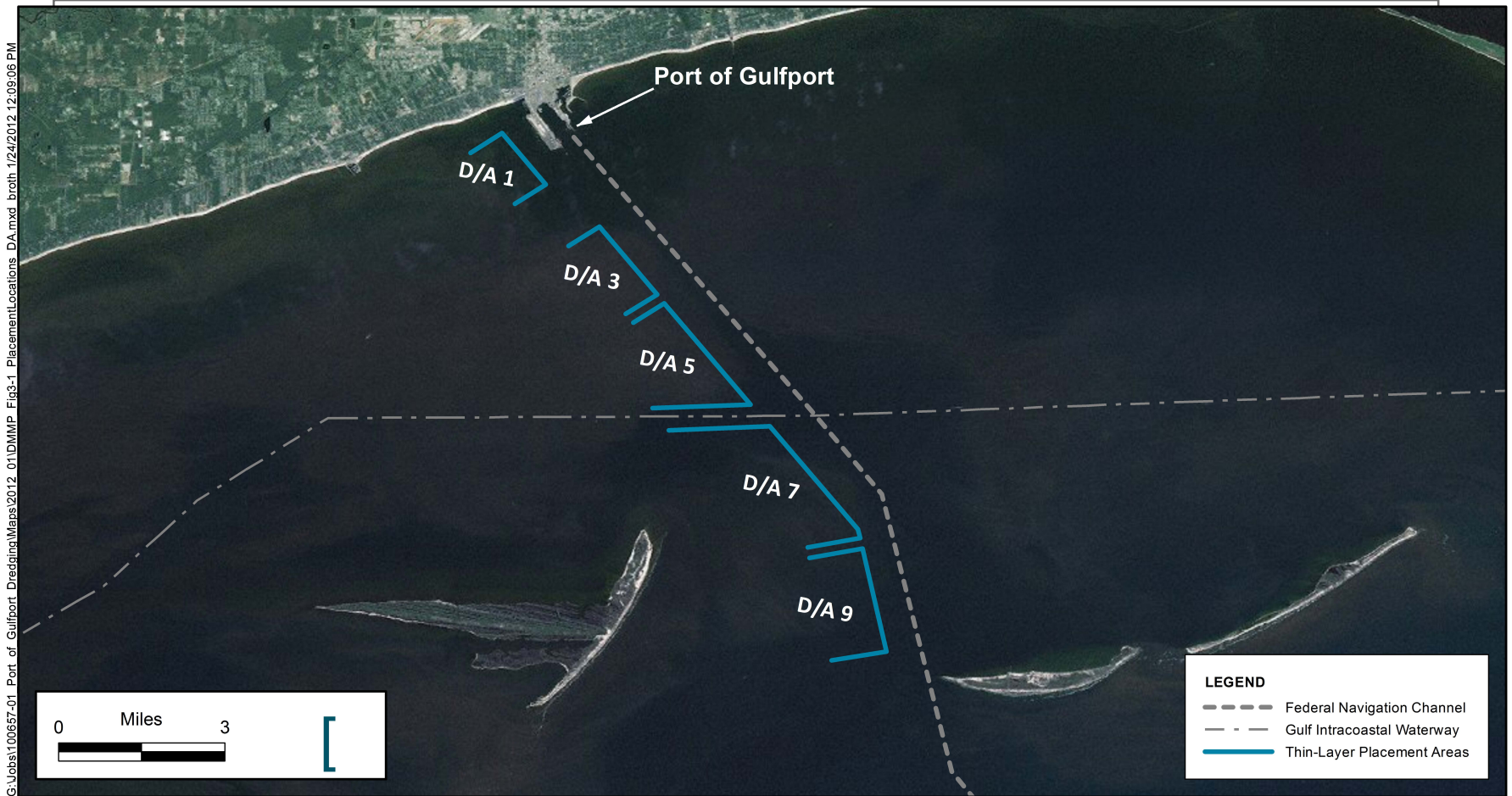

**Figure 10-1**  
**Thin-Layer Placement Areas**

---

## 11 SUMMARY AND RECOMMENDATIONS

The goal of this DMMP is to collect and present historical dredging and sediment characterization data; outline the existing permits; analyze dredged material placement alternatives; and present sediment characteristic information for the BU and ODMDS placement areas for the Port Expansion Project.

Alternatives presented for placement of West and East Pier and Turning Basin dredged material include:

- West Pier Terminal Expansion structural fill
- Pascagoula ODMDS
- Chandeleur Islands BU
- BMC - Northeastern Outlying Island BU

Alternatives presented for placement of the Turning Basin and West Pier, North Harbor, and East Pier berthing areas maintenance materials include:

- Open-water D/As
- Deer Island BU
- Pascagoula ODMDS

Tables 11-1 and 11-2 provide a summary and screening matrix of each alternative. The conclusions presented in these tables are based on the current alternatives analysis and the data available to support each alternative.

### 11.1 New Work Dredging Summary

Using the dredged material in the West Pier Expansion construction (Alternative 1) has the potential to reduce the overall costs of the Port Expansion if the dredged material is found to be suitable as fill material. However, a comprehensive geotechnical analysis and the associated West Pier construction costs are necessary to make a complete evaluation of this alternative. Using the dredged material as fill also introduces a considerable amount of uncertainty, as it is not currently known whether the existing substrate will need to be excavated prior to construction.

Alternative 2 (ODMDS placement) provides the lowest cost and the least amount of uncertainty for the new work dredging. The BU alternatives (3A and 3B) present the most significant potential for habitat development and restoration, which should be considered when determining the ultimate goal for new work material placement. However, to evaluate the BU sites as dredged material placement locations, survey and habitat investigations need to be performed at the sites to determine site capacities and placement locations.

## **11.2 Turning Basin and Berth Maintenance Dredging Summary**

For the maintenance dredging, Alternative 1, thin-layer placement, is the least expensive of the three alternatives. The Port currently has permits for and uses the thin-layer placement areas for maintenance dredged material. In addition, using the open-water sites for dredged material placement allows the sediment to remain in the Mississippi Sound because it is bypassed in the direction of the net littoral drift.

The Deer Island BU (Alternative 2) has the potential to provide considerable habitat and protection benefits to coastal Mississippi. However, Deer Island does not provide a long-term placement option for the 30-year maintenance of the Turning Basin Expansion and would be filled to capacity (1.1 MCY) after one maintenance event. Existing condition and capacity data collection, permitting, design, and containment construction would also need to occur prior to using Deer Island as a placement site.

As documented in the USACE MsCIP sediment transport studies (Rosati et al. 2009), the best option for a longer-term BU placement scenario would be to develop and sequence the maintenance events in order to feed materials into the longshore system. Even if additional BU alternatives are developed in the future, thin-layer and ODMDS placement should be retained as placement alternatives to account for tropical and subtropical events that have historically deposited large volumes of material in Anchorage Basin and the Port berthing areas.

Alternative 3 (Pascagoula ODMDS) is less expensive than Alternative 2 and is currently available for placement of dredged material. However, placement of dredged material at the

Pascagoula ODMDS does not meet the Mississippi BU law and does not provide a substantial habitat or protection benefit to coastal Mississippi.

**Table 11-1  
West and East Pier and Turning Basin Expansion Alternatives Screening Matrix<sup>1,2,3</sup>**

<b>Evaluation Criteria</b>	<b>Alternative 1 West Pier Expansion Fill</b>	<b>Alternative 2 Pascagoula ODMDS Placement</b>	<b>Alternative 3A Chandeleur Islands</b>	<b>Alternative 3B Biloxi Marsh Complex - Northeastern Outlying Island (Johnson Bay and Northwest Jack Williams Bay)</b>
Accessibility	High - The fill site is adjacent to the Turning Basin Expansion dredging area	High - The placement site is located in open water and easily accessible	High - The site is adjacent to the Gulf of Mexico and the Chandeleur Sound	Medium - The exterior portions of the site are accessible; however, interior areas may be too shallow to reach with the equipment needed
Additional Construction	Yes - The West Pier Expansion material containment dike will be integrated into the construction; a phased approach is suggested so that fill and dike construction can be executed simultaneously	None	None	None
Estimated Capacity <sup>4,5</sup>	Not Applicable	Not Applicable	Unknown	No Capacity Limit
Contribution to Project	Potentially accelerates project timeline by creating the Turning Basin Expansion and beginning the West Pier Expansion simultaneously; utilization of new work materials as fill would provide cost savings to the Project	Provides for a phased approach to the Project; construction of the West Pier Expansion will follow Turning Basin Expansion	Provides for a phased approach to the Project; construction of the West Pier Expansion will follow Turning Basin Expansion	Provides for a phased approach to the Project; construction of the West Pier Expansion will follow Turning Basin Expansion
Estimated Cost (\$ Million)	\$84.06	\$46.07	\$56.35	\$55.21
Currently Available	No - Expansion permit (SAM-2009-1768-DMY) has been approved; Notice of Intent to prepare an EIS has been submitted, but EIS has not been completed	Yes - The Pascagoula ODMDS has been designated and is active	No - Further coordination between Mississippi and Louisiana agencies is necessary to permit this area for BU	No - Further coordination between Mississippi and Louisiana agencies is necessary to permit this area for BU
Distance from Port <sup>6,7</sup>	Not Applicable	20 to 30 miles	29 to 46 miles	29 miles
Estimated Construction Duration <sup>8</sup>	32 months	23 months	23 months	23 months
Existing Site Information	Medium - Additional characterization and stability analyses are necessary prior to filling atop the existing material at the site	High - SMMPs and available designation EIS reports fully document the site	Low - Documentation associated with the Mississippi BU program does not provide information on the site; investigation is necessary prior to method selection	Medium - Documentation associated with the Mississippi BU program provides information on the site; investigation is necessary prior to method selection

Evaluation Criteria	Alternative 1 West Pier Expansion Fill	Alternative 2 Pascagoula ODMDS Placement	Alternative 3A Chandeleur Islands	Alternative 3B Biloxi Marsh Complex - Northeastern Outlying Island (Johnson Bay and Northwest Jack Williams Bay)
Habitat Benefit <sup>9</sup>	None	Low - Material placed at the ODMDS would be lethal to benthic organisms; fish, shrimp, squid, and crabs would be temporarily displaced from the area	High - Considerable habitat benefit; this area is home to various species; restoration will also provide additional barrier island protection for the coast	High - Considerable habitat benefit; this area is home to various species; restoration will also provide additional barrier island protection for the coast
Risk	Medium - This alternative requires further analysis of the existing sediment bearing capability; multiple marine construction efforts would occur simultaneously and vessels at the Port may be affected; additional analyses for West Pier Expansion construction are necessary; previously accomplished at other Gulf ports.	Low - This method of placement is routine	High - Many data gaps are present: capacity, existing conditions survey, acceptable material type, need for coastal structures; coordination between Louisiana and Mississippi agencies may cause delays	Medium - Data gaps are present: capacity and existing conditions survey; coordination between Louisiana and Mississippi agencies may cause delays

Notes:

1. EIS - Environmental Impact Statement
2. ODMDS – Ocean Dredged Material Disposal Site
3. BU - Beneficial Use
4. Because the ODMDS is a dispersive site, it is assumed that capacity is maintained by tidal currents transporting materials off site.
5. Capacity limit for the Northeastern Outlying Island is based on the Project Management Plan for Selected Beneficial Use Projects Along Coastal Mississippi (CH2M HILL 2011b).
6. Distances from the Port to the placement areas were estimated using the current channel alignments. It is possible that the distances shown could be altered based on the route chosen to access a certain placement site.
7. The distance from the Port to the Chandeleur Islands is estimated based on the length of the island footprint assumed to receive dredged material.
8. The estimated duration for the beneficial use does not include time required for permitting or site investigation activities.
9. Information regarding the habitat and environmental response at the ODMDS is provided in the draft EIS (CH2M HILL 2010a).



**Table 11-2**  
**Maintenance Alternatives Screening Matrix<sup>1,2,3,4,5</sup>**

Evaluation Criteria	Alternative 1 Thin-Layer Placement	Alternative 2A Deer Island	Alternative 3 Pascagoula ODMDS Placement
Accessibility	High - The placement areas are adjacent to the Sound Channel and the Port	High - The site is located in Harrison County off the coast of Biloxi; the navigation channel leading to Back Bay is adjacent to the island	High - The placement site is located in open water and easily accessible
Additional Construction	None	Yes - 7,500 LF of containment dike is necessary to complete the restoration at the southeastern end of the site along the Little Deer shoreline	None
Estimated Capacity <sup>6,7</sup>	Not Applicable	1.1 million cubic yards	Not Applicable
Estimated Cost (\$ Million)	\$3.24	\$18.74	\$8.30
Currently Available	Yes - These sites are used regularly for maintenance dredging events, including the north end of D/A 1	No - Official site designation has not occurred, but is expected prior to Project execution	YES - The ODMDS has been designated and is active
Distance from Port <sup>8</sup>	Not Applicable	20 miles	30 miles
Estimated Construction Duration <sup>9</sup>	20 days	4 months	4 months
Existing Site Information	High - Open-water placement areas are well-documented and regularly used	High - The site has been utilized for previous BU projects; documentation associated with the Mississippi BU program provides information on the site; investigation is necessary prior to method selection	High - SMMP and available designation EIS reports fully document the site
Habitat Benefit <sup>10,11</sup>	Medium to High - Additional characterization and stability analyses are necessary prior to filling atop the existing material at the site; material and nutrients are kept in the system	High - Considerable habitat benefit; this area is home to various species; restoration will also provide additional protection for the coast	Low - Material placed at the ODMDS would be lethal to benthic organisms; fish, shrimp, squid, and crabs would be temporarily displaced from the area
Risk	Low - This method of placement is routine for the maintenance events in the area; future assessments of the capacities of each of the placement areas may be needed	Medium - Data gaps are present: existing conditions survey; the containment dike would need to be fully designed and constructed prior to the maintenance dredging event	Low - This method of placement is routine

Notes:

1. EIS - Environmental Impact Statement
2. ODMDS – Ocean Dredged Material Disposal Site
3. BU - Beneficial Use
4. GIWW - Gulf Intracoastal Waterway
5. LF- Linear Feet
6. Because the ODMDS is a dispersive site, it is assumed that capacity is maintained by tidal currents transporting materials off site.
7. Capacity limits for the Deer Island BU site is are based on the *Final Project Management Plan for Selected Beneficial Use Projects Along Coastal Mississippi* (CH2M HILL 2011b).
8. Distances from the Port to the placement areas were estimated using the current channel alignments. It is possible that the distances shown could be altered based on the route chosen to access a certain placement site.
9. The estimated duration for the BU alternatives does not include time required for permitting, site investigation activities, or construction of containment dikes and breakwaters.
10. Information regarding the habitat and environmental response at the ODMDS is provided in the draft EIS (CH2M HILL 2010a).
11. It is assumed that the thin-layer and ODMDS placement methods will result in the same biological effects to the benthic organisms at the sites.



### **11.3 Recommendations**

The recommended dredged material placement alternatives associated with the new work (West and East Pier Expansion and Turning Basin creation) and the Turning Basin and West Pier, North Harbor, and East Pier berth maintenance dredging are presented in Section 11.3.

For permitting, the DMMP must identify placement areas for the dredged material. Because of this requirement, the recommendations below only consider current viable placement areas. If additional BU sites are permitted prior to the final Expansion Project design, the Port will evaluate the additional BU sites and their capacities as part of the final design and may use the newer BUs for placement areas instead of the alternatives listed below.

#### **11.3.1 Placement of New Work Dredging Material**

The recommended placement alternative for the dredged material from the West and East Pier Expansion and Turning Basin creation is a permitted BU site such as the BMC - Northeastern Outlying Island and Chandeleur Islands sites. During the DMMP evaluation, the Port began discussions with the MDMR/USACE Beneficial Use Group (BUG) on using the BMC - Northeastern Outlying Island as a placement area for dredged material from the Port and FNC expansion. The BUG was in favor of a BU site instead of the ODMDS because the BU site would meet the preferred Mississippi placement method, provide additional shoreline protection, and create essential wildlife habitat. Based on favorable consideration by the BUG, the MDMR is proceeding with permitting the BMC - Northeastern Outlying Island as a BU site, which is the recommended placement alternative for the new work material.

After the submittal of the 2013 DMMP, a pre-application meeting was held on August 6, 2014, with the MSPA, Mississippi Development Authority, MDMR, USACE (Mobile and New Orleans Districts), USEPA, NOAA Fisheries, Louisiana Department of Environmental Quality, Louisiana Department of Natural Resources, Louisiana Office of State Lands, Louisiana Coastal Protection and Restoration Authority, Louisiana Department of Wildlife and Fisheries, and St. Bernard Parish. The agencies were in favor of using the Port Expansion Project dredged material to restore the BMC. The location of the proposed

BU has been narrowed to the Johnson Bay and Northwest Jack Williams Bay area of the BMC - Northeastern Outlying Island.

Although the Pascagoula ODMDS is not the preferred placement area for the West and East Pier Expansion and the Turning Basin creation, it is a viable placement alternative. If BU sites are not available or viable for dredged material placement, the dredged material could be placed in the Pascagoula ODMDS.

### **11.3.2 Placement of Turning Basin and Berth Maintenance Dredging Material**

The recommended placement option for the Turning Basin and West Pier, North Harbor, and East Pier berth maintenance dredged material is thin-layer placement in the available open-water D/As. The D/As, currently used by the USACE and the Port, present the lowest total Project cost and the least amount of risk of all the proposed alternatives. Placement at the Pascagoula ODMDS is also a viable option for future maintenance material; however, this option is more costly, as the material must be transported off site for placement.

Additionally, this placement method removes materials from the sediment processes within the estuary.

---

## 12 REFERENCES

- Anchor QEA (Anchor QEA, LLC), 2010a. *Alternative Fill Sources – Port of Gulfport 24 Acre Site and Subsequent Fill Events*. Memorandum Prepared for: Mississippi State Port Authority – Port of Gulfport, November 2010.
- Anchor QEA, 2010b. *Final Environmental Testing Report*. Prepared for: Mississippi State Port Authority – Port of Gulfport, December 2010.
- Anchor QEA, 2011. *Technical Report Storm Surge Analysis*. Prepared for: Mississippi State Port Authority – Port of Gulfport, March 2011.
- Anchor QEA, 2013. *Sampling and Analysis Report Gulfport Turning Basin*. Prepared for: Mississippi State Port Authority – Port of Gulfport, April 2013.
- Baker (Michael Baker Jr., Inc.), 2011. *East Breakwater Configuration Alternatives*. Prepared for: Mississippi State Port Authority – Port of Gulfport. September 2011.
- Byrnes, M.R., J.D. Rosati, and S.F. Griffee, 2011. *Littoral Sediment Budget for the Mississippi Sound Barrier Islands*. Prepared for: U.S. Army Corps of Engineers, Mobile District. June 2011.
- CH2M HILL, 2010a. *Draft Environmental Impact Statement Gulfport Offshore Ocean Dredged Material Disposal Site Designation*. Prepared for: USACE, Mobile District. June 2010.
- CH2M HILL, 2010b. *The Plan for the Implementation of the Port of Gulfport Restoration Program*. Prepared for: Port of Gulfport. August 2010.
- CH2M HILL, 2011a. *Final Master Plan for the Beneficial Use of Dredged Material for Coastal Mississippi*. Prepared for: Gulf of Mexico Alliance/Habitat Conservation and Restoration Team. July 2011.
- CH2M HILL, 2011b. *Final Project Management Plan for Selected Beneficial Use Projects Along Coastal Mississippi*. Prepared for: Gulf of Mexico Foundation and Mississippi Department of Marine Resources. September 2011.
- Coast Guard (U.S. Coast Guard), 2015. National Response Center Reports. Accessed on June 18, 2015. Available from: <http://www.nrc.uscg.mil/Default.aspx>.

- EA (EA Engineering, Science, and Technology), 2006. *Sediment Quality Characterization of the Gulfport Harbor Federal Navigation Channel*. Prepared for: USACE, Mobile District. January 2006.
- Federal Register, 2011. *Intent to Prepare an Environmental Impact Statement for the Port of Gulfport Expansion Project, Harrison County, MS*. 76:48 (11 March, 2011) p. 13363.
- GPO (U.S. Government Publishing Office), 2012. 40 CFR 227.15 – Dredged Materials. Accessed: July 8, 2015. Available from: <http://www.gpo.gov/fdsys/granule/CFR-2012-title40-vol26/CFR-2012-title40-vol26-sec227-13>
- LAW (LAW Engineering and Environmental Services, Inc.) and GBA (Gahagan & Bryant Associates), 2002. *Final Design Plans and Specifications for Marsh Creation Containment System at Deer Island*. Prepared for USACE, Mobile District. DACW21-98-D-0025/CK1104. August 2002.
- McAnally, W.H., C. Friedrichs, D. Hamilton, E. Hayter, P. Shrestha, H. Rodriguez, A. Sheremet, and A. Teeter, 2007a. Management of Fluid Mud in Estuaries, Bays, and Lakes. I: Present State of Understanding on Character and Behavior. *Journal of Hydraulic Engineering* 133:1(9).
- McAnally, W.H., A. Teeter, D. Schoellhamer, C. Friedrichs, D. Hamilton, E. Hayter, P. Shrestha, H. Rodriguez, A. Sheremet, and R. Kirby, 2007b. Management of Fluid Mud in Estuaries, Bays, and Lakes. II: Measurement, Modeling, and Management. *Journal of Hydraulic Engineering* 133:1(23).
- MS Code (Mississippi Code), 2013. Title 49 – Conservation and Ecology, Chapter 27 – Coastal Wetlands Protection Act, 49-27-61 – Charges for materials removed under permit; alternative for dredged material disposal. Accessed: May 8, 2013. Available from: <http://law.justia.com/codes/mississippi/2013/title-49/chapter-27/section-49-27-61>.
- MSPA (Mississippi State Port Authority at Gulfport), 2015. *Facilities*. Accessed: July 27, 2015. Available from: <http://shipmspa.com/carriers-customers/facilities/#sthash.vS3aUTnR.dpbs>.
- NOAA (National Oceanic and Atmospheric Administration), 2008. *Digital Elevation Model of Biloxi, Mississippi: Procedures, Data Sources and Analysis*. National Geophysical

- 
- Data Center, Marine Geology and Geophysics Division. NOAA Technical Memorandum NESDIS NGDC-9. January 2008.
- Otvos, E.G., and M.J. Giardino, 2004. Interlinked barrier chain and delta lobe development, northern Gulf of Mexico. *Sedimentary Geology* 169:47-73.
- Rosati, J.D., M.R. Byrnes, M.B. Gravens, and S.F. Griffee, 2009. *Mississippi Coastal Improvement Project (MsCIP) Study Regional Sediment Budget for Mississippi Mainland and Barrier Island Coasts*. Prepared for USACE, Engineer Research and Development Center, Coastal and Hydraulics Lab (ERDC-CHL). TR-09-X. July 2009.
- TBS (T. Baker Smith), 2006. *The Biloxi Marsh Stabilization and Restoration Plan*. Prepared for: Biloxi Marsh Lands Corporation. June 2006.
- Thompson (Thompson Engineering, Inc.) and URS (URS Corporation), 2003. *Sediment Characterization Analyses, Proposed West Pier Expansion Dredging*. Prepared for Mississippi State Port Authority at Gulfport. August 2003.
- Schmid, K., and E. Otvos, 2003. *Deer Island, Coastal Mississippi – A Geological and Historical Story* (Presentation). Available from:  
[http://geology.deq.state.ms.us/coastal/Pubs\\_Presentations.htm](http://geology.deq.state.ms.us/coastal/Pubs_Presentations.htm).
- Upshaw, C.F., W.B. Creath, and F.L. Brooks, 1966. *Sediments and Microfauna off the Coasts of Mississippi and Adjacent States*. Mississippi State Geological Survey Bulletin 106. 127pp.
- USACE (U.S. Army Corps of Engineers), 2002. Depth Measurement Over Irregular or Unconsolidated Bottoms. Ch. 21, *Hydrographic Survey Manual*. EM 1110-2-1003. January 2002.
- USACE, 2011. Port of Gulfport Dredging History Cards (1960 to Present). USACE, Mobile District. Data received: August 12, 2011.
- USACE, 2012. USACE Navigation Data Center. Accessed: June 17, 2015. Available from: [http://www.navigationdatacenter.us/wcsc/webpub12/Part2\\_Ports\\_tonsbycommCY2012.HTM](http://www.navigationdatacenter.us/wcsc/webpub12/Part2_Ports_tonsbycommCY2012.HTM).
- USACE, 2015. Pascagoula ODMDS Ocean Disposal Database. Accessed: June 17, 2015. Available from:

- <http://el.erdc.usace.army.mil/odd/DisposalSearchData.cfm?SiteID=43&RangeTermValue=NA>
- USACE, Mobile District, 1976. *Draft Environmental Impact Statement*, Gulfport Harbor Channel Deepening Navigation, Harrison County, Mississippi. Mobile, Alabama.
- USACE Mobile District, 1992. *Letter to: Great Lakes Dredge & Dock Company and Gulf Coast Trailing Company*. Regarding: Notice to Proceed for Contract Number DACW01-92-C-0060 (IFB DACW01-92-B-0038) Gulfport Harbor Deepening Gulfport, Mississippi. April 29, 1992.
- USACE Mobile District, 2009a. *Recovery - Indefinite Delivery Indefinite Quantity for Gulfport Harbor Channel Improvements and Other Mobile District Projects*. Issue Date: August 14, 2009.
- USACE Mobile District, 2009b. *Letter to: Mississippi State Port Authority at Gulfport*. Regarding: Department of the Army Draft Permit Number SAM-2009-00433-JBM. September 11, 2009.
- USFWS (U.S. Fish and Wildlife Service), 2006. *Breton National Wildlife Refuge (Pamphlet)*. August 2006. Available from: <http://www.fws.gov/southeast/pubs/BretonGeneral.pdf>.
- USEPA (U.S. Environmental Protection Agency), 1980. 40 CFR Part 230 Section 404(b)(1)– Guidelines for Specification of Disposal Sites for Dredged or Fill Material. December 1980. Accessed: July 9, 2015. Available from: [http://water.epa.gov/lawsregs/rulesregs/cwa/upload/CWA\\_Section404b1\\_Guidelines\\_40CFR230\\_July2010.pdf](http://water.epa.gov/lawsregs/rulesregs/cwa/upload/CWA_Section404b1_Guidelines_40CFR230_July2010.pdf)
- USEPA, 1990. *Draft Environmental Impact Statement Pascagoula Harbor Ocean Dredged Material Disposal Site Designation*. Prepared by: USEPA Region IV. EPA-904-1990.2. July 1990.
- USEPA, 2013. Envirofacts. Available from: <http://www.epa.gov/enviro/index.html>
- USEPA, 2015. Region 4 Superfund Sites. Accessed July 9, 2015. Available from: <http://www.epa.gov/region4/superfund/sites/sites.html#ms>.
- USEPA/USACE, 1991. *Evaluation of Dredged Material Proposed for Ocean Disposal*. EPA 503/8-91/001. February 1991.



- USEPA/USACE, 2006. *Pascagoula Ocean Dredged Material Disposal Site – Site Management and Monitoring Plan*. May 2006.
- USEPA/USACE, 2007a. *Identifying, Planning, and Financing Beneficial Use Projects Using Dredged Material*. EPA 842-B-07-001. October 2007.
- USEPA/USACE, 2007b. *Ocean Dredged Material Disposal Memorandum of Understanding*. April 30, 2007.
- USEPA/USACE, 2008. *Southeast Regional Implementation Manual (SERIM) Requirements and Procedures for Evaluation of the Ocean Disposal of Dredged Material in Southeastern U.S. Atlantic and Gulf Coast Waters*. EPA 904-B-08-001. February 1991.
- USEPA/USACE, 2009. *Gulfport West & East Ocean Dredged Material Disposal Sites – Site Management and Monitoring Plan*. September 2009.
- Welp, T., 2011. Nautical Depths for Corps Navigation Projects (Presentation). 2011 U.S. Army Corps of Engineers Infrastructure Systems Conference. Atlanta, Georgia. June 2011. Available from: <[http://www.usace-isc.org/presentation/HHC%20-%20Coastal/Nautical%20Depth\\_Welp\\_2.pdf](http://www.usace-isc.org/presentation/HHC%20-%20Coastal/Nautical%20Depth_Welp_2.pdf)>.



APPENDIX A  
PORT OF GULFPORT  
USACE MAINTENANCE DREDGING PERMIT





REPLY TO  
ATTENTION OF

**DEPARTMENT OF THE ARMY**  
MOBILE DISTRICT, CORPS OF ENGINEERS  
P.O. BOX 2288  
MOBILE, AL 36628-0001

August 7, 2009

Coastal Branch  
Regulatory Division

SUBJECT: Department of the Army Draft Permit Number SAM-2009-00433-JBM, Mississippi State Port at Gulfport

Mississippi State Port  
at Gulfport  
Attention: Mr. John Webb  
Post Office Box 40  
Gulfport, Mississippi 39501

Dear Mr. Webb:

Enclosed are two copies of a Department of the Army draft permit for work specified in accordance with the enclosed plans, drawings, and specifications. If the permit is acceptable as drafted, you are requested to sign both copies in the space indicated and return both signed copies to me for final action. The original will be signed by me and returned to you with a placard to be posted at all times that construction is performed at the site.

This permit is not valid until it is properly signed by both the applicant and me; therefore, work must not commence on the project until a fully-executed copy has been returned to you.

Your attention is directed to all conditions under which this permit will be issued. Failure to comply with any condition of the approved permit may result in its suspension, cancellation, or revocation. If you object to certain terms and conditions contained within the permit, you may request that the permit be modified. Enclosed you will find a Notification of Administrative Appeal Options and Process fact sheet and Request for Appeal (RFA) form. If you choose to object to certain terms and conditions of the permit, you must follow the directions provided in Section 1, Part A and submit the completed RFA form to the letterhead address.

In order for an RFA to be accepted by the U.S. Army Corps of Engineers (Corps), the Corps must determine that it is complete, that it meets the criteria under 33 CFR Part 331.5, and that it has been received by the District office within 60 days of the date of the RFA. Should you decide to submit an RFA form, it must be received at the letterhead address by within 60 days of the date of this letter.



REPLY TO  
ATTENTION OF:

**DEPARTMENT OF THE ARMY  
U.S. ARMY ENGINEER DISTRICT, MOBILE DISTRICT  
CORPS OF ENGINEERS  
P.O. BOX 2288  
MOBILE, ALABAMA 36628-0001**

September 11, 2009

Coastal Branch  
Regulatory Division

SUBJECT: Department of the Army Draft Permit Number SAM-2009-00433-JBM, Mississippi State Port at Gulfport

Mississippi State Port  
at Gulfport  
Attention: Mr. John Webb  
Post Office Box 40  
Gulfport, Mississippi 39501

Dear Mr. Webb:

**PLEASE READ THIS LETTER CAREFULLY AND COMPLY  
WITH ITS PROVISIONS**

There is enclosed a Department of the Army permit authorizing you to perform the work specified therein in accordance with the plans shown on the drawings attached thereto. This permit is issued under provision of the Federal laws for the protection and preservation of the navigable waters of the United States. These laws provide that after the proposed work has been approved by issuance of a Department of the Army permit,

**IT SHALL NOT BE LAWFUL TO DEVIATE FROM SUCH PLANS EITHER  
BEFORE OR AFTER COMPLETION OF THE WORK,**

unless modification of said plans has previously been submitted to and received the approval of the Department of the Army.

You should study and carefully adhere to all the terms and conditions of the permit. The District must be notified of the commencement and completion of the permitted work. The enclosed cards may be used for that purpose. Also enclosed is a "NOTICE OF AUTHORIZATION" which must be conspicuously displayed at the site during construction of the permitted work.

If for any reason it becomes necessary to make a material change in location or plans for this work, revised plans should be submitted promptly to the District Engineer in order that the revised plans may receive the approval required by law before work is begun.

Compliance with this and other conditions of the permit is essential. Failure to submit the notices requested may result in its revocation.

Please contact me at (251) 690-2658, if you have any questions. For additional information about our Regulatory Program, visit our web site at: [www.sam.usace.army.mil/rd/reg](http://www.sam.usace.army.mil/rd/reg). Please take a moment to complete our customer satisfaction survey while you're there. Your responses are appreciated and will allow us to improve our services.

Sincerely,

A handwritten signature in black ink that reads "Linda T. Brown". The signature is written in a cursive style with a large initial "L".

Linda T. Brown  
Team Leader, Coastal Mississippi  
Regulatory Division

Enclosures

**DEPARTMENT OF THE ARMY PERMIT**

Permittee: **MISSISSIPPI STATE PORT AT GULFPORT**

Permit No.: **SAM-2009-00433-JBM**

Issuing Office: **MOBILE DISTRICT**

NOTE: The term "you" and its derivatives, as used in this permit, means the permittee or any future transferee. The term "this office" refers to the appropriate district or division office of the Corps of Engineers having jurisdiction over the permitted activity or the appropriate official of that office acting under the authority of the commanding officer.

You are authorized to perform work in accordance with the terms and conditions specified below.

**Project Description: Maintenance dredge 200,000 cubic yards of material over a 10-year period from the Gulfport Harbor and the Gulfport Commercial Small Craft Harbor including the entrance channel. The areas to be dredged and the project depths are shown on the enclosed drawings. Material will be dredged by hydraulic and mechanical methods. Hydraulically dredged material will be placed in the Federal Project Mississippi Sound open water disposal sites utilizing thin layer disposal techniques. Mechanically excavated material will be placed in the Harrison County Development Commission upland disposal areas C-1 and C-2. No wetlands or submerged aquatic vegetation will be impacted. The purpose of the project is to provide sufficient water depths for vessel access to the port's docks which are adjacent to the Federal authorized project. This is a request to reauthorize work permitted by Department of the Army permit MS96-02521-U, which expired in December 2006.**

- ATTACHED:**
1. Vicinity map
  2. 10-Year Maintenance Dredging Plan
  3. Cross Sections A & B
  4. Cross Sections C & D
  5. Cross Section E
  6. Cross Section F
  7. Open Water Disposal Area Plan.
  8. Upland Disposal Area Vicinity Map
  9. Upland Disposal Area Site Plan
  10. Mississippi Department of Marine Resources Coastal Program Certification dated 17 June 17 2009
  11. Mississippi Department of Environmental Quality Water Quality Certification dated 3 August 2009
  12. Permit Condition Requirements for Disposal in Open Waters
  13. National Marine Fisheries Service's Biological Opinion F/SER.2007/02307, dated 9 July 2007

**Project Location: The project is located on Mississippi Sound, Gulfport, Harrison County, Mississippi (Lat. 30.356° N, Long. 89.091° W).**

Permit Conditions:

General Conditions:

1. The time limit for completing the work authorized ends on 7 AUGUST 2019. If you find that you need more time to complete the authorized activity, submit your request for a time extension to this office for consideration at least 1 month before the above date is reached.
2. You must maintain the activity authorized by this permit in good condition and in conformance with the terms and conditions of this permit. You are not relieved of this requirement if you abandon the permitted activity, although you may make a good faith transfer to a third party in compliance with General Condition 4 below. Should you wish to cease to maintain the authorized activity or should you desire to abandon it without a good faith transfer, you must obtain a modification of this permit from this office, which may require restoration of the area.



3. If you discover any previously unknown historic or archeological remains while accomplishing the activity authorized by this permit, you must immediately notify this office of what you have found. We will initiate the Federal and State coordination required to determine if the remains warrant a recovery effort or if the site is eligible for listing in the National Register of Historic Places.
4. If you sell the property associated with this permit, you must obtain the signature of the new owner in the space provided and forward a copy of the permit to this office to validate the transfer of this authorization.
5. If a conditioned water quality certification has been issued for your project, you must comply with the conditions specified in the certification as special conditions to this permit. For your convenience, a copy of the certification is attached if it contains such conditions.
6. You must allow representatives from this office to inspect the authorized activity at any time deemed necessary to ensure that it is being or has been accomplished in accordance with the terms and conditions of your permit.

Special Conditions: **a. All activities authorized by this permit shall be conducted in accordance with other local, State and Federal laws and regulations to protect the environment (e.g. Mississippi Department of Environmental Quality stormwater construction regulations and Section 401 Water Quality Certification requirements).**

**b. Best management practices shall be implemented to minimize erosion, siltation and damage to adjacent wetlands and waters of the United States. Appropriate erosion and siltation control measures must be used and maintained in effective operating condition during construction. All temporary erosion control features shall remain in place until permanent stabilization measures have been completed and have become fully effective.**

**c. All fill activities shall be performed in a manner that minimizes disturbance and turbidity increases in "waters of the United States" and wetlands; and shall be retained in a manner to preclude its erosion into any adjacent wetlands or waterway.**

**d. The permittee shall perform before and after-dredging surveys of the work area. The surveys shall extend 200 feet into the Federal Navigation Channel from the limits of dredging. Sounding shall be on intervals of 25 feet in 2 principle directions. Both surveys shall be controlled from a common baseline (horizontally) and a common vertical datum (mean sea level, mean low water, National Geodetic Vertical Datum, etc.). Surveys shall be in plan view or cross-section and show the limits of the Federal Channel. Surveys shall be taken within a 2-week interval of starting and completing dredging. The before-dredging surveys shall be submitted to the Mobile District for review and approval prior to dredging. The after-dredging survey shall be provided to the Mobile District within 30 days of completion. The surveys will be used to compare before and after-dredging water depths in the Federal Channel. If the permittee's work results in shoaling, they will be responsible for restoring the Federal Channel to the pre-dredging depths.**

**e. The permittee shall comply with the attached document titled *Mississippi State Port Authority Permit Condition Requirements for Disposal in Open Waters* (copy attached). Thin layer disposal is limited to open water sites 1, 3, 5, 7 and 9 or as directed by the Mobile District.**

**f. The permittee understands and agrees that, if future operations by the United States require the removal, relocation, or other alteration, of the structure or work herein authorized, or if, in the opinion of the Secretary of the Army or his authorized representative, said structure or work shall cause unreasonable obstruction to the free navigation of the navigable waters, the Permittee will be required, upon due notice from the U.S. Army Corps of Engineers, to remove, relocate, or alter the structural work or obstructions caused thereby, without expense to the United States. No claim shall be made against the United States on account of any such removal or alteration.**

**g. The permittee shall comply with the National Marine Fisheries Service's Biological Opinion F/SER.2007/02307, dated July 9 2007 (copy attached).**

Further Information:

1. Congressional Authorities: You have been authorized to undertake the activity described above pursuant to:

**(X) Section 10 of the Rivers and Harbors Act 1899 (33 U.S.C. 403).**

**(X) Section 404 of the Clean Water Act (33 U.S.C. 1344).**

2. Limits of this authorization.

a. This permit does not obviate the need to obtain other Federal, State, or local authorizations required by law.

b. This permit does not grant any property rights or exclusive privileges.

c. This permit does not authorize any injury to the property or rights of others.

d. This permit does not authorize interference with any existing or proposed Federal project.

3. Limits of Federal Liability. In issuing this permit, the Federal Government does not assume any liability for the following:

a. Damages to the permitted project or uses thereof as a result of other permitted or unpermitted activities or from natural causes.

b. Damages to the permitted project or uses thereof as a result of current or future activities undertaken by or on behalf of the United States in the public interest.

c. Damages to persons, property, or to other permitted or unpermitted activities or structures caused by the activity authorized by this permit.

d. Design or construction deficiencies associated with the permitted work.

e. Damage claims associated with any future modification, suspension, or revocation of this permit.

4. Reliance on Applicant's Data: The determination of this office that issuance of this permit is not contrary to the public interest was made in reliance on the information you provided.

5. Reevaluation of Permit Decision. This office may reevaluate its decision on this permit at any time the circumstances warrant. Circumstances that could require a reevaluation include, but are not limited to, the following:

a. You fail to comply with the terms and conditions of this permit.

b. The information provided by you in support of your permit application proves to have been false, incomplete, or inaccurate (See 4 above).

c. Significant new information surfaces which this office did not consider in reaching the original public interest decision.

Such a reevaluation may result in a determination that it is appropriate to use the suspension, modification, and revocation procedures contained in 33 CFR 325.7 or enforcement procedures such as those contained in 33 CFR 326.4 and 326.5. The referenced enforcement procedures provide for the issuance of an administrative order requiring you to comply with the terms and conditions of your permit and for the initiation of legal action where appropriate. You will be required to pay for any corrective measures ordered by this office, and if you fail to comply with such directive, this office may in certain situations (such as those specified in 33 CFR 209.170) accomplish the corrective measures by contract or otherwise and bill you for the cost.

6. Extensions. General condition 1 establishes a time limit for the completion of the activity authorized by this permit. Unless there are circumstances requiring either a prompt completion of the authorized activity or a reevaluation of the public interest decision, the Corps will normally give favorable consideration to a request for an extension of this time limit.

Your signature below, as permittee, indicates that you accept and agree to comply with the terms and conditions of this permit.

*[Handwritten Signature]*

*8/18/09*

(PERMITTEE) **MISSISSIPPI STATE PORT AT GULFPORT  
POST OFFICE BOX 40  
GULFPORT, MISSISSIPPI 39501**

\_\_\_\_\_  
(DATE)

This permit becomes effective when the Federal official, designated to act for the Secretary of the Army, has signed below.

**BYRON G. JORNS  
COLONEL, DISTRICT COMMANDER**

BY: *Linda T. Brown*  
**LINDA T. BROWN**  
**Team Leader, Coastal Mississippi  
Regulatory Division**

*14 Sep 2009*

\_\_\_\_\_  
(DATE)

When the structures or work authorized by this permit are still in existence at the time the property is transferred, the terms and conditions of this permit will continue to be binding on the new owner(s) of the property. To validate the transfer of this permit and the associated liabilities associated with compliance with its terms and conditions, have the transferee sign and date below.

\_\_\_\_\_  
(TRANSFEREE)

\_\_\_\_\_  
(DATE)

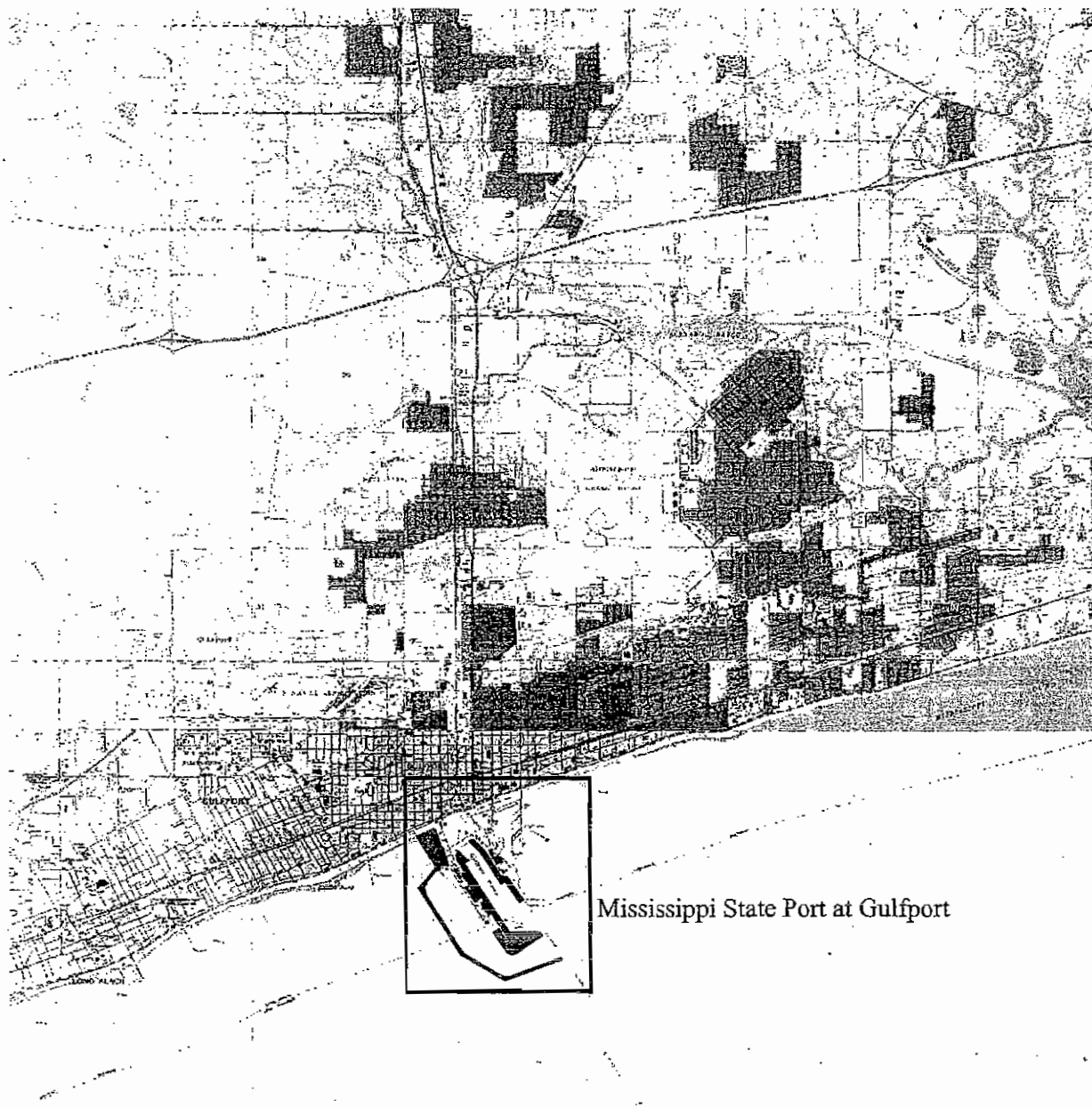

Mississippi State Port at Gulfport

Vicinity Map-Port Site  
10 Year Maintenance Dredging Plan  
Mississippi State Port at Gulfport  
Gulfport, Harrison County, Mississippi



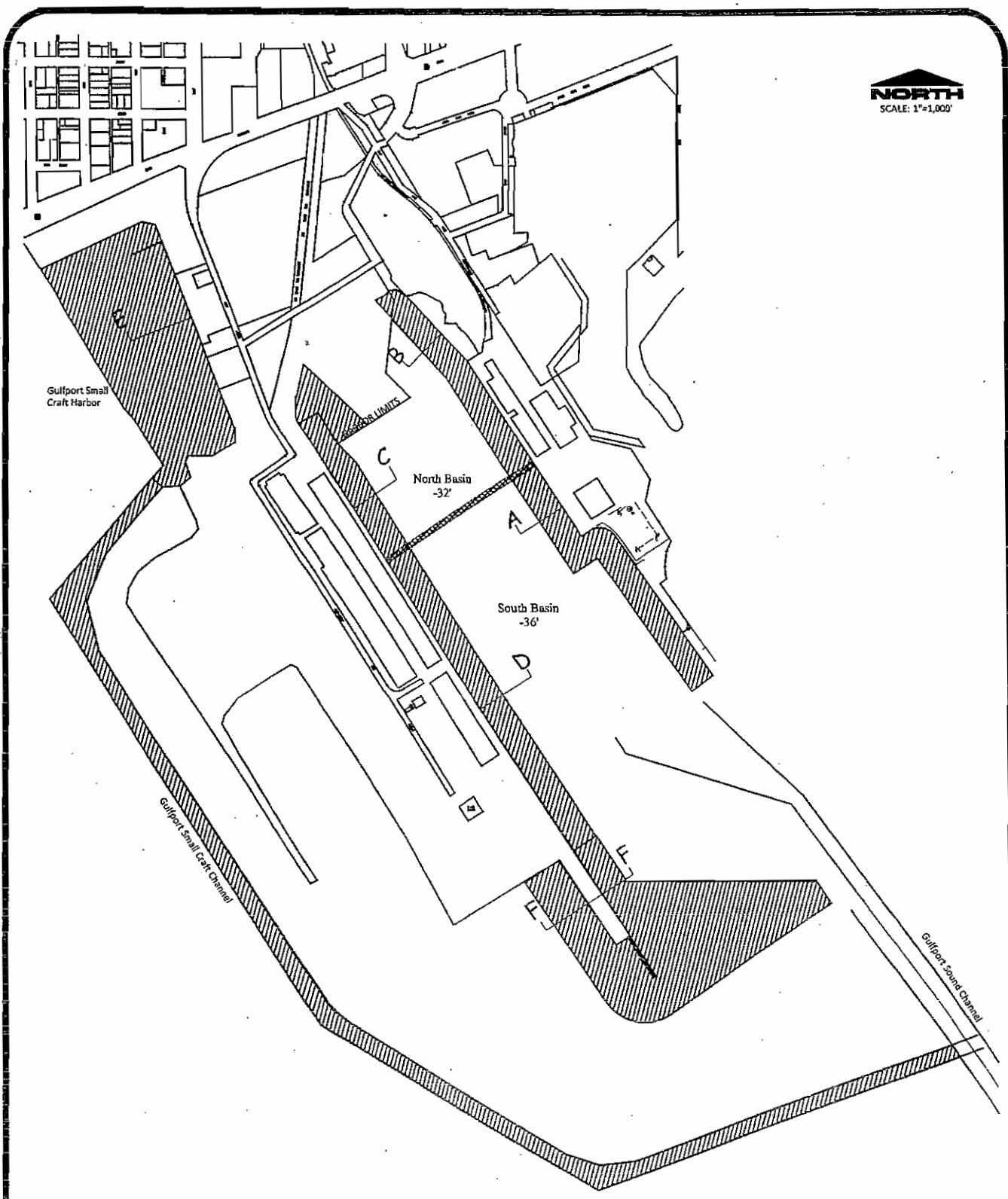



10 Year Maintenance Dredging Plan  
Mississippi State Port at Gulfport  
Gulfport, Harrison County, Mississippi



BMI Environmental Services, LLC  
*Environmental Consultants*

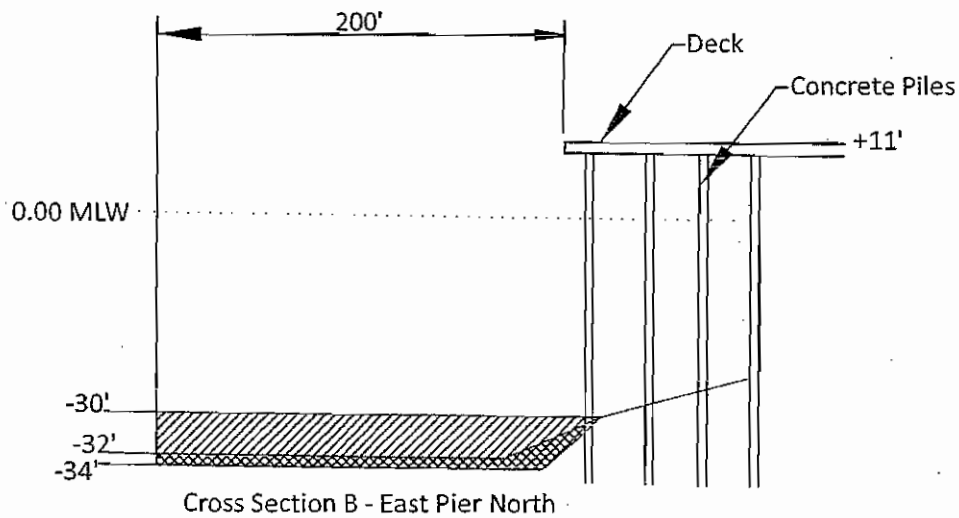
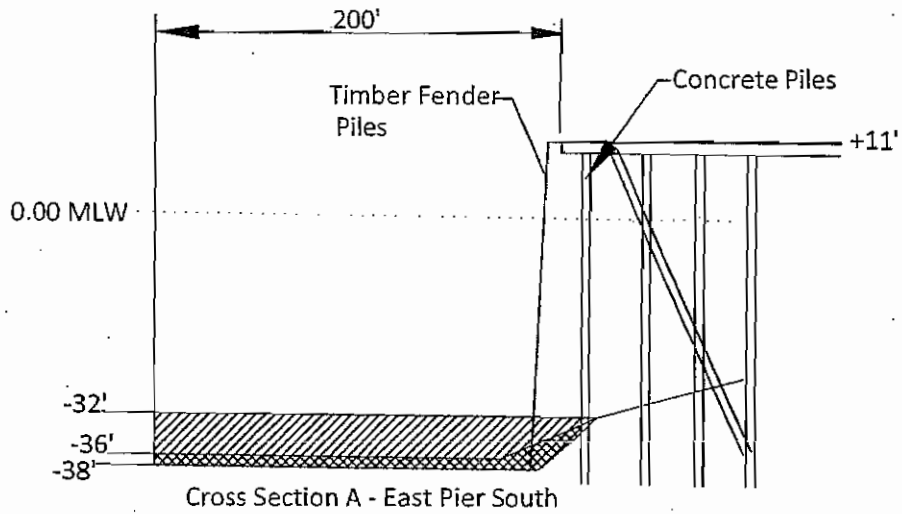

**APPROVED**

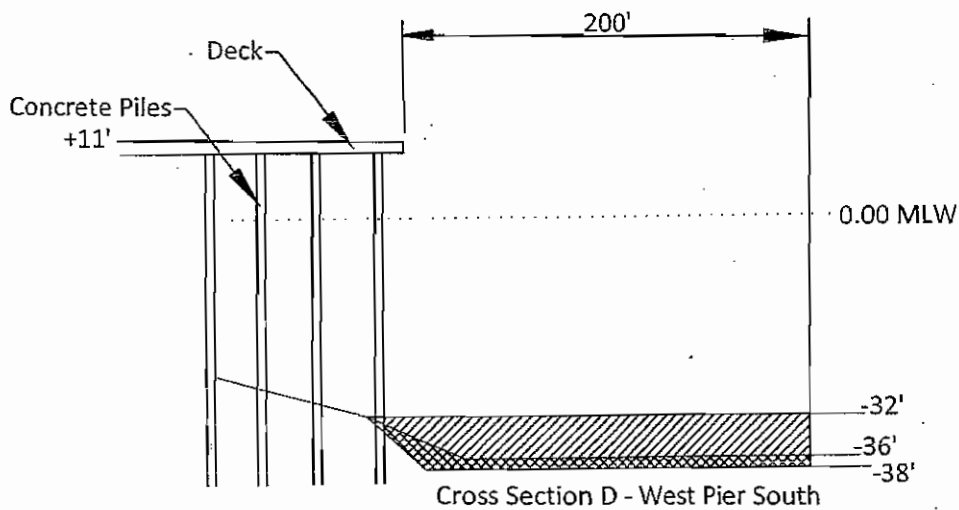
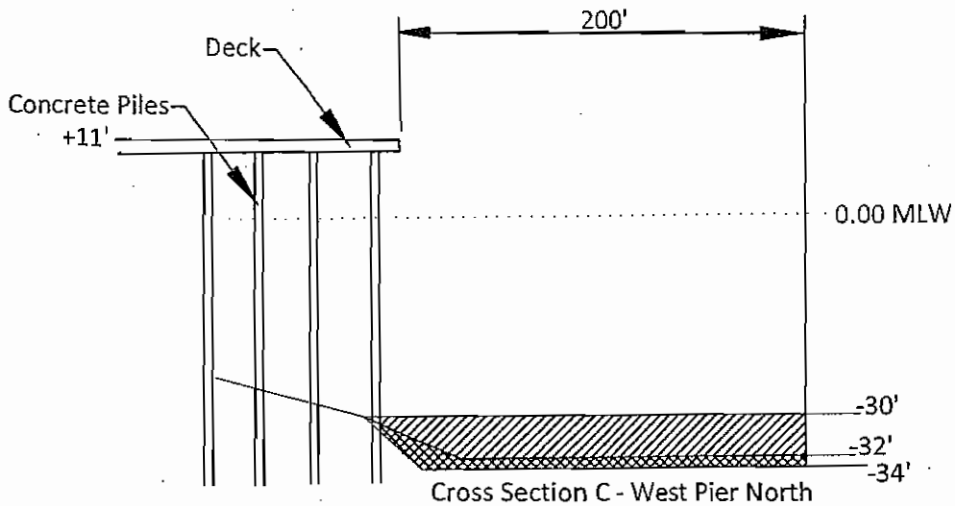

-  Material to be dredged
-  Allowable Overdepth

Cross Sections A & B - East Pier  
 10 Year Maintenance Dredging Plan  
 Mississippi State Port at Gulfport  
 Gulfport, Harrison County, Mississippi



 Material to be dredged  
 Allowable Overdepth

Cross Sections C & D - West Pier  
 10 Year Maintenance Dredging Plan  
 Mississippi State Port at Gulfport  
 Gulfport, Harrison County, Mississippi





BMI Environmental Services, LLC

Environmental Consultants

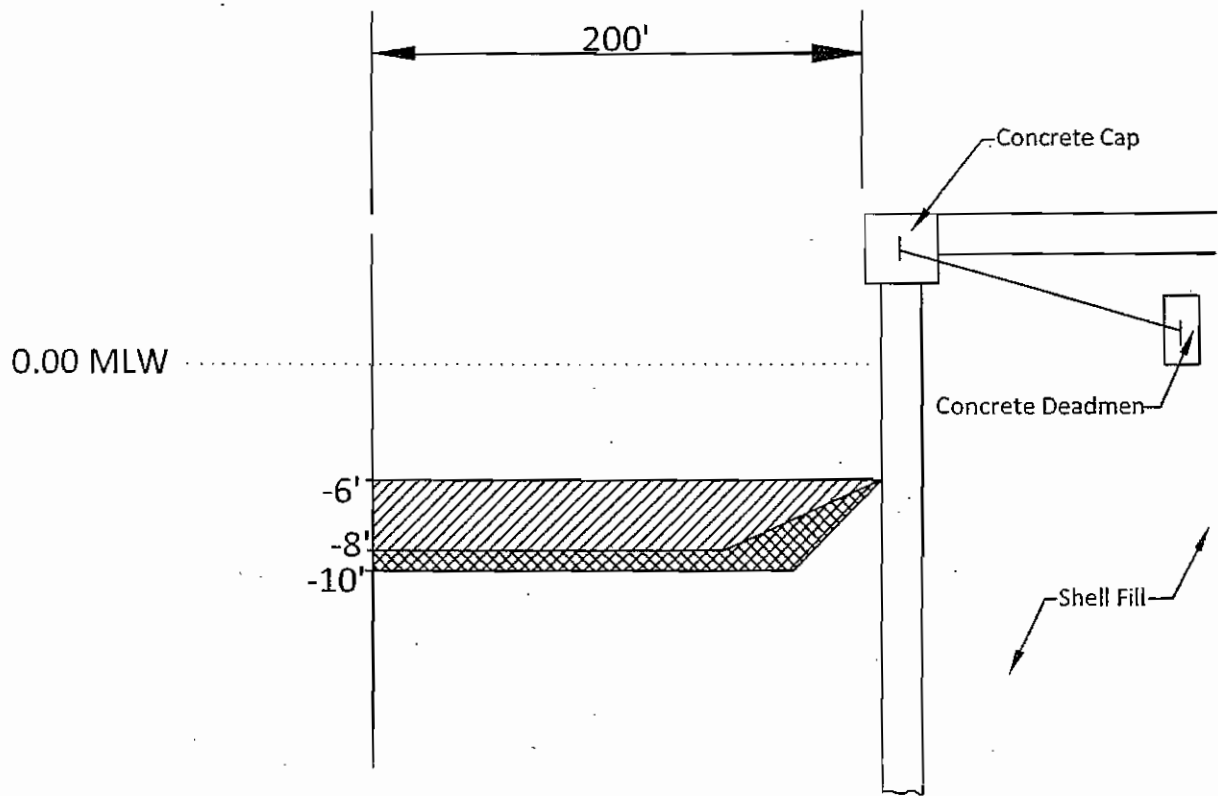
**APPROVED**



-  Material to be dredged
-  Allowable Overdepth

Cross Section E - Commercial Small Craft Harbor  
 10 Year Maintenance Dredging Plan  
 Mississippi State Port at Gulfport  
 Gulfport, Harrison County, Mississippi

**APPROVED**



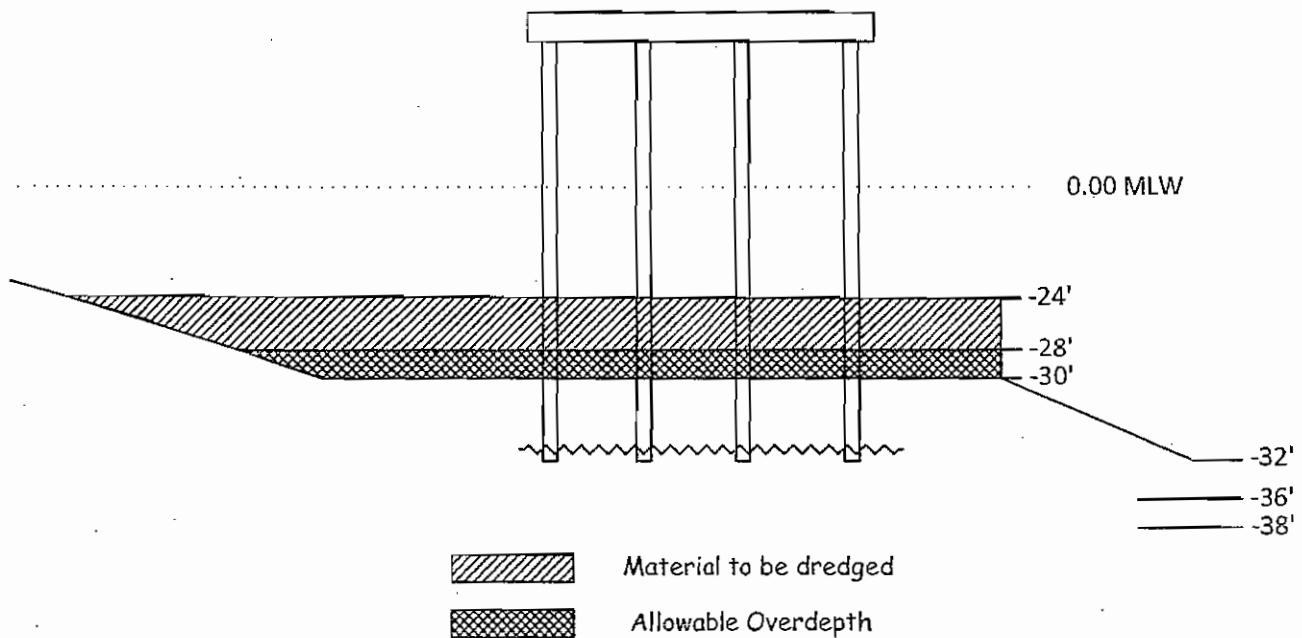

Cross Section F - West Pier 7  
 10 Year Maintenance Dredging Plan  
 Mississippi State Port at Gulfport  
 Gulfport, Harrison County, Mississippi



**NORTH**  
SCALE: 1"=4,000'

MISSISSIPPI STATE  
PORT AT GULFPORT

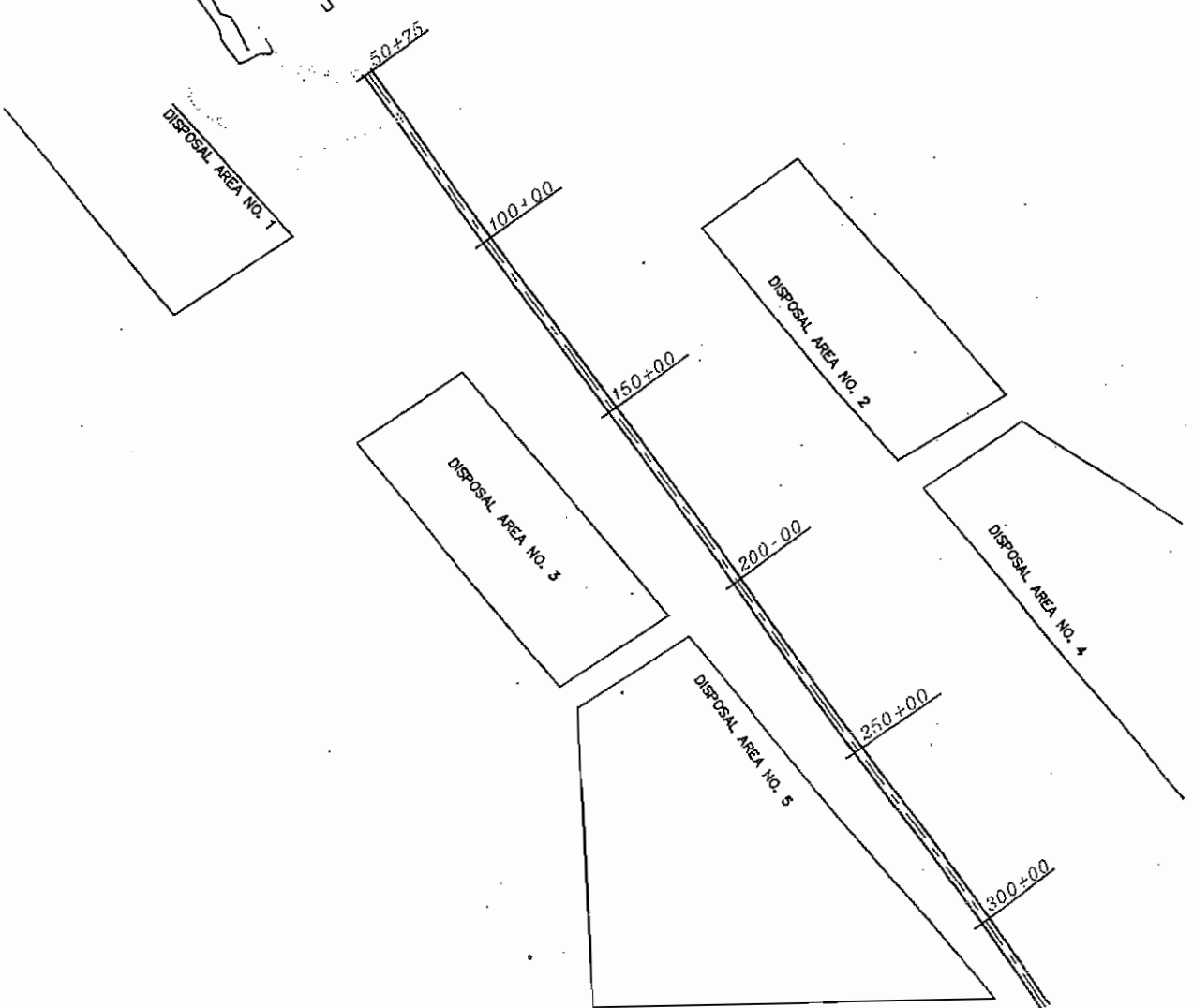

Open Water Disposal Areas - Mississippi Sound  
10 Year Maintenance Dredging Plan  
Mississippi State Port at Gulfport  
Gulfport, Harrison County, Mississippi

U:\03104\10yr\perm\map



**BMI Environmental Services, LLC**  
*Environmental Consultants*

March 2009

**APPROVED**

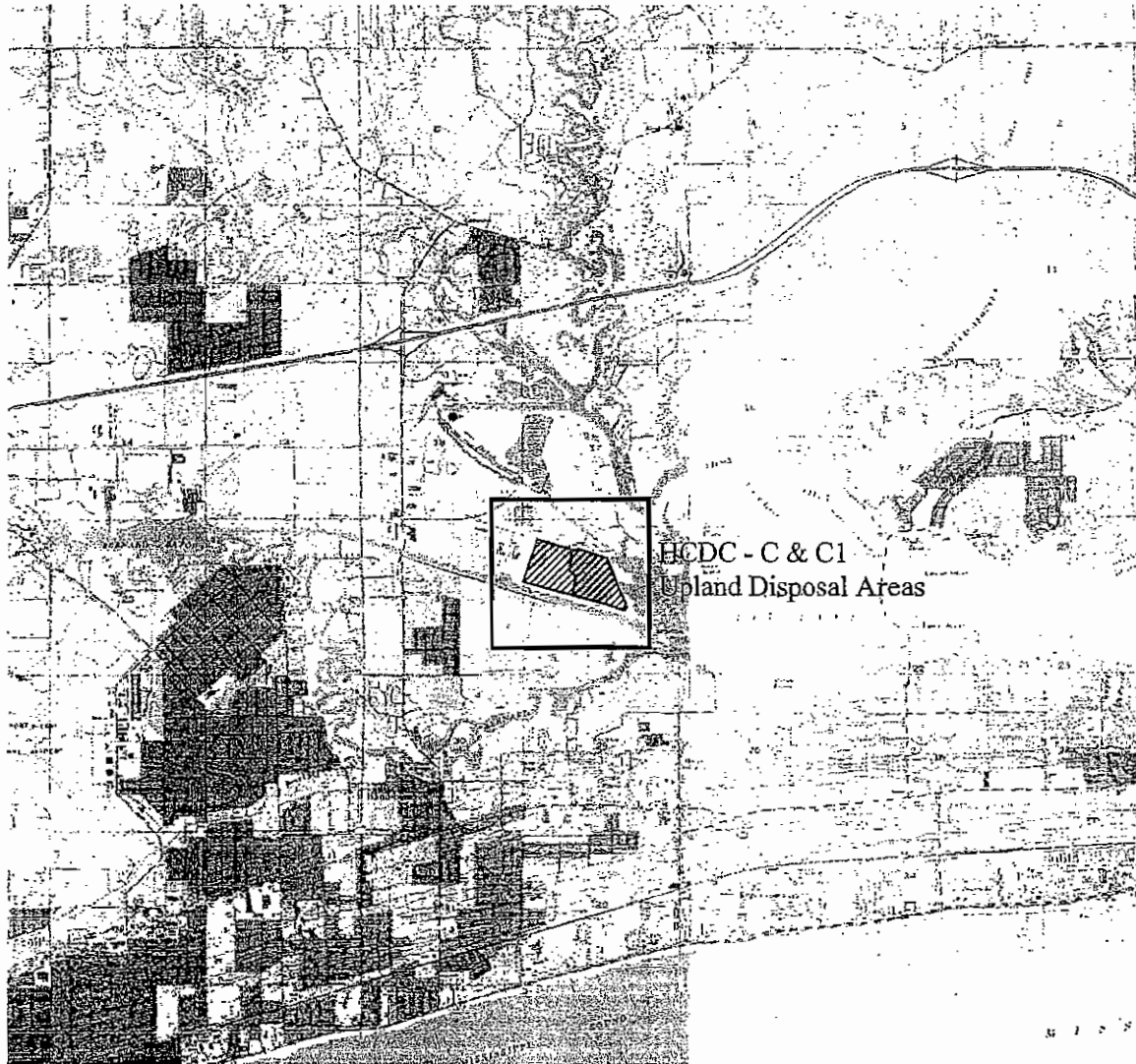

Vicinity Map-Uplands Disposal Areas  
10 Year Maintenance Dredging Plan  
Mississippi State Port at Gulfport  
Gulfport, Harrison County, Mississippi

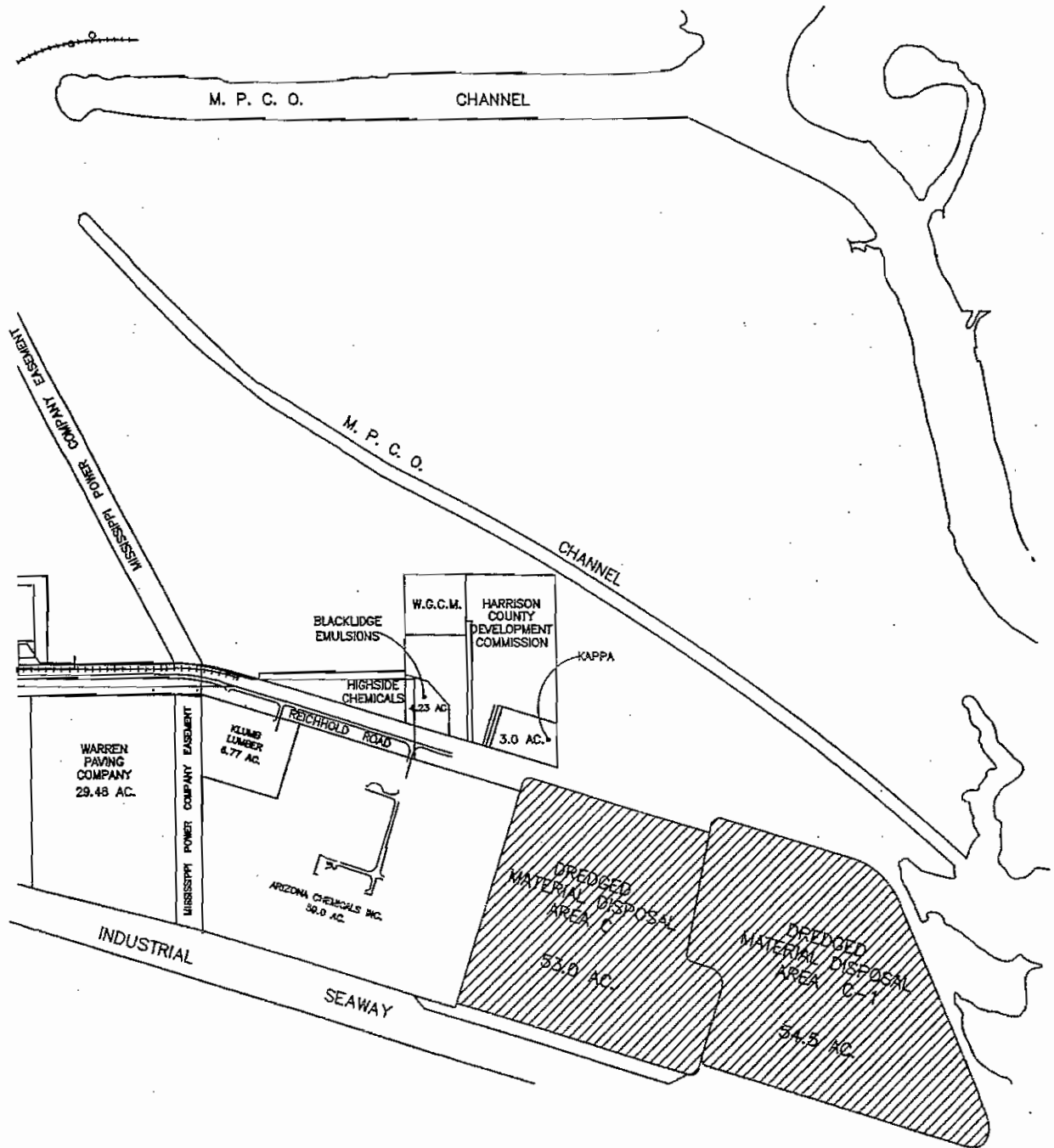

Upland Disposal Areas - HCDC Disposal Sites  
10 Year Maintenance Dredging Plan  
Mississippi State Port at Gulfport  
Gulfport, Harrison County, Mississippi



BMI Environmental Services, LLC  
Environmental Consultants

**APPROVED**



STATE OF MISSISSIPPI

Haley Barbour  
Governor

MISSISSIPPI DEPARTMENT OF MARINE RESOURCES

William W. Walker, Ph.D., Executive Director

June 17, 2009

Mississippi State Port  
P.O. Box 40  
Gulfport, MS 39501

RE: DMR-080020; State Port and Commercial Small Craft Harbor Dredging

Dear John Webb:

Please find enclosed a copy of the Certificate of Exclusion issued to you June 17, 2009.

Please execute this Certificate by signing both documents and returning the copy to the Department of Marine Resources.

If you have any questions regarding this correspondence, please contact James Davis with the Bureau of Wetlands Permitting at 228-523-4115 or [james.davis@dmr.ms.gov](mailto:james.davis@dmr.ms.gov).

Sincerely,

A handwritten signature in black ink, appearing to read "William W. Walker".

William W. Walker, Ph.D.  
Executive Director

WWW/jdd

Enclosures

cc: Mr. John B. McFadyen, USACE  
Mr. Robert Seyfarth, OPC  
Mr. Larry Lewis, BMI Environmental

**APPROVED**

Certification Number: DMR-080020  
Type: Exclusion  
Date: June 17, 2009

WHEREAS, application by: Mississippi State Port for compliance under the provisions of Chapter 27, Mississippi Code of 1972, as amended, to perform certain works affecting the coastal wetlands of the State of Mississippi on the MS Sound in Gulfport, Harrison County, Mississippi.

NOW THEREFORE, this certification authorizes the above named applicant hereinafter called permittee, to perform such works on the MS sound in Gulfport, MS in adherence to the following conditions contained herein:

1. An area 5,000 feet in length and 200 feet in width shall be dredged to a depth of 36 feet below mean low water as indicated on the attached diagram;
2. An area 5,000 feet in length and 200 feet in width shall be dredged to a depth of 38 feet below mean low water as indicated on the attached diagram;
3. An area 5,000 feet in length and 200 feet in width shall be dredged to a depth of 30 feet below mean low water as indicated on the attached diagram;
4. An area 3,680 feet in length and 1,000 feet in width shall be dredged to a depth of 10 feet below mean low water as indicated on the attached diagram;
5. An area 10,330 feet in length and 100 feet in width shall be dredged to a depth of 10 feet below mean low water as indicated on the attached diagram;
6. Approximately 200,000 cubic yards of dredge material shall be removed;
7. No sinks or sumps shall be created in the dredging process. Dredging depth is limited to that of the controlling navigational depth of the adjacent waters. A minimum 3:1 (horizontal: vertical) side slope shall be maintained in the dredge area;
8. A minimum distance of 10 feet shall be maintained between the dredge area and any wetlands;
9. Turbidity shall be minimized at the dredge site by methods such as using staked filter cloth, staged construction, and/or the use of turbidity screens around the immediate project site; and,

**APPROVED**

10. No dredging of wetlands, submerged aquatic vegetation or shellfish beds is authorized.

**This authorization is contingent on Water Quality Certification from the Mississippi Department of Environmental Quality.**

This certification conveys no title to land and water, and does not constitute authority for reclamation of coastal wetlands.

This certification authorizes no invasion of private property or rights in property.

This certification is issued on the further condition that the permittee notify the Department of Marine Resources in advance of any changes in the dimensions or procedures.

Granting of this certification does not relieve the permittee from requirements of a Permit from the U.S. Army Corps of Engineers nor from the necessity of compliance with all applicable state or local laws, ordinances and zoning or other regulations.

Work authorized by this certification must be completed on or before June 17, 2019

This certification shall become effective upon acceptance by the permittee and receipt of the executed copy.

Please execute this certification by signing both documents and returning the copy to the Department of Marine Resources.

The Department of Marine Resources has also coordinated a review of your project through the Coastal Program review procedures and determined that the project referenced above is consistent with the Mississippi Coastal Program, provided that you comply with the noted conditions and reviewing coastal program agencies do not disagree with said plans.

THE PERMITTEE BY ACCEPTANCE OF THIS CERTIFICATION AGREES TO ABIDE BY THE STIPULATIONS AND CONDITIONS CONTAINED HEREIN AND AS DESCRIBED BY THE PLANS AND SPECIFICATIONS SUBMITTED AS PART OF THE COMPLETED APPLICATION.

**APPROVED**

STATE OF MISSISSIPPI  
DEPARTMENT OF MARINE RESOURCES

BY:   
William W. Walker, Ph.D.  
Executive Director

Accepted this the 18<sup>th</sup> day of August, 20 09.

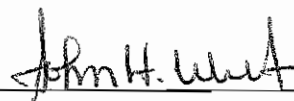
BY: 

WWW/jdd

Enclosures

cc: Mr. John B. McFadyen, USACE  
Mr. Robert Seyfarth, OPC  
Mr. Larry Lewis, BMI Environmental Services

**APPROVED**



# MISSISSIPPI



Department of Marine Resources

**NOTICE OF COMPLIANCE  
DMR- 080020EXCLUSION  
THIS NOTICE ACKNOWLEDGES THAT:**

**DATE: June 16, 2009**

**Mississippi State Port  
P.O. Box 40  
Gulfport, MS 39501**

**HAS, THROUGH APPLICATION TO THIS DEPARTMENT, DULY COMPLIED WITH THE MISSISSIPPI COASTAL WETLANDS PROTECTION LAW TO:**

1. An area 5,000 feet in length and 200 feet in width shall be dredged to a depth of 36 feet below mean low water as indicated on the attached diagram;
2. An area 5,000 feet in length and 200 feet in width shall be dredged to a depth of 38 feet below mean low water as indicated on the attached diagram;
3. An area 5,000 feet in length and 200 feet in width shall be dredged to a depth of 30 feet below mean low water as indicated on the attached diagram;
4. An area 3,680 feet in length and 1,000 feet in width shall be dredged to a depth of 10 feet below mean low water as indicated on the attached diagram;
5. An area 10,330 feet in length and 100 feet in width shall be dredged to a depth of 10 feet below mean low water as indicated on the attached diagram;
6. Approximately 200,000 cubic yards of dredge material shall be removed;
7. No sinks or sumps shall be created in the dredging process. Dredging depth is limited to that of the controlling navigational depth of the adjacent waters. A minimum 3:1 (horizontal: vertical) side slope shall be maintained in the dredge area;
8. A minimum distance of 10 feet shall be maintained between the dredge area and any wetlands;
9. Turbidity shall be minimized at the dredge site by methods such as using staked filter cloth, staged construction, and/or the use of turbidity screens around the immediate project site; and,
10. No dredging of wetlands, submerged aquatic vegetation or shellfish beds is authorized.

At the Mississippi State Port on the MS Sound in Gulfport, Harrison County, Mississippi.

**No construction debris or unauthorized fill material shall be allowed to enter coastal wetlands or waters.**

**FURTHERMORE, THIS PROJECT AS PROPOSED HAS BEEN FOUND TO BE CONSISTENT WITH ALL GUIDELINES FOR CONDUCT OF REGULATED ACTIVITIES IN COASTAL WETLANDS AS SET FORTH IN THE MISSISSIPPI COASTAL PROGRAM.**

  
Executive Director

POST THIS NOTICE CONSPICUOUSLY AT SITE OF WORK

**APPROVED**

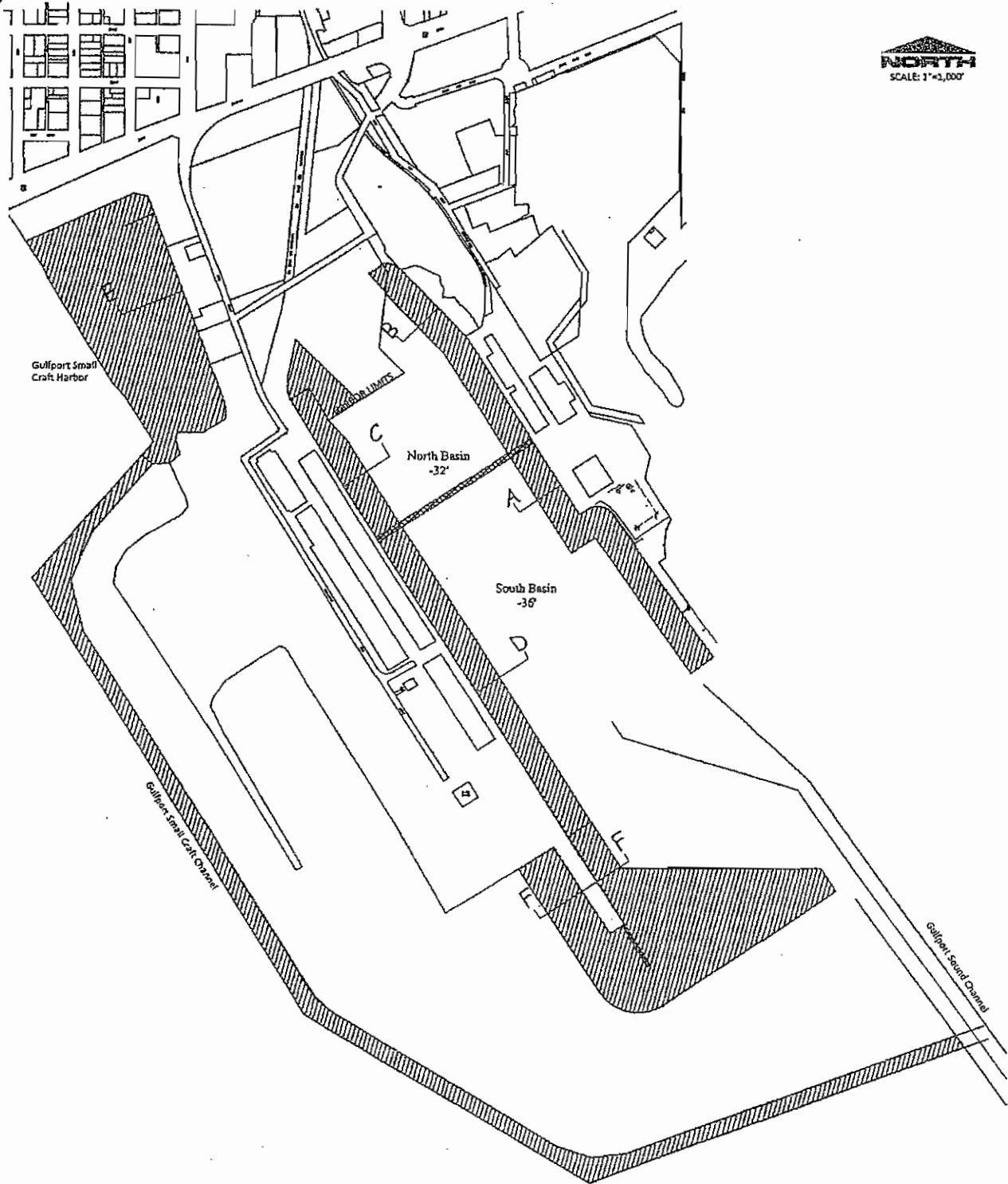

10 Year Maintenance Dredging Plan  
Mississippi State Port at Gulfport  
Gulfport, Harrison County, Mississippi



BMI Environmental Services, LLC

Environmental Consultants

**APPROVED**



STATE OF MISSISSIPPI  
HALEY BARBOUR  
GOVERNOR  
MISSISSIPPI DEPARTMENT OF ENVIRONMENTAL QUALITY  
TRUDY D. FISHER, EXECUTIVE DIRECTOR

August 3, 2009

Certified Mail No. 7005 3110 0003 6328 7811

Mr. John Webb  
Mississippi State Port Authority  
Post Office Box 40  
Gulfport, Mississippi 39501

Dear Mr. Webb:

Re: Mississippi State Port Authority  
of Gulfport  
Harrison County  
COE No. SAM20090433JBM  
WQC No. WQC2009019

Pursuant to Section 401 of the Federal Water Pollution Control Act (33 U. S. C. 1251, 1341), the Office of Pollution Control (OPC) issues this Certification, after public notice and opportunity for public hearing, Mississippi State Port Authority of Gulfport, an applicant for a Federal License or permit to conduct the following activity:

Mississippi State Port Authority of Gulfport: Proposed maintenance dredging of 200,000 cubic yards over a 10-year period from the Gulfport Harbor and the Gulfport Commercial Small Craft Harbor including the entrance channel. Material will be dredged by hydraulic and mechanical techniques. Hydraulically dredged material will be placed in the Federal Project Mississippi Sound open water disposal site, utilizing thin layer disposal techniques. Mechanically excavated material will be placed in the Harrison County Development Commission upland disposal areas C-1 and C-2. No wetlands or submerged aquatic vegetation will be impacted. This is a request to reauthorize work permitted by Department of the Army permit MS96-02521-U which expired in December 2006. [SAM20090433JBM, WQC2009019].

**APPROVED**

The Office of Pollution Control certifies that the above-described activity will be in compliance with the applicable provisions of Sections 301, 302, 303, 306, and 307 of the Federal Water Pollution Control Act and Section 49-17-29 of the Mississippi Code of 1972, if the applicant complies with the following conditions:

1. Basin and channel depths shall gradually increase toward open water and shall not exceed the controlling navigational depth. No "sumps" shall be created by proposed dredging.
2. Best management practices shall be used at all times during construction to minimize turbidity at both the dredge and spoil disposal sites. The disposal sites shall be constructed and maintained in a manner that minimizes the discharge of turbid waters into waters of the State.
3. Mechanically dredged material shall be transported in lined and covered trucks to an approved diked upland site for final disposal.
4. The mechanically excavated material shall be disposed in the contained upland disposal site and stabilized to prevent movement of sediment into adjacent drainage areas.
5. Turbidity outside the limits of a 750-foot mixing zone shall not exceed the ambient turbidity by more than 50 Nephelometric Turbidity Units.
6. No sewage, oil, refuse, or other pollutants shall be discharged into the watercourse.

The Office of Pollution Control also certifies that there are no limitations under Section 302 nor standards under Sections 306 and 307 of the Federal Water Pollution Control Act which are applicable to the applicant's above-described activity.

This certification is valid for the project as proposed. Any deviations without proper modifications and/or approvals may result in a violation of the 401 Water Quality Certification. If we can be of further assistance, please contact us.

Sincerely,

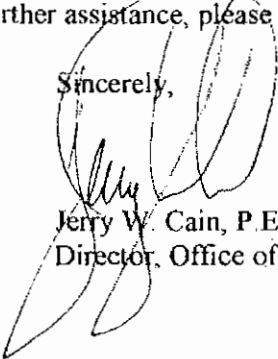

Jerry W. Cain, P.E., DEE  
Director, Office of Pollution Control

JWC:fw

4595 WQC20090001

**APPROVED**

---

Mr. John Webb  
Page 3 of 3  
August 3, 2009

cc: Mr. Larry Lewis, BMI Environmental, Inc.  
Mr. John B. McFadyen, U.S. Army Corps of Engineers, Mobile District  
Ms. Willa Brantley, Department of Marine Resources  
Mr. Duncan Powell, Environmental Protection Agency  
Ms. Janet Riddell, Office of Budget & Fund Management

4595 WQC20090001

---

**APPROVED**

MISSISSIPPI STATE PORT AUTHORITY  
PERMIT CONDITION REQUIREMENTS FOR DISPOSAL IN OPEN WATER SITES

"Thin Layer Dispersal" Process: The disposal (dispersal) process shall be operated in such a manner that the dredged material will settle out in the designated open water disposal areas (D/A) in thin layers. It is desired that the deposited material thickness not exceed a six (6) inch thick lift even if the deposited material settles immediately to the bottom after falling out of the dredge pipeline. However, due to the inaccuracies in the disposal process, material thickness up to a maximum of twelve (12) inches will be allowed. This specifically means that the existing bottom surfaces of disposal areas cannot be raised in elevation more than twelve (12) inches throughout the dredging operations. Any material deposited in excess of twelve (12) inches shall be removed by the Contractor at his own expense with no increase in contract price or time. The Contractor shall provide a positive means to disperse the dredged material deposit over enough D/A bottom surface area to accomplish this restriction. No dredge discharge will take place in a particular disposal area prior to the Contractor's submittal of the "before construction" survey (discussed elsewhere within this Specification), plotted in plan view. The "after construction" survey shall be made by the Contractor within one (1) week after dredge discharge into a particular disposal area ceases and that data plotted and submitted in plan view and in X-sections along with the "before construction" survey by the Contractor before final acceptance of the contract work in that area of channel is given. The Contractor shall prepare, operate and maintain the disposal areas in a manner to accomplish the contract required results. The Contractor shall also be aware that the amount of EXCESS DREDGING he performs will directly impact the outcome of the "Thin Layer Dispersal" process and the limitation discussed above. (EXCESS means greater than the required dredging plus allowable tolerances).

Disposal Area Surveys: The Contractor shall perform "before", "monthly" (or more frequent, if necessary), and "after" condition surveys along repeatable ranges covering the disposal site and adjacent bottoms within the limits specified herein all referenced to MLLW. The "before" and "after" condition surveys shall be taken within the five (5) day time period prior to commencement of disposal operations and within the five (5) days following completion of disposal operations at this disposal area. These surveys shall be oriented with ranges (cross sections) perpendicular to the channel centerline and ranges shall be spaced one-hundred (100) feet apart, and extended two hundred (200) feet beyond the disposal site limits. Soundings along each range shall be at least every 25 feet. The hydrographic surveys shall have a vertical accuracy of at least plus or minus 0.5 feet. The Contractor shall submit this data in "raw" form (fathometer charts, books, etc.) plotted form, and on a CD within five (5) working days after the surveys are completed. The data furnished to the Contracting Officer on CD's shall be in an "IBM compatible format, ASCII". The Contractor shall constantly monitor dredge disposal operations in order to comply with paragraph entitled DISPOSAL OF EXCAVATED MATERIALS.

Dredge (Excavation) Plant Instrumentation: All dredge (excavation) plant utilized shall be instrumented to monitor where excavation takes place and describe the excavation sequence as specified herein. The data produced by this instrumentation will be collected by automated (computer-digitized) means and stored on a CD in an "IBM P.C. compatible format, DOS Operating System". Each CD can be used to its maximum storage space up to one weeks data, if capable. The original disks will be submitted to the Government at the end of the project. Also each week's data collection will be presented in a graphic form, i.e., plotted, identified and indexed to show the work area (excavation and disposal as appropriate) of each day distinctly. This can be done with more than one day's data on one graph with different colors for the different days or on individual graphs for each individual day. All horizontal positions referred to below shall be referenced to the Mississippi State Plane Coordinate System.

If the dredge is a hydraulic pipeline dredge, the following elements shall be monitored, as a minimum:

- (a) Dredge I.D. designation.
- (b) Dredge cutterhead location in the X, Y and Z directions at least every minute interval, all tied to real time of day and date.
- (c) If dredge material discharge is in a location other than that designated, X and Y directions of discharge point at least every minute interval, all tied to real time of day and date

If the dredge is a mechanical-type (bucket) dredge the following elements shall be monitored, as a minimum:

- (a) Dredge I.D. designation.
- (b) Dredge bucket location in the X, Y and Z directions, at both the bucket grab closing point and the bucket release or opening point over the transport vessel, all tied to real time of day and date.
- (c) Trip Identification.
- (d) Tow Vessel I.D. designation and its position every five minute interval sailing to/from the disposal area; position at least every minute interval during the travel immediately approaching the Disposal Area boundary, through the Disposal Area, and during the travel immediately after exiting the Disposal Area boundary, all tied to real time of day and date.
- (e) Transport Vessel I.D. designation.
- (f) Name of captain of vessel.
- (g) Number of transport vessels used, and distance from tow vessel.
- (h) Transport vessel draft, on same intervals as (d) above, all tied to real time of day and date.

If any other type dredge is used, these same basic elements will be required to be monitored to specifically document where the excavation takes place, how the excavated material moves to the Disposal Area and proof that the excavated material was properly deposited into the proper Disposal Area.

**APPROVED**

If a dragging operation is used in conjunction with a dredge the following elements will be monitored, as a minimum:

- a. I.D. designation.
- b. Drag device's horizontal location (X and Y), while performing dragging operations.

The Dredge Plant Instrumentation is a part of the dredge plant and must be functional at all times. If failure of any part thereof occurs the Contractor will be expected to repair the failed part within the next 24 hours restoring full operations. If failure to repair does not occur in that period, the particular plant affected will be considered non-responsive to the contract requirement and will either be replaced or a redundancy part added to render the plant fully operational to include the monitored data, all at no additional increased price or time to the contract.

**APPROVED**



**Endangered Species Act - Section 7 Consultation  
Biological Opinion**

**Action Agency:** U.S. Army Corps of Engineers, Mobile District (MDCOE)  
**Activity:** Maintenance dredging of Gulfport Harbor Navigation Project  
(Consultation Number F/SER/2007/02307)  
**Consulting Agency:** National Oceanic and Atmospheric Administration, National  
Marine Fisheries Service (NMFS), Southeast Regional Office,  
Protected Resources Division, St. Petersburg, Florida

**Approved By:**



Roy E. Crabtree, Ph.D., Regional Administrator  
NMFS, Southeast Regional Office  
St. Petersburg, Florida

**Date Issued:**

7/9/07

---

**Table of Contents**

1	CONSULTATION HISTORY.....	4
2	DESCRIPTION OF THE PROPOSED ACTION AND ACTION AREA.....	4
3	STATUS OF LISTED SPECIES AND CRITICAL HABITAT.....	5
4	ENVIRONMENTAL BASELINE.....	9
5	EFFECTS OF THE ACTION ON GULF STURGEON CRITICAL HABITAT ....	13
6	CUMULATIVE EFFECTS.....	17
7	CONCLUSION .....	17
8	INCIDENTAL TAKE STATEMENT.....	17
9	CONSERVATION RECOMMENDATIONS .....	17
10	REINITIATION OF CONSULTATION.....	18
11	LITERATURE CITED .....	18

APPROVED

## Background

Section 7(a)(2) of the Endangered Species Act (ESA) of 1973, as amended (16 U.S.C. § 1531 *et seq.*), requires that each federal agency shall ensure that any action authorized, funded, or carried out by such agency is not likely to jeopardize the continued existence of any endangered or threatened species or result in the destruction or adverse modification of critical habitat of such species; section 7(a)(2) requires federal agencies to consult with the appropriate Secretary on any such action. NMFS and the U.S. Fish and Wildlife Service (USFWS) share responsibilities for administering the ESA.

Consultation is required when a federal action agency determines that a proposed action “may affect” listed species or designated critical habitat. Consultation is concluded after NMFS determines that the action is not likely to adversely affect listed species or critical habitat or issues a biological opinion (opinion) that identifies whether a proposed action is likely to jeopardize the continued existence of a listed species, or destroy or adversely modify critical habitat. The opinion states the amount or extent of incidental take of the listed species that may occur, develops measures (i.e., reasonable and prudent measures - RPMs) to reduce the effect of take, and recommends conservation measures to further conserve the species. Notably, no incidental destruction or adverse modification of critical habitat can be authorized, and thus there are no reasonable and prudent measures, only reasonable and prudent alternatives that must avoid destruction or adverse modification.

This document represents NMFS’ opinion based on our review of impacts associated with the dredging and disposal of materials associated with maintaining the Gulfport Harbor Navigation Project in Mississippi Sound, Harrison County, Mississippi, over a period of 10 years.

The MDCOE will perform the proposed action. This opinion analyzes project effects on Gulf sturgeon critical habitat in accordance with section 7 of the ESA, and is based on project information provided by MDCOE and other sources of information including the published literature cited herein.

## BIOLOGICAL OPINION

### 1 CONSULTATION HISTORY

The routine operations and maintenance dredging of the Gulfport Harbor Navigation Project was previously coordinated with NMFS, resulting in a June 24, 2004, biological opinion. However, this opinion was limited to the effects of work conducted between June and September 2004. As a result of Hurricane Katrina, emergency coordination was conducted with NMFS via e-mail on October 6, 2005.

To maintain sufficient channel depths, the project must be dredged every 12-18 months due to shoaling. Therefore, the MDCOE provided NMFS a biological assessment for work to be conducted over a 10-year period on January 18, 2007. This submission determined that the proposed action was "not likely to result in the destruction or adverse modification of critical habitat," and requested a formal ESA section 7 consultation.

The MDCOE amended the consultation submission on March 27, 2007, via e-mail, and requested the opinion evaluate the effects of the action over a 10-year period.

### 2 DESCRIPTION OF THE PROPOSED ACTION AND ACTION AREA

#### 2.1 Proposed action

The proposed Gulfport Harbor Navigation Project action includes the following work over a 10-year period:

1. Maintenance dredging of: a Gulf entrance channel (Ship Island Pass) 38 feet deep, 300 feet wide, and approximately 8 miles long across Ship Island Bar; a channel 36 feet deep, 220 feet wide, and approximately 12 miles long through Mississippi Sound; and a stepped anchorage basin at Gulfport Harbor 32-36 feet deep, 1,120 feet wide, and 2,450 feet long.
2. Maintenance dredging of: a commercial small boat harbor, about 26 acres in area, and an entrance channel 100 feet wide at a depth of 8 feet.

Dredging will be performed by hydraulic and/or hopper dredge and with a tolerance of up to two feet advanced maintenance and up to two feet of overdepth dredging. Maintenance dredging is currently required every 12-18 months for the Gulf entrance and Ship Island Pass channel segments, every 18 months for the Mississippi Sound channel segment, and every 18-24 months for the anchorage area. For each maintenance dredging cycle during the ten-year period, dredged material will be disposed as follows:

1. Approximately 3.9 million cubic yards of dredged material from the Mississippi Sound channel segment and anchorage area will be placed in thin-layer disposal sites west of the channel, no more than 12 inches in thickness;
2. Approximately 750,000 cubic yards of dredged material from the Ship Island Pass channel segment will be placed in the littoral zone disposal site southeast of Cat Island in

Mississippi Sound or at the two Ocean Dredged Material Disposal Sites (ODMDS) in the Gulf of Mexico; and

3. Approximately 400,000 cubic yards of dredged material from the Gulf entrance channel segment will be placed in the littoral zone disposal site southeast of Cat Island in Mississippi Sound or at the two ODMDS in the Gulf of Mexico.

## 2.2 Action area

50 CFR 404.02 defines action area as "all areas to be affected directly or indirectly by the federal action and not merely the immediate area involved in the action." The action area is the Gulfport Channel and anchorage basin, Mississippi Sound, Mississippi, and entrance channel in the Gulf of Mexico.

## 3 STATUS OF LISTED SPECIES AND CRITICAL HABITAT

The following endangered (E) and threatened (T) species under the jurisdiction of NMFS may occur in or near the action area:

<u>Common Name</u>	<u>Scientific Name</u>	<u>Status</u>
<b>Sea Turtles</b>		
Loggerhead sea turtle	<i>Caretta caretta</i>	T
Hawksbill sea turtle	<i>Eretmochelys imbricata</i>	E
Leatherback sea turtle	<i>Dermochelys coriacea</i>	E
Kemp's ridley sea turtle	<i>Lepidochelys kempii</i>	E
Green sea turtle	<i>Chelonia mydas</i> <sup>1</sup>	E/T
<b>Fish</b>		
Gulf sturgeon	<i>Acipenser oxyrinchus desotoi</i>	T
Smalltooth sawfish	<i>Pristis pectinata</i>	E

### Critical Habitat

Within the Gulf of Mexico, NMFS has only designated critical habitat for Gulf sturgeon.

### 3.1 Species not likely to be affected

Gulfport Harbor channels are identified in NMFS' revised regional biological opinion (GMRBO; NMFS 2007) to the COE's Gulf of Mexico districts on hopper dredging of navigation channels and borrow areas. The GMRBO analyzes and accounts for the effects of maintenance dredging, as well as channel widening and deepening "to previously authorized dimensions," on listed species. Therefore, listed sea turtle and fish species are not considered further in this opinion;

---

<sup>1</sup> Green turtles in U.S. waters are listed as threatened except for the Florida breeding population, which is listed as endangered. Due to the inability to distinguish between these populations away from the nesting beach, green turtles are considered endangered wherever they occur in U.S. waters.

rather, the GMRBO addresses effects to listed species; any takes of sea turtles or Gulf sturgeon will be counted against the incidental take statement (ITS) of that opinion, and the RPMs and terms and conditions of that ITS are applicable to this action.

### 3.2 Critical habitat likely to be affected

Gulf sturgeon critical habitat was jointly designated by NMFS and USFWS on April 18, 2003 (50 CFR 226.214). Critical habitat is defined in section 3(5)(A) of the ESA as (i) the specific areas within the geographic area occupied by a species, at the time it is listed in accordance with the Act, on which are found those physical or biological features (I) essential to the conservation of the species and (II) that may require special management considerations or protection; and (ii) specific areas outside the geographic area occupied by a species at the time it is listed, upon a determination that such areas are essential for the conservation of the species. "Conservation" is defined in section 3(3) of the ESA as the use of all methods and procedures that are necessary to bring any endangered or threatened species to the point at which listing under the ESA is no longer necessary.

Gulf sturgeon critical habitat includes areas within the major river systems that support the seven currently reproducing sub-populations (USFWS et al. 1995) and associated estuarine and marine habitats. Gulf sturgeon use the rivers for spawning, larval and juvenile feeding, adult resting and staging, and to move between the areas that support these components. Gulf sturgeon use the lower riverine, estuarine, and marine environments during winter months primarily for feeding and, more rarely, for inter-river migrations. Estuaries and bays adjacent to the riverine units provide unobstructed passage of sturgeon from feeding areas to spawning grounds.

Fourteen areas (units) are designated as Gulf sturgeon critical habitat. Critical habitat units encompass approximately 2,783 river kilometers (km) and 6,042 km<sup>2</sup> of estuarine and marine habitats and include portions of the following Gulf of Mexico rivers, tributaries, estuarine and marine areas:

- Unit 1. Pearl and Bogue Chitto Rivers in Louisiana and Mississippi;
- Unit 2. Pascagoula, Leaf, Bowie, Big Black Creek, and Chickasawhay Rivers in Mississippi;
- Unit 3. Escambia, Conecuh, and Sepulga Rivers in Alabama and Florida;
- Unit 4. Yellow, Blackwater, and Shoal Rivers in Alabama and Florida;
- Unit 5. Choctawhatchee and Pea Rivers in Florida and Alabama;
- Unit 6. Apalachicola and Brothers Rivers in Florida;
- Unit 7. Suwannee and Withlacoochee River in Florida;
- Unit 8. Lake Pontchartrain (east of causeway), Lake Catherine, Little Lake, the Rigolets, Lake Borgne, Pascagoula Bay, and Mississippi Sound systems in Louisiana and Mississippi, and sections of the state waters within the Gulf of Mexico;
- Unit 9. Pensacola Bay system in Florida;
- Unit 10. Santa Rosa Sound in Florida;
- Unit 11. Nearshore Gulf of Mexico in Florida;
- Unit 12. Choctawhatchee Bay system in Florida;
- Unit 13. Apalachicola Bay system in Florida; and

Unit 14. Suwannee Sound in Florida.

Critical habitat determinations focus on those physical and biological features (primary constituent elements; PCEs) that are essential to the conservation of the species (50 CFR 424.12). Federal agencies must ensure that their activities are not likely to result in the destruction or adverse modification of the PCEs within defined critical habitats. Therefore, proposed actions that may impact designated critical habitat require an analysis of potential impacts to each PCE.

PCEs identified as essential for the conservation of the Gulf sturgeon consist of:

1. Abundant food items, such as detritus, aquatic insects, worms, and/or molluscs, within riverine habitats for larval and juvenile life stages; and abundant prey items, such as amphipods, lancelets, polychaetes, gastropods, ghost shrimp, isopods, molluscs and/or crustaceans, within estuarine and marine habitats and substrates for sub-adult and adult life stages;
2. Riverine spawning sites with substrates suitable for egg deposition and development, such as limestone outcrops and cut limestone banks, bedrock, large gravel or cobble beds, marl, soapstone, or hard clay;
3. Riverine aggregation areas, also referred to as resting, holding, and staging areas, used by adult, sub-adult, and/or juveniles, generally, but not always, located in holes below normal riverbed depths, believed necessary for minimizing energy expenditures during fresh water residency and possibly for osmoregulatory functions;
4. A flow regime (i.e., the magnitude, frequency, duration, seasonality, and rate-of-change of fresh water discharge over time) necessary for normal behavior, growth, and survival of all life stages in the riverine environment, including migration, breeding site selection, courtship, egg fertilization, resting, and staging, and for maintaining spawning sites in suitable condition for egg attachment, egg sheltering, resting, and larval staging;
5. Water quality, including temperature, salinity, pH, hardness, turbidity, oxygen content, and other chemical characteristics, necessary for normal behavior, growth, and viability of all life stages;
6. Sediment quality, including texture and other chemical characteristics, necessary for normal behavior, growth, and viability of all life stages; and
7. Safe and unobstructed migratory pathways necessary for passage within and between riverine, estuarine, and marine habitats (e.g., an unobstructed river or a dammed river that still allows for passage).

As stated in the final rule designating Gulf sturgeon critical habitat, the following activities, among others, when authorized, funded or carried out by a federal agency, may destroy or adversely modify critical habitat:

1. Actions that would appreciably reduce the abundance of riverine prey for larval and juvenile sturgeon, or of estuarine and marine prey for juvenile and adult Gulf sturgeon, within a designated critical habitat unit, such as dredging; dredged

- material disposal; channelization; in-stream mining; and land uses that cause excessive turbidity or sedimentation;
2. Actions that would appreciably reduce the suitability of Gulf sturgeon spawning sites for egg deposition and development within a designated critical habitat unit, such as impoundment; hard-bottom removal for navigation channel deepening; dredged material disposal; in-stream mining; and land uses that cause excessive sedimentation;
  3. Actions that would appreciably reduce the suitability of Gulf sturgeon riverine aggregation areas, also referred to as resting, holding, and staging areas, used by adult, sub-adult, and/or juveniles, believed necessary for minimizing energy expenditures and possibly for osmoregulatory functions, such as dredged material disposal upstream or directly within such areas; and other land uses that cause excessive sedimentation;
  4. Actions that would alter the flow regime (the magnitude, frequency, duration, seasonality, and rate-of-change of fresh water discharge over time) of a riverine critical habitat unit such that it is appreciably impaired for the purposes of Gulf sturgeon migration, resting, staging, breeding site selection, courtship, egg fertilization, egg deposition, and egg development, such as impoundment; water diversion; and dam operations;
  5. Actions that would alter water quality within a designated critical habitat unit, including temperature, salinity, pH, hardness, turbidity, oxygen content, and other chemical characteristics, such that it is appreciably impaired for normal Gulf sturgeon behavior, reproduction, growth, or viability, such as dredging; dredged material disposal; channelization; impoundment; in-stream mining; water diversion; dam operations; land uses that cause excessive turbidity; and release of chemicals, biological pollutants, or heated effluents into surface water or connected groundwater via point sources or dispersed non-point sources;
  6. Actions that would alter sediment quality within a designated critical habitat unit such that it is appreciably impaired for normal Gulf sturgeon behavior, reproduction, growth, or viability, such as dredged material disposal; channelization; impoundment; in-stream mining; land uses that cause excessive sedimentation; and release of chemical or biological pollutants that accumulate in sediments; and
  7. Actions that would obstruct migratory pathways within and between adjacent riverine, estuarine, and marine critical habitat units, such as dams, dredging, point-source-pollutant discharges, and other physical or chemical alterations of channels and passes that restrict Gulf sturgeon movement (68 FR 13399).

The GMRBO requires separate consultation on dredging or disposal of dredged materials in Gulf sturgeon critical habitat. As dredging and disposal of dredged material will modify habitat, NMFS believes that designated critical habitat for Gulf sturgeon may be affected by the project. However, since channels encompassed by the proposed Gulfport Harbor Navigation Project are considered major shipping channels and are identified on standard navigation charts, they are excluded from, and not considered as part of, Gulf sturgeon critical habitat, as specified by 50 CFR §226.214(h)(2). Therefore, this opinion will only focus on the effects of the disposal of

dredged material within Mississippi Sound, which is Gulf sturgeon critical habitat (i.e., critical habitat Unit 8).

Within Unit 8, PCEs potentially affected by the proposed project include water quality, migratory pathways, sediment quality, and prey abundance. However, with the exception of prey abundance, NMFS expects the effects of the proposed action will not affect or will only have insignificant effects on these PCEs. Water quality impacts from sediment disturbance as a result of disposal are expected to be temporary and minimal, with suspended particles settling out within a short time frame without measurable effects on water quality. No changes in temperature, salinity, pH, hardness, oxygen content, and other chemical characteristics are expected. NMFS only expects insignificant effects to Gulf sturgeon critical habitat as a result of water quality impacts related to this project.

Within critical habitat Unit 8, sub-adult and adult Gulf sturgeon move from the rivers through estuarine and marine areas to feeding areas. Unit 8 is known to support migratory pathways for Gulf sturgeon from two sub-populations (Pascagoula and Pearl Rivers), as groups of individuals from these sub-populations have been located by telemetry on numerous occasions throughout the unit (Reynolds 1993; Rogillio et al. 2001; Ross et al. 2001a). However, NMFS is not aware of any data describing Gulf sturgeon presence or absence within the Gulfport Channel, or use of the channel itself as a migration route. However, Gulf sturgeon likely swim through the project area during their intermittent inter-riverine movements. Therefore, NMFS concludes from the absence of localized relocation data coupled with the nature of the action (i.e., thin-layer disposal with a minimum depth of -4 ft mean low water), that the proposed action over a 10-year period would have no effect on the ability of critical habitat Unit 8 to provide a migratory pathway for Gulf sturgeon.

Substrate modification can impact prey availability and abundance; potential project impacts relative to Gulf sturgeon prey are presented in the next section. The proposed action will directly impact the benthos by the placement of dredged material into the disposal areas. The composition of the dredged materials removed from the channel is expected to be the same as that remaining; sediment quality and texture of the spoil have been described by MDCOE as identical to the existing conditions at all disposal sites. Furthermore, the results of the National Demonstration Project that occurred in the project area (MDCOE 1999) report that: 1) The repetitive long-term use of thin-layer disposal generally has no long-lasting effect on sediment texture in the area, 2) benthic biotic community composition of sites utilized in the study for disposal were similar to those that did not experience thin-layer placement, and 3) site variations were within the natural variation of the system and not a result of the thin-layer placement, with the exception of the first three months immediately following the disposal. NMFS also considered the potential of contamination in the project area; a contaminant sink would impact Gulf sturgeon health. The sediment being removed from the anchorage and the channel is not known to contain any contaminants (J. Jacobson, MDCOE, pers. comm., June 16, 2004). Therefore, NMFS concludes the proposed action over a 10-year period will have only insignificant effects on sediment quality of critical habitat Unit 8.

#### 4 ENVIRONMENTAL BASELINE



This section contains a description of the effects of past and ongoing human activities leading to the current status of the species, their habitat, and the ecosystem, within the action area. The environmental baseline is a snapshot of the factors affecting the species and includes federal, state, tribal, local, and private actions already affecting the species, or that will occur contemporaneously with the consultation in progress. Unrelated, future federal actions affecting the same species that have completed formal or informal consultation are also part of the environmental baseline, as are implemented and ongoing federal and other actions within the action area that may benefit listed species.

#### 4.1 Status of critical habitat within the action area

Of the fourteen units designated as Gulf sturgeon critical habitat, only Unit 8 will be impacted by the maintenance of Gulfport Channel (i.e., dredging and disposal) project. Unit 8 encompasses Lake Pontchartrain east of the Lake Pontchartrain Causeway, Little Lake, The Rigolets, Lake St. Catherine, and Lake Borgne, including Heron Bay, and the Mississippi Sound. Critical habitat follows the shorelines around the perimeters of each included lake. The Mississippi Sound includes adjacent open bays including Pascagoula Bay, Point aux Chenes Bay, Grand Bay, Sandy Bay, and barrier island passes, including Ship Island Pass, Dog Keys Pass, Horn Island Pass, and Petit Bois Pass. Unit 8 critical habitat within Mississippi Sound is defined by the following boundaries:

The northern boundary of the Mississippi Sound is the shoreline of the mainland between Heron Bay Point, Mississippi, and Point aux Pins, Alabama. Critical habitat excludes St. Louis Bay, north of the railroad bridge across its mouth; Biloxi Bay, north of the U.S. Highway 90 bridge; and Back Bay of Biloxi. The southern boundary follows along the broken shoreline of Lake Borgne created by low swamp islands from Malheureux Point to Isle au Pitre. From the northeast point of Isle au Pitre, the boundary continues in a straight north-northeast line to the point one nautical mile (nm) seaward of the westernmost extremity of Cat Island (30°13'N, 89°10'W). The southern boundary continues one nm offshore of the barrier islands and offshore of the 72 COLREGS lines at barrier island passes [defined at 33 CFR 80.815 (c), (d) and (e)] to the eastern boundary. Between Cat Island and Ship Island there is no 72 COLREGS line. NMFS has therefore defined that section of the unit southern boundary as one nm offshore of a straight line drawn from the southern tip of Cat Island to the western tip of Ship Island. The eastern boundary is the line of longitude 88°18.8'W from its intersection with the shore (Point aux Pins) to its intersection with the southern boundary. The lateral extent of Unit 8 is the MHW line on each shoreline of the included water bodies or the entrance to rivers, bayous, and creeks. Pascagoula Channel, a major shipping channel, as identified on standard navigation charts and marked by buoys, is excluded.

Unit 8 provides juvenile, sub-adult, and adult feeding, resting, and passage habitat for Gulf sturgeon from the Pascagoula and the Pearl River sub-populations (68 FR 13395); fish are consistently located both inshore and around/between the barrier islands (i.e., Cat, Ship, Horn, and Petit Bois) within this unit (Reynolds 1993; Rogillio et al. 2001; Ross et al. 2001a). Gulf

sturgeon have also been documented within one nm of the barrier islands of Mississippi Sound. Substrate in this unit ranges from sand to silt, which contain known Gulf sturgeon prey items, including lancelets (Menzel 1971; Abele and Kim 1986; AFS 1989; Heise et al. 1999; Rogillio et al. 2001; Ross et al. 2001a). Four PCEs are present in critical habitat Unit 8: abundant prey items for sub-adults and adults, water quality, sediment quality, and safe and unobstructed migratory pathways. Unit 8 of Gulf sturgeon critical habitat encompasses a total of 3,567 km<sup>2</sup> (881,421 acres). The amount of benthos impacted by the disposal of material (43.03 km<sup>2</sup> or 10,633.43 acres) constitutes 1.21 percent of the total area within the unit.

Mississippi Sound is an arm of the Gulf of Mexico that extends from Lake Borgne, Louisiana, on the west to Mobile Bay, Alabama, on the east. The sound is about 100 mi (161 km) long and 7 to 15 mi (11-24 km) wide and is mostly unstratified brackish water. The sound is part of the Intracoastal Waterway and is separated from the Gulf by a series of narrow islands and sandbars. Two major rivers (Pearl and Pascagoula) flow into Mississippi Sound. In addition, Mississippi Sound receives water from both the Gulf of Mexico to the south and from the drainage basins of Biloxi Bay and St. Louis Bay. About 80 percent of Mississippi Sound has been designated as Gulf sturgeon critical habitat.

Mississippi Sound contains a number of different submerged aquatic communities, including seagrass beds, marine algae, mollusk reef, unconsolidated bottom communities, oyster beds, and salt marsh. The beaches that border Mississippi Sound on the north are manmade and are maintained on an annual and periodic basis; the beaches on the barrier islands are natural. A number of barrier islands exist off the coast including Cat, Ship, Horn, and Petit Bois. The barrier islands significantly reduce the penetration of long swells from the Gulf of Mexico, resulting in relatively low energy waves (< 1 ft) in the sound. However, hurricanes and strong winter cold fronts can produce surges and much larger wave conditions at the coast, which in turn increases sediment transport. Circulation within the sound is influenced by the freshwater outflow from rivers and bays, seasonal easterly and westerly winds, tidal-driven flow that enters the sound through the barrier island passes, and the Loop Current (ocean current within the Gulf of Mexico) that has a counterclockwise spire just south of the barrier islands.

A substantial portion of coastal Mississippi Sound has been developed into urban, industrial, and residential uses. Much of this urban development is highly concentrated between Pascagoula and Bay St. Louis, Mississippi; some urban growth is centered around industrial development and a commercial fishing industry. Population growth during the past three decades has been characterized by alternating periods of robust growth and stagnation. Over the past decade or so, the development of a casino industry centered around Biloxi, Mississippi, and the construction of a naval base, has spurred both population and economic growth in nearby Harrison, Hancock, and Jackson Counties.

The biological and natural resources in the Mississippi Sound are many. The aquatic resources include aquatic plants, invertebrates, reptiles, birds, fish, and marine mammals. There are numerous gas fields in Mississippi Sound and the potential of additional oil and gas reserves. Each individual state regulates drilling, production, and storage at inshore and nearshore sites; the Minerals Management Service (MMS), a bureau in the U.S. Department of the Interior, is the

federal agency that manages the nation's natural gas, oil, and other mineral resources on the outer continental shelf.

Sediment layers in the Mississippi Sound are from the Pliocene, Miocene, Oligocene, and Eocene epoch. These sediments and sedimentary rocks consist of clay, silt, sand, gravel, and limestone. Most sediments in the north are a result of a river system (ancestral to the current Mississippi River) that drained the rising continental interior and deposited sediments from throughout the large continental drainage area into the Gulf of Mexico; sediments in the south may be of marine origin. Mississippi Sound sediments are relatively uncontaminated. Mississippi Sound is reported to have limited areas (about 6 percent) with high sediment contamination levels; nearby Mobile Bay (61 percent), Perdido Bay (92 percent), and Pensacola Bay (62 percent) estimates are much higher (EPA EMAP-E database).

Dredging commonly occurs in Mississippi Sound; the majority is conducted by the MDCOE. Most dredging in Mississippi Sound is conducted to allow for safe navigation; the majority of projects are to maintain waterways, some are for improvement (deepening or widening). Annually, MDCOE dredges and moves about 250 million cubic yards (five-year average), most (75-80 percent) of which occurs in the sound.

## **4.2 Factors affecting critical habitat within the action area**

Gulf sturgeon critical habitat Unit 8 is a spatially defined area that includes winter-feeding and migratory habitat for two sub-populations. Changing the sediment character could appreciably impair normal Gulf sturgeon behavior; additionally, it could restructure the benthic community, thus reducing the availability of prey items. Channel dredging activities, upland activities, and poor dredge-and-fill practices could impact water quality in the unit.

### **4.2.1 Federal actions**

Federal agencies that consult on potential impacts to Gulf sturgeon critical habitat include the COE, the Department of Defense (DOD), the Environmental Protection Agency (EPA), the Federal Energy Regulatory Commission (FERC), and the Nuclear Regulatory Commission (NRC). Dredging and dredged material disposal and military activities, including training exercises and ordnance detonation, have the potential to impact designated critical habitat. While numerous formal consultations have been conducted on potential impacts to the species, NMFS has conducted less than twenty formal consultations on potential impacts to Gulf sturgeon critical habitat since the effective date (April 18, 2003). USFWS has also conducted less than 20 formal consultations to ascertain potential project impacts on designated Gulf sturgeon critical habitat (J. Ziewitz, USFWS, pers. comm., February 2007). The previous formal consultations conducted by NMFS concluded that proposed actions would not result in the destruction or adverse modification of critical habitat. Numerous informal consultations with the DOD, COE, EPA, FERC, and NRC analyzing potential impacts to designated critical habitat have been conducted.

Numerous nationwide COE permits exist for wetland mitigation throughout Mississippi Sound. NMFS recently updated the GMRBO (NMFS 2007), which includes maintenance dredging in

Gulf sturgeon critical habitat Units 8-14. It concluded when channels within designated critical habitat are dredged to only their current depth, without improvements (i.e., deepening or widening), the project will not destroy or adversely modify Gulf sturgeon critical habitat. However, major shipping channels such as those included in the Gulfport Harbor Navigation Project are excluded from, and not considered as part of, Gulf sturgeon critical habitat, as specified by 50 CFR §226.214(h)(2).

Federally regulated storm water and industrial discharges and chemically treated discharges from sewage treatment systems may impact Gulf sturgeon critical habitat. NMFS continues to consult with EPA to minimize the effects of these activities on both listed species and designated critical habitat. In addition, other federally permitted construction activities, such as beach restoration, have the potential to impact Gulf sturgeon critical habitat.

#### **4.2.2 State or private actions**

A number of activities that may indirectly affect Gulf sturgeon critical habitat Unit 11 include discharges from wastewater systems, dredging, ocean dumping and disposal, and aquaculture. The impacts from these activities are difficult to measure. Where possible, however, conservation actions through the ESA section 7 process, ESA section 10 permitting, and state permitting programs are being implemented to monitor or study impacts from these sources.

Increasing coastal development and ongoing beach erosion will result in increased demands by coastal communities, especially beach resort towns, for periodic privately funded or federally sponsored beach renourishment projects. These activities may affect Gulf sturgeon critical habitat by burying nearshore habitats that serve as foraging areas.

#### **4.2.3 Conservation and recovery actions shaping the environmental baseline**

Actions impacting wetlands abutting Gulf sturgeon critical habitat throughout Apalachicola Bay are regulated, managed, and mitigated via numerous COE nationwide permits.

Federal EFH consultation requirements pursuant to the Magnuson-Stevens Fishery Management and Conservation Act minimize and mitigate for losses of wetlands, and preserve valuable foraging and developmental habitat for Gulf sturgeon.

### **5 EFFECTS OF THE ACTION ON GULF STURGEON CRITICAL HABITAT**

As discussed above, critical habitat Unit 8 contains four PCEs that may be affected by the proposed project: water quality, migratory pathways, sediment quality, and abundant prey items. However, with the exception of prey abundance, NMFS expects the effects of the proposed action will not affect or will only have insignificant effects on these PCEs. Therefore, only potential impacts on prey abundance are analyzed below. This biological opinion does not rely on the regulatory definition of "destruction or adverse modification" of critical habitat at 50 CFR 402.02. Instead, we have relied upon the statutory provisions of the ESA to complete the following analysis with respect to critical habitat.

In other opinions, NMFS has considered and analyzed the following factors to determine direct and indirect effects of projects impacting Gulf sturgeon prey abundance essential to the conservation of the Gulf sturgeon: Gulf sturgeon sub-populations using affected critical habitat, mean generation time, foraging method, prey items, benthic community structure, potential Gulf sturgeon prey in action area, and recovery of benthic biota. Whether individual factors are relevant to a particular action and are analyzed within an opinion is highly site and fact specific. NMFS determines and assesses relevant factors in order to predict the persistence and resilience of the prey resource with regard to density of both current and recovering Gulf sturgeon populations. That is, numerous variables depicting Gulf sturgeon prey are utilized to determine the likelihood of appropriate and abundant prey in the unit following the project to ensure that the action is not likely to result in the destruction or adverse modification of the PCE. Of the aforementioned factors, NMFS has determined that only the following are relevant to the proposed action and hence analyzed in this opinion to assess direct and indirect effects of the proposed action on the abundance of prey in Unit 8:

1. Gulf sturgeon sub-populations using affected critical habitat;
2. Prey items;
3. Benthic community structure;
4. Recovery of benthic biota; and
5. Potential Gulf sturgeon prey in action area.

#### *Gulf sturgeon sub-populations using affected critical habitat*

Overall, Gulf sturgeon critical habitat Unit 8 provides juvenile, sub-adult, and adult feeding, resting, and passage habitat for Gulf sturgeon from the Pascagoula and the Pearl Rivers. The project area is located about midway between the Pearl and Pascagoula Rivers. Ross et al. (2001a; 2001b) have investigated the movement of fish exiting the nearby Pascagoula River (n=19) and concluded that the fish locate in or near the barrier island (Cat, Ship, Horn, and Petit Bois Islands) passes (Ross et al. 2001a) in the clean sand substrates. Rogillio et al. (2001) tracked fish from the Pearl River (n=25) and all fish relocated (n=7) were also found near the barrier islands. After three months of systematic survey, no fish were located nearshore, or in Lakes Pontchartrain or Borgne. Incidental capture of a sturgeon tagged in the Pearl River near Breton Island, Louisiana, supports the concept that Gulf sturgeon utilize barrier island sites in the winter (Rogillio et al. 2001). Preference for sandy habitat is supported by studies in other areas that have correlated Gulf sturgeon presence to sandy substrate (Fox et al. 2002).

The actual number of Gulf sturgeon utilizing the project area for foraging is, at this time, likely few. Few data describing the population size and structure of Gulf sturgeon are available. Of the nine major rivers that are known to support Gulf sturgeon (Pearl, Pascagoula, Escambia, Yellow, Conecuh, Choctawhatchee, Apalachicola, Suwannee, and Withlacoochee), population estimates have been calculated only for three (Apalachicola, Choctawhatchee, and Suwannee Rivers). NMFS believes that Gulf sturgeon population size within the other six major rivers is small. Therefore, the number of Gulf sturgeon from the two rivers (i.e., Pearl and Pascagoula Rivers) that likely utilize the project area and that would be affected by an impacted prey base is presumably few, but likely to increase as species recovery occurs.

#### *Prey items*

Ontogenetic changes in Gulf sturgeon diet and foraging area have been documented. Young-of-the-year forage in freshwater on aquatic invertebrates and detritus (Mason and Clugston 1993; Sulak and Clugston 1999); juveniles forage throughout the river on aquatic insects (e.g., mayflies and caddis flies), worms (oligochaete), and bivalves (Huff 1975; Mason and Clugston 1993); adults forage sparingly in freshwater and depend almost entirely on estuarine and marine prey for their growth (Gu et al. 2001). Both adult and sub-adult Gulf sturgeon are known to lose up to 30 percent of their total body weight while in freshwater, and subsequently compensate the loss during winter feeding in marine areas (Carr 1983; Wooley and Crateau 1985; Clugston et al. 1995; Morrow et al. 1998; Heise et al. 1999; Sulak and Clugston 1999; Ross et al. 2000). Therefore, once Gulf sturgeon leave the river after having spent at least six months in the river fasting, it is presumed that they immediately begin feeding. Upon exiting the rivers, Gulf sturgeon concentrate around the mouths of their natal rivers in lakes and bays. These areas are very important for the Gulf sturgeon as they offer the first foraging opportunity for the Gulf sturgeon exiting the rivers.

Few data have been collected on the food habits of Gulf sturgeon; their threatened status limits sampling efforts and gastric lavaging has only recently become successful. Gulf sturgeon have been described as opportunistic and indiscriminate benthivores; their guts generally contain benthic marine invertebrates including amphipods, lancelets, polychaetes, gastropods, shrimp, isopods, molluscs, and crustaceans (Huff 1975; Mason and Clugston 1993; Carr et al. 1996; Fox et al. 2000; Fox et al. 2002). During the early fall and winter, immediately following downstream migration, Gulf sturgeon are most often located in nearshore (depth less than 20 ft) sandy areas that support burrowing macroinvertebrates, where the fish are presumably foraging (Craft et al. 2001; Ross et al. 2001; Fox et al. 2002). Generally, Gulf sturgeon prey are burrowing species (e.g., annelids: polychaetes and oligochaetes, amphipods, isopods, and lancelets) that feed on detritus and/or suspended particles, and inhabit sandy substrate.

#### *Benthic community structure*

In most areas, community structure of the benthos is unknown. Without a comprehensive benthic survey, availability of Gulf sturgeon prey remains uncertain. Most of what is known about the community structure of sandy benthic communities of the northern Gulf of Mexico is the result of work by Saloman et al. (1982), Culter and Mahadevan (1982), and Rakocinski et al. (1991; 1993). While none of these reports describe the benthic community in or near the project area, the community structure described by Rakocinski et al. (1991; 1993) is likely similar to the project areas as both sites are comprised predominantly of sand.

Two areas will be impacted by this action: nearshore borrow areas and the swash zone. Community structure at the nearshore borrow areas, based on Rakocinski et al. (1991; 1993; 1996), is likely to be predominantly cumacean (*Cyclaspis* cf. *varians*) and polychaete (*Streptosyllis pettiboneae* and *Nephtys bucera*). The mole crab (*Emerita talpoida*), spinoid polychaete (*Scolecopsis squamata*), and wedge clam (*Donax variabilis*) likely dominate the swash zone, with some occurrence of polychaetes (*Dispio uncinata*, *Leitoscoloplos fragilis*, and *Paraonis gracilis*), haustoriid amphipods (*Haustorius jaynae*), isopods (*Ancinus depressus* and *Exosphaeroma diminutum*), and the mysid shrimp (*Metamysidospis swiftii*).

#### *Recovery of benthic biota*



Rate and success of benthic recovery resulting from placement of dredged material is a function of sediment texture, depth of overburden, time of year, and habitat type. Placement of materials similar to ambient sediments (e.g., sand on sand or mud on mud) has been shown to produce less severe impacts in contrast to placement of dissimilar sediments, which generally results in more severe, long-term impact (Maurer et al. 1978). Deposition of dredged material in extremely thin layers (<10 cm; 4 in) can minimize impacts by allowing many populations of small, shallow-burrowing infauna with characteristically high reproductive rates and wide dispersal capabilities to recover quickly. Deposits greater than 20-30 cm (8-12 in) generally eliminate all but the largest and most vigorous burrowers (Maurer et al. 1978).

Observed rates of benthic community recovery after dredged material placement range from a few months to several years. The relatively species-poor benthic assemblages associated with low salinity estuarine sediments can recover in periods of time ranging from a few months to approximately one year (Leathem et al. 1973; McCauley et al. 1976; 1977; Van Dolah et al. 1979; 1984; Clarke and Miller-Way 1992), while the more diverse communities of high salinity estuarine sediments may require a year or longer (e.g., Jones 1986). Succession within the project area, as discussed in the report from the National Demonstration Project, could begin within a few days as larvae settle during seasonal recruitment (MDCOE 1999).

#### *Potential Gulf sturgeon prey in the action area*

Research in Choctawhatchee Bay (Fox and Hightower 1998; Fox et al. 2002) indicates that Gulf sturgeon show a preference for sandy shoreline habitats with the majority of fish being located in areas lacking seagrass. Craft et al. (2001) found that Gulf sturgeon in Pensacola Bay prefer shallow shoals with unvegetated, fine- to medium-grain sand habitats such as sandbars and subtidal energy zones resulting in sediment sorting and a preponderance of sand supporting a variety of prey items. Habitats used nearby the Mississippi Sound barrier islands tend to have a clean sand substrate and all benthic samples from the area contained lancelets (Ross et al. 2001a). Other nearshore Gulf of Mexico locations where Gulf sturgeon are often located (via telemetry and tag returns) consist of unconsolidated, fine-medium grain sand habitats, including natural inlets and passes that are known to support Gulf sturgeon prey items (Menzel 1971; Abele and Kim 1986; AFS 1989). It has been concluded that Gulf sturgeon are foraging in these sandy areas where they are repeatedly located, as this habitat supports their prey (see preceding "Prey items" section for specifics).

#### *Summary of effects on Gulf sturgeon prey abundance*

Gulf sturgeon prey abundance, the only PCE likely to be adversely affected by the proposed action, has the ability to recover and recolonize, and therefore its resilience to the action should be considered. Recovery of the macrobenthic assemblages is expected to be rapid as sediment composition pre- and post-construction will be similar, and nearshore benthic assemblages are known to recover relatively quickly from physical disturbance.

While habitat known to support prey will be impacted, there are no telemetry data to indicate that Gulf sturgeon selectively utilize the project area. It is likely when Gulf sturgeon enter the project area following their fall migration, they will find appropriate and abundant prey in the areas adjacent to the project location. Given that the sturgeon forage opportunistically while benthic cruising, they can easily locate prey and fulfill nutritional requirements in areas adjacent to those

impacted. Thus, the temporary reduction of benthic prey availability (<1 year) in an area that constitutes 1.21 percent of critical habitat Unit 8 may adversely affect but will not destroy or adversely modify this PCE's capacity within critical habitat Unit 8 to support the Gulf sturgeon's conservation in the short- or long-term.

## **5.5 Summary of effects on Gulf sturgeon critical habitat**

Based on the description of the proposed action, and the preceding discussions and analysis presented in Sections 5.1. through 5.4, NMFS concludes that project impacts may adversely affect but will not destroy or adversely modify the critical habitat's ability to support the Gulf sturgeon's conservation in the short- or long-term.

## **6 CUMULATIVE EFFECTS**

ESA section 7 regulations require NMFS to consider cumulative effects in formulating their biological opinions (50 CFR 402.14). Cumulative effects include the effects of future state, tribal, local, or private actions that are reasonably certain to occur in the action area considered in this opinion. Because many activities that affect marine habitat involve some degree of federal authorization (e.g., through MMS or COE), NMFS expects that ESA section 7 will apply to most future major actions that could affect designated Gulf sturgeon critical habitat Unit 8.

## **7 CONCLUSION**

After reviewing the current status of Gulf sturgeon critical habitat Unit 8, the environmental baseline, the effects of the proposed action, and the cumulative effects, it is NMFS' biological opinion that the effects of the proposed placement of dredged materials into disposal areas within Gulf sturgeon critical habitat will not reduce the critical habitat's ability to support the Gulf sturgeon's conservation. NMFS concludes that the action, as proposed, is not likely to destroy or adversely modify designated Gulf sturgeon critical habitat.

## **8 INCIDENTAL TAKE STATEMENT**

NMFS does not anticipate that the proposed action will incidentally take any species and no take is authorized. However, any takes of sea turtles or Gulf sturgeon will be counted against the ITS of the GMRBO, and the RPMs and terms and conditions of that ITS are applicable to this action.

## **9 CONSERVATION RECOMMENDATIONS**

Section 7(a)(1) of the ESA directs federal agencies to utilize their authority to further the purposes of the ESA by carrying out conservation programs for the benefit of endangered and threatened species. Conservation recommendations are discretionary agency activities to minimize or avoid adverse effects of a proposed action on listed species, to help implement recovery plans, or to develop information. NMFS believes that MD COE should implement the following conservation recommendations:



1. Gather data describing community structure of the benthos in and near the project area that would help to determine local Gulf sturgeon prey availability and thereby assist in future assessments of impacts to designated critical habitat; and
2. Gather data describing recovery rates of benthic assemblages impacted by the deposition of dredged material into designated disposal areas that would assist in future assessments of impacts to Gulf sturgeon prey items.

In order for NMFS to be kept informed of actions minimizing or avoiding adverse effects or benefiting listed species or their habitats, NMFS requests notification of the implementation of any conservation recommendations.

## 10 REINITIATION OF CONSULTATION

This concludes formal consultation on the disposal of materials associated with maintaining Gulfport Harbor Navigation Project in Mississippi Sound, Harrison County, Mississippi. As provided in 50 CFR 402.16, reinitiation of formal consultation is required where discretionary federal agency involvement or control over the action has been retained (or is authorized by law) and if (1) the amount or extent of taking specified in the incidental take statement is exceeded, (2) new information reveals effects of the action that may affect listed species or critical habitat in a manner or to an extent not previously considered, (3) the identified action is subsequently modified in a manner that causes an effect to listed species or critical habitat that was not considered in the biological opinion, or (4) a new species is listed or critical habitat designated that may be affected by the identified action.

## 11 LITERATURE CITED

- Abele, L.G. and W. Kim. 1986. An illustrated guide to the marine crustaceans of Florida. Technical Series Vol. 1 Number 1 Part 1. November 1986. Department of Environmental Regulation, State of Florida. p. 326.
- AFS (American Fisheries Society). 1989. Common and scientific names of aquatic invertebrates from the United States and Canada: decapod crustaceans. Special Publication 17, Bethesda, MD. 77 pp.
- Carr, A. 1983. All the way down upon the Suwannee River. Audubon Magazine 85: 78-101.
- Carr, S.H., F. Tatman, and F.A. Chapman. 1996. Observations on the natural history of the Gulf of Mexico sturgeon (*Acipenser oxyrinchus desotoi* Vladykov 1955) in the Suwannee River, southeastern United States. Ecology of Freshwater Fish 5: 169-174.
- Clarke, D.G. and T. Miller-Way. 1992. An environmental assessment of the effects of open-water disposal of maintenance dredged material on benthic resources in Mobile Bay, Alabama. U.S. Army Corps of Engineers, Waterways Experiment Station, Vicksburg, MS, Miscellaneous Paper D-92-1, 40 pp.

- Clugston, J.P., A.M. Foster, and S.H. Carr. 1995. Gulf sturgeon, *Acipenser oxyrinchus desotoi*, in the Suwannee River, Florida. Pp. 215-224 In: A.D. Gershanovich and T.I.J. Smith (eds.), Proceedings of International Symposium on Sturgeons, Moscow, Russia. September 6-11, 1993. 370 pp.
- Craft, N.M., B. Russell, and S. Travis. 2001. Identification of Gulf sturgeon spawning habitats and migratory patterns in the Yellow and Escambia River systems. Final Report to the Florida Marine Research Institute, Fish and Wildlife Conservation Commission. 19 pp.
- Culter, J.K. and S. Mahadevan. 1982. Long-term effects of beach nourishment on the benthic fauna of Panama City Beach, Florida. U.S. Army Corps of Engineers Coastal Engineering Research Center Miscellaneous Report No. 82-2. 57 pp.
- Foster, A.M. and J.P. Clugston. 1997. Seasonal migration of Gulf sturgeon in the Suwannee River, Florida. Transactions of the American Fisheries Society 126: 302-308.
- Fox, D.A. and J.E. Hightower. 1998. Gulf sturgeon estuarine and nearshore marine habitat use in Choctawhatchee Bay, Florida. Annual Report for 1998 to the National Marine Fisheries Service and the U.S. Fish and Wildlife Service. Panama City, FL. 29 pp.
- Fox, D.A., J.E. Hightower, and F.M. Parauka. 2000. Gulf Sturgeon, Spawning Migration and Habitat in the Choctawhatchee River System, Alabama-Florida. Transactions of the American Fisheries Society 129: 811-826.
- Fox, D., J.E. Hightower, and F. Parauka. 2002. Estuarine and nearshore marine habitat use by Gulf sturgeon from the Choctawhatchee River system, Florida. American Fisheries Society Symposium 28: 111-126
- Gu, B., D.M. Schell, T. Frazer, M. Hoyer, and F.A. Chapman. 2001. Stable carbon isotope evidence for reduced feeding of Gulf of Mexico sturgeon during their prolonged river residence period. Estuarine, Coastal and Shelf Science 53: 275-280.
- Heise, R.J., S.T. Ross, M.F. Cashner, and W.T. Slack. 1999. Movement and habitat use of the Gulf sturgeon (*Acipenser oxyrinchus desotoi*) in the Pascagoula drainage of Mississippi: year III. Museum Technical Report No. 74. Funded by U.S. Fish and Wildlife Service, Project No. E-1, Segment 14.
- Huff, J.A. 1975. Life history of the Gulf of Mexico sturgeon, *Acipenser oxyrinchus desotoi*, in the Suwannee River, Florida. Marine Resources Pub. No. 16. 32 pp.
- Jones, A. 1986. The effects of dredging and spoil disposal on macrobenthos, Hawkesbury Estuary, New South Wales. Marine Pollution Bulletin 17: 17-20.
- Leathem, W., P. Kinner, D. Maurer, R. Briggs and W. Treasure. 1973. Effect of spoil disposal on benthic invertebrates. Marine Pollution Bulletin 4: 122-125.

- Mason, W.T., Jr., and J.P. Clugston. 1993. Foods of the Gulf sturgeon *Acipenser oxyrhynchus desotoi* in the Suwannee River, Florida. Transactions of the American Fisheries Society 122: 378-385.
- Maurer, D., R. Keck, J. Tinsman, W. Leathem, C. Wethe, M. Hutzinger, C. Lord and T. Church. 1978. Vertical migration of benthos in simulated dredged material overburdens. Volume I: Marine benthos. U. S. Army Engineer Waterways Experiment Station, Vicksburg, MS. Dredged Material Research Program. Technical Report No. D-78-35.
- McCauley, J.E., D.R. Hancock and R.A. Parr. 1976. Maintenance dredging and four polychaete worms. Pp. 673-683 *In: Proceedings of the Specialty Conference on Dredging and Its Environmental Effects, Mobile, AL.*
- McCauley, J.E., R.A. Parr and D.R. Hancock. 1977. Benthic infauna and maintenance dredging: a case study. Water Research 11: 233-242.
- McIntyre, A.D. 1969. Ecology of marine meiobenthos. Biological Review 44:245-290.
- MDCOE (Mobile District Corps of Engineers). 1999. National demonstration program thin-layer dredged material disposal Gulfport, Mississippi, 1991-1992. Final Report. Vol. I - IV.
- Menzel, R.W. 1971. Checklist of the Marine Fauna and Flora of the Apalachee Bay and the St. George Sound Area. Third Edition. The Department of Oceanography, Florida State University. Tallahassee, FL. 126 pp.
- Morrow, J.V. Jr., K.J. Killgore, J.P. Kirk, and H.E. Rogillio. 1998. Distribution and population attributes of Gulf Sturgeon in the lower Pearl River System, Louisiana. Proceedings of the Annual Conference Southeastern Association of Fish and Wildlife Agencies 50 (1996):79-90.
- NMFS. 2007. Endangered Species Act section 7 consultation on the dredging of Gulf of Mexico navigation channels and sand mining ("borrow") areas using hopper dredges by COE Galveston, New Orleans, Mobile, and Jacksonville Districts. Revised Biological Opinion (November 2003). January 2007.
- Odenkirk, J.S. 1989. Movements of Gulf of Mexico sturgeon in the Apalachicola River, Florida. Proceedings of the Annual Conference of the Southeastern Association of Fish and Wildlife Agencies. 43:230-238.
- Parauka, F.M., S.K. Alam, and D.A. Fox. *In press*. Pp. 280-297 *In: Movement and habitat use of sub-adult Gulf sturgeon in Choctawhatchee Bay, Florida. 2001 Proceedings Annual Conference SEAFWA.*

- Rakocinski, C.F., R.W. Heard, T. Simons, and D. Gledhill. 1991. Macroinvertebrate associations from beaches of selected barrier islands in the Northern Gulf of Mexico: Important environmental relationships. *Bulletin of Marine Science*. 48: 689-701.
- Rakocinski, C.F., R.W. Heard, S.E. LeCroy, J.A. McLelland, and T. Simons. 1993. Seaward changes and zonation of the sandy shore macrofauna at Perdido Key, Florida, U.S.A. *Estuarine Coastal and Shelf Science* 36: 81-104.
- Reynolds, C.R. 1993. Gulf sturgeon sightings, historic and recent—a summary of public responses. U.S. Fish and Wildlife Service. Panama City, FL. 40 pp.
- Rhoads, D.C., and J.D. Germano. 1986. Interpreting long-term changes in benthic community structure: a new protocol. *Hydrobiologia* 142: 291-308.
- Rogillio, H.E., E.A. Rabalais, J.S. Forester, C.N. Doolittle, W.J. Granger, and J.P. Kirk. 2001. Status, movement and habitat use study of Gulf sturgeon in the Lake Pontchartrain Basin, Louisiana. Louisiana Department of Wildlife and Fisheries. 43 pp.
- Ross, S.T., R.J. Heise, W.T. Slack, J.A. Ewing, III, and M. Dugo. 2000. Movement and habitat use of the Gulf sturgeon (*Acipenser oxyrinchus desotoi*) in the Pascagoula drainage of Mississippi: year IV. Mississippi Department of Wildlife, Fisheries, and Parks and Museum of Natural Science. Funded by U.S. Fish and Wildlife Service, Project No. E-1, Segment 15. 58 pp.
- Ross, S.T., R.J. Heise, W.T. Slack, and M. Dugo. 2001a. Habitat requirements of Gulf Sturgeon (*Acipenser oxyrinchus desotoi*) in the northern Gulf of Mexico. Department of Biological Sciences, University of Southern Mississippi and Mississippi Museum of Natural Science. Funded by the Shell Marine Habitat Program, National Fish and Wildlife Foundation. 26 pp.
- Ross, S.T., R.J. Heise, M.A. Dugo, and W.T. Slack. 2001b. Movement and habitat use of the Gulf sturgeon (*Acipenser oxyrinchus desotoi*) in the Pascagoula drainage of Mississippi: year V. Department of Biological Sciences, University of Southern Mississippi, and Mississippi Museum of Natural Science. Funded by U.S. Fish and Wildlife Service, Project No. E-1, Segment 16.
- Saloman, C.H., S.P. Naughton, and J.L. Taylor. 1982. Benthic community response to dredging borrow pits, Panama City Beach, Florida. U.S. Army Corps of Engineers, Coastal Engineering Research Center, Fort Belvoir, VA, Miscellaneous Report No. 82-3. 138 pp.
- Sulak, K.J. and J.P. Clugston. 1999. Recent advances in life history of Gulf of Mexico sturgeon *Acipenser oxyrinchus desotoi* in the Suwannee River, Florida, U.S.A.: a synopsis. *J. Appl. Ichth.* 15: 116-128.
- USFWS, GSMFC, and NMFS. 1995. U.S. Gulf sturgeon Recovery/Management Plan. Atlanta, Georgia. 170 pp.

APPENDIX B

USEPA ENVIROFACTS REPORTS

---





**Envirofacts**  
**FRS Facility Detail Report**



**JOSEPH T JONES HARBOR**

2265 JONES PARK DRIVE  
GULFPORT, MS 39501  
EPA Registry Id: 110044668133

Facility Registry Service Links

- Search
- [FRS Facility Query](#)
- [FRS EZ Search](#)
- [Organization Search](#)
- [FRS Physical Data Model](#)
- [FRS Geospatial Model](#)
- [Contact Us](#)
- [Facility Registry Service \(FRS\) Home](#)

[Report an Error](#)

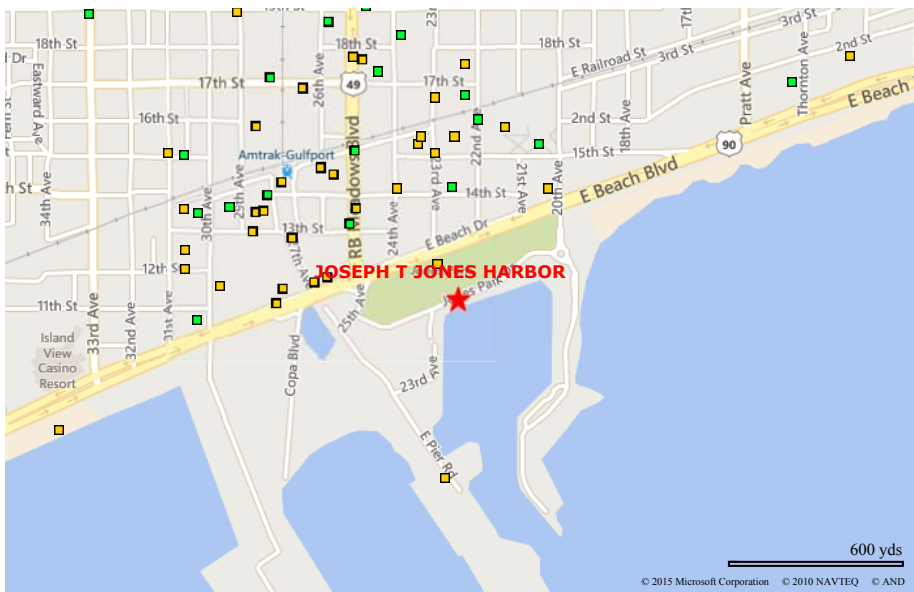

**Legend**

- ★ Selected Facility
- EPA Facility of Interest
- State/Tribe Facility of Interest

The facility locations displayed come from the FRS Spatial Coordinates tables. They are the best representative locations for the displayed facilities based on the accuracy of the collection method and quality assurance checks performed against each location. The North American Datum of 1983 is used to display all coordinates.

**Environmental Interests**

Information System	System Facility Name	Information System Id/Report Link	Environmental Interest Type	Data Source	Last Updated Date	Supplemental Environmental Interests:
<a href="#">MISSISSIPPI - TOOLS FOR ENVIRONMENTAL MANAGEMENT AND PROTECTION ORGANIZATIONS</a>	JOSEPH T JONES HARBOR	<a href="#">26501</a>	STATE MASTER	MS-ENSITE		-26501 STATE MASTER -12311 UNDERGROUND STORAGE TANI PROGRAM

Additional EPA Reports: [MyEnvironment](#) [Site Demographics](#) [Facility Coordinates Viewer](#) [Environmental Justice Map Viewer](#) [Watershed Report](#)

**Standard Industrial Classification Codes (SIC)**

Data Source	SIC Code	Description	Primary
MS-ENSITE	5541	GASOLINE SERVICE STATIONS	

**National Industry Classification System Codes (NAICS)**

No NAICS Codes returned.  
**Facility Mailing Addresses**

Affiliation Type	Delivery Point	City Name	State	Postal Code	Information System
MAILING ADDRESS	2309 15TH STREET	GULFPORT	MS	39501	MS-ENSITE

**Contacts**

No Contacts returned.

<b>EPA Region:</b>	04
<b>Duns Number:</b>	
<b>Congressional District Number:</b>	04
<b>Legislative District Number:</b>	
<b>HUC Code/Watershed:</b>	03170009 / MISSISSIPPI COASTAL
<b>US Mexico Border Indicator:</b>	
<b>Federal Facility:</b>	NO
<b>Tribal Land:</b>	

**Alternative Names**

No Alternative Names returned.

**Organizations**

No Organizations returned.

Query executed on: SEP-12-2015



**Envirofacts**  
**FRS Facility Detail Report**



**GULFPORT YACHT CLUB PROJECT**

GULFPORT, MS 39501  
EPA Registry Id: 110044624813

- Facility Registry Service Links
- Search
  - [FRS Facility Query](#)
  - [FRS EZ Search](#)
  - [Organization Search](#)
  - [FRS Physical Data Model](#)
  - [FRS Geospatial Model](#)
  - [Contact Us](#)
  - [Facility Registry Service \(FRS\) Home](#)
- [Report an Error](#)



**Legend**

- ★ Selected Facility
- EPA Facility of Interest
- State/Tribe Facility of Interest

The facility locations displayed come from the FRS Spatial Coordinates tables. They are the best representative locations for the displayed facilities based on the accuracy of the collection method and quality assurance checks performed against each location. The North American Datum of 1983 is used to display all coordinates.

Environmental Interests

Information System	System Facility Name	Information System Id/Report Link	Environmental Interest Type	Data Source	Last Updated Date	Supplemental Environmental Interests
<a href="#">MISSISSIPPI - TOOLS FOR ENVIRONMENTAL MANAGEMENT AND PROTECTION ORGANIZATIONS</a>	GULFPORT YACHT CLUB PROJECT	35653	STATE MASTER	MS-ENSITE		-WQC2002015 401 CERTIFICATION/COASTAL ZONE MANAGEMENT -35653 STATE MASTER

Additional EPA Reports: [MyEnvironment](#) [Site Demographics](#) [Facility Coordinates Viewer](#) [Environmental Justice Map Viewer](#) [Watershed Report](#)

Standard Industrial Classification Codes (SIC)

No SIC Codes returned.  
**Facility Codes and Flags**

National Industry Classification System Codes (NAICS)

No NAICS Codes returned.  
**Facility Mailing Addresses**

<b>EPA Region:</b> 04	<b>Affiliation Type:</b>	<b>Delivery Point:</b>	<b>City Name:</b>	<b>State:</b>	<b>Postal Code:</b>	<b>Information System:</b>
<b>Duns Number:</b>	MAILING ADDRESS	800 EAST PIER	GULFPORT	MS	39501	MS-ENSITE
<b>Congressional District Number:</b>	<b>Contacts</b>					
<b>Legislative District Number:</b>	No Contacts returned.					
<b>HUC Code/Watershed:</b> 03170009 / MISSISSIPPI COASTAL						
<b>US Mexico Border Indicator:</b>						
<b>Federal Facility:</b> NO						
<b>Tribal Land:</b>						

**Alternative Names**

No Alternative Names returned.  
**Organizations**

No Organizations returned.

Query executed on: SEP-12-2015



## **Appendix F**

### **Hazardous Material Regulatory Review Summary**



## **Appendix F**

### **Hazardous Material Regulatory Review Summary**

This Hazardous Material Regulatory Review Summary includes the regulatory information search compiled from more than 60 databases and records and describes the information resulting from this search. The following list includes the standard environmental records and databases and locations of identified sites relative to the study area (Environmental Data Resources, Inc. [EDR], 2011, 2015): National Priority List (NPL) (1.5-mile search radius); Records of Decision (ROD) (1.5-mile search radius); Comprehensive Environmental Response Compensation and Liability Information System database (CERCLIS) (1.0-mile search radius); Resource Conservation and Recovery Act, Large and Small Quantities Generator list (RCRA-LQG, RCRA-SQG ) (0.75-mile search radius); RCRA Corrective Actions List (CORRACTS) (1.5-mile search radius); RCRA Treatment, Storage, or Disposal Facility List (RCRA-TSDF) (1.0-mile search radius); RCRA Administrative Action Tracking System database (RAATS) (0.5-mile search radius); PCB Activity database (PADS) (0.5-mile search radius); Underground Storage Tank (UST) database (0.75-mile search radius); Aboveground Storage Tank (AST) database (0.75-mile search radius); Leaking Underground Storage Tank (LUST) database (1.0-mile search radius); the state's Solid Waste Facilities/Landfill Sites (SWF/LF) (1.0-mile search radius); Emergency Response Notification System (ERNS) database (0.5-mile search radius); Toxic Release Inventory System (TRIS) database (0.5-mile search radius); Facility Index System (FINDS) database (0.5-mile search radius); State Hazardous Waste Sites records (SHWS) (1.5-mile search radius); Voluntary Evaluation Program Sites (VCP) (1.0-mile search radius); Local list of Landfills/Solid Waste disposal/recycling facilities (SWRCY) (1.0-mile search radius); Federally owned or administered lands, DOD (1.5-mile search radius); Integrated Compliance Information System (ICIS) (0.5-mile search radius); The Hazardous Materials Incident Report System (HMIRS), hazardous material spill incidents reported to the DOT (0.5-mile search radius); and Manufactured Gas Plants list (1.5-mile search radius). Many of these listings were associated with the same industrial facilities or property (e.g., a facility or property contained multiple storage tanks and/or was the site of multiple spills or multiple agency enforcement actions). In totaling the results of the multiple searches, duplicate sites under each category were only counted one time per group of reports.

The following provides a summary of the results of the regulatory agency database information search.

#### **NPL Sites**

The NPL is a priority subset of the CERCLIS list and is a list of priority sites that the EPA has determined to pose a threat to human health and/or the environment and where remedial action is required. No NPL sites were identified within the search area.

**ROD Sites**

The ROD document defines the mandate to perform remedial action at an NPL site. The ROD will contain technical guidance to assist in the cleanup of the facility. No ROD facilities were identified within the search area.

**PADS Sites**

The PADS identifies generators, transporters, commercial storers, and/or brokers and disposers of polychlorinated biphenyls (PCBs) who are required to notify the EPA of such activity. No PADS facilities were identified within the search area.

**CERCLIS/CORRACTS Sites**

The CERCLIS database is EPA's official repository for site and nonsite-specific Superfund data in support of the CERCLA. The database contains information on hazardous waste site assessment and remediation from 1983 to the present and is used by EPA in evaluating the status and progress of site cleanup actions and to communicate planned activities and budgets. The CORRACTS database includes typically a subset of CERCLIS sites with RCRA corrective action activity. The database search identified no CERCLIS sites and no CORRACTS sites within the search area.

**RAATS Sites**

The RAATS database contains records on enforcement actions issued under the Resource Conservation and Recovery Act (RCRA) and pertaining to major violators. It includes administrative and civil actions brought by the EPA. No RAATS facilities were identified within the search area.

**RCRA Treatment, Storage, and Disposal Sites**

The RCRA-TSDF database is also a subset of RCRIS. The database tracks facilities that treat, store, or dispose of hazardous materials, which are required to provide information to State agencies and EPA. No RCRA-TSDF facilities were identified within the search area.

**TRIS Sites**

The TRIS database contains information on chemical releases to environmental media based on reports provided to EPA from individual facilities. The TRIS was mandated by Title III of the Superfund Amendments and Reauthorization Act and was enacted to provide information to the public about releases of toxic chemicals. According to the regulatory agency review report, no TRIS sites were reported within the search area.

**RCRA Generator Sites**

Under RCRA, generators and transporters of hazardous waste are required to provide information concerning their activities to state agencies and the EPA. The RCRA-G (generator) list is a subset of the RCRIS database and tracks facilities that are registered generators or transporters of hazardous waste. Small quantity generators (SQGs) generate at least 100 kilograms (kg)/month, but less than 1,000 kg/month, of hazardous waste. According to the regulatory review, no LQG sites are located within the search area. Sites meeting certain criteria (less than 100 kg/month of hazardous waste) can also be classified as Conditionally Exempt (CE) SQG sites. No regular RCRA-SQG sites were identified in the search area. Sixteen RCRA-CESQG sites are located within the search area. The RCRA-CESQG site locations range from 0.122 mile west-northwest to 0.724 mile north-northeast of the Port.

**RCRA Non-Generator Sites**

The RCRA Info database includes selective information on sites that generate, transport, store, treat and/or dispose of hazardous waste as defined by the RCRA. Non-Generators (NonGen) do not presently generate hazardous waste. A review of the RCRA-NonGen list indicated that there are four RCRA-NonGen sites within the search area. The four site locations range from 0.142 mile west to 0.603 mile northeast of the Port.

**Registered Storage Tanks Sites (UST, AST)**

The UST database is maintained by MDEQ to track permitted petroleum storage tank sites. USTs are regulated under Subtitle I of the RCRA. The EPA regulates all ASTs located in Mississippi. According to the database, 31 facilities operate (or formerly operated) USTs within the search area. Location distances range from 0.034 mile north-northwest to 0.700 mile west of the Port.

The EPA Region 4 Emergency Response Program administrates the AST Program. The AST database, which contains registered ASTs, identified one AST site within the search area, which was 0.636 mile north of the Port.

**LUST Sites**

The LUST database is a list maintained by MDEQ of facilities where a known UST release has occurred. According to the database, a total of 16 sites within the search area are reported as LUST sites. Final concurrence has been issued by MDEQ and the cases have been closed for 13 of the 16 LUST facilities. Final concurrence is pending on three of the sites. The LUST site locations range from 0.120 mile east-northeast to 0.981 mile west-southwest of the Port.

**ERNS/State Spill Sites**

The ERNS is a national computer database used to store information on releases of oil and hazardous substances. The ERNS supports the Emergency Response and the Title III program. The ERNS program is a cooperative effort among EPA Headquarters, the DOT, National Transportation Systems Center (NTSC), the 10 EPA Regions, the U.S. Coast Guard (USCG), and the National Response Center (NRC). The ERNS provides the most comprehensive data compiled on release notifications of oil and hazardous substances in the United States. The ERNS supports the release notification requirements of CERCLA and serves as a mechanism to document and verify incident location information as initially reported. Many of these cases occur at a single facility/property, and the spill or release locations are usually difficult to locate precisely within the facility. The databases searched contained documentation for a total of 33 spill notifications located within the search area. The majority of the sites (27 of the 33) are located along West Beach Boulevard and 23rd Avenue (west-southwest and east of the Port, respectively). Location distances range from 0.066 mile east-northeast to 0.449 mile northeast from the Port.

**FINDS Sites**

The FINDS contains both facility information and “pointers” to other sources of information that contain more detail. The source of this database is the EPA/NTIS. A review of the FINDS list has revealed that there are 29 FINDS sites within the search area. The list is made up of various companies including auto dealerships, automotive shops, manufacturers, and the City of Gulfport sewer system. Location distances range from 0.034 mile north-northwest to 0.496 mile northeast of the Port.

**SWF/LF Sites**

The Solid Waste Facilities/Landfill Sites records typically contain an inventory of solid waste disposal facilities or landfills in a particular state. The data comes from the Department of Environmental Quality’s Solid Waste Landfills. A review of the SWF/LF database revealed that there were no SWF/LF sites within the search area.

**SHWS Sites**

The SHWS records are the state’s equivalent to CERCLIS. Priority sites planned for cleanup using state funds (state equivalent of Superfund) are identified along with sites where potentially responsible parties will pay for cleanup. The data come from the Department of Environmental Quality’s Uncontrolled Site Tracking System. A review of the SHWS list revealed that there are 19 SHWS sites within the search area. Eight of the sites have a State No Further Action (SNFA) status, three sites have an Inactive status, and one site has a SNFA-Reopened status. The remaining seven sites have either an unresolved (not reported) status or Active status. The Active status sites are: Mid South RR Refueling Station, located 0.853 mile north of the Port, and Gulfport Tire, located 1.433 miles northeast of the Port. The nearest site with an

unresolved (not reported) status to the Port is High Tech Services, located 0.243 mile north-northwest of the Port.

### **VCP Sites**

The VCP is a list of state and tribal voluntary cleanup sites. A review of the VCP list revealed that there is one VCP site within the search area. Ameripride Linen and Apparel Services is located 0.238 mile north-northwest of the Port.

### **DOD Sites**

DOD Sites consists of federally owned or administered lands, administered by the DOD, that have any area equal to or greater than 640 acres of the United States or Puerto Rico, and the U.S. Virgin Islands. A review of the DOD list revealed one site within the search area. The Naval Construction Battalion Center is located 0.993 mile north-northwest of the Port.

### **ICIS Sites**

The ICIS supports the information needs of the national enforcement and compliance program as well as the unique needs of the National Pollutant Discharge Elimination System (NPDES) program. A review of the ICIS list revealed that there are three ICIS sites within the search area. The City of Gulfport Sewer System is located at 2309 15th Street, 0.470 mile northeast of the Port. The Bay Ice Company is located at 1413 30th Avenue, 0.310 mile north-northwest of the Port, and the Chiquita Brands, Inc., site is located at Highway 90 & 30th Avenue, which is 0.122 mile west-northwest of the Port.

### **SWRCY Sites**

The SWRCY list contains a listing of recycling facilities. A review of the list revealed that there is one SWRCY site located within the search area. The Harrison County Curbside Recycling Program is located 0.560 mile north-northeast of the Port.

### **Manufactured Gas Plants**

Manufactured gas plant sites were used in the U.S. from the 1800s to 1950s to produce a gas that could be distributed and used as fuel. These plants used whale oil, rosin, coal, or a mixture of coal, oil, and water that also produced a significant amount of waste. Many of the byproducts of the gas production, such as coal tar (oily waste containing volatile and nonvolatile chemicals), sludges, oils, and other compounds are potentially hazardous to human health and the environment. The byproducts from this process were frequently disposed of directly at the plant site and can remain or spread slowly, serving as a continuous source of soil and groundwater contamination. A review of the Manufactured Gas Plants list has revealed that there is one Manufactured Gas Plants site within the search area. The Gulf Cities Gas Company is located at 23rd Avenue, 0.523 mile northeast of the Port.

### **HMIRS Sites**

The HMIRS contains hazardous material spill incidents reported to the Department of Transportation. The source of this database is the EPA. A review of the HMIRS list has revealed that there are no HMIRS sites within the search area.





**Port of Gulfport**

West Beach Boulevard

Gulfport, MS 39501

Inquiry Number: 4407765.3

September 10, 2015

## Certified Sanborn® Map Report



6 Armstrong Road, 4th Floor  
Shelton, Connecticut 06484  
Toll Free: 800.352.0050  
[www.edrnet.com](http://www.edrnet.com)

# Certified Sanborn® Map Report

9/10/15

**Site Name:**

Port of Gulfport  
West Beach Boulevard  
Gulfport, MS 39501

**Client Name:**

Atkins  
10100 Reunion Place Suite 850  
San Antonio, TX 78216



EDR Inquiry # 4407765.3

Contact: Brad Bayne

The Sanborn Library has been searched by EDR and maps covering the target property location as provided by Atkins were identified for the years listed below. The Sanborn Library is the largest, most complete collection of fire insurance maps. The collection includes maps from Sanborn, Bromley, Perris & Browne, Hopkins, Barlow, and others. Only Environmental Data Resources Inc. (EDR) is authorized to grant rights for commercial reproduction of maps by the Sanborn Library LLC, the copyright holder for the collection. Results can be authenticated by visiting [www.edrnet.com/sanborn](http://www.edrnet.com/sanborn).

The Sanborn Library is continually enhanced with newly identified map archives. This report accesses all maps in the collection as of the day this report was generated.

### Certified Sanborn Results:

**Site Name:** Port of Gulfport  
**Address:** West Beach Boulevard  
**City, State, Zip:** Gulfport, MS 39501  
**Cross Street:**  
**P.O. #** 100018536-017.1.X  
**Project:** Port of Gulfport EIS  
**Certification #** 1619-4CF2-8B70



Sanborn® Library search results  
Certification # 1619-4CF2-8B70

**Maps Provided:**

1967  
1950  
1929  
1921  
1912

The Sanborn Library includes more than 1.2 million fire insurance maps from Sanborn, Bromley, Perris & Browne, Hopkins, Barlow and others which track historical property usage in approximately 12,000 American cities and towns. Collections searched:

- Library of Congress
- University Publications of America
- EDR Private Collection

*The Sanborn Library LLC Since 1866™*

**Limited Permission To Make Copies**

Atkins (the client) is permitted to make up to FIVE photocopies of this Sanborn Map transmittal and each fire insurance map accompanying this report solely for the limited use of its customer. No one other than the client is authorized to make copies. Upon request made directly to an EDR Account Executive, the client may be permitted to make a limited number of additional photocopies. This permission is conditioned upon compliance by the client, its customer and their agents with EDR's copyright policy; a copy of which is available upon request.

**Disclaimer - Copyright and Trademark notice**

This Report contains certain information obtained from a variety of public and other sources reasonably available to Environmental Data Resources, Inc. It cannot be concluded from this Report that coverage information for the target and surrounding properties does not exist from other sources. NO WARRANTY EXPRESSED OR IMPLIED, IS MADE WHATSOEVER IN CONNECTION WITH THIS REPORT. ENVIRONMENTAL DATA RESOURCES, INC. SPECIFICALLY DISCLAIMS THE MAKING OF ANY SUCH WARRANTIES, INCLUDING WITHOUT LIMITATION, MERCHANTABILITY OR FITNESS FOR A PARTICULAR USE OR PURPOSE. ALL RISK IS ASSUMED BY THE USER. IN NO EVENT SHALL ENVIRONMENTAL DATA RESOURCES, INC. BE LIABLE TO ANYONE, WHETHER ARISING OUT OF ERRORS OR OMISSIONS, NEGLIGENCE, ACCIDENT OR ANY OTHER CAUSE, FOR ANY LOSS OF DAMAGE, INCLUDING, WITHOUT LIMITATION, SPECIAL, INCIDENTAL CONSEQUENTIAL, OR EXEMPLARY DAMAGES. ANY LIABILITY ON THE PART OF ENVIRONMENTAL DATA RESOURCES, INC. IS STRICTLY LIMITED TO A REFUND OF THE AMOUNT PAID FOR THIS REPORT. Purchaser accepts this Report "AS IS". Any analyses, estimates, ratings, environmental risk levels or risk codes provided in this Report are provided for illustrative purposes only, and are not intended to provide, nor should they be interpreted as providing any facts regarding, or prediction or forecast of, any environmental risk for any property. Only a Phase I Environmental Site Assessment performed by an environmental professional can provide information regarding the environmental risk for any property. Additionally, the information provided in this Report is not to be construed as legal advice.

Copyright 2015 by Environmental Data Resources, Inc. All rights reserved. Reproduction in any media or format, in whole or in part, of any report or map of Environmental Data Resources, Inc., or its affiliates, is prohibited without prior written permission.

EDR and its logos (including Sanborn and Sanborn Map) are trademarks of Environmental Data Resources, Inc. or its affiliates. All other trademarks used herein are the property of their respective owners.

## Sanborn Sheet Thumbnails

This Certified Sanborn Map Report is based upon the following Sanborn Fire Insurance map sheets.



### 1967 Source Sheets



Volume 1, Sheet 3



Volume 1, Sheet 4

### 1950 Source Sheets



Volume 1, Sheet 3



Volume 1, Sheet 4

### 1929 Source Sheets



Volume 1, Sheet 3



Volume 1, Sheet 4

### 1921 Source Sheets

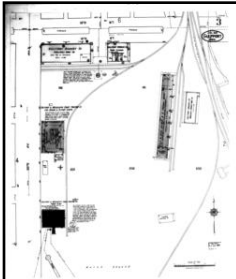

Volume 1, Sheet 3



Volume 1, Sheet 2

**1912 Source Sheets**

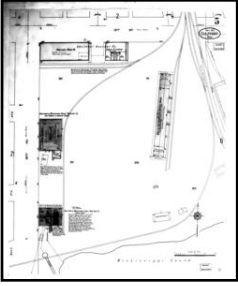

Volume 1, Sheet 5



Volume 1, Sheet 6

# 1967 Certified Sanborn Map

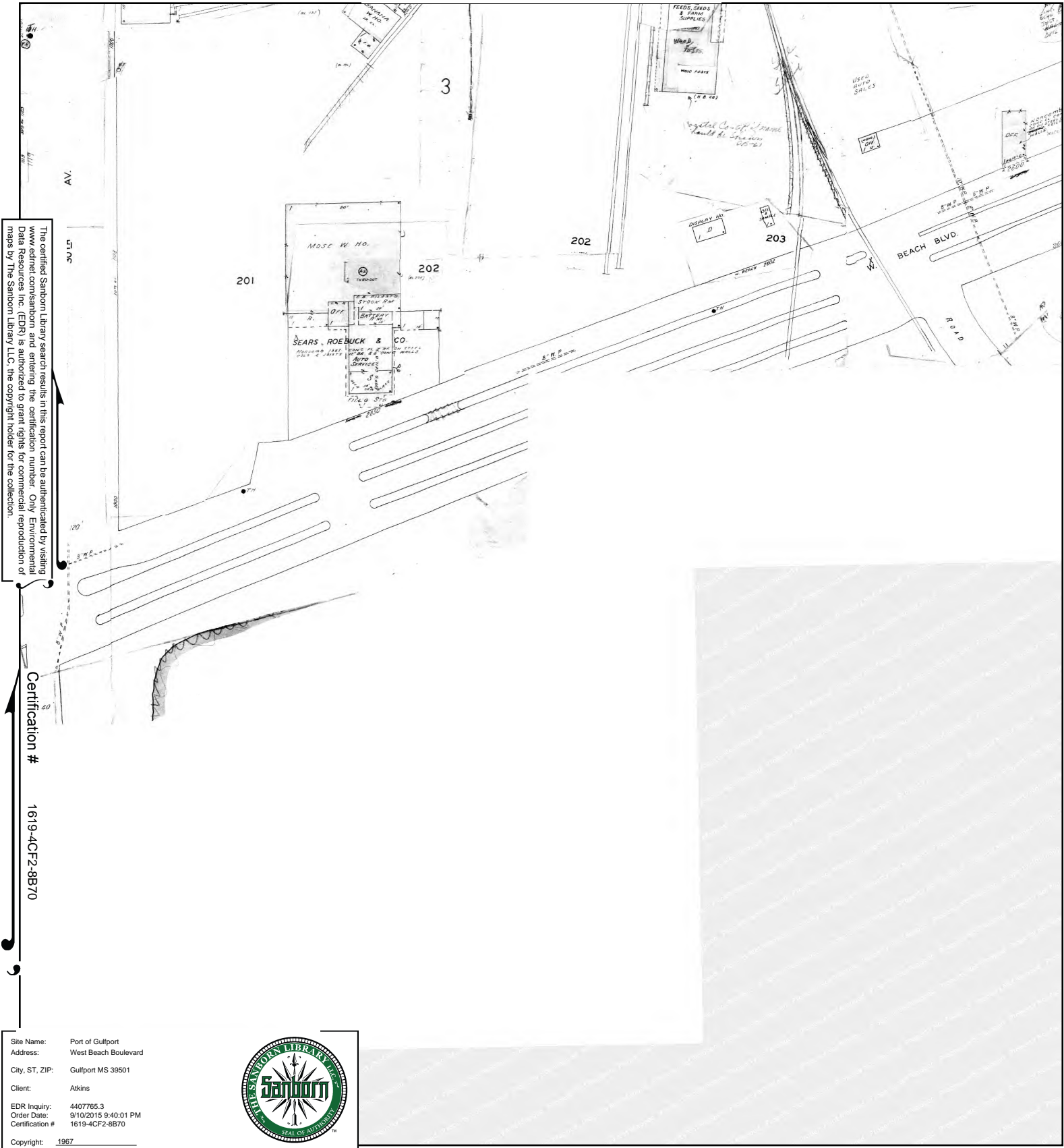

The certified Sanborn Library search results in this report can be authenticated by visiting [www.edrnet.com/sanborn](http://www.edrnet.com/sanborn) and entering the certification number. Only Environmental Data Resources Inc. (EDR) is authorized to grant rights for commercial reproduction of maps by The Sanborn Library LLC, the copyright holder for the collection.

Certification # 1619-4CF2-8B70

Site Name: Port of Gulfport  
 Address: West Beach Boulevard  
 City, ST, ZIP: Gulfport MS 39501  
 Client: Atkins  
 EDR Inquiry: 4407765.3  
 Order Date: 9/10/2015 9:40:01 PM  
 Certification # 1619-4CF2-8B70



This Certified Sanborn Map combines the following sheets. Outlined areas indicate map sheets within the collection.

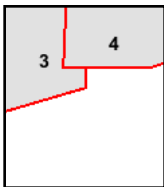
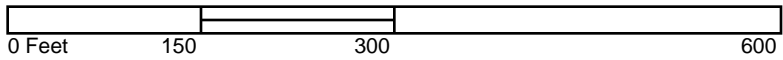

Volume 1, Sheet 3  
 Volume 1, Sheet 4



# 1950 Certified Sanborn Map

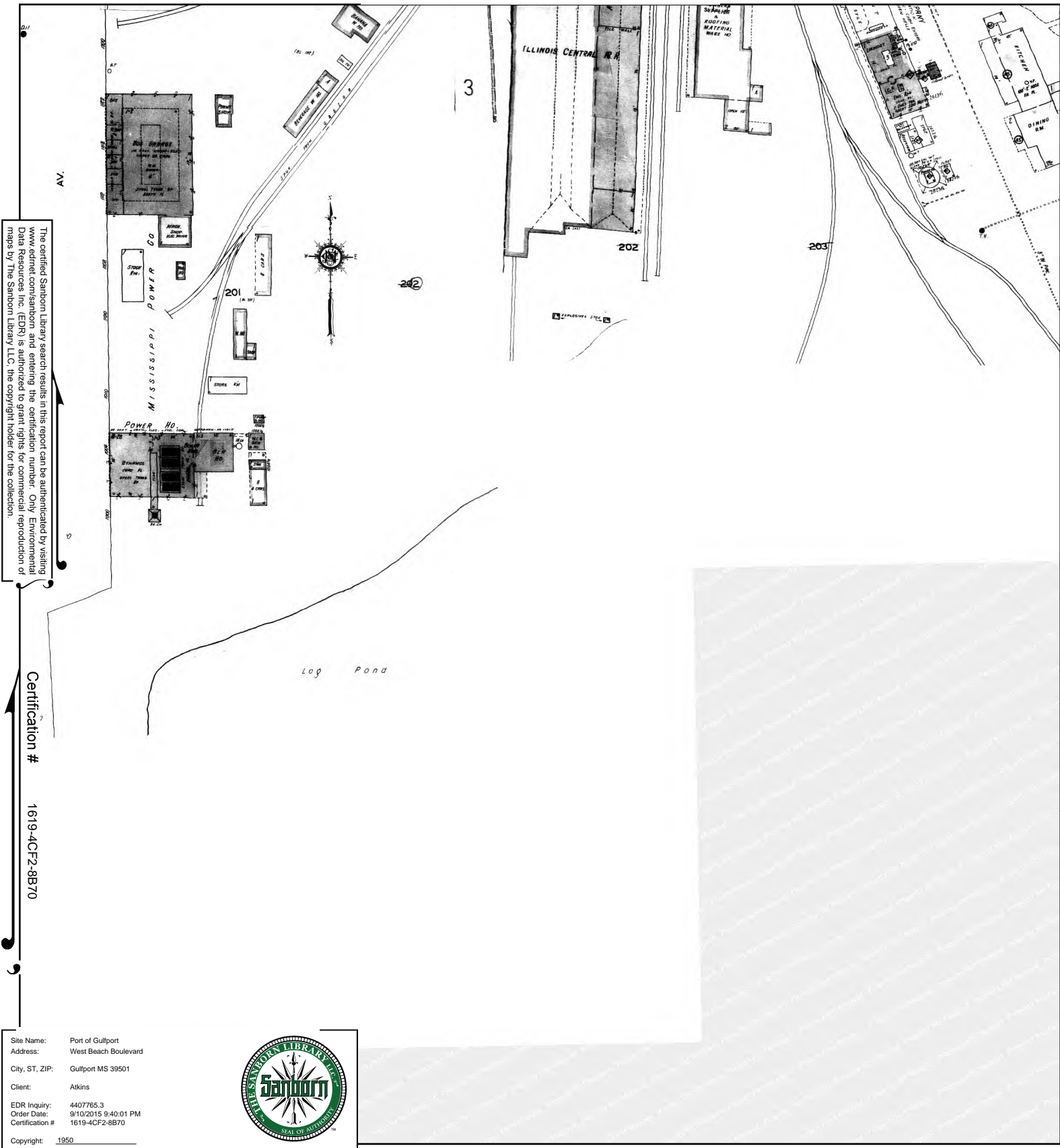

Site Name: Port of Gulfport  
 Address: West Beach Boulevard  
 City, ST, ZIP: Gulfport MS 39501  
 Client: Atkins  
 EDR Inquiry: 4407765.3  
 Order Date: 9/10/2015 9:40:01 PM  
 Certification #: 1619-4CF2-8B70



This Certified Sanborn Map combines the following sheets. Outlined areas indicate map sheets within the collection.

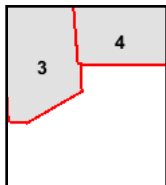
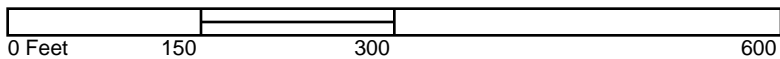

Volume 1, Sheet 3  
 Volume 1, Sheet 4





# 1929 Certified Sanborn Map

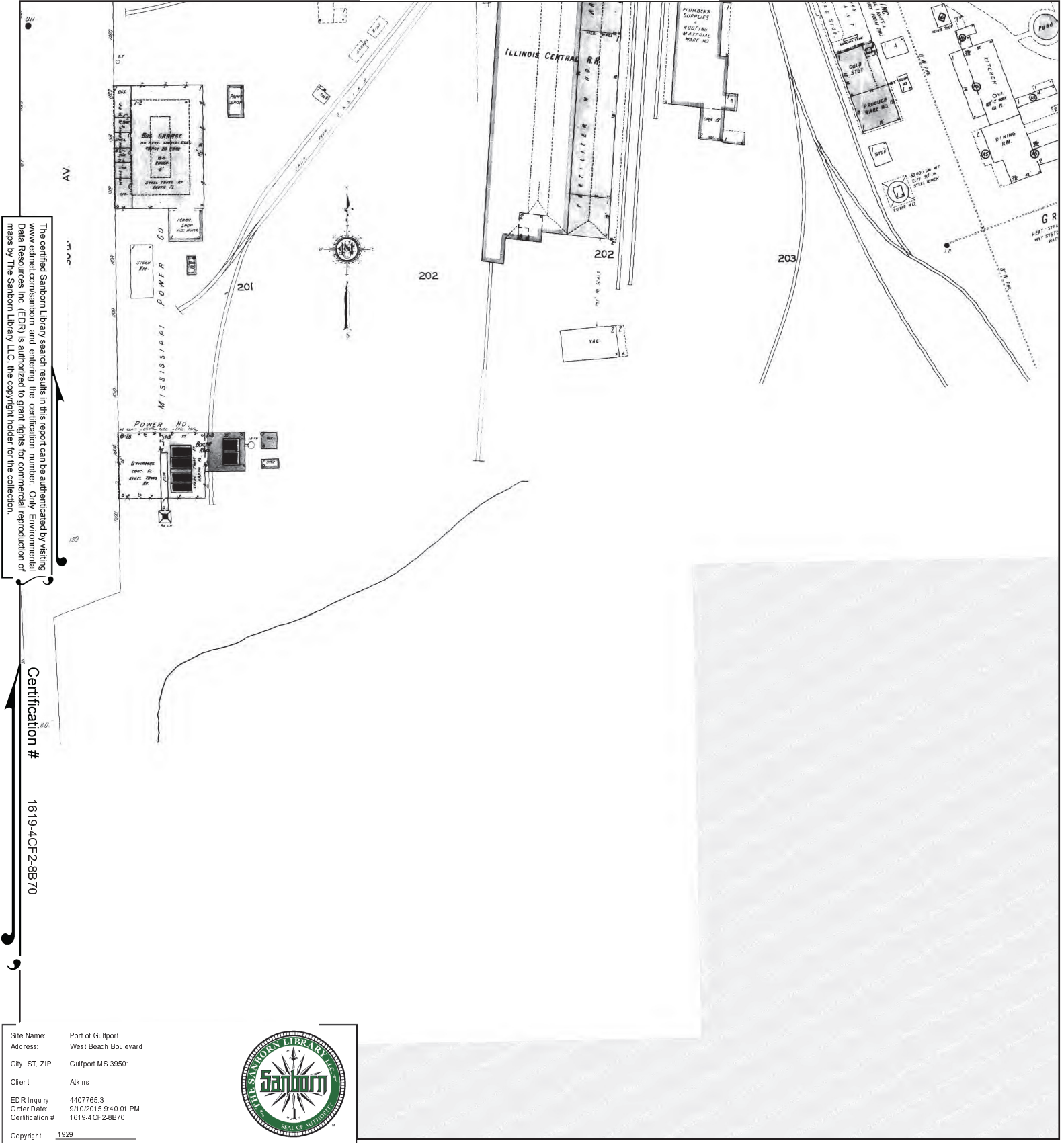

The certified Sanborn Library search results in this report can be authenticated by visiting [www.edrnet.com/sanborn](http://www.edrnet.com/sanborn) and entering the certification number. Only Environmental Data Resources Inc. (EDR) is authorized to grant rights for commercial reproduction of maps by The Sanborn Library LLC, the copyright holder for the collection.

Certification # 1619-4CF2-8870

Site Name: Port of Gulfport  
 Address: West Beach Boulevard  
 City, ST, ZIP: Gulfport MS 39501  
 Client: Atkins  
 EDR Inquiry: 4407765.3  
 Order Date: 9/10/2015 9:40:01 PM  
 Certification #: 1619-4CF2-8870  
 Copyright: 1929



This Certified Sanborn Map combines the following sheets. Outlined areas indicate map sheets within the collection.

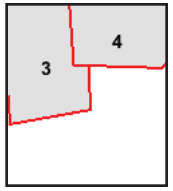
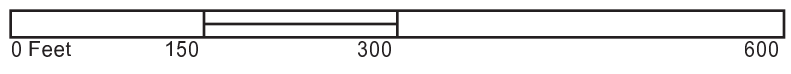

Volume 1, Sheet 3  
 Volume 1, Sheet 4



# 1921 Certified Sanborn Map

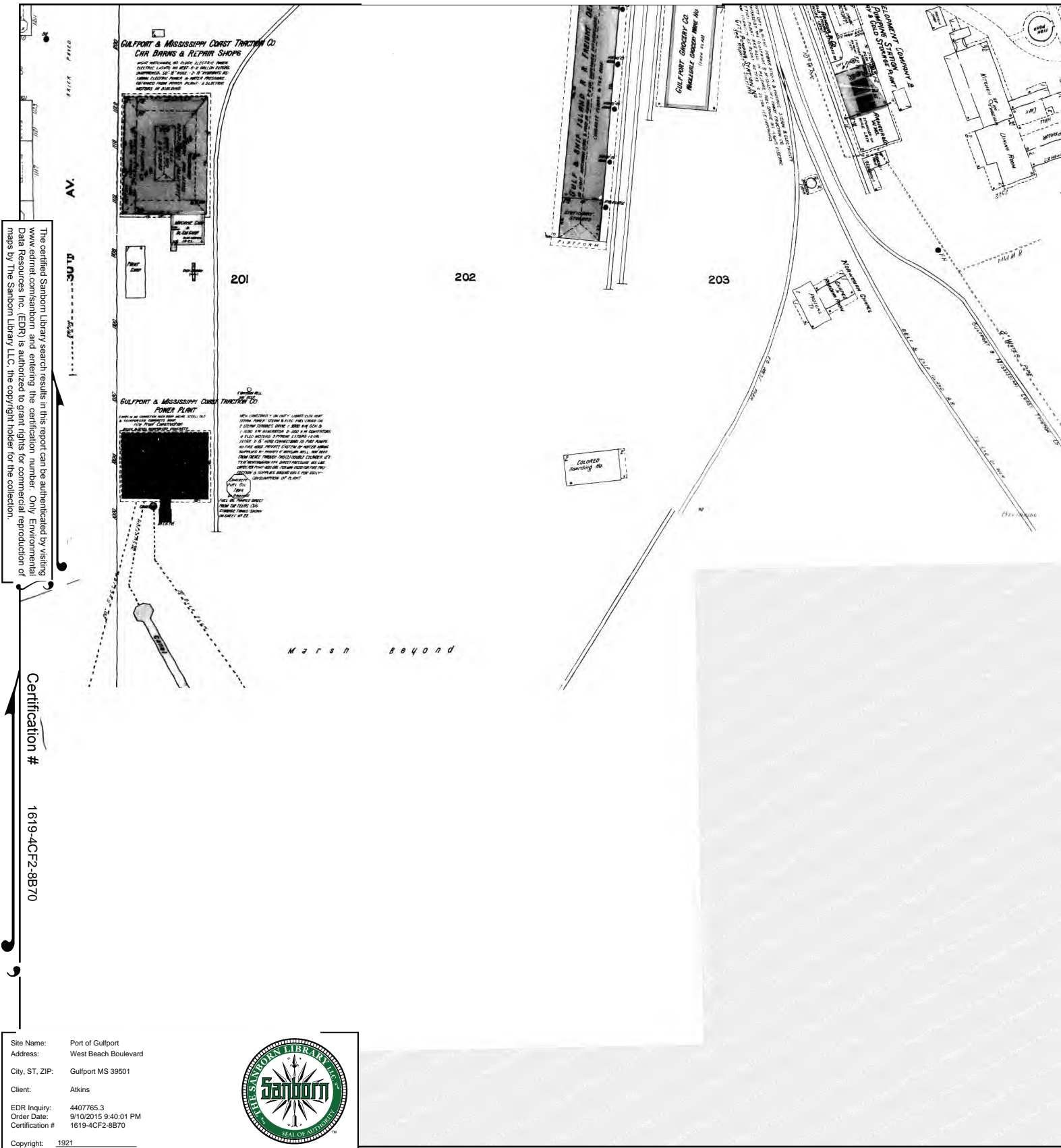

This Certified Sanborn Map combines the following sheets. Outlined areas indicate map sheets within the collection.

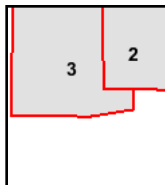
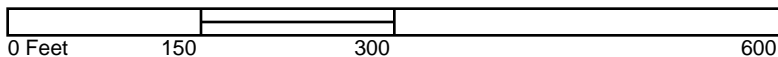

Volume 1, Sheet 3  
Volume 1, Sheet 2





# 1912 Certified Sanborn Map

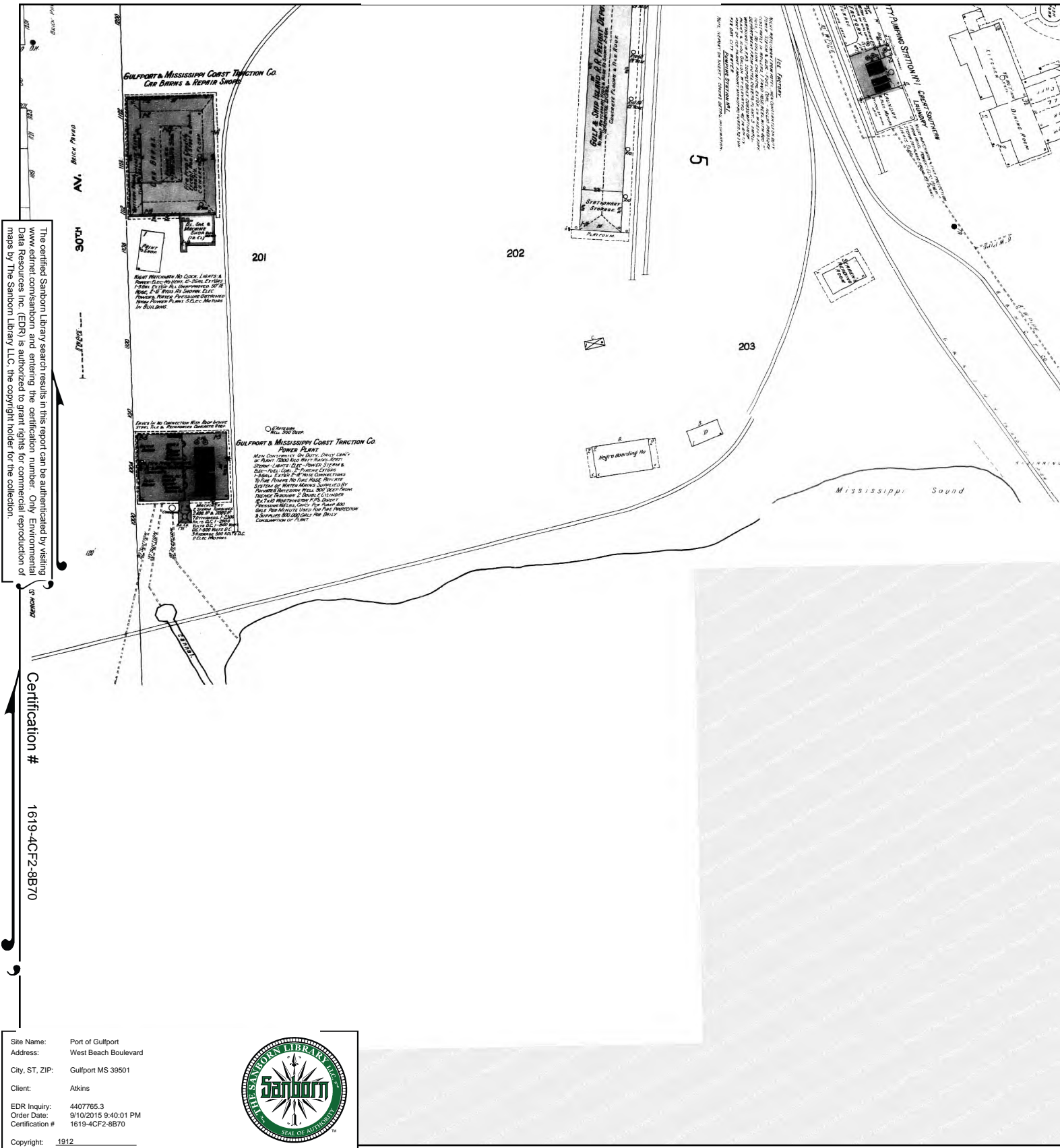

This Certified Sanborn Map combines the following sheets. Outlined areas indicate map sheets within the collection.

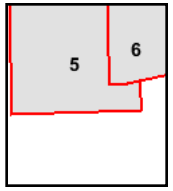
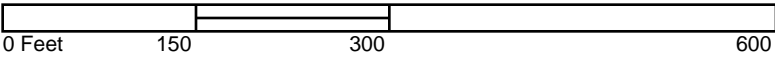

Volume 1, Sheet 5  
 Volume 1, Sheet 6





**Port of Gulfport**

West Beach Blvd

Gulfport, MS 39501

Inquiry Number: 3058388.4

May 03, 2011

# EDR Historical Topographic Map Report

# EDR Historical Topographic Map Report

Environmental Data Resources, Inc.'s (EDR) Historical Topographic Map Report is designed to assist professionals in evaluating potential liability on a target property resulting from past activities. EDR's Historical Topographic Map Report includes a search of a collection of public and private color historical topographic maps, dating back to the early 1900s.

***Thank you for your business.***  
Please contact EDR at 1-800-352-0050  
with any questions or comments.

## Disclaimer - Copyright and Trademark Notice

This Report contains certain information obtained from a variety of public and other sources reasonably available to Environmental Data Resources, Inc. It cannot be concluded from this Report that coverage information for the target and surrounding properties does not exist from other sources. **NO WARRANTY EXPRESSED OR IMPLIED, IS MADE WHATSOEVER IN CONNECTION WITH THIS REPORT. ENVIRONMENTAL DATA RESOURCES, INC. SPECIFICALLY DISCLAIMS THE MAKING OF ANY SUCH WARRANTIES, INCLUDING WITHOUT LIMITATION, MERCHANTABILITY OR FITNESS FOR A PARTICULAR USE OR PURPOSE. ALL RISK IS ASSUMED BY THE USER. IN NO EVENT SHALL ENVIRONMENTAL DATA RESOURCES, INC. BE LIABLE TO ANYONE, WHETHER ARISING OUT OF ERRORS OR OMISSIONS, NEGLIGENCE, ACCIDENT OR ANY OTHER CAUSE, FOR ANY LOSS OF DAMAGE, INCLUDING, WITHOUT LIMITATION, SPECIAL, INCIDENTAL, CONSEQUENTIAL, OR EXEMPLARY DAMAGES. ANY LIABILITY ON THE PART OF ENVIRONMENTAL DATA RESOURCES, INC. IS STRICTLY LIMITED TO A REFUND OF THE AMOUNT PAID FOR THIS REPORT.** Purchaser accepts this Report AS IS. Any analyses, estimates, ratings, environmental risk levels or risk codes provided in this Report are provided for illustrative purposes only, and are not intended to provide, nor should they be interpreted as providing any facts regarding, or prediction or forecast of, any environmental risk for any property. Only a Phase I Environmental Site Assessment performed by an environmental professional can provide information regarding the environmental risk for any property. Additionally, the information provided in this Report is not to be construed as legal advice.

Copyright 2011 by Environmental Data Resources, Inc. All rights reserved. Reproduction in any media or format, in whole or in part, of any report or map of Environmental Data Resources, Inc., or its affiliates, is prohibited without prior written permission.

EDR and its logos (including Sanborn and Sanborn Map) are trademarks of Environmental Data Resources, Inc. or its affiliates. All other trademarks used herein are the property of their respective owners.

# Historical Topographic Map

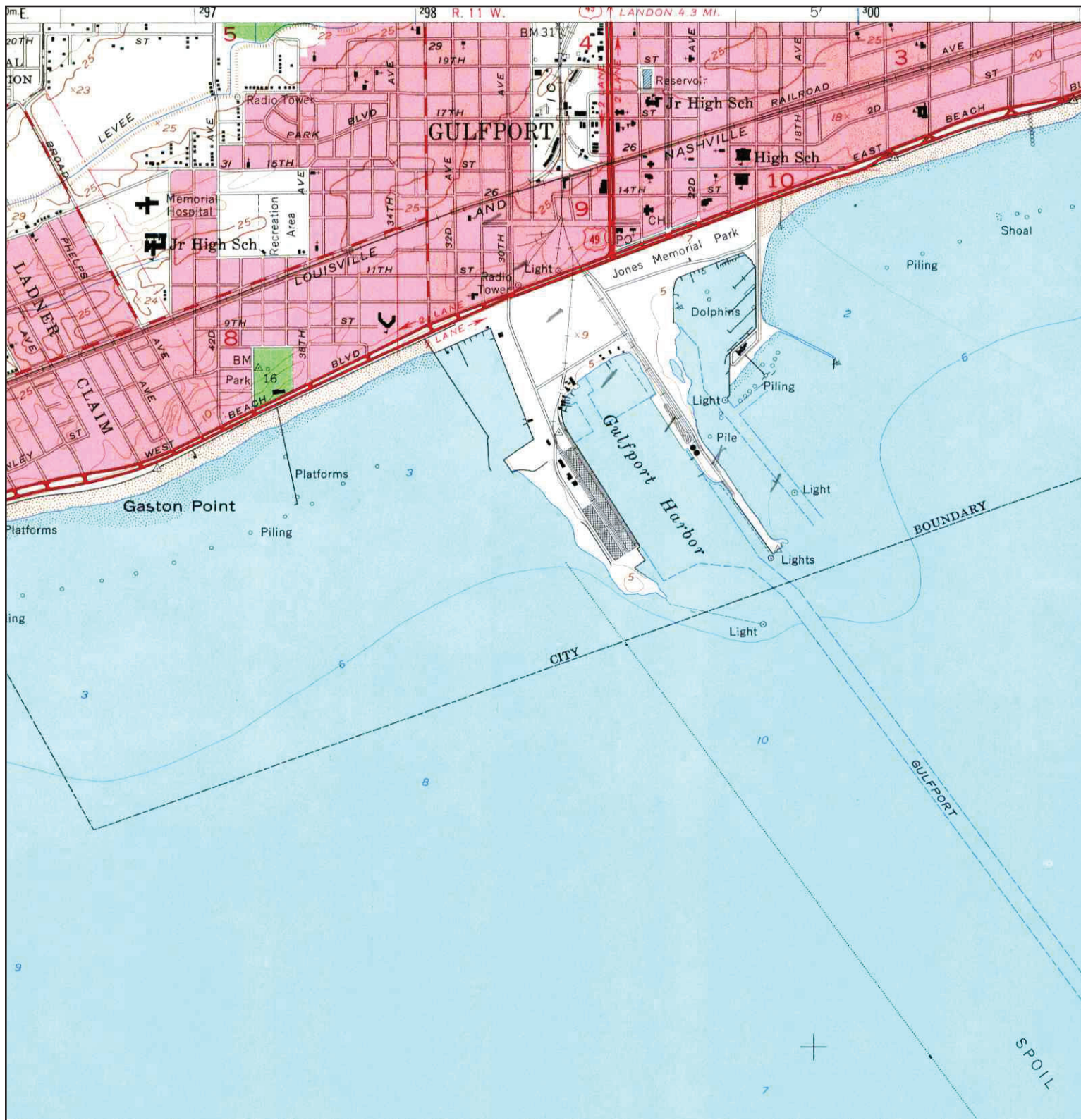

<p>N ↑</p>	<p><b>TARGET QUAD</b>                  NAME: GULFPORT SOUTH                  MAP YEAR: 1954</p>	<p><b>SITE NAME:</b> Port of Gulfport  <b>ADDRESS:</b> West Beach Blvd                  Gulfport, MS 39501  <b>LAT/LONG:</b> 30.3643 / -89.0958</p>	<p><b>CLIENT:</b> North Wind, Inc.  <b>CONTACT:</b> Tony Ruhlman  <b>INQUIRY#:</b> 3058388.4  <b>RESEARCH DATE:</b> 05/03/2011</p>
	<p>SERIES: 7.5                  SCALE: 1:24000</p>		



# Historical Topographic Map

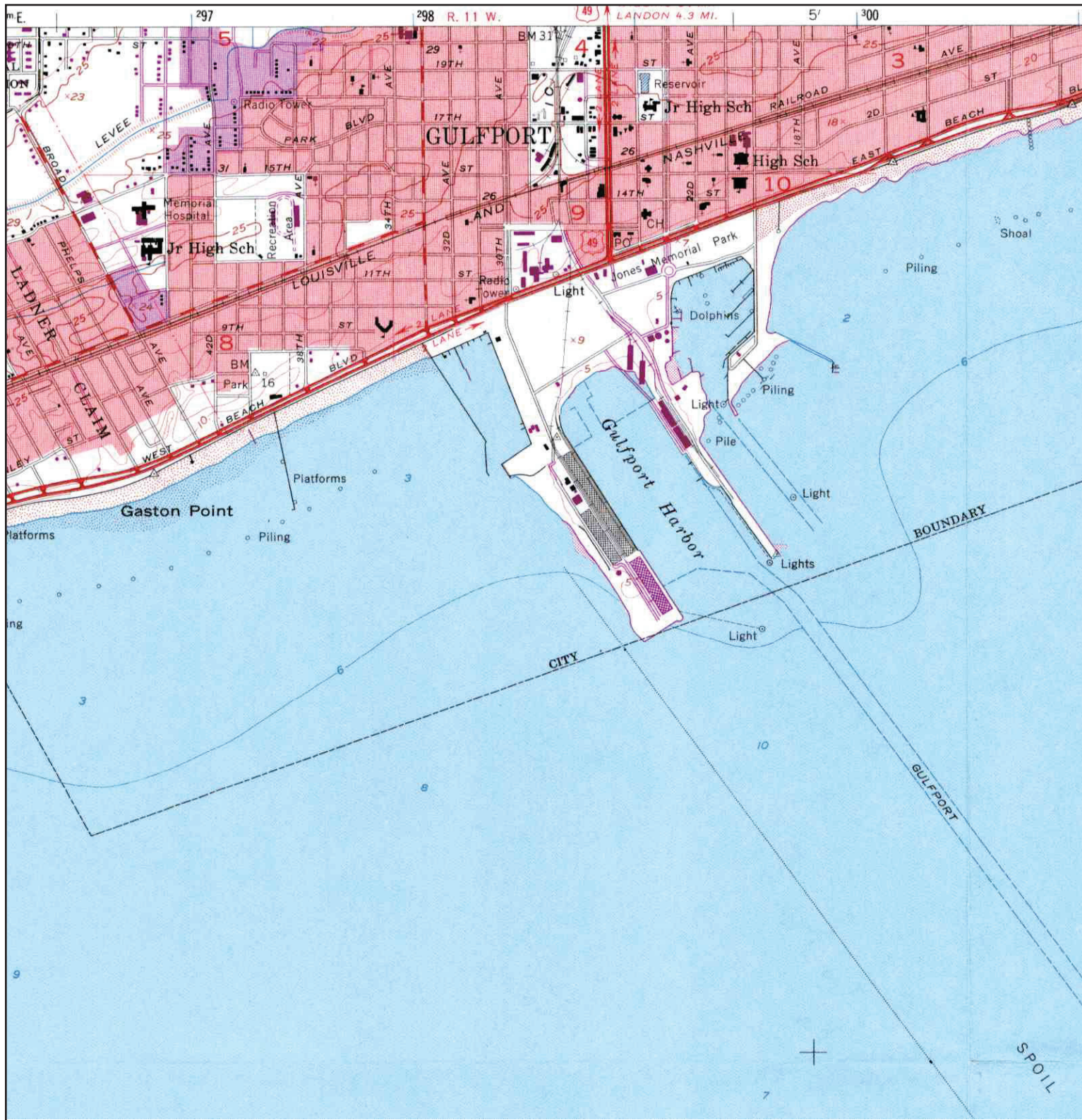

	<b>TARGET QUAD</b>	<b>SITE NAME:</b> Port of Gulfport	<b>CLIENT:</b> North Wind, Inc.
	NAME: GULFPORT SOUTH	<b>ADDRESS:</b> West Beach Blvd	<b>CONTACT:</b> Tony Ruhlman
	MAP YEAR: 1970	Gulfport, MS 39501	<b>INQUIRY#:</b> 3058388.4
	PHOTOREVISED: 1954	<b>LAT/LONG:</b> 30.3643 / -89.0958	<b>RESEARCH DATE:</b> 05/03/2011
	SERIES: 7.5		
	SCALE: 1:24000		



# Historical Topographic Map

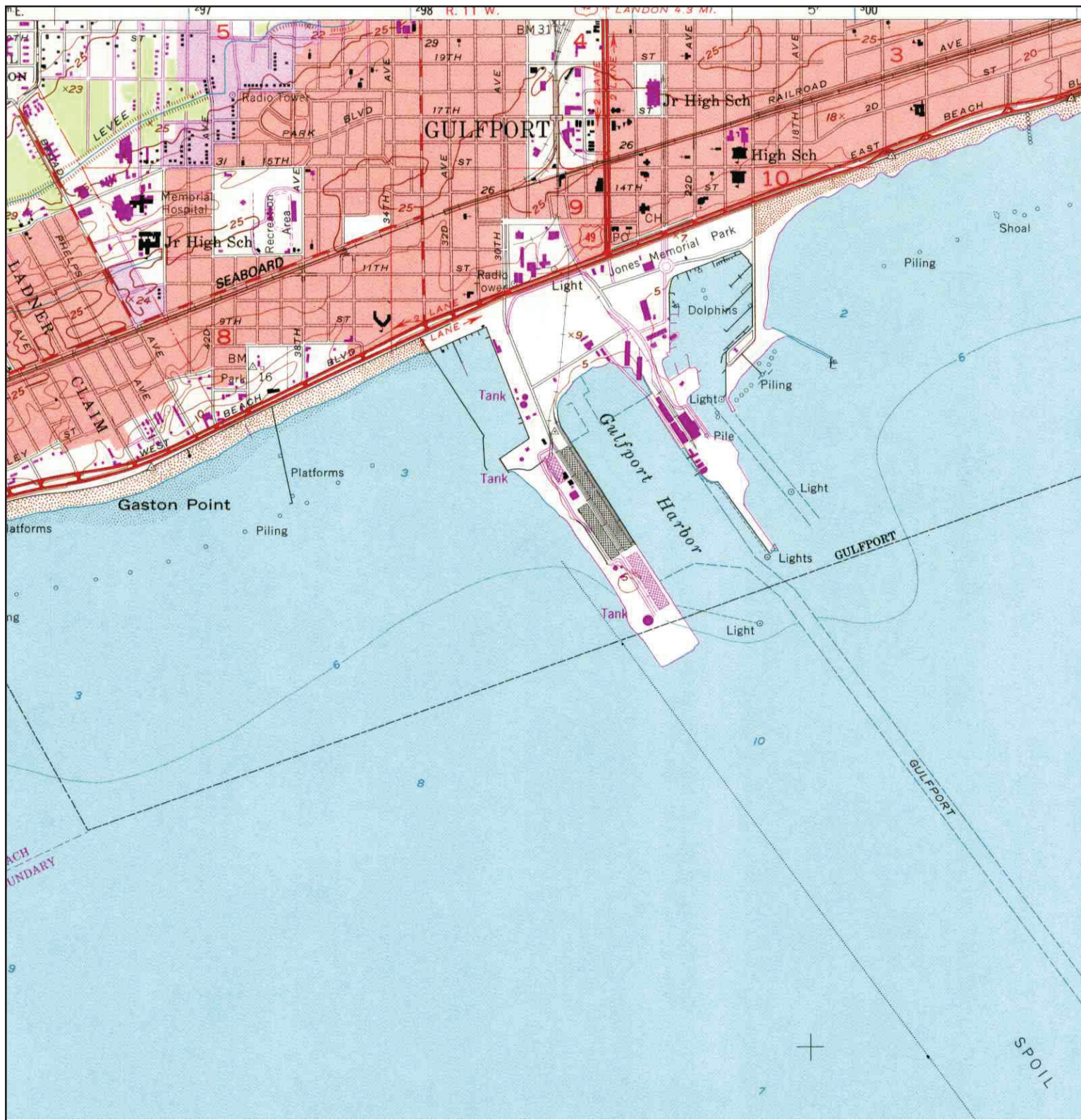

	<b>TARGET QUAD</b>	<b>SITE NAME:</b> Port of Gulfport	<b>CLIENT:</b> North Wind, Inc.
	NAME: GULFPORT SOUTH	<b>ADDRESS:</b> West Beach Blvd	<b>CONTACT:</b> Tony Ruhlman
	MAP YEAR: 1985	Gulfport, MS 39501	<b>INQUIRY#:</b> 3058388.4
	PHOTOREVISED: 1954	<b>LAT/LONG:</b> 30.3643 / -89.0958	<b>RESEARCH DATE:</b> 05/03/2011
	SERIES: 7.5		
	SCALE: 1:24000		



# Historical Topographic Map

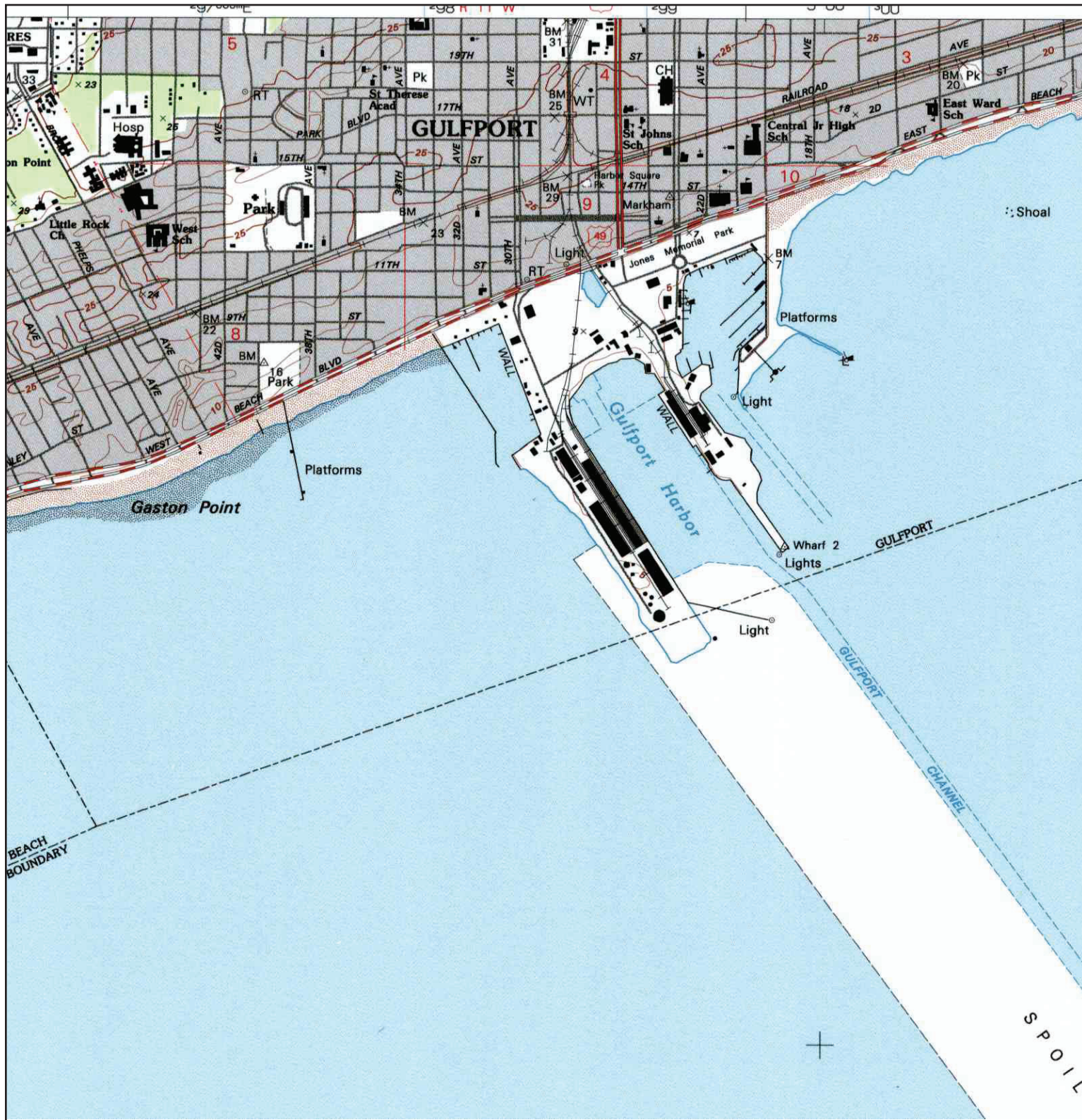

<b>N</b> 	<b>TARGET QUAD</b>	<b>SITE NAME:</b> Port of Gulfport	<b>CLIENT:</b> North Wind, Inc.
	<b>NAME:</b> GULFPORT SOUTH	<b>ADDRESS:</b> West Beach Blvd	<b>CONTACT:</b> Tony Ruhlman
	<b>MAP YEAR:</b> 1994	<b>LAT/LONG:</b> 30.3643 / -89.0958	<b>INQUIRY#:</b> 3058388.4
	<b>SERIES:</b> 7.5		<b>RESEARCH DATE:</b> 05/03/2011
	<b>SCALE:</b> 1:24000		



**Port of Gulfport**

West Beach Boulevard

Gulfport, MS 39501

Inquiry Number: 4407765.5

September 11, 2015

## The EDR Aerial Photo Decade Package



6 Armstrong Road, 4th Floor  
Shelton, Connecticut 06484  
Toll Free: 800.352.0050  
[www.edrnet.com](http://www.edrnet.com)



# EDR Aerial Photo Decade Package

Environmental Data Resources, Inc. (EDR) Aerial Photo Decade Package is a screening tool designed to assist environmental professionals in evaluating potential liability on a target property resulting from past activities. EDR's professional researchers provide digitally reproduced historical aerial photographs, and when available, provide one photo per decade.

**When delivered electronically by EDR, the aerial photo images included with this report are for ONE TIME USE ONLY. Further reproduction of these aerial photo images is prohibited without permission from EDR. For more information contact your EDR Account Executive.**

***Thank you for your business.***  
Please contact EDR at 1-800-352-0050  
with any questions or comments.

## **Disclaimer - Copyright and Trademark Notice**

This Report contains certain information obtained from a variety of public and other sources reasonably available to Environmental Data Resources, Inc. It cannot be concluded from this Report that coverage information for the target and surrounding properties does not exist from other sources. **NO WARRANTY EXPRESSED OR IMPLIED, IS MADE WHATSOEVER IN CONNECTION WITH THIS REPORT. ENVIRONMENTAL DATA RESOURCES, INC. SPECIFICALLY DISCLAIMS THE MAKING OF ANY SUCH WARRANTIES, INCLUDING WITHOUT LIMITATION, MERCHANTABILITY OR FITNESS FOR A PARTICULAR USE OR PURPOSE. ALL RISK IS ASSUMED BY THE USER. IN NO EVENT SHALL ENVIRONMENTAL DATA RESOURCES, INC. BE LIABLE TO ANYONE, WHETHER ARISING OUT OF ERRORS OR OMISSIONS, NEGLIGENCE, ACCIDENT OR ANY OTHER CAUSE, FOR ANY LOSS OF DAMAGE, INCLUDING, WITHOUT LIMITATION, SPECIAL, INCIDENTAL, CONSEQUENTIAL, OR EXEMPLARY DAMAGES. ANY LIABILITY ON THE PART OF ENVIRONMENTAL DATA RESOURCES, INC. IS STRICTLY LIMITED TO A REFUND OF THE AMOUNT PAID FOR THIS REPORT.** Purchaser accepts this Report AS IS. Any analyses, estimates, ratings, environmental risk levels or risk codes provided in this Report are provided for illustrative purposes only, and are not intended to provide, nor should they be interpreted as providing any facts regarding, or prediction or forecast of, any environmental risk for any property. Only a Phase I Environmental Site Assessment performed by an environmental professional can provide information regarding the environmental risk for any property. Additionally, the information provided in this Report is not to be construed as legal advice.

Copyright 2015 by Environmental Data Resources, Inc. All rights reserved. Reproduction in any media or format, in whole or in part, of any report or map of Environmental Data Resources, Inc., or its affiliates, is prohibited without prior written permission.

EDR and its logos (including Sanborn and Sanborn Map) are trademarks of Environmental Data Resources, Inc. or its affiliates. All other trademarks used herein are the property of their respective owners.

**Date EDR Searched Historical Sources:**

Aerial Photography September 11, 2015

**Target Property:**

West Beach Boulevard

Gulfport, MS 39501

<u><i>Year</i></u>	<u><i>Scale</i></u>	<u><i>Details</i></u>	<u><i>Source</i></u>
1952	Aerial Photograph. Scale: 1"=500'	Flight Date: May 12, 1952	USGS
1975	Aerial Photograph. Scale: 1"=500'	Flight Date: October 20, 1975	EDR
1985	Aerial Photograph. Scale: 1"=500'	Flight Date: October 05, 1985	USGS
1987	Aerial Photograph. Scale: 1"=500'	Flight Date: November 18, 1987	USGS
1992	Aerial Photograph. Scale: 1"=500'	DOQQ - acquisition dates: February 19, 1992	USGS/DOQQ
1996	Aerial Photograph. Scale: 1"=750'	Flight Date: March 02, 1996	EDR
2005	Aerial Photograph. Scale: 1"=500'	Flight Year: 2005	USDA/NAIP
2007	Aerial Photograph. Scale: 1"=500'	Flight Year: 2007	USDA/NAIP
2009	Aerial Photograph. Scale: 1"=500'	Flight Year: 2009	USDA/NAIP
2010	Aerial Photograph. Scale: 1"=500'	Flight Year: 2010	USDA/NAIP
2012	Aerial Photograph. Scale: 1"=500'	Flight Year: 2012	USDA/NAIP



**INQUIRY #:** 4407765.5

**YEAR:** 1952

|—————| = 500'





**INQUIRY #:** 4407765.5

**YEAR:** 1975

| = 500'







INQUIRY #: 4407765.5

YEAR: 1985

| = 500'







**INQUIRY #:** 4407765.5

**YEAR:** 1987

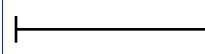
 = 500'





INQUIRY #: 4407765.5

YEAR: 1992

| = 500'





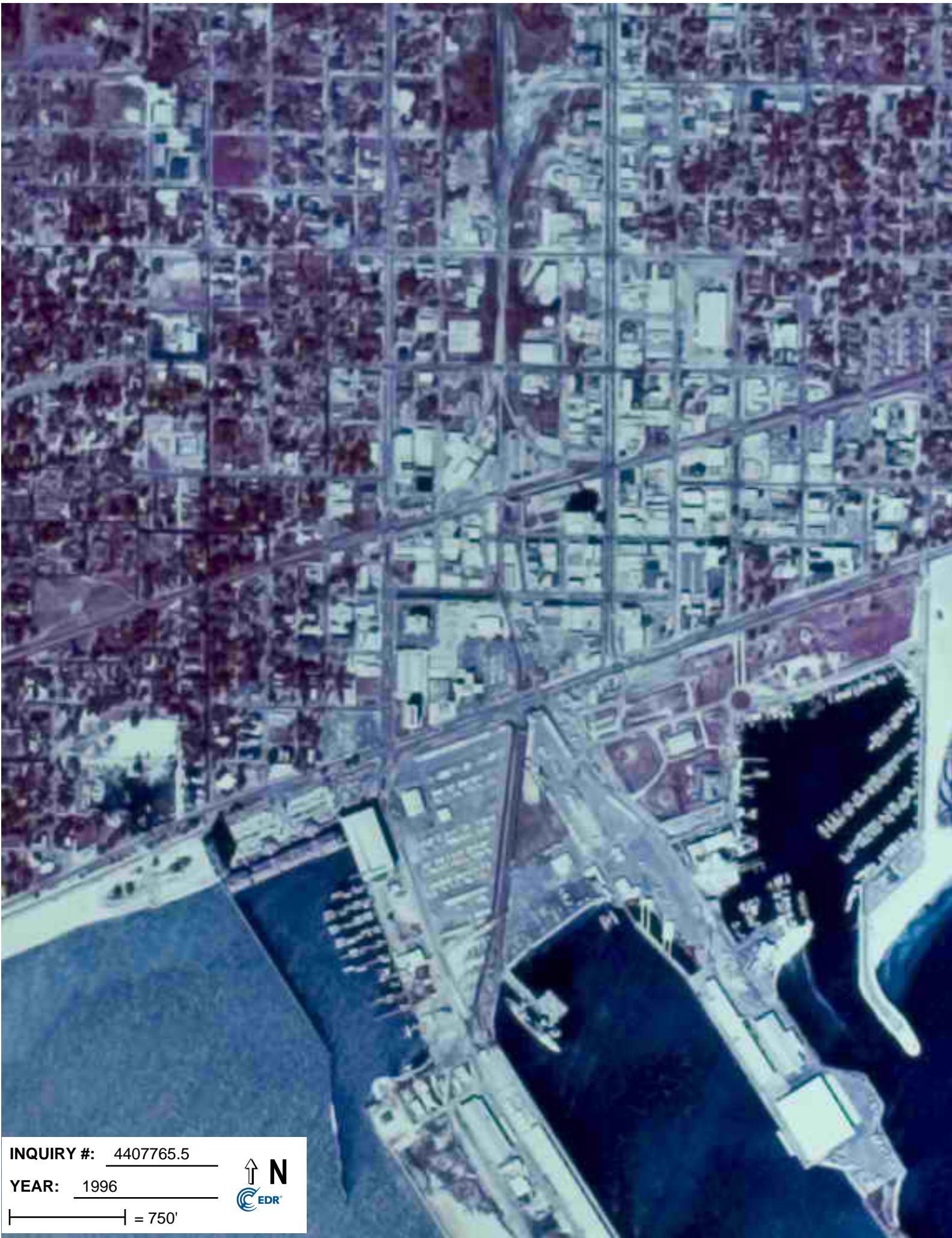

INQUIRY #: 4407765.5

YEAR: 1996

| = 750'







**INQUIRY #:** 4407765.5

**YEAR:** 2005

**|** = 500'







INQUIRY #: 4407765.5

YEAR: 2007

— = 500'







INQUIRY #: 4407765.5

YEAR: 2009

| = 500'







**INQUIRY #:** 4407765.5

**YEAR:** 2010

 = 500'







**INQUIRY #:** 4407765.5

**YEAR:** 2012

**|** = 500'





**Port of Gulfport**

West Beach Boulevard  
Gulfport, MS 39501

Inquiry Number: 4407765.2s  
September 10, 2015

# The EDR Radius Map™ Report with GeoCheck®

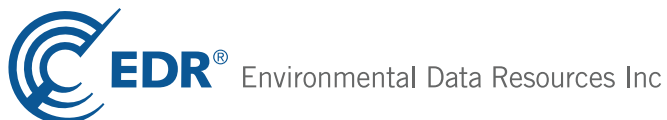

6 Armstrong Road, 4th floor  
Shelton, CT 06484  
Toll Free: 800.352.0050  
[www.edrnet.com](http://www.edrnet.com)

# TABLE OF CONTENTS

<u>SECTION</u>	<u>PAGE</u>
Executive Summary .....	ES1
Overview Map .....	2
Detail Map .....	3
Map Findings Summary .....	4
Map Findings .....	7
Orphan Summary .....	163
Government Records Searched/Data Currency Tracking .....	GR-1
 <b><u>GEOCHECK ADDENDUM</u></b>	
Physical Setting Source Addendum .....	A-1
Physical Setting Source Summary .....	A-2
Physical Setting SSURGO Soil Map .....	A-5
Physical Setting Source Map .....	A-11
Physical Setting Source Map Findings .....	A-13
Physical Setting Source Records Searched .....	PSGR-1

***Thank you for your business.***  
Please contact EDR at 1-800-352-0050  
with any questions or comments.

### Disclaimer - Copyright and Trademark Notice

This Report contains certain information obtained from a variety of public and other sources reasonably available to Environmental Data Resources, Inc. It cannot be concluded from this Report that coverage information for the target and surrounding properties does not exist from other sources. **NO WARRANTY EXPRESSED OR IMPLIED, IS MADE WHATSOEVER IN CONNECTION WITH THIS REPORT. ENVIRONMENTAL DATA RESOURCES, INC. SPECIFICALLY DISCLAIMS THE MAKING OF ANY SUCH WARRANTIES, INCLUDING WITHOUT LIMITATION, MERCHANTABILITY OR FITNESS FOR A PARTICULAR USE OR PURPOSE. ALL RISK IS ASSUMED BY THE USER. IN NO EVENT SHALL ENVIRONMENTAL DATA RESOURCES, INC. BE LIABLE TO ANYONE, WHETHER ARISING OUT OF ERRORS OR OMISSIONS, NEGLIGENCE, ACCIDENT OR ANY OTHER CAUSE, FOR ANY LOSS OF DAMAGE, INCLUDING, WITHOUT LIMITATION, SPECIAL, INCIDENTAL, CONSEQUENTIAL, OR EXEMPLARY DAMAGES. ANY LIABILITY ON THE PART OF ENVIRONMENTAL DATA RESOURCES, INC. IS STRICTLY LIMITED TO A REFUND OF THE AMOUNT PAID FOR THIS REPORT.** Purchaser accepts this Report "AS IS". Any analyses, estimates, ratings, environmental risk levels or risk codes provided in this Report are provided for illustrative purposes only, and are not intended to provide, nor should they be interpreted as providing any facts regarding, or prediction or forecast of, any environmental risk for any property. Only a Phase I Environmental Site Assessment performed by an environmental professional can provide information regarding the environmental risk for any property. Additionally, the information provided in this Report is not to be construed as legal advice.

Copyright 2015 by Environmental Data Resources, Inc. All rights reserved. Reproduction in any media or format, in whole or in part, of any report or map of Environmental Data Resources, Inc., or its affiliates, is prohibited without prior written permission.

EDR and its logos (including Sanborn and Sanborn Map) are trademarks of Environmental Data Resources, Inc. or its affiliates. All other trademarks used herein are the property of their respective owners.



## EXECUTIVE SUMMARY

A search of available environmental records was conducted by Environmental Data Resources, Inc (EDR). The report was designed to assist parties seeking to meet the search requirements of EPA's Standards and Practices for All Appropriate Inquiries (40 CFR Part 312), the ASTM Standard Practice for Environmental Site Assessments (E 1527-13) or custom requirements developed for the evaluation of environmental risk associated with a parcel of real estate.

### TARGET PROPERTY INFORMATION

#### ADDRESS

WEST BEACH BOULEVARD  
GULFPORT, MS 39501

#### COORDINATES

Latitude (North): 30.3643000 - 30° 21' 51.48"  
Longitude (West): 89.0958000 - 89° 5' 44.88"  
Universal Transverse Mercator: Zone 16  
UTM X (Meters): 298581.1  
UTM Y (Meters): 3360835.0  
Elevation: 10 ft. above sea level

### USGS TOPOGRAPHIC MAP ASSOCIATED WITH TARGET PROPERTY

Target Property Map: 5637359 GULFPORT SOUTH, MS  
Version Date: 2012

North Map: 5637355 GULFPORT NORTH, MS  
Version Date: 2012

Southwest Map: 5637373 PASS CHRISTIAN, MS  
Version Date: 2012

Northwest Map: 5637357 GULFPORT NW, MS  
Version Date: 2012

### AERIAL PHOTOGRAPHY IN THIS REPORT

Portions of Photo from: 20120909  
Source: USDA

MAPPED SITES SUMMARY

Target Property Address:  
 WEST BEACH BOULEVARD  
 GULFPORT, MS 39501

Click on Map ID to see full detail.

MAP ID	SITE NAME	ADDRESS	DATABASE ACRONYMS	RELATIVE ELEVATION	DIST (ft. & mi.) DIRECTION
Reg	NAVAL CONSTRUCTION B		DOD	Same	5245, 0.993, NNW
A1	SEARS FACILITY #7456		SHWS	Higher	173, 0.033, ENE
A2	SEARS #7456	2818 WEST BEACH BOUL	UST	Higher	180, 0.034, NNW
A3	SEARS NUMBER 7456	2818 WEST BEACH BOUL	FINDS	Higher	180, 0.034, NNW
A4		877 COPA BLVD	ERNS	Higher	348, 0.066, ENE
B5		1000 30TH AVE	ERNS	Higher	534, 0.101, West
6	OLD COPA CASINO	777 COPA BOULEVARD	FINDS	Lower	629, 0.119, SSE
C7	JR. FOOD MART #39	2605 WEST BEACH BLVD	RGA LUST	Higher	634, 0.120, ENE
C8	JR FOOD MART #39	2605 WEST BEACH BOUL	RGA LUST	Higher	634, 0.120, ENE
C9	JR FOOD MART #39	2605 WEST BEACH BLVD	RGA LUST	Higher	634, 0.120, ENE
C10	JR. FOOD MART 39	2605 WEST BEACH BLVD	RGA LUST	Higher	634, 0.120, ENE
C11	JR FOOD MART #39	2605 WEST BEACH BOUL	LUST, UST	Higher	634, 0.120, ENE
C12	JR FOOD MART NUMBER	2605 WEST BEACH BOUL	FINDS	Higher	634, 0.120, ENE
B13	MS STATE PORT AUTHOR	30TH AVE SOUTH OF HI	LUST, UST	Higher	645, 0.122, WNW
B14	CHIQUITA BRANDS INC	HIGHWAY 90 & 30TH AV	RCRA-CESQG, UST, ICIS, FINDS	Higher	645, 0.122, WNW
C15	FORMER BARON #75	2501 WEST BEACH BOUL	LUST, UST	Higher	709, 0.134, ENE
C16	BARON #75	2501 WEST BEACH BOUL	RGA LUST	Higher	709, 0.134, ENE
C17	FORMER BARON #75	2501 WEST BEACH BOUL	RGA LUST	Higher	709, 0.134, ENE
B18	MS POWER COMPANY GEN	2992 WEST BEACH BOUL	UST	Higher	718, 0.136, West
B19	MS POWER COMPANY GEN	2992 WEST BEACH BOUL	FINDS	Higher	718, 0.136, West
B20	SUPERIOR CHRYSLER-PL	3002 WEST BEACH BOUL	RCRA NonGen / NLR	Higher	750, 0.142, West
B21	SUPERIOR CHRYSLER PL	3002 WEST BEACH BOUL	FINDS	Higher	750, 0.142, West
D22	FAST TRAC #23	1119 30TH AVENUE	RGA LUST	Higher	765, 0.145, NW
D23	30TH AVENUE CHEVRON	1119 30TH AVENUE	RGA LUST	Higher	765, 0.145, NW
D24	30TH AVE CHEVRON FOO	1119 30TH AVENUE	RGA LUST	Higher	765, 0.145, NW
D25	SWIFTY SERVE #527	1119 30TH AVENUE	RGA LUST	Higher	765, 0.145, NW
D26	FAST MART #23	1119 30TH AVENUE	LUST, UST	Higher	765, 0.145, NW
D27		1119 30TH AVE	EDR US Hist Auto Stat	Higher	765, 0.145, NW
D28	FAST TRAC NUMBER 23	1119 30TH AVENUE	FINDS	Higher	765, 0.145, NW
D29	P T DELI # 1	3000 12TH STREET	RGA LUST	Higher	890, 0.169, NW
D30	P T DELI #1	3000 12TH STREET	LUST, UST	Higher	890, 0.169, NW
D31	EARTH CONSULTING GRO	3000 12TH STREET	FINDS	Higher	890, 0.169, NW
D32	P T DELI #1	3000 12TH STREET	RGA LUST	Higher	890, 0.169, NW
D33	COASTAL ENERGY CO OF	3000 12TH STREET	RGA LUST	Higher	890, 0.169, NW
D34		1223 30TH AVE	EDR US Hist Auto Stat	Higher	948, 0.180, NW
E35	COLONIAL TRAILWAYS B	2805 13TH STREET	LUST, UST	Higher	992, 0.188, North
E36	COLONIAL TRAILWAYS B	2805 13TH STREET	FINDS	Higher	992, 0.188, North
E37	COLONIAL TRAILWAYS B	2805 13TH STREET	RGA LUST	Higher	992, 0.188, North
E38	MOSERS AUTO SERVICE	2800 13TH STREET	RCRA-CESQG	Higher	1063, 0.201, North

MAPPED SITES SUMMARY

Target Property Address:  
WEST BEACH BOULEVARD  
GULFPORT, MS 39501

Click on Map ID to see full detail.

MAP ID	SITE NAME	ADDRESS	DATABASE ACRONYMS	RELATIVE ELEVATION	DIST (ft. & mi.) DIRECTION
E39	K AND K PERFORMANCE	2800 13TH STREET	FINDS	Higher	1063, 0.201, North
E40	K & K PERFORMANCE SH	2800 13TH ST	RCRA-CESQG	Higher	1063, 0.201, North
E41	MOSERS AUTO SERVICE	2800 13TH STREET	FINDS	Higher	1063, 0.201, North
E42	1325 28TH AVENUE	1325 28TH AVENUE	FINDS	Higher	1153, 0.218, North
F43	ASTRO LINCOLN-MERCUR	2617 13TH STREET	RCRA-CESQG	Higher	1155, 0.219, NNE
F44	FORD DEALERSHIP	2617 13TH STREET	UST	Higher	1155, 0.219, NNE
F45	ASTRO LINCOLN MERCUR	2617 13TH STREET	FINDS	Higher	1155, 0.219, NNE
G46		PO BOX 1689 ON EAST	ERNS	Higher	1207, 0.229, NE
G47	WHITNEY NATIONAL BAN	1300 25TH AVENUE	FINDS	Higher	1215, 0.230, NE
H48	AMERIPRIDE SERVICES	1329 29TH AVENUE	FINDS	Higher	1228, 0.233, NNW
H49	AMERIPRIDE SERVICES	1329 29TH AVENUE	US BROWNFIELDS	Higher	1228, 0.233, NNW
I50	MACS QUICK STOP	1301 30TH AVENUE	FINDS	Higher	1233, 0.234, NNW
I51	MAC'S QUICK STOP	1301 30TH AVENUE	RGA LUST	Higher	1233, 0.234, NNW
I52	MAC'S QUICK STOP	1301 30TH AVENUE	LUST, UST	Higher	1233, 0.234, NNW
G53	BALCH & BINGHAM, LLP	1314 25TH STREET	ASBESTOS	Higher	1236, 0.234, NE
I54	AMERIPRIDE LINEN & A		SHWS, VCP	Higher	1255, 0.238, NNW
I55	AMERIPRIDE LINEN AND	1316 30TH AVENUE	FINDS	Higher	1261, 0.239, NNW
I56	AMERICAN LINEN	1316 30TH AVENUE	RCRA-CESQG	Higher	1261, 0.239, NNW
I57	AMERICAN LINEN SUPPL	1316 30TH AVENUE	UST	Higher	1261, 0.239, NNW
H58	HIGH TECH SERVICES		SHWS	Higher	1282, 0.243, NNW
J59	BARRETTS CLEANERS		SHWS	Higher	1310, 0.248, NNE
F60	MDOT - AMERIPRIDE LI		SHWS	Higher	1311, 0.248, NNE
F61		POB 40	ERNS	Higher	1326, 0.251, NE
J62	FORMER BARRETT CLEAN	2711 14TH STREET	US BROWNFIELDS	Higher	1425, 0.270, North
J63	FORMER BARRETT CLEAN	2711 14TH STREET	FINDS	Higher	1425, 0.270, North
J64	JACK BARRETTS MODERN	2711 14TH STREET	FINDS	Higher	1425, 0.270, North
J65		2711 14TH ST	EDR US Hist Cleaners	Higher	1425, 0.270, North
K66	MDOT HARRISON COUNTY	1401 28TH AVENUE	ASBESTOS	Higher	1429, 0.271, North
K67	MDOT - LAZANA PROPER		SHWS	Higher	1470, 0.278, North
L68	WHITNEY NATIONAL BAN	1300 25TH AVENUE	UST	Higher	1472, 0.279, NE
L69	FIRESTONE STORE #050	1420 25TH AVENUE	RGA LUST	Higher	1481, 0.280, NE
L70	FIRESTONE	1420 25TH AVENUE	FINDS	Higher	1481, 0.280, NE
L71	FIRESTONE STORE #050	1420 25TH AVENUE	LUST, UST	Higher	1481, 0.280, NE
L72	FIRESTONE STORES	1420 25TH AVENUE	RCRA-CESQG	Higher	1481, 0.280, NE
L73		1420 25TH AVE	EDR US Hist Auto Stat	Higher	1481, 0.280, NE
M74		901 23RD AVENUE	ERNS	Lower	1486, 0.281, ESE
N75		3215 WEST BEACH BLVD	ERNS	Higher	1496, 0.283, WSW
N76		3215 WEST BEACH BLVD	ERNS	Higher	1496, 0.283, WSW
N77		3215 WEST BEACH BLVD	ERNS	Higher	1496, 0.283, WSW

MAPPED SITES SUMMARY

Target Property Address:  
 WEST BEACH BOULEVARD  
 GULFPORT, MS 39501

Click on Map ID to see full detail.

MAP ID	SITE NAME	ADDRESS	DATABASE ACRONYMS	RELATIVE ELEVATION	DIST (ft. & mi.) DIRECTION
<a href="#">N78</a>		3215 WEST BEACH BLVD	ERNS	Higher	1496, 0.283, WSW
<a href="#">N79</a>		3215 WEST BEACH BLVD	ERNS	Higher	1496, 0.283, WSW
<a href="#">N80</a>		3215 WEST BEACH BLVD	ERNS	Higher	1496, 0.283, WSW
<a href="#">81</a>	ARIZONA CHEMICAL		SHWS	Higher	1539, 0.291, NE
<a href="#">N82</a>		BEHIND THE GRAND CAS	ERNS	Higher	1546, 0.293, WSW
<a href="#">N83</a>		COMMERCIAL SHRIMP HA	ERNS	Higher	1546, 0.293, WSW
<a href="#">O84</a>	BAY ICE COMPANY, INC	1413 30TH AVENUE	ICIS, FINDS	Higher	1636, 0.310, NNW
<a href="#">L85</a>	HANCOCK BANK	2510 14TH STREET	ASBESTOS	Higher	1658, 0.314, NNE
<a href="#">L86</a>		2510 14TH ST	EDR US Hist Cleaners	Higher	1658, 0.314, NNE
<a href="#">L87</a>	HANCOCK BANK	2510 14TH STREET	UST	Higher	1658, 0.314, NNE
<a href="#">L88</a>	HANCOCK BANK	2510 14TH STREET	FINDS	Higher	1658, 0.314, NNE
<a href="#">L89</a>		2501 14TH ST	EDR US Hist Cleaners	Higher	1665, 0.315, NNE
<a href="#">L90</a>	2500 14TH STREET	2500 14TH STREET	FINDS	Higher	1673, 0.317, NNE
<a href="#">M91</a>		890 23RD AVE,JONES P	ERNS	Lower	1695, 0.321, ESE
<a href="#">M92</a>	MISCO MARINE-LADY LU		SHWS	Lower	1698, 0.322, ESE
<a href="#">P93</a>		991 23RD AVE	ERNS	Lower	1812, 0.343, East
<a href="#">P94</a>		991 23RD AVE.	ERNS	Lower	1812, 0.343, East
<a href="#">P95</a>		991 23RD AVE	ERNS	Lower	1812, 0.343, East
<a href="#">P96</a>		991 23RD AVE	ERNS	Lower	1812, 0.343, East
<a href="#">P97</a>	US COAST GUARD STATI	991 23RD AVENUE	RCRA-CESQG	Lower	1812, 0.343, East
<a href="#">P98</a>		991 23RD AVE	ERNS	Lower	1812, 0.343, East
<a href="#">P99</a>		991 23RD AVE	ERNS	Lower	1812, 0.343, East
<a href="#">P100</a>		991 23RD AVE	ERNS	Lower	1812, 0.343, East
<a href="#">P101</a>		991 23RD AVE.	ERNS	Lower	1812, 0.343, East
<a href="#">P102</a>		991 23RD AVE	ERNS	Lower	1812, 0.343, East
<a href="#">P103</a>		991 23RD AVE	ERNS	Lower	1812, 0.343, East
<a href="#">P104</a>		991 23RD AVE.	ERNS	Lower	1812, 0.343, East
<a href="#">P105</a>		991 23RD AVE	ERNS	Lower	1812, 0.343, East
<a href="#">P106</a>		991 23RD AVE	ERNS	Lower	1812, 0.343, East
<a href="#">Q107</a>		3315 WEST BEACH BLVD	ERNS	Higher	1815, 0.344, WSW
<a href="#">Q108</a>		3315 WEST BEACH BLVD	ERNS	Higher	1815, 0.344, WSW
<a href="#">Q109</a>		3315 WEST BEACH BLVD	ERNS	Higher	1815, 0.344, WSW
<a href="#">Q110</a>		3315 WEST BEACH BLVD	ERNS	Higher	1815, 0.344, WSW
<a href="#">Q111</a>		3315 WEST BEACH BLVD	ERNS	Higher	1853, 0.351, WSW
<a href="#">O112</a>	GULFPORT PAPER	3019 15TH STREET	FINDS	Higher	1930, 0.366, NNW
<a href="#">O113</a>	GULFPORT PAPER	3019 15TH STREET	UST	Higher	1930, 0.366, NNW
<a href="#">114</a>	FEB DISTRIBUTING COM	1520 29TH AVENUE	UST	Higher	1977, 0.374, North
<a href="#">R115</a>		1512 30TH AVE	EDR US Hist Cleaners	Higher	1989, 0.377, NNW
<a href="#">R116</a>		1518 30TH AVE	EDR US Hist Cleaners	Higher	2008, 0.380, NNW

MAPPED SITES SUMMARY

Target Property Address:  
WEST BEACH BOULEVARD  
GULFPORT, MS 39501

Click on Map ID to see full detail.

MAP ID	SITE NAME	ADDRESS	DATABASE ACRONYMS	RELATIVE ELEVATION	DIST (ft. & mi.) DIRECTION
<a href="#">S117</a>	MARKHAM HOTEL		SHWS	Higher	2023, 0.383, NE
<a href="#">118</a>		2510 16TH ST	EDR US Hist Auto Stat	Higher	2056, 0.389, NNE
<a href="#">P119</a>	JOSEPH T JONES HARBO	2265 JONES PARK DRIV	LUST, UST	Lower	2068, 0.392, East
<a href="#">S120</a>	SALVAGE NINE	2317 14TH STREET	FINDS	Higher	2206, 0.418, NE
<a href="#">121</a>	E-Z SERVE #4390	3416 WEST HIGHWAY 90	LUST, UST	Higher	2253, 0.427, WSW
<a href="#">T122</a>		1422 23RD AVE	ERNS	Higher	2373, 0.449, NE
<a href="#">T123</a>	JOSEPH T JONES BUILD	1422 23RD AVENUE	FINDS	Higher	2373, 0.449, NE
<a href="#">T124</a>	GULFPORT, MS, CITY O	2309 15TH STREET	ICIS, FINDS	Higher	2483, 0.470, NE
<a href="#">T125</a>	GULFPORT CENTRAL FIR	2309 15TH STREET	UST	Higher	2483, 0.470, NE
<a href="#">T126</a>	GULFPORT CENTRAL FIR	2309 15TH STREET	FINDS	Higher	2483, 0.470, NE
<a href="#">127</a>		2603 17TH ST	EDR US Hist Auto Stat	Higher	2603, 0.493, NNE
<a href="#">128</a>	GULFPORT YACHT CLUB		SHWS	Lower	2607, 0.494, SE
<a href="#">U129</a>	DOWNTOWN SERVICE STA	2201 14TH STREET	RGA LUST	Higher	2613, 0.495, ENE
<a href="#">U130</a>		2201 14TH ST	EDR US Hist Auto Stat	Higher	2613, 0.495, ENE
<a href="#">U131</a>	DOWNTOWN SERVICE STA	2201 14TH STREET	LUST, UST	Higher	2613, 0.495, ENE
<a href="#">V132</a>	GULFPORT POLICE OPER	1520 23RD AVENUE	UST	Higher	2620, 0.496, NE
<a href="#">V133</a>	GULFPORT POLICE OPER	1520 23RD AVENUE	FINDS	Higher	2620, 0.496, NE
<a href="#">134</a>		3317 15TH ST	EDR US Hist Auto Stat	Higher	2627, 0.498, NW
<a href="#">W135</a>	TURAN-FOLEY CADILLAC	1708 25TH AVENUE	LUST, UST	Higher	2746, 0.520, NNE
<a href="#">W136</a>	TURAN FOLEY OLDS - C	1708 25TH AVENUE	RCRA NonGen / NLR	Higher	2746, 0.520, NNE
<a href="#">X137</a>	GULF CITIES GAS CO	23RD AVE	EDR MGP	Higher	2761, 0.523, NE
<a href="#">138</a>	MCBC GULFPORT FAMILY	3502 EAST 8TH STREET	RCRA-CESQG	Higher	2819, 0.534, WSW
<a href="#">X139</a>	VERIZON BUSINESS INC	1608 23RD AVENUE	UST	Higher	2870, 0.544, NE
<a href="#">140</a>	HARRISON COUNTY - CU	COUNTY CURBSIDE PICK	SWRCY	Higher	2959, 0.560, NNE
<a href="#">Y141</a>	GOODYEAR AUTO SERVIC	1809 25TH AVENUE	RCRA-CESQG	Higher	3090, 0.585, NNE
<a href="#">Y142</a>	GOODYEAR ASC 2733	1809 25TH AVENUE	UST	Higher	3090, 0.585, NNE
<a href="#">Y143</a>		1809 25TH AVE	EDR US Hist Auto Stat	Higher	3090, 0.585, NNE
<a href="#">Z144</a>	TURAN LANE CHEVROLET	2120 15TH STREET	LUST, UST	Higher	3112, 0.589, NE
<a href="#">Z145</a>		2120 15TH ST	EDR US Hist Auto Stat	Higher	3112, 0.589, NE
<a href="#">Z146</a>	TURAN-LANE CHEVROLET	2120 15TH STREET	RCRA NonGen / NLR	Higher	3112, 0.589, NE
<a href="#">147</a>	HARDYS SHIP SERVICE	1600 22ND AVENUE	RCRA NonGen / NLR	Higher	3185, 0.603, NE
<a href="#">Z148</a>	TURAN FOLEY DEALERSH		SHWS	Higher	3279, 0.621, NE
<a href="#">AA149</a>	USPS-GULFPORT VMF	2801 19TH STREET	RCRA-CESQG	Higher	3342, 0.633, North
<a href="#">AA150</a>	GULFPORT VEHICLE MAI	2801 19TH STREET	LUST, UST	Higher	3342, 0.633, North
<a href="#">151</a>	BROADWATER SEA COUR	2000 EAST BEACH BOUL	UST	Higher	3355, 0.635, ENE
<a href="#">AA152</a>	19TH STREET FUEL & W	2880 19TH ST	AST	Higher	3357, 0.636, North
<a href="#">153</a>	HARRISON COUNTY CIVI	1801 23RD AVENUE	UST	Higher	3399, 0.644, NNE
<a href="#">154</a>	BST GULFPORT CO 7710	1723 22ND AVENUE	UST	Higher	3442, 0.652, NE
<a href="#">155</a>	MCMURTRY'S AUTO MACH	1908 25TH AVENUE	RCRA-CESQG	Higher	3488, 0.661, NNE

MAPPED SITES SUMMARY

Target Property Address:  
 WEST BEACH BOULEVARD  
 GULFPORT, MS 39501

Click on Map ID to see full detail.

MAP ID	SITE NAME	ADDRESS	DATABASE ACRONYMS	RELATIVE ELEVATION	DIST (ft. & mi.) DIRECTION
<a href="#">AB156</a>	WARFIELDS AUTO BODY	1814 33RD AVENUE	RCRA-CESQG	Higher	3515, 0.666, NNW
<a href="#">AB157</a>		1814 33RD AVE	EDR US Hist Auto Stat	Higher	3515, 0.666, NNW
<a href="#">AC158</a>	PETE'S ELECTRIC SERV	2420 19TH STREET	RCRA-CESQG	Higher	3550, 0.672, NNE
<a href="#">AC159</a>		2407 19TH ST	EDR US Hist Auto Stat	Higher	3560, 0.674, NNE
<a href="#">AC160</a>	KENNY YOUNG'S ENGINE	2407 19TH STREET	RCRA-CESQG	Higher	3560, 0.674, NNE
<a href="#">AA161</a>	MDOT - GULFPORT SERV		SHWS	Higher	3594, 0.681, North
<a href="#">AD162</a>		3820 W RAILROAD ST	EDR US Hist Auto Stat	Higher	3698, 0.700, West
<a href="#">AD163</a>	RONNY'S AUTOMOTIVE	3820 WEST RAILROAD S	UST	Higher	3698, 0.700, West
<a href="#">AD164</a>	RONNIES AUTOMOTIVE	3820 WEST RAILROAD	RCRA-CESQG	Higher	3698, 0.700, West
<a href="#">165</a>		2005 30TH AVE	EDR US Hist Cleaners	Higher	3822, 0.724, North
<a href="#">166</a>	THERMO-KING	2510 20TH ST	RCRA-CESQG	Higher	3824, 0.724, NNE
<a href="#">167</a>		3109 20TH ST	EDR US Hist Cleaners	Higher	3922, 0.743, NNW
<a href="#">168</a>		2415 20TH ST	EDR US Hist Cleaners	Higher	3931, 0.745, NNE
<a href="#">AE169</a>	2120 25TH AV	2120 25TH AV	US BROWNFIELDS	Higher	4287, 0.812, NNE
<a href="#">170</a>	MID SOUTH RR REFUELI		SHWS	Higher	4502, 0.853, North
<a href="#">AE171</a>	BROADNAX PROPERTY (P		SHWS	Higher	4519, 0.856, NNE
<a href="#">172</a>	MILLER PROPERTY - 21		SHWS	Higher	4618, 0.875, NNE
<a href="#">173</a>	MDOT - JOE SCHAPENS		SHWS	Higher	4704, 0.891, North
<a href="#">174</a>	DIXIE #10	4100 WEST BEACH STRE	LUST	Higher	4756, 0.901, WSW
<a href="#">175</a>	PARKSIDE EXXON	4220 WEST BEACH BOUL	LUST	Higher	5180, 0.981, WSW
<a href="#">176</a>	MDOT - GULFPORT 2513		SHWS	Higher	6074, 1.150, North
<a href="#">177</a>	HOLCOMB PAINT FACTOR		SHWS	Higher	6146, 1.164, NNW
<a href="#">178</a>	GULFPORT TIRE		SHWS	Higher	7568, 1.433, NE

# EXECUTIVE SUMMARY

## TARGET PROPERTY SEARCH RESULTS

The target property was not listed in any of the databases searched by EDR.

## DATABASES WITH NO MAPPED SITES

No mapped sites were found in EDR's search of available ("reasonably ascertainable ") government records either on the target property or within the search radius around the target property for the following databases:

## STANDARD ENVIRONMENTAL RECORDS

### ***Federal NPL site list***

NPL..... National Priority List  
Proposed NPL..... Proposed National Priority List Sites  
NPL LIENS..... Federal Superfund Liens

### ***Federal Delisted NPL site list***

Delisted NPL..... National Priority List Deletions

### ***Federal CERCLIS list***

FEDERAL FACILITY..... Federal Facility Site Information listing  
CERCLIS..... Comprehensive Environmental Response, Compensation, and Liability Information System

### ***Federal CERCLIS NFRAP site List***

CERC-NFRAP..... CERCLIS No Further Remedial Action Planned

### ***Federal RCRA CORRACTS facilities list***

CORRACTS..... Corrective Action Report

### ***Federal RCRA non-CORRACTS TSD facilities list***

RCRA-TSDF..... RCRA - Treatment, Storage and Disposal

### ***Federal RCRA generators list***

RCRA-LQG..... RCRA - Large Quantity Generators  
RCRA-SQG..... RCRA - Small Quantity Generators

### ***Federal institutional controls / engineering controls registries***

LUCIS..... Land Use Control Information System  
US ENG CONTROLS..... Engineering Controls Sites List  
US INST CONTROL..... Sites with Institutional Controls



## EXECUTIVE SUMMARY

### ***State and tribal landfill and/or solid waste disposal site lists***

SWF/LF..... Solid Waste Landfills  
DEBRIS..... Debris Site Locations Listing

### ***State and tribal leaking storage tank lists***

INDIAN LUST..... Leaking Underground Storage Tanks on Indian Land

### ***State and tribal registered storage tank lists***

FEMA UST..... Underground Storage Tank Listing  
INDIAN UST..... Underground Storage Tanks on Indian Land

### ***State and tribal institutional control / engineering control registries***

ENG CONTROLS..... Sites with Engineering Controls  
INST CONTROL..... Sites with Institutional Controls

### ***State and tribal voluntary cleanup sites***

INDIAN VCP..... Voluntary Cleanup Priority Listing

### ***State and tribal Brownfields sites***

BROWNFIELDS..... Uncontrolled Sites List

### **ADDITIONAL ENVIRONMENTAL RECORDS**

#### ***Local Lists of Landfill / Solid Waste Disposal Sites***

SWTIRE..... Commercial Waste Tire Haulers  
INDIAN ODI..... Report on the Status of Open Dumps on Indian Lands  
ODI..... Open Dump Inventory  
DEBRIS REGION 9..... Torres Martinez Reservation Illegal Dump Site Locations

#### ***Local Lists of Hazardous waste / Contaminated Sites***

US HIST CDL..... National Clandestine Laboratory Register  
US CDL..... Clandestine Drug Labs

#### ***Local Land Records***

LIENS 2..... CERCLA Lien Information

#### ***Records of Emergency Release Reports***

HMIRS..... Hazardous Materials Information Reporting System

#### ***Other Ascertainable Records***

FUDS..... Formerly Used Defense Sites  
SCRD DRYCLEANERS..... State Coalition for Remediation of Drycleaners Listing

## EXECUTIVE SUMMARY

US FIN ASSUR.....	Financial Assurance Information
EPA WATCH LIST.....	EPA WATCH LIST
2020 COR ACTION.....	2020 Corrective Action Program List
TSCA.....	Toxic Substances Control Act
TRIS.....	Toxic Chemical Release Inventory System
SSTS.....	Section 7 Tracking Systems
ROD.....	Records Of Decision
RMP.....	Risk Management Plans
RAATS.....	RCRA Administrative Action Tracking System
PRP.....	Potentially Responsible Parties
PADS.....	PCB Activity Database System
FTTS.....	FIFRA/ TSCA Tracking System - FIFRA (Federal Insecticide, Fungicide, & Rodenticide Act)/TSCA (Toxic Substances Control Act)
MLTS.....	Material Licensing Tracking System
COAL ASH DOE.....	Steam-Electric Plant Operation Data
COAL ASH EPA.....	Coal Combustion Residues Surface Impoundments List
PCB TRANSFORMER.....	PCB Transformer Registration Database
RADINFO.....	Radiation Information Database
HIST FTTS.....	FIFRA/TSCA Tracking System Administrative Case Listing
DOT OPS.....	Incident and Accident Data
CONSENT.....	Superfund (CERCLA) Consent Decrees
INDIAN RESERV.....	Indian Reservations
UMTRA.....	Uranium Mill Tailings Sites
LEAD SMELTERS.....	Lead Smelter Sites
US AIRS.....	Aerometric Information Retrieval System Facility Subsystem
US MINES.....	Mines Master Index File
AIRS.....	Air Quality Information Listing
DRYCLEANERS.....	Drycleaner Facilities Listing
NPDES.....	Industrial & Municipal NPDES Facilities
PERMITS.....	Environmental Site Information System Listing
UIC.....	UIC Information

### EDR RECOVERED GOVERNMENT ARCHIVES

#### *Exclusive Recovered Govt. Archives*

RGA HWS.....	Recovered Government Archive State Hazardous Waste Facilities List
RGA LF.....	Recovered Government Archive Solid Waste Facilities List

### SURROUNDING SITES: SEARCH RESULTS

Surrounding sites were identified in the following databases.

Elevations have been determined from the USGS Digital Elevation Model and should be evaluated on a relative (not an absolute) basis. Relative elevation information between sites of close proximity should be field verified. Sites with an elevation equal to or higher than the target property have been differentiated below from sites with an elevation lower than the target property.

Page numbers and map identification numbers refer to the EDR Radius Map report where detailed data on individual sites can be reviewed.

Sites listed in ***bold italics*** are in multiple databases.

Unmappable (orphan) sites are not considered in the foregoing analysis.

## EXECUTIVE SUMMARY

### STANDARD ENVIRONMENTAL RECORDS

#### ***Federal RCRA generators list***

RCRA-CESQG: RCRAInfo is EPA's comprehensive information system, providing access to data supporting the Resource Conservation and Recovery Act (RCRA) of 1976 and the Hazardous and Solid Waste Amendments (HSWA) of 1984. The database includes selective information on sites which generate, transport, store, treat and/or dispose of hazardous waste as defined by the Resource Conservation and Recovery Act (RCRA). Conditionally exempt small quantity generators (CESQGs) generate less than 100 kg of hazardous waste, or less than 1 kg of acutely hazardous waste per month.

A review of the RCRA-CESQG list, as provided by EDR, and dated 03/10/2015 has revealed that there are 16 RCRA-CESQG sites within approximately 0.75 miles of the target property.

<u>Equal/Higher Elevation</u>	<u>Address</u>	<u>Direction / Distance</u>	<u>Map ID</u>	<u>Page</u>
<b>CHIQUITA BRANDS INC</b>	<b>HIGHWAY 90 &amp; 30TH AV</b>	<b>WNW 0 - 1/8 (0.122 mi.)</b>	<b>B14</b>	<b>21</b>
MOSERS AUTO SERVICE	2800 13TH STREET	N 1/8 - 1/4 (0.201 mi.)	E38	47
K & K PERFORMANCE SH	2800 13TH ST	N 1/8 - 1/4 (0.201 mi.)	E40	49
ASTRO LINCOLN-MERCUR	2617 13TH STREET	NNE 1/8 - 1/4 (0.219 mi.)	F43	51
AMERICAN LINEN	1316 30TH AVENUE	NNW 1/8 - 1/4 (0.239 mi.)	I56	61
FIRESTONE STORES	1420 25TH AVENUE	NE 1/4 - 1/2 (0.280 mi.)	L72	76
MCBC GULFPORT FAMILY	3502 EAST 8TH STREET	WSW 1/2 - 1 (0.534 mi.)	138	114
GOODYEAR AUTO SERVIC	1809 25TH AVENUE	NNE 1/2 - 1 (0.585 mi.)	Y141	117
USPS-GULFPORT VMF	2801 19TH STREET	N 1/2 - 1 (0.633 mi.)	AA149	125
MCMURTRY'S AUTO MACH	1908 25TH AVENUE	NNE 1/2 - 1 (0.661 mi.)	155	133
WARFIELDS AUTO BODY	1814 33RD AVENUE	NNW 1/2 - 1 (0.666 mi.)	AB156	135
PETE'S ELECTRIC SERV	2420 19TH STREET	NNE 1/2 - 1 (0.672 mi.)	AC158	138
KENNY YOUNG'S ENGINE	2407 19TH STREET	NNE 1/2 - 1 (0.674 mi.)	AC160	139
RONNIES AUTOMOTIVE	3820 WEST RAILROAD	W 1/2 - 1 (0.700 mi.)	AD164	143
THERMO-KING	2510 20TH ST	NNE 1/2 - 1 (0.724 mi.)	166	145
<u>Lower Elevation</u>	<u>Address</u>	<u>Direction / Distance</u>	<u>Map ID</u>	<u>Page</u>
US COAST GUARD STATI	991 23RD AVENUE	E 1/4 - 1/2 (0.343 mi.)	P97	85

#### ***Federal ERNS list***

ERNS: The Emergency Response Notification System records and stores information on reported releases of oil and hazardous substances. The source of this database is the U.S. EPA.

A review of the ERNS list, as provided by EDR, and dated 03/30/2015 has revealed that there are 33 ERNS sites within approximately 0.5 miles of the target property.

<u>Equal/Higher Elevation</u>	<u>Address</u>	<u>Direction / Distance</u>	<u>Map ID</u>	<u>Page</u>
Not reported	877 COPA BLVD	ENE 0 - 1/8 (0.066 mi.)	A4	12
Not reported	1000 30TH AVE	W 0 - 1/8 (0.101 mi.)	B5	12
Not reported	PO BOX 1689 ON EAST	NE 1/8 - 1/4 (0.229 mi.)	G46	54
Not reported	POB 40	NE 1/4 - 1/2 (0.251 mi.)	F61	66
Not reported	3215 WEST BEACH BLVD	WSW 1/4 - 1/2 (0.283 mi.)	N75	78
Not reported	3215 WEST BEACH BLVD	WSW 1/4 - 1/2 (0.283 mi.)	N76	78
Not reported	3215 WEST BEACH BLVD	WSW 1/4 - 1/2 (0.283 mi.)	N77	78
Not reported	3215 WEST BEACH BLVD	WSW 1/4 - 1/2 (0.283 mi.)	N78	78
Not reported	3215 WEST BEACH BLVD	WSW 1/4 - 1/2 (0.283 mi.)	N79	78

## EXECUTIVE SUMMARY

<u>Equal/Higher Elevation</u>	<u>Address</u>	<u>Direction / Distance</u>	<u>Map ID</u>	<u>Page</u>
Not reported	3215 WEST BEACH BLVD	WSW 1/4 - 1/2 (0.283 mi.)	N80	79
Not reported	BEHIND THE GRAND CAS	WSW 1/4 - 1/2 (0.293 mi.)	N82	79
Not reported	COMMERCIAL SHRIMP HA	WSW 1/4 - 1/2 (0.293 mi.)	N83	79
Not reported	3315 WEST BEACH BLVD	WSW 1/4 - 1/2 (0.344 mi.)	Q107	88
Not reported	3315 WEST BEACH BLVD	WSW 1/4 - 1/2 (0.344 mi.)	Q108	89
Not reported	3315 WEST BEACH BLVD	WSW 1/4 - 1/2 (0.344 mi.)	Q109	89
Not reported	3315 WEST BEACH BLVD	WSW 1/4 - 1/2 (0.344 mi.)	Q110	89
Not reported	3315 WEST BEACH BLVD	WSW 1/4 - 1/2 (0.351 mi.)	Q111	89
Not reported	1422 23RD AVE	NE 1/4 - 1/2 (0.449 mi.)	T122	102

<u>Lower Elevation</u>	<u>Address</u>	<u>Direction / Distance</u>	<u>Map ID</u>	<u>Page</u>
Not reported	901 23RD AVENUE	ESE 1/4 - 1/2 (0.281 mi.)	M74	78
Not reported	890 23RD AVE, JONES P	ESE 1/4 - 1/2 (0.321 mi.)	M91	84
Not reported	991 23RD AVE	E 1/4 - 1/2 (0.343 mi.)	P93	85
Not reported	991 23RD AVE.	E 1/4 - 1/2 (0.343 mi.)	P94	85
Not reported	991 23RD AVE	E 1/4 - 1/2 (0.343 mi.)	P95	85
Not reported	991 23RD AVE	E 1/4 - 1/2 (0.343 mi.)	P96	85
Not reported	991 23RD AVE	E 1/4 - 1/2 (0.343 mi.)	P98	87
Not reported	991 23RD AVE	E 1/4 - 1/2 (0.343 mi.)	P99	87
Not reported	991 23RD AVE	E 1/4 - 1/2 (0.343 mi.)	P100	87
Not reported	991 23RD AVE.	E 1/4 - 1/2 (0.343 mi.)	P101	87
Not reported	991 23RD AVE	E 1/4 - 1/2 (0.343 mi.)	P102	88
Not reported	991 23RD AVE	E 1/4 - 1/2 (0.343 mi.)	P103	88
Not reported	991 23RD AVE.	E 1/4 - 1/2 (0.343 mi.)	P104	88
Not reported	991 23RD AVE	E 1/4 - 1/2 (0.343 mi.)	P105	88
Not reported	991 23RD AVE	E 1/4 - 1/2 (0.343 mi.)	P106	88

### ***State- and tribal - equivalent CERCLIS***

SHWS: The State Hazardous Waste Sites records are the states' equivalent to CERCLIS. These sites may or may not already be listed on the federal CERCLIS list. Priority sites planned for cleanup using state funds (state equivalent of Superfund) are identified along with sites where cleanup will be paid for by potentially responsible parties. The data come from the Department of Environmental Quality's Uncontrolled Site Project Tracking System.

A review of the SHWS list, as provided by EDR, and dated 06/15/2015 has revealed that there are 19 SHWS sites within approximately 1.5 miles of the target property.

<u>Equal/Higher Elevation</u>	<u>Address</u>	<u>Direction / Distance</u>	<u>Map ID</u>	<u>Page</u>
SEARS FACILITY #7456 Status: Inactive EPA ID: MSR000000950		ENE 0 - 1/8 (0.033 mi.)	A1	7
<b>AMERIPRIDE LINEN &amp; A</b> Status: SNFA		<b>NNW 1/8 - 1/4 (0.238 mi.)</b>	<b>I54</b>	<b>60</b>
HIGH TECH SERVICES		NNW 1/8 - 1/4 (0.243 mi.)	H58	65
BARRETT'S CLEANERS Status: SNFA		NNE 1/8 - 1/4 (0.248 mi.)	J59	65
MDOT - AMERIPRIDE LI Status: SNFA/Reopened		NNE 1/8 - 1/4 (0.248 mi.)	F60	66
MDOT - LAZANA PROPER		N 1/4 - 1/2 (0.278 mi.)	K67	73

## EXECUTIVE SUMMARY

Status: SNFA				
ARIZONA CHEMICAL EPA ID: MSD001661719	NE 1/4 - 1/2 (0.291 mi.)	81	79	
MARKHAM HOTEL TURAN FOLEY DEALERSH Status: SNFA	NE 1/4 - 1/2 (0.383 mi.) NE 1/2 - 1 (0.621 mi.)	S117 Z148	92 124	
MDOT - GULFPORT SERV Status: SNFA	N 1/2 - 1 (0.681 mi.)	AA161	140	
MID SOUTH RR REFUELI Status: RUAO	N 1/2 - 1 (0.853 mi.)	170	158	
BROADNAX PROPERTY (P) Status: SNFA	NNE 1/2 - 1 (0.856 mi.)	AE171	158	
MILLER PROPERTY - 21 MDOT - JOE SCHAPENS Status: SNFA	NNE 1/2 - 1 (0.875 mi.) N 1/2 - 1 (0.891 mi.)	172 173	159 159	
MDOT - GULFPORT 2513 HOLCOMB PAINT FACTOR Status: Inactive	N 1 - 2 (1.150 mi.) NNW 1 - 2 (1.164 mi.)	176 177	161 162	
<b>GULFPORT TIRE</b> Status: BFA	<b>NE 1 - 2 (1.433 mi.)</b>	<b>178</b>	<b>162</b>	
<b>Lower Elevation</b>	<b>Address</b>	<b>Direction / Distance</b>	<b>Map ID</b>	<b>Page</b>
MISCO MARINE-LADY LU Status: SNFA		ESE 1/4 - 1/2 (0.322 mi.)	M92	84
GULFPORT YACHT CLUB Status: Inactive		SE 1/4 - 1/2 (0.494 mi.)	128	106

### **State and tribal leaking storage tank lists**

LUST: The Leaking Underground Storage Tank Incident Reports contain an inventory of reported leaking underground storage tank incidents. The data come from the Department of Environmental Quality's LUST Status Report.

A review of the LUST list, as provided by EDR, and dated 06/24/2015 has revealed that there are 16 LUST sites within approximately 1 mile of the target property.

<u>Equal/Higher Elevation</u>	<u>Address</u>	<u>Direction / Distance</u>	<u>Map ID</u>	<u>Page</u>
<b>JR FOOD MART #39</b> Status Code: Closed Status Code: Open Facility Status: Inactive Facility Id: 5396	<b>2605 WEST BEACH BOUL</b>	<b>ENE 0 - 1/8 (0.120 mi.)</b>	<b>C11</b>	<b>14</b>
<b>MS STATE PORT AUTHORITY</b> Status Code: Closed Facility Status: Inactive Facility Id: 748	<b>30TH AVE SOUTH OF HI</b>	<b>WNW 0 - 1/8 (0.122 mi.)</b>	<b>B13</b>	<b>17</b>
<b>FORMER BARON #75</b>	<b>2501 WEST BEACH BOUL</b>	<b>ENE 1/8 - 1/4 (0.134 mi.)</b>	<b>C15</b>	<b>26</b>

## EXECUTIVE SUMMARY

Status Code: Closed Facility Status: Inactive Facility Id: 752				
<b>FAST MART #23</b>	<b>1119 30TH AVENUE</b>	<b>NW 1/8 - 1/4 (0.145 mi.)</b>	<b>D26</b>	<b>34</b>
Status Code: Closed Facility Status: Active Facility Id: 4251				
<b>P T DELI #1</b>	<b>3000 12TH STREET</b>	<b>NW 1/8 - 1/4 (0.169 mi.)</b>	<b>D30</b>	<b>39</b>
Status Code: Closed Status Code: Open Facility Status: Inactive Facility Id: 168				
<b>COLONIAL TRAILWAYS B</b>	<b>2805 13TH STREET</b>	<b>N 1/8 - 1/4 (0.188 mi.)</b>	<b>E35</b>	<b>44</b>
Status Code: Closed Facility Status: Inactive Facility Id: 1684				
<b>MAC'S QUICK STOP</b>	<b>1301 30TH AVENUE</b>	<b>NNW 1/8 - 1/4 (0.234 mi.)</b>	<b>I52</b>	<b>58</b>
Status Code: Closed Facility Status: Inactive Facility Id: 4478				
<b>FIRESTONE STORE #050</b>	<b>1420 25TH AVENUE</b>	<b>NE 1/4 - 1/2 (0.280 mi.)</b>	<b>L71</b>	<b>75</b>
Status Code: Closed Facility Status: Inactive Facility Id: 2008				
<b>E-Z SERVE #4390</b>	<b>3416 WEST HIGHWAY 90</b>	<b>WSW 1/4 - 1/2 (0.427 mi.)</b>	<b>121</b>	<b>96</b>
Status Code: Closed Facility Status: Inactive Facility Id: 3057				
<b>DOWNTOWN SERVICE STA</b>	<b>2201 14TH STREET</b>	<b>ENE 1/4 - 1/2 (0.495 mi.)</b>	<b>U131</b>	<b>107</b>
Status Code: Open Facility Status: Inactive Facility Id: 10749				
<b>TURAN-FOLEY CADILLAC</b>	<b>1708 25TH AVENUE</b>	<b>NNE 1/2 - 1 (0.520 mi.)</b>	<b>W135</b>	<b>111</b>
Status Code: Closed Facility Status: Inactive Facility Id: 2983				
<b>TURAN LANE CHEVROLET</b>	<b>2120 15TH STREET</b>	<b>NE 1/2 - 1 (0.589 mi.)</b>	<b>Z144</b>	<b>120</b>
Status Code: Closed Facility Status: Inactive Facility Id: 10741				
<b>GULFPORT VEHICLE MAI</b>	<b>2801 19TH STREET</b>	<b>N 1/2 - 1 (0.633 mi.)</b>	<b>AA150</b>	<b>127</b>
Status Code: Closed Facility Status: Inactive Facility Id: 6583				
<b>DIXIE #10</b>	<b>4100 WEST BEACH STRE</b>	<b>WSW 1/2 - 1 (0.901 mi.)</b>	<b>174</b>	<b>160</b>
Status Code: Closed Facility Status: Inactive Facility Id: 9745				
<b>PARKSIDE EXXON</b>	<b>4220 WEST BEACH BOUL</b>	<b>WSW 1/2 - 1 (0.981 mi.)</b>	<b>175</b>	<b>160</b>
Status Code: Closed Facility Status: Inactive				

## EXECUTIVE SUMMARY

Facility Id: 3634

<u>Lower Elevation</u>	<u>Address</u>	<u>Direction / Distance</u>	<u>Map ID</u>	<u>Page</u>
<b>JOSEPH T JONES HARBO</b> Status Code: Closed Facility Status: Inactive Facility Id: 12311	<b>2265 JONES PARK DRIV</b>	<b>E 1/4 - 1/2 (0.392 mi.)</b>	<b>P119</b>	<b>93</b>

### **State and tribal registered storage tank lists**

UST: The Underground Storage Tank database contains registered USTs. USTs are regulated under Subtitle I of the Resource Conservation and Recovery Act (RCRA). The data come from the Department of Environmental Quality's Underground Storage Tanks list.

A review of the UST list, as provided by EDR, and dated 06/24/2015 has revealed that there are 31 UST sites within approximately 0.75 miles of the target property.

<u>Equal/Higher Elevation</u>	<u>Address</u>	<u>Direction / Distance</u>	<u>Map ID</u>	<u>Page</u>
<b>SEARS #7456</b> Tank Status: Permanently Out of Use Facility Status: Inactive Facility Id: 11775	<b>2818 WEST BEACH BOUL</b>	<b>NNW 0 - 1/8 (0.034 mi.)</b>	<b>A2</b>	<b>7</b>
<b>JR FOOD MART #39</b> Tank Status: Permanently Out of Use Facility Status: Inactive Facility Id: 5396	<b>2605 WEST BEACH BOUL</b>	<b>ENE 0 - 1/8 (0.120 mi.)</b>	<b>C11</b>	<b>14</b>
<b>MS STATE PORT AUTHOUR</b> Tank Status: Permanently Out of Use Facility Status: Inactive Facility Id: 748	<b>30TH AVE SOUTH OF HI</b>	<b>WNW 0 - 1/8 (0.122 mi.)</b>	<b>B13</b>	<b>17</b>
<b>CHIQUITA BRANDS INC</b> Tank Status: Permanently Out of Use Facility Status: Inactive Facility Id: 517	<b>HIGHWAY 90 &amp; 30TH AV</b>	<b>WNW 0 - 1/8 (0.122 mi.)</b>	<b>B14</b>	<b>21</b>
<b>FORMER BARON #75</b> Tank Status: Permanently Out of Use Facility Status: Inactive Facility Id: 752	<b>2501 WEST BEACH BOUL</b>	<b>ENE 1/8 - 1/4 (0.134 mi.)</b>	<b>C15</b>	<b>26</b>
<b>MS POWER COMPANY GEN</b> Tank Status: Permanently Out of Use Facility Status: Inactive Facility Id: 10580	<b>2992 WEST BEACH BOUL</b>	<b>W 1/8 - 1/4 (0.136 mi.)</b>	<b>B18</b>	<b>29</b>
<b>FAST MART #23</b> Tank Status: Permanently Out of Use Tank Status: Currently In Use Facility Status: Active Facility Id: 4251	<b>1119 30TH AVENUE</b>	<b>NW 1/8 - 1/4 (0.145 mi.)</b>	<b>D26</b>	<b>34</b>
<b>P T DELI #1</b>	<b>3000 12TH STREET</b>	<b>NW 1/8 - 1/4 (0.169 mi.)</b>	<b>D30</b>	<b>39</b>



## EXECUTIVE SUMMARY

Tank Status: Permanently Out of Use Facility Status: Inactive Facility Id: 168				
<b>COLONIAL TRAILWAYS B</b>	<b>2805 13TH STREET</b>	<b>N 1/8 - 1/4 (0.188 mi.)</b>	<b>E35</b>	<b>44</b>
Tank Status: Permanently Out of Use Facility Status: Inactive Facility Id: 1684				
FORD DEALERSHIP	2617 13TH STREET	NNE 1/8 - 1/4 (0.219 mi.)	F44	53
Tank Status: Permanently Out of Use Facility Status: Inactive Facility Id: 1425				
<b>MAC'S QUICK STOP</b>	<b>1301 30TH AVENUE</b>	<b>NNW 1/8 - 1/4 (0.234 mi.)</b>	<b>I52</b>	<b>58</b>
Tank Status: Permanently Out of Use Facility Status: Inactive Facility Id: 4478				
AMERICAN LINEN SUPPL	1316 30TH AVENUE	NNW 1/8 - 1/4 (0.239 mi.)	I57	63
Tank Status: Permanently Out of Use Facility Status: Inactive Facility Id: 1666				
WHITNEY NATIONAL BAN	1300 25TH AVENUE	NE 1/4 - 1/2 (0.279 mi.)	L68	73
Tank Status: Permanently Out of Use Facility Status: Inactive Facility Id: 12714				
<b>FIRESTONE STORE #050</b>	<b>1420 25TH AVENUE</b>	<b>NE 1/4 - 1/2 (0.280 mi.)</b>	<b>L71</b>	<b>75</b>
Tank Status: Permanently Out of Use Facility Status: Inactive Facility Id: 2008				
HANCOCK BANK	2510 14TH STREET	NNE 1/4 - 1/2 (0.314 mi.)	L87	82
Tank Status: Permanently Out of Use Tank Status: Currently In Use Facility Status: Active Facility Id: 12057				
GULFPORT PAPER	3019 15TH STREET	NNW 1/4 - 1/2 (0.366 mi.)	O113	90
Tank Status: Permanently Out of Use Facility Status: Inactive Facility Id: 733				
FEB DISTRIBUTING COM	1520 29TH AVENUE	N 1/4 - 1/2 (0.374 mi.)	114	91
Tank Status: Permanently Out of Use Facility Status: Inactive Facility Id: 2160				
<b>E-Z SERVE #4390</b>	<b>3416 WEST HIGHWAY 90</b>	<b>WSW 1/4 - 1/2 (0.427 mi.)</b>	<b>121</b>	<b>96</b>
Tank Status: Permanently Out of Use Facility Status: Inactive Facility Id: 3057				
GULFPORT CENTRAL FIR	2309 15TH STREET	NE 1/4 - 1/2 (0.470 mi.)	T125	104
Tank Status: Permanently Out of Use Facility Status: Inactive Facility Id: 11645				
<b>DOWNTOWN SERVICE STA</b>	<b>2201 14TH STREET</b>	<b>ENE 1/4 - 1/2 (0.495 mi.)</b>	<b>U131</b>	<b>107</b>
Tank Status: Permanently Out of Use Facility Status: Inactive				

## EXECUTIVE SUMMARY

Facility Id: 10749					
GULFPORT POLICE OPER	1520 23RD AVENUE	NE 1/4 - 1/2 (0.496 mi.)	V132	110	
Tank Status: Permanently Out of Use					
Facility Status: Inactive					
Facility Id: 12194					
<b>TURAN-FOLEY CADILLAC</b>	<b>1708 25TH AVENUE</b>	<b>NNE 1/2 - 1 (0.520 mi.)</b>	<b>W135</b>	<b>111</b>	
Tank Status: Permanently Out of Use					
Facility Status: Inactive					
Facility Id: 2983					
VERIZON BUSINESS INC	1608 23RD AVENUE	NE 1/2 - 1 (0.544 mi.)	X139	116	
Tank Status: Permanently Out of Use					
Tank Status: Currently In Use					
Facility Status: Active					
Facility Id: 6715					
GOODYEAR ASC 2733	1809 25TH AVENUE	NNE 1/2 - 1 (0.585 mi.)	Y142	119	
Tank Status: Permanently Out of Use					
Facility Status: Inactive					
Facility Id: 7930					
<b>TURAN LANE CHEVROLET</b>	<b>2120 15TH STREET</b>	<b>NE 1/2 - 1 (0.589 mi.)</b>	<b>Z144</b>	<b>120</b>	
Tank Status: Permanently Out of Use					
Facility Status: Inactive					
Facility Id: 10741					
<b>GULFPORT VEHICLE MAI</b>	<b>2801 19TH STREET</b>	<b>N 1/2 - 1 (0.633 mi.)</b>	<b>AA150</b>	<b>127</b>	
Tank Status: Permanently Out of Use					
Facility Status: Inactive					
Facility Id: 6583					
BROADWATER SEA COURS	2000 EAST BEACH BOUL	ENE 1/2 - 1 (0.635 mi.)	151	130	
Tank Status: Permanently Out of Use					
Facility Status: Inactive					
Facility Id: 738					
HARRISON COUNTY CIVI	1801 23RD AVENUE	NNE 1/2 - 1 (0.644 mi.)	153	131	
Tank Status: Currently In Use					
Facility Status: Active					
Facility Id: 11222					
BST GULFPORT CO 7710	1723 22ND AVENUE	NE 1/2 - 1 (0.652 mi.)	154	132	
Tank Status: Permanently Out of Use					
Tank Status: Currently In Use					
Facility Status: Active					
Facility Id: 9237					
RONNY'S AUTOMOTIVE	3820 WEST RAILROAD S	W 1/2 - 1 (0.700 mi.)	AD163	142	
Tank Status: Permanently Out of Use					
Facility Status: Inactive					
Facility Id: 9622					
<b>Lower Elevation</b>	<b>Address</b>	<b>Direction / Distance</b>	<b>Map ID</b>	<b>Page</b>	
<b>JOSEPH T JONES HARBO</b>	<b>2265 JONES PARK DRIV</b>	<b>E 1/4 - 1/2 (0.392 mi.)</b>	<b>P119</b>	<b>93</b>	
Tank Status: Permanently Out of Use					
Facility Status: Inactive					
Facility Id: 12311					

## EXECUTIVE SUMMARY

AST: The Aboveground Storage Tank database contains registered ASTs. The data come from the Department of Environmental Quality's Aboveground Storage Tanks list.

A review of the AST list, as provided by EDR, and dated 06/09/2015 has revealed that there is 1 AST site within approximately 0.75 miles of the target property.

<u>Equal/Higher Elevation</u>	<u>Address</u>	<u>Direction / Distance</u>	<u>Map ID</u>	<u>Page</u>
19TH STREET FUEL & W	2880 19TH ST	N 1/2 - 1 (0.636 mi.)	AA152	131

### ***State and tribal voluntary cleanup sites***

VCP: Voluntary Evaluation Program Sites.

A review of the VCP list, as provided by EDR, and dated 06/15/2015 has revealed that there is 1 VCP site within approximately 1 mile of the target property.

<u>Equal/Higher Elevation</u>	<u>Address</u>	<u>Direction / Distance</u>	<u>Map ID</u>	<u>Page</u>
<b>AMERIPRIDE LINEN &amp; A</b>		<b>NNW 1/8 - 1/4 (0.238 mi.)</b>	<b>I54</b>	<b>60</b>

### **ADDITIONAL ENVIRONMENTAL RECORDS**

#### ***Local Brownfield lists***

US BROWNFIELDS: The EPA's listing of Brownfields properties from the Cleanups in My Community program, which provides information on Brownfields properties for which information is reported back to EPA, as well as areas served by Brownfields grant programs.

A review of the US BROWNFIELDS list, as provided by EDR, and dated 06/22/2015 has revealed that there are 3 US BROWNFIELDS sites within approximately 1 mile of the target property.

<u>Equal/Higher Elevation</u>	<u>Address</u>	<u>Direction / Distance</u>	<u>Map ID</u>	<u>Page</u>
AMERIPRIDE SERVICES	1329 29TH AVENUE	NNW 1/8 - 1/4 (0.233 mi.)	H49	55
FORMER BARRETT CLEAN	2711 14TH STREET	N 1/4 - 1/2 (0.270 mi.)	J62	67
2120 25TH AV	2120 25TH AV	NNE 1/2 - 1 (0.812 mi.)	AE169	147

#### ***Local Lists of Landfill / Solid Waste Disposal Sites***

SWRCY: A listing of recycling facilities.

A review of the SWRCY list, as provided by EDR, and dated 12/31/2013 has revealed that there is 1 SWRCY site within approximately 1 mile of the target property.

<u>Equal/Higher Elevation</u>	<u>Address</u>	<u>Direction / Distance</u>	<u>Map ID</u>	<u>Page</u>
HARRISON COUNTY - CU	COUNTY CURBSIDE PICK	NNE 1/2 - 1 (0.560 mi.)	140	117

## EXECUTIVE SUMMARY

### ***Other Ascertainable Records***

RCRA NonGen / NLR: RCRAInfo is EPA's comprehensive information system, providing access to data supporting the Resource Conservation and Recovery Act (RCRA) of 1976 and the Hazardous and Solid Waste Amendments (HSWA) of 1984. The database includes selective information on sites which generate, transport, store, treat and/or dispose of hazardous waste as defined by the Resource Conservation and Recovery Act (RCRA). Non-Generators do not presently generate hazardous waste.

A review of the RCRA NonGen / NLR list, as provided by EDR, and dated 03/10/2015 has revealed that there are 4 RCRA NonGen / NLR sites within approximately 0.75 miles of the target property.

<u>Equal/Higher Elevation</u>	<u>Address</u>	<u>Direction / Distance</u>	<u>Map ID</u>	<u>Page</u>
SUPERIOR CHRYSLER-PL	3002 WEST BEACH BOUL	W 1/8 - 1/4 (0.142 mi.)	B20	31
TURAN FOLEY OLDS - C	1708 25TH AVENUE	NNE 1/2 - 1 (0.520 mi.)	W136	112
TURAN-LANE CHEVROLET	2120 15TH STREET	NE 1/2 - 1 (0.589 mi.)	Z146	122
HARDYS SHIP SERVICE	1600 22ND AVENUE	NE 1/2 - 1 (0.603 mi.)	147	123

DOD: Consists of federally owned or administered lands, administered by the Department of Defense, that have any area equal to or greater than 640 acres of the United States, Puerto Rico, and the U.S. Virgin Islands.

A review of the DOD list, as provided by EDR, and dated 12/31/2005 has revealed that there is 1 DOD site within approximately 1.5 miles of the target property.

<u>Equal/Higher Elevation</u>	<u>Address</u>	<u>Direction / Distance</u>	<u>Map ID</u>	<u>Page</u>
NAVAL CONSTRUCTION B		NNW 1/2 - 1 (0.993 mi.)	0	7

ICIS: The Integrated Compliance Information System (ICIS) supports the information needs of the national enforcement and compliance program as well as the unique needs of the National Pollutant Discharge Elimination System (NPDES) program.

A review of the ICIS list, as provided by EDR, and dated 01/23/2015 has revealed that there are 3 ICIS sites within approximately 0.5 miles of the target property.

<u>Equal/Higher Elevation</u>	<u>Address</u>	<u>Direction / Distance</u>	<u>Map ID</u>	<u>Page</u>
<b>CHIQUITA BRANDS INC</b>	<b>HIGHWAY 90 &amp; 30TH AV</b>	<b>WNW 0 - 1/8 (0.122 mi.)</b>	<b>B14</b>	<b>21</b>
<b>BAY ICE COMPANY, INC</b>	<b>1413 30TH AVENUE</b>	<b>NNW 1/4 - 1/2 (0.310 mi.)</b>	<b>O84</b>	<b>80</b>
<b>GULFPORT, MS, CITY O</b>	<b>2309 15TH STREET</b>	<b>NE 1/4 - 1/2 (0.470 mi.)</b>	<b>T124</b>	<b>103</b>

FINDS: The Facility Index System contains both facility information and "pointers" to other sources of information that contain more detail. These include: RCRIS; Permit Compliance System (PCS); Aerometric Information Retrieval System (AIRS); FATES (FIFRA [Federal Insecticide Fungicide Rodenticide Act] and TSCA Enforcement System, FTTS [FIFRA/TSCA Tracking System]; CERCLIS; DOCKET (Enforcement Docket used to manage and track information on civil judicial enforcement cases for all environmental statutes); Federal Underground Injection Control (FURS); Federal Reporting Data System (FRDS); Surface Impoundments (SIA); TSCA Chemicals in Commerce Information System (CICS); PADS; RCRA-J (medical waste transporters/disposers); TRIS; and TSCA. The source of this database is the U.S. EPA/NTIS.

A review of the FINDS list, as provided by EDR, and dated 01/18/2015 has revealed that there are 29

## EXECUTIVE SUMMARY

FINDS sites within approximately 0.5 miles of the target property.

<u>Equal/Higher Elevation</u>	<u>Address</u>	<u>Direction / Distance</u>	<u>Map ID</u>	<u>Page</u>
SEARS NUMBER 7456	2818 WEST BEACH BOUL	NNW 0 - 1/8 (0.034 mi.)	A3	11
JR FOOD MART NUMBER	2605 WEST BEACH BOUL	ENE 0 - 1/8 (0.120 mi.)	C12	17
<b>CHIQUITA BRANDS INC</b>	<b>HIGHWAY 90 &amp; 30TH AV</b>	<b>WNW 0 - 1/8 (0.122 mi.)</b>	<b>B14</b>	<b>21</b>
MS POWER COMPANY GEN	2992 WEST BEACH BOUL	W 1/8 - 1/4 (0.136 mi.)	B19	30
SUPERIOR CHRYSLER PL	3002 WEST BEACH BOUL	W 1/8 - 1/4 (0.142 mi.)	B21	32
FAST TRAC NUMBER 23	1119 30TH AVENUE	NW 1/8 - 1/4 (0.145 mi.)	D28	39
EARTH CONSULTING GRO	3000 12TH STREET	NW 1/8 - 1/4 (0.169 mi.)	D31	43
COLONIAL TRAILWAYS B	2805 13TH STREET	N 1/8 - 1/4 (0.188 mi.)	E36	47
K AND K PERFORMANCE	2800 13TH STREET	N 1/8 - 1/4 (0.201 mi.)	E39	49
MOSERS AUTO SERVICE	2800 13TH STREET	N 1/8 - 1/4 (0.201 mi.)	E41	51
1325 28TH AVENUE	1325 28TH AVENUE	N 1/8 - 1/4 (0.218 mi.)	E42	51
ASTRO LINCOLN MERCUR	2617 13TH STREET	NNE 1/8 - 1/4 (0.219 mi.)	F45	53
WHITNEY NATIONAL BAN	1300 25TH AVENUE	NE 1/8 - 1/4 (0.230 mi.)	G47	54
AMERIPRIDE SERVICES	1329 29TH AVENUE	NNW 1/8 - 1/4 (0.233 mi.)	H48	54
MACS QUICK STOP	1301 30TH AVENUE	NNW 1/8 - 1/4 (0.234 mi.)	I50	57
AMERIPRIDE LINEN AND	1316 30TH AVENUE	NNW 1/8 - 1/4 (0.239 mi.)	I55	61
FORMER BARRETT CLEAN	2711 14TH STREET	N 1/4 - 1/2 (0.270 mi.)	J63	71
JACK BARRETTS MODERN	2711 14TH STREET	N 1/4 - 1/2 (0.270 mi.)	J64	72
FIRESTONE	1420 25TH AVENUE	NE 1/4 - 1/2 (0.280 mi.)	L70	75
<b>BAY ICE COMPANY, INC</b>	<b>1413 30TH AVENUE</b>	<b>NNW 1/4 - 1/2 (0.310 mi.)</b>	<b>O84</b>	<b>80</b>
HANCOCK BANK	2510 14TH STREET	NNE 1/4 - 1/2 (0.314 mi.)	L88	83
2500 14TH STREET	2500 14TH STREET	NNE 1/4 - 1/2 (0.317 mi.)	L90	84
GULFPORT PAPER	3019 15TH STREET	NNW 1/4 - 1/2 (0.366 mi.)	O112	89
SALVAGE NINE	2317 14TH STREET	NE 1/4 - 1/2 (0.418 mi.)	S120	96
JOSEPH T JONES BUILD	1422 23RD AVENUE	NE 1/4 - 1/2 (0.449 mi.)	T123	103
<b>GULFPORT, MS, CITY O</b>	<b>2309 15TH STREET</b>	<b>NE 1/4 - 1/2 (0.470 mi.)</b>	<b>T124</b>	<b>103</b>
GULFPORT CENTRAL FIR	2309 15TH STREET	NE 1/4 - 1/2 (0.470 mi.)	T126	105
GULFPORT POLICE OPER	1520 23RD AVENUE	NE 1/4 - 1/2 (0.496 mi.)	V133	110
<u>Lower Elevation</u>	<u>Address</u>	<u>Direction / Distance</u>	<u>Map ID</u>	<u>Page</u>
OLD COPA CASINO	777 COPA BOULEVARD	SSE 0 - 1/8 (0.119 mi.)	6	12

ASBESTOS: A listing of Air Division Asbestos Branch projects.

A review of the ASBESTOS list, as provided by EDR, and dated 06/27/2015 has revealed that there are 3 ASBESTOS sites within approximately 0.5 miles of the target property.

<u>Equal/Higher Elevation</u>	<u>Address</u>	<u>Direction / Distance</u>	<u>Map ID</u>	<u>Page</u>
BALCH & BINGHAM, LLP AI ID: 67284	1314 25TH STREET	NE 1/8 - 1/4 (0.234 mi.)	G53	59
MDOT HARRISON COUNTY AI ID: 38685	1401 28TH AVENUE	N 1/4 - 1/2 (0.271 mi.)	K66	72
HANCOCK BANK AI ID: 26149	2510 14TH STREET	NNE 1/4 - 1/2 (0.314 mi.)	L85	81

## EXECUTIVE SUMMARY

### EDR HIGH RISK HISTORICAL RECORDS

#### ***EDR Exclusive Records***

EDR MGP: The EDR Proprietary Manufactured Gas Plant Database includes records of coal gas plants (manufactured gas plants) compiled by EDR's researchers. Manufactured gas sites were used in the United States from the 1800's to 1950's to produce a gas that could be distributed and used as fuel. These plants used whale oil, rosin, coal, or a mixture of coal, oil, and water that also produced a significant amount of waste. Many of the byproducts of the gas production, such as coal tar (oily waste containing volatile and non-volatile chemicals), sludges, oils and other compounds are potentially hazardous to human health and the environment. The byproduct from this process was frequently disposed of directly at the plant site and can remain or spread slowly, serving as a continuous source of soil and groundwater contamination.

A review of the EDR MGP list, as provided by EDR, has revealed that there is 1 EDR MGP site within approximately 1.5 miles of the target property.

<u>Equal/Higher Elevation</u>	<u>Address</u>	<u>Direction / Distance</u>	<u>Map ID</u>	<u>Page</u>
GULF CITIES GAS CO	23RD AVE	NE 1/2 - 1 (0.523 mi.)	X137	114

EDR US Hist Auto Stat: EDR has searched selected national collections of business directories and has collected listings of potential gas station/filling station/service station sites that were available to EDR researchers. EDR's review was limited to those categories of sources that might, in EDR's opinion, include gas station/filling station/service station establishments. The categories reviewed included, but were not limited to gas, gas station, gasoline station, filling station, auto, automobile repair, auto service station, service station, etc. This database falls within a category of information EDR classifies as "High Risk Historical Records", or HRHR. EDR's HRHR effort presents unique and sometimes proprietary data about past sites and operations that typically create environmental concerns, but may not show up in current government records searches.

A review of the EDR US Hist Auto Stat list, as provided by EDR, has revealed that there are 12 EDR US Hist Auto Stat sites within approximately 0.75 miles of the target property.

<u>Equal/Higher Elevation</u>	<u>Address</u>	<u>Direction / Distance</u>	<u>Map ID</u>	<u>Page</u>
Not reported	1119 30TH AVE	NW 1/8 - 1/4 (0.145 mi.)	D27	38
Not reported	1223 30TH AVE	NW 1/8 - 1/4 (0.180 mi.)	D34	44
Not reported	1420 25TH AVE	NE 1/4 - 1/2 (0.280 mi.)	L73	77
Not reported	2510 16TH ST	NNE 1/4 - 1/2 (0.389 mi.)	118	93
Not reported	2603 17TH ST	NNE 1/4 - 1/2 (0.493 mi.)	127	106
Not reported	2201 14TH ST	ENE 1/4 - 1/2 (0.495 mi.)	U130	107
Not reported	3317 15TH ST	NW 1/4 - 1/2 (0.498 mi.)	134	111
Not reported	1809 25TH AVE	NNE 1/2 - 1 (0.585 mi.)	Y143	119
Not reported	2120 15TH ST	NE 1/2 - 1 (0.589 mi.)	Z145	121
Not reported	1814 33RD AVE	NNW 1/2 - 1 (0.666 mi.)	AB157	137
Not reported	2407 19TH ST	NNE 1/2 - 1 (0.674 mi.)	AC159	139
Not reported	3820 W RAILROAD ST	W 1/2 - 1 (0.700 mi.)	AD162	141

## EXECUTIVE SUMMARY

EDR US Hist Cleaners: EDR has searched selected national collections of business directories and has collected listings of potential dry cleaner sites that were available to EDR researchers. EDR's review was limited to those categories of sources that might, in EDR's opinion, include dry cleaning establishments. The categories reviewed included, but were not limited to dry cleaners, cleaners, laundry, laundromat, cleaning/laundry, wash & dry etc. This database falls within a category of information EDR classifies as "High Risk Historical Records", or HRHR. EDR's HRHR effort presents unique and sometimes proprietary data about past sites and operations that typically create environmental concerns, but may not show up in current government records searches.

A review of the EDR US Hist Cleaners list, as provided by EDR, has revealed that there are 8 EDR US Hist Cleaners sites within approximately 0.75 miles of the target property.

<u>Equal/Higher Elevation</u>	<u>Address</u>	<u>Direction / Distance</u>	<u>Map ID</u>	<u>Page</u>
Not reported	2711 14TH ST	N 1/4 - 1/2 (0.270 mi.)	J65	72
Not reported	2510 14TH ST	NNE 1/4 - 1/2 (0.314 mi.)	L86	81
Not reported	2501 14TH ST	NNE 1/4 - 1/2 (0.315 mi.)	L89	83
Not reported	1512 30TH AVE	NNW 1/4 - 1/2 (0.377 mi.)	R115	92
Not reported	1518 30TH AVE	NNW 1/4 - 1/2 (0.380 mi.)	R116	92
Not reported	2005 30TH AVE	N 1/2 - 1 (0.724 mi.)	165	144
Not reported	3109 20TH ST	NNW 1/2 - 1 (0.743 mi.)	167	146
Not reported	2415 20TH ST	NNE 1/2 - 1 (0.745 mi.)	168	147

### EDR RECOVERED GOVERNMENT ARCHIVES

#### ***Exclusive Recovered Govt. Archives***

RGA LUST: The EDR Recovered Government Archive Leaking Underground Storage Tank database provides a list of LUST incidents derived from historical databases and includes many records that no longer appear in current government lists. Compiled from Records formerly available from the Department of Environmental Quality in Mississippi.

A review of the RGA LUST list, as provided by EDR, has revealed that there are 17 RGA LUST sites within approximately 0.5 miles of the target property.

<u>Equal/Higher Elevation</u>	<u>Address</u>	<u>Direction / Distance</u>	<u>Map ID</u>	<u>Page</u>
JR. FOOD MART #39 Facility ID: 5396	2605 WEST BEACH BLVD	ENE 0 - 1/8 (0.120 mi.)	C7	13
JR FOOD MART #39 Facility ID: 5396	2605 WEST BEACH BOUL	ENE 0 - 1/8 (0.120 mi.)	C8	13
JR FOOD MART #39 Facility ID: 5396	2605 WEST BEACH BLVD	ENE 0 - 1/8 (0.120 mi.)	C9	13
JR. FOOD MART 39 Facility ID: 5396	2605 WEST BEACH BLVD	ENE 0 - 1/8 (0.120 mi.)	C10	13
BARON #75 Facility ID: 752	2501 WEST BEACH BOUL	ENE 1/8 - 1/4 (0.134 mi.)	C16	29
FORMER BARON #75 Facility ID: 752	2501 WEST BEACH BOUL	ENE 1/8 - 1/4 (0.134 mi.)	C17	29
FAST TRAC #23 Facility ID: 4251	1119 30TH AVENUE	NW 1/8 - 1/4 (0.145 mi.)	D22	33
30TH AVENUE CHEVRON	1119 30TH AVENUE	NW 1/8 - 1/4 (0.145 mi.)	D23	33



## EXECUTIVE SUMMARY

Facility ID: 4251					
30TH AVE CHEVRON FOO Facility ID: 4251	1119 30TH AVENUE	NW 1/8 - 1/4 (0.145 mi.)	D24	33	
SWIFTY SERVE #527 Facility ID: 4251	1119 30TH AVENUE	NW 1/8 - 1/4 (0.145 mi.)	D25	34	
P T DELI # 1 Facility ID: 168	3000 12TH STREET	NW 1/8 - 1/4 (0.169 mi.)	D29	39	
P T DELI #1 Facility ID: 168	3000 12TH STREET	NW 1/8 - 1/4 (0.169 mi.)	D32	43	
COASTAL ENERGY CO OF Facility ID: 168	3000 12TH STREET	NW 1/8 - 1/4 (0.169 mi.)	D33	44	
COLONIAL TRAILWAYS B Facility ID: 1684	2805 13TH STREET	N 1/8 - 1/4 (0.188 mi.)	E37	47	
MAC'S QUICK STOP Facility ID: 4478	1301 30TH AVENUE	NNW 1/8 - 1/4 (0.234 mi.)	I51	57	
FIRESTONE STORE #050 Facility ID: 2008	1420 25TH AVENUE	NE 1/4 - 1/2 (0.280 mi.)	L69	74	
DOWNTOWN SERVICE STA Facility ID: 10749	2201 14TH STREET	ENE 1/4 - 1/2 (0.495 mi.)	U129	107	

## EXECUTIVE SUMMARY

Due to poor or inadequate address information, the following sites were not mapped. Count: 2 records.

<u>Site Name</u>	<u>Database(s)</u>
MAJIK MARKET #04486	LUST, UST
MITCHELL COMPANY INC, THE, THE HAM	FINDS

# OVERVIEW MAP - 4407765.2S

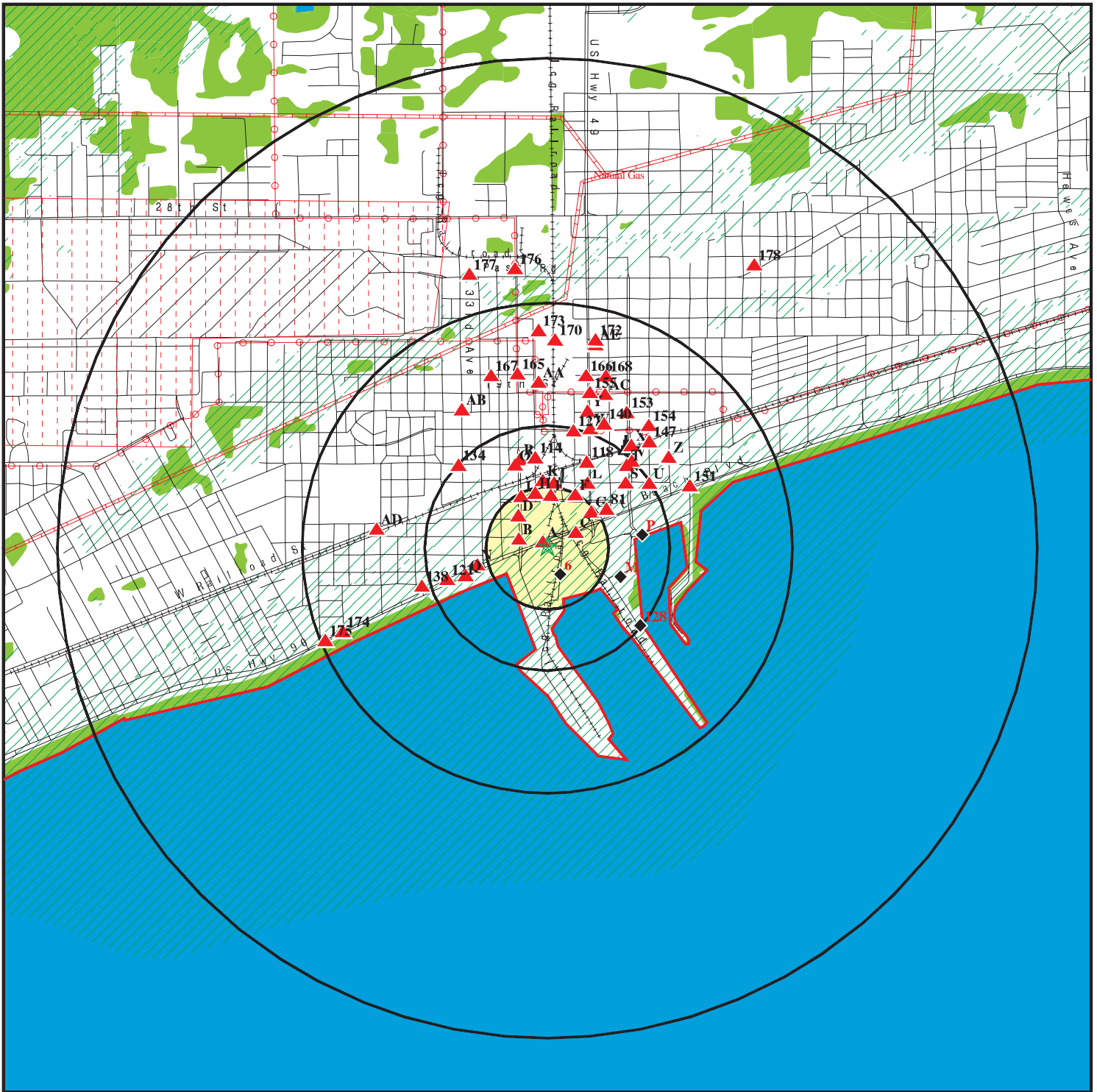

- ★ Target Property
- ▲ Sites at elevations higher than or equal to the target property
- ◆ Sites at elevations lower than the target property
- ▲ Manufactured Gas Plants
- National Priority List Sites
- Dept. Defense Sites



- Indian Reservations BIA
- ▬ County Boundary
- ▬ Power transmission lines
- ▬ Pipelines
- ▨ 100-year flood zone
- ▨ 500-year flood zone
- National Wetland Inventory



This report includes Interactive Map Layers to display and/or hide map information. The legend includes only those icons for the default map view.

SITE NAME: Port of Gulfport  
 ADDRESS: West Beach Boulevard  
 Gulfport MS 39501  
 LAT/LONG: 30.3643 / 89.0958

CLIENT: Atkins  
 CONTACT: Brad Bayne  
 INQUIRY #: 4407765.2s  
 DATE: September 10, 2015 5:18 pm

# DETAIL MAP - 4407765.2S

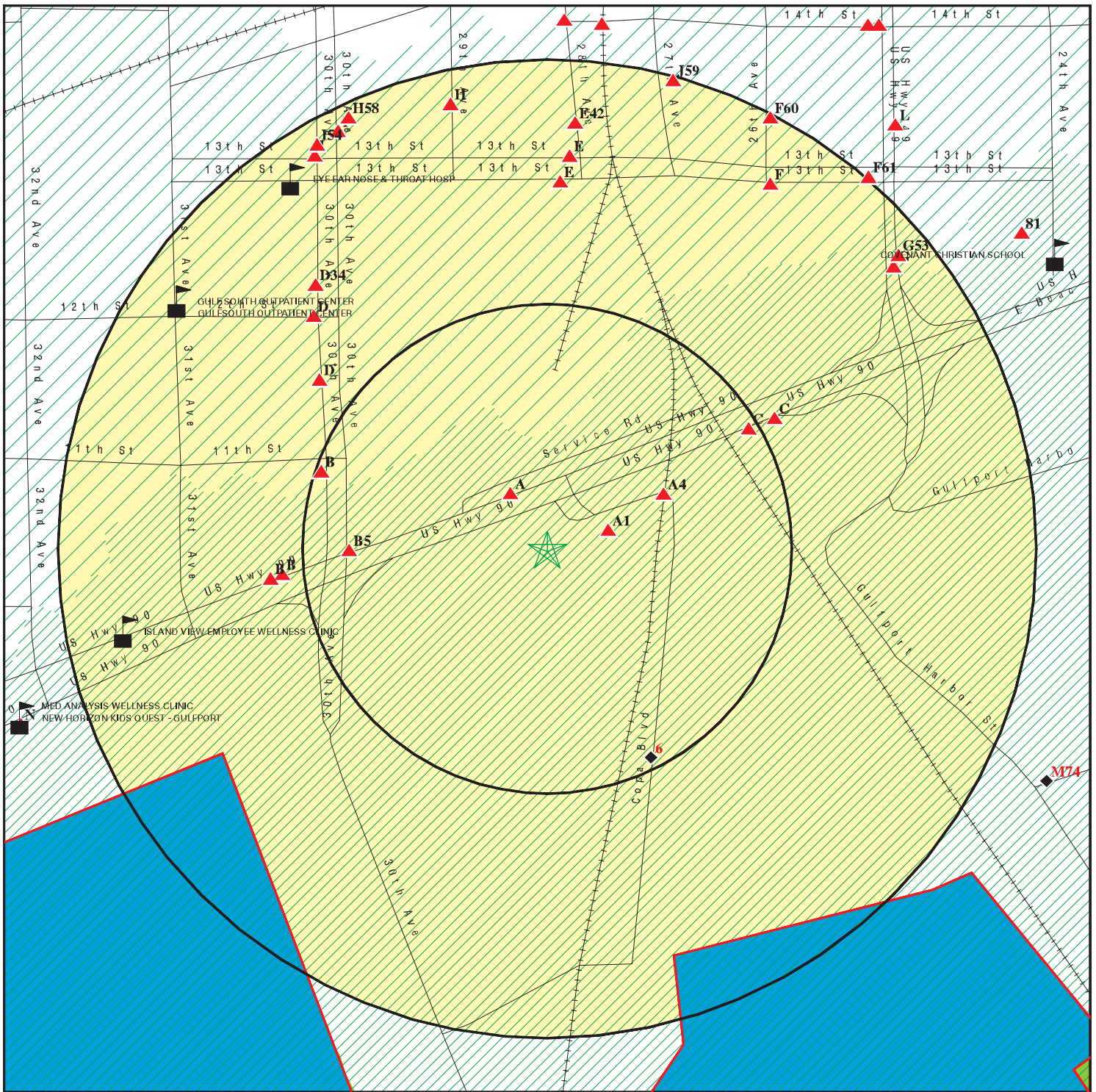

- ★ Target Property
- ▲ Sites at elevations higher than or equal to the target property
- ◆ Sites at elevations lower than the target property
- ▲ Manufactured Gas Plants
- Sensitive Receptors
- National Priority List Sites
- Dept. Defense Sites
- Indian Reservations BIA
- ▲ County Boundary
- 100-year flood zone
- 500-year flood zone
- National Wetland Inventory

This report includes Interactive Map Layers to display and/or hide map information. The legend includes only those icons for the default map view.

SITE NAME: Port of Gulfport  
 ADDRESS: West Beach Boulevard  
 Gulfport MS 39501  
 LAT/LONG: 30.3643 / 89.0958

CLIENT: Atkins  
 CONTACT: Brad Bayne  
 INQUIRY #: 4407765.2s  
 DATE: September 10, 2015 5:21 pm

## MAP FINDINGS SUMMARY

Database	Search Distance (Miles)	Target Property	< 1/8	1/8 - 1/4	1/4 - 1/2	1/2 - 1	> 1	Total Plotted
<b>STANDARD ENVIRONMENTAL RECORDS</b>								
<b><i>Federal NPL site list</i></b>								
NPL	1.500		0	0	0	0	0	0
Proposed NPL	1.500		0	0	0	0	0	0
NPL LIENS	0.500		0	0	0	NR	NR	0
<b><i>Federal Delisted NPL site list</i></b>								
Delisted NPL	1.500		0	0	0	0	0	0
<b><i>Federal CERCLIS list</i></b>								
FEDERAL FACILITY	1.000		0	0	0	0	NR	0
CERCLIS	1.000		0	0	0	0	NR	0
<b><i>Federal CERCLIS NFRAP site List</i></b>								
CERC-NFRAP	1.000		0	0	0	0	NR	0
<b><i>Federal RCRA CORRACTS facilities list</i></b>								
CORRACTS	1.500		0	0	0	0	0	0
<b><i>Federal RCRA non-CORRACTS TSD facilities list</i></b>								
RCRA-TSDF	1.000		0	0	0	0	NR	0
<b><i>Federal RCRA generators list</i></b>								
RCRA-LQG	0.750		0	0	0	0	NR	0
RCRA-SQG	0.750		0	0	0	0	NR	0
RCRA-CESQG	0.750		1	4	2	9	NR	16
<b><i>Federal institutional controls / engineering controls registries</i></b>								
LUCIS	1.000		0	0	0	0	NR	0
US ENG CONTROLS	1.000		0	0	0	0	NR	0
US INST CONTROL	1.000		0	0	0	0	NR	0
<b><i>Federal ERNS list</i></b>								
ERNS	0.500		2	1	30	NR	NR	33
<b><i>State- and tribal - equivalent CERCLIS</i></b>								
SHWS	1.500		1	4	5	6	3	19
<b><i>State and tribal landfill and/or solid waste disposal site lists</i></b>								
SWF/LF	1.000		0	0	0	0	NR	0
DEBRIS	1.000		0	0	0	0	NR	0
<b><i>State and tribal leaking storage tank lists</i></b>								
LUST	1.000		2	5	4	5	NR	16
INDIAN LUST	1.000		0	0	0	0	NR	0
<b><i>State and tribal registered storage tank lists</i></b>								
FEMA UST	0.750		0	0	0	0	NR	0

## MAP FINDINGS SUMMARY

Database	Search Distance (Miles)	Target Property	< 1/8	1/8 - 1/4	1/4 - 1/2	1/2 - 1	> 1	Total Plotted
UST	0.750		4	8	10	9	NR	31
AST	0.750		0	0	0	1	NR	1
INDIAN UST	0.750		0	0	0	0	NR	0
<b>State and tribal institutional control / engineering control registries</b>								
ENG CONTROLS	1.000		0	0	0	0	NR	0
INST CONTROL	1.000		0	0	0	0	NR	0
<b>State and tribal voluntary cleanup sites</b>								
INDIAN VCP	1.000		0	0	0	0	NR	0
VCP	1.000		0	1	0	0	NR	1
<b>State and tribal Brownfields sites</b>								
BROWNFIELDS	1.000		0	0	0	0	NR	0
<b>ADDITIONAL ENVIRONMENTAL RECORDS</b>								
<b>Local Brownfield lists</b>								
US BROWNFIELDS	1.000		0	1	1	1	NR	3
<b>Local Lists of Landfill / Solid Waste Disposal Sites</b>								
SWTIRE	1.000		0	0	0	0	NR	0
SWRCY	1.000		0	0	0	1	NR	1
INDIAN ODI	1.000		0	0	0	0	NR	0
ODI	1.000		0	0	0	0	NR	0
DEBRIS REGION 9	1.000		0	0	0	0	NR	0
<b>Local Lists of Hazardous waste / Contaminated Sites</b>								
US HIST CDL	0.500		0	0	0	NR	NR	0
US CDL	0.500		0	0	0	NR	NR	0
<b>Local Land Records</b>								
LIENS 2	0.500		0	0	0	NR	NR	0
<b>Records of Emergency Release Reports</b>								
HMIRS	0.500		0	0	0	NR	NR	0
<b>Other Ascertainable Records</b>								
RCRA NonGen / NLR	0.750		0	1	0	3	NR	4
FUDS	1.500		0	0	0	0	0	0
DOD	1.500		0	0	0	1	0	1
SCRD DRYCLEANERS	1.000		0	0	0	0	NR	0
US FIN ASSUR	0.500		0	0	0	NR	NR	0
EPA WATCH LIST	0.500		0	0	0	NR	NR	0
2020 COR ACTION	0.750		0	0	0	0	NR	0
TSCA	0.500		0	0	0	NR	NR	0
TRIS	0.500		0	0	0	NR	NR	0

## MAP FINDINGS SUMMARY

Database	Search Distance (Miles)	Target Property	< 1/8	1/8 - 1/4	1/4 - 1/2	1/2 - 1	> 1	Total Plotted
SSTS	0.500		0	0	0	NR	NR	0
ROD	1.500		0	0	0	0	0	0
RMP	0.500		0	0	0	NR	NR	0
RAATS	0.500		0	0	0	NR	NR	0
PRP	0.500		0	0	0	NR	NR	0
PADS	0.500		0	0	0	NR	NR	0
ICIS	0.500		1	0	2	NR	NR	3
FTTS	0.500		0	0	0	NR	NR	0
MLTS	0.500		0	0	0	NR	NR	0
COAL ASH DOE	0.500		0	0	0	NR	NR	0
COAL ASH EPA	1.000		0	0	0	0	NR	0
PCB TRANSFORMER	0.500		0	0	0	NR	NR	0
RADINFO	0.500		0	0	0	NR	NR	0
HIST FTTS	0.500		0	0	0	NR	NR	0
DOT OPS	0.500		0	0	0	NR	NR	0
CONSENT	1.500		0	0	0	0	0	0
INDIAN RESERV	1.500		0	0	0	0	0	0
UMTRA	1.000		0	0	0	0	NR	0
LEAD SMELTERS	0.500		0	0	0	NR	NR	0
US AIRS	0.500		0	0	0	NR	NR	0
US MINES	0.750		0	0	0	0	NR	0
FINDS	0.500		4	13	12	NR	NR	29
AIRS	0.500		0	0	0	NR	NR	0
ASBESTOS	0.500		0	1	2	NR	NR	3
DRYCLEANERS	0.750		0	0	0	0	NR	0
NPDES	0.500		0	0	0	NR	NR	0
PERMITS	TP		NR	NR	NR	NR	NR	0
UIC	0.500		0	0	0	NR	NR	0

### EDR HIGH RISK HISTORICAL RECORDS

#### *EDR Exclusive Records*

EDR MGP	1.500		0	0	0	1	0	1
EDR US Hist Auto Stat	0.750		0	2	5	5	NR	12
EDR US Hist Cleaners	0.750		0	0	5	3	NR	8

### EDR RECOVERED GOVERNMENT ARCHIVES

#### *Exclusive Recovered Govt. Archives*

RGA HWS	0.500		0	0	0	NR	NR	0
RGA LF	0.500		0	0	0	NR	NR	0
RGA LUST	0.500		4	11	2	NR	NR	17

- Totals --		0	19	52	80	45	3	199
-------------	--	---	----	----	----	----	---	-----

#### NOTES:

TP = Target Property

NR = Not Requested at this Search Distance

Sites may be listed in more than one database



Map ID  
Direction  
Distance  
Elevation

MAP FINDINGS

Site

Database(s)

EDR ID Number  
EPA ID Number

**DOD** NAVAL CONSTRUCTION BATALION CENTER  
**Region**  
**NNW** NAVAL CONSTRUCTION BATALL (County), MS  
**1/2-1**  
**5245 ft.**

**DOD** CUSA147290  
N/A

DOD:  
Feature 1: Navy DOD  
Feature 2: Not reported  
Feature 3: Not reported  
URL: Not reported  
Name 1: Naval Construction Battalion Center  
Name 2: Not reported  
Name 3: Not reported  
State: MS  
DOD Site: Yes  
Tile name: MSHARRISON

**A1** SEARS FACILITY #7456  
**ENE**  
**< 1/8**  
**0.033 mi.**  
**173 ft.**  
**Site 1 of 4 in cluster A**

**SHWS** S103920782  
N/A

**Relative:** SHWS:  
**Higher** Lat/Long (dms): 30 21 52 / 89 5 43  
Site Size (acres): Not reported  
**Actual:** EPA ID: MSR000000950  
**10 ft.** Project Manager: Not reported  
**Status:** **Inactive**  
State No Further Action Date: Not reported  
Federal: Not reported  
Federal No Further Action Date: Not reported  
Soil Contamination: Yes  
Surface Water Contamination: No  
Ground Water Contamination: No  
Remediation Type: Not reported  
Surface Water Remediation: Not reported  
GW Remediation Type: Not reported  
Maj. Contaminant: TPH  
High Concentration: 2.04E+04  
High Concentration Units: mg/kg  
Institutional Control: Not reported  
Engineering Control: Not reported  
Voluntary Cleanups: Not reported

**A2** SEARS #7456  
**NNW** 2818 WEST BEACH BOULEVARD  
**< 1/8** GULFPORT, MS 39501  
**0.034 mi.**  
**180 ft.** **Site 2 of 4 in cluster A**

**UST** U003775106  
N/A

**Relative:** UST:  
**Higher** Facility ID: 11775  
Facility Status: Inactive  
**Actual:** Latitude: 30 21' 54.0000"  
**12 ft.** Longitude: 89 5' 41.0000"  
Permanently Out of Use Tanks: 9

Map ID  
Direction  
Distance  
Elevation

MAP FINDINGS

Site

Database(s)

EDR ID Number  
EPA ID Number

SEARS #7456 (Continued)

U003775106

Active Tanks: 0  
AIID: 30997  
Owner Name: Sears Roebuck & Company  
Owner Address: 3333 Beverly Road Dept 824c, A2-158b  
Owner Tele: (847)286-5530

Tank:

Tank No: 1  
Tank ID: 29595  
**Tank Status: Permanently Out of Use**  
Tank Capacity: 4000  
Date Installed: 01/01/1952  
Substance: Used Oil  
Reported Release: Not reported  
Close Type: Closed  
Date Removed: 04/18/1996  
Close Type: 04/18/1996  
Tank Material: Unknown  
2nd Containmnt: None  
Tank Lead Detection: N/A  
Overfill Protection: No  
Spill Prevention: No

Tank:

Tank No: 2  
Tank ID: 29596  
**Tank Status: Permanently Out of Use**  
Tank Capacity: 2500  
Date Installed: 01/01/1952  
Substance: Used Oil  
Reported Release: Not reported  
Close Type: Closed  
Date Removed: 04/18/1996  
Close Type: 04/18/1996  
Tank Material: Unknown  
2nd Containmnt: None  
Tank Lead Detection: N/A  
Overfill Protection: No  
Spill Prevention: No

Tank:

Tank No: 3  
Tank ID: 29597  
**Tank Status: Permanently Out of Use**  
Tank Capacity: 2500  
Date Installed: 01/01/1952  
Substance: Used Oil  
Reported Release: Not reported  
Close Type: Closed  
Date Removed: 04/18/1996  
Close Type: 04/18/1996  
Tank Material: Unknown  
2nd Containmnt: None  
Tank Lead Detection: N/A

Map ID  
Direction  
Distance  
Elevation

MAP FINDINGS

Site

Database(s)

EDR ID Number  
EPA ID Number

SEARS #7456 (Continued)

U003775106

Overfill Protection: No  
Spill Prevention: No

Tank:

Tank No: 4  
Tank ID: 29598  
**Tank Status: Permanently Out of Use**  
Tank Capacity: 2500  
Date Installed: 01/01/1952  
Substance: Used Oil  
Reported Release: Not reported  
Close Type: Closed  
Date Removed: 04/18/1996  
Close Type: 04/18/1996  
Tank Material: Unknown  
2nd Containmnt: None  
Tank Lead Detection: N/A  
Overfill Protection: No  
Spill Prevention: No

Tank:

Tank No: 5  
Tank ID: 29599  
**Tank Status: Permanently Out of Use**  
Tank Capacity: 1000  
Date Installed: 01/01/1952  
Substance: Used Oil  
Reported Release: Not reported  
Close Type: Closed  
Date Removed: 01/01/1993  
Close Type: 04/18/1996  
Tank Material: Unknown  
2nd Containmnt: None  
Tank Lead Detection: N/A  
Overfill Protection: No  
Spill Prevention: No

Tank:

Tank No: 6  
Tank ID: 29600  
**Tank Status: Permanently Out of Use**  
Tank Capacity: 6000  
Date Installed: Not reported  
Substance: Gasoline  
Reported Release: Not reported  
Close Type: Closed  
Date Removed: 04/24/1996  
Close Type: 04/24/1996  
Tank Material: Unknown  
2nd Containmnt: None  
Tank Lead Detection: N/A  
Overfill Protection: No  
Spill Prevention: No

Map ID  
Direction  
Distance  
Elevation

MAP FINDINGS

Site

Database(s)

EDR ID Number  
EPA ID Number

SEARS #7456 (Continued)

U003775106

Pipe:

Tank No: 6  
Tank Id: 29600  
Pipe Id: 6  
Pipe Status: Permanently Out of Use  
Type Of Closure: Closed  
Pipe Material Construction: Unknown  
Secondary Pipe Material: None  
Piping Type: N/A  
Pipe Leak Detection: Not Listed

Tank:

Tank No: 7  
Tank ID: 29601  
**Tank Status: Permanently Out of Use**  
Tank Capacity: 6000  
Date Installed: Not reported  
Substance: Gasoline  
Reported Release: Not reported  
Close Type: Closed  
Date Removed: 05/06/1996  
Close Type: 05/06/1996  
Tank Material: Unknown  
2nd Containmnt: None  
Tank Lead Detection: N/A  
Overfill Protection: No  
Spill Prevention: No

Pipe:

Tank No: 7  
Tank Id: 29601  
Pipe Id: 7  
Pipe Status: Permanently Out of Use  
Type Of Closure: Closed  
Pipe Material Construction: Unknown  
Secondary Pipe Material: None  
Piping Type: N/A  
Pipe Leak Detection: Not Listed

Tank:

Tank No: 8  
Tank ID: 29602  
**Tank Status: Permanently Out of Use**  
Tank Capacity: 6000  
Date Installed: Not reported  
Substance: Gasoline  
Reported Release: Not reported  
Close Type: Closed  
Date Removed: 05/09/1996  
Close Type: 05/09/1996  
Tank Material: Unknown  
2nd Containmnt: None

Map ID  
Direction  
Distance  
Elevation

MAP FINDINGS

Site

Database(s)

EDR ID Number  
EPA ID Number

**SEARS #7456 (Continued)**

**U003775106**

Tank Lead Detection: N/A  
Overfill Protection: No  
Spill Prevention: No

Pipe:

Tank No: 8  
Tank Id: 29602  
Pipe Id: 8  
Pipe Status: Permanently Out of Use  
Type Of Closure: Closed  
Pipe Material Construction: Unknown  
Secondary Pipe Material: None  
Piping Type: N/A  
Pipe Leak Detection: Not Listed

Tank:

Tank No: 9  
Tank ID: 29603  
**Tank Status: Permanently Out of Use**  
Tank Capacity: 6000  
Date Installed: Not reported  
Substance: Gasoline  
Reported Release: Not reported  
Close Type: Closed  
Date Removed: 05/09/1996  
Close Type: 05/09/1996  
Tank Material: Unknown  
2nd Containmnt: None  
Tank Lead Detection: N/A  
Overfill Protection: No  
Spill Prevention: No

Pipe:

Tank No: 9  
Tank Id: 29603  
Pipe Id: 9  
Pipe Status: Permanently Out of Use  
Type Of Closure: Closed  
Pipe Material Construction: Unknown  
Secondary Pipe Material: None  
Piping Type: N/A  
Pipe Leak Detection: Not Listed

A3  
NNW  
< 1/8  
0.034 mi.  
180 ft.

**SEARS NUMBER 7456  
2818 WEST BEACH BOULEVARD  
GULFPORT, MS 39501**

**FINDS 1016008377  
N/A**

**Site 3 of 4 in cluster A**

**Relative:  
Higher**

FINDS:

Registry ID: 110044499423

**Actual:  
12 ft.**

Environmental Interest/Information System  
MS-ENSITE (Mississippi - Tools For Environmental Management And

Map ID  
 Direction  
 Distance  
 Elevation

MAP FINDINGS

Site

Database(s)

EDR ID Number  
 EPA ID Number

**SEARS NUMBER 7456 (Continued)**

**1016008377**

Protection Organizations). Mississippi Department of Environmental Quality (MDEQ) Office of Pollution Control's (OPC) maintains enSite. It is the electronic Environmental Site Information System that regulates compliance assurance, permitting, activity tracking, and maintenance of a single agency interest-link to definition master file.

**A4**  
**ENE**  
 < 1/8  
 0.066 mi.  
 348 ft.

**877 COPA BLVD**  
**GULFPORT, MS 39502**  
  
 Site 4 of 4 in cluster A

**ERNS 96495694**  
 N/A

**Relative:**  
**Higher**

[Click this hyperlink](#) while viewing on your computer to access additional ERNS detail in the EDR Site Report.

**Actual:**  
 10 ft.  
**B5**  
**West**  
 < 1/8  
 0.101 mi.  
 534 ft.

**1000 30TH AVE**  
**GULFPORT, MS**  
  
 Site 1 of 7 in cluster B

**ERNS 2011983993**  
 N/A

**Relative:**  
**Higher**

[Click this hyperlink](#) while viewing on your computer to access additional ERNS detail in the EDR Site Report.

**Actual:**  
 14 ft.  
**6**  
**SSE**  
 < 1/8  
 0.119 mi.  
 629 ft.

**OLD COPA CASINO**  
**777 COPA BOULEVARD**  
**GULFPORT, MS 39501**

**FINDS 1016019581**  
 N/A

**Relative:**  
**Lower**

FINDS:

Registry ID: 110044547657

**Actual:**  
 7 ft.

Environmental Interest/Information System

MS-ENSITE (Mississippi - Tools For Environmental Management And Protection Organizations). Mississippi Department of Environmental Quality (MDEQ) Office of Pollution Control's (OPC) maintains enSite. It is the electronic Environmental Site Information System that regulates compliance assurance, permitting, activity tracking, and maintenance of a single agency interest-link to definition master file.

MAP FINDINGS

Map ID Direction Distance Elevation	Site	Database(s)	EDR ID Number EPA ID Number
<b>C7</b> <b>ENE</b> <b>&lt; 1/8</b> <b>0.120 mi.</b> <b>634 ft.</b>	<b>JR. FOOD MART #39</b> <b>2605 WEST BEACH BLVD.</b> <b>GULFPORT, MS</b>  <b>Site 1 of 9 in cluster C</b>  Relative: <b>Higher</b>	<b>RGA LUST</b>	<b>S116271341</b> <b>N/A</b>
	RGA LUST: 1996 JR. FOOD MART #39 2605 WEST BEACH BLVD.		
<b>Actual:</b> <b>11 ft.</b>			
<b>C8</b> <b>ENE</b> <b>&lt; 1/8</b> <b>0.120 mi.</b> <b>634 ft.</b>	<b>JR FOOD MART #39</b> <b>2605 WEST BEACH BOULEVARD</b> <b>GULFPORT, MS</b>  <b>Site 2 of 9 in cluster C</b>  Relative: <b>Higher</b>	<b>RGA LUST</b>	<b>S116271320</b> <b>N/A</b>
	RGA LUST: 2012 JR FOOD MART #39 2605 WEST BEACH BOULEVARD 2011 JR FOOD MART #39 2605 WEST BEACH BOULEVARD 2010 JR FOOD MART #39 2605 WEST BEACH BOULEVARD 2009 JR FOOD MART #39 2605 WEST BEACH BOULEVARD		
<b>Actual:</b> <b>11 ft.</b>			
<b>C9</b> <b>ENE</b> <b>&lt; 1/8</b> <b>0.120 mi.</b> <b>634 ft.</b>	<b>JR FOOD MART #39</b> <b>2605 WEST BEACH BLVD</b> <b>GULFPORT, MS</b>  <b>Site 3 of 9 in cluster C</b>  Relative: <b>Higher</b>	<b>RGA LUST</b>	<b>S116271319</b> <b>N/A</b>
	RGA LUST: 2008 JR FOOD MART #39 2605 WEST BEACH BLVD 2007 JR FOOD MART #39 2605 WEST BEACH BLVD 2006 JR FOOD MART #39 2605 WEST BEACH BLVD 2005 JR FOOD MART #39 2605 WEST BEACH BLVD 2004 JR FOOD MART #39 2605 WEST BEACH BLVD 2003 JR FOOD MART #39 2605 WEST BEACH BLVD 2002 JR FOOD MART #39 2605 WEST BEACH BLVD 2001 JR FOOD MART #39 2605 WEST BEACH BLVD 2000 JR FOOD MART #39 2605 WEST BEACH BLVD 1999 JR FOOD MART #39 2605 WEST BEACH BLVD 1998 JR FOOD MART #39 2605 WEST BEACH BLVD 1997 JR FOOD MART #39 2605 WEST BEACH BLVD		
<b>Actual:</b> <b>11 ft.</b>			
<b>C10</b> <b>ENE</b> <b>&lt; 1/8</b> <b>0.120 mi.</b> <b>634 ft.</b>	<b>JR. FOOD MART 39</b> <b>2605 WEST BEACH BLVD.</b> <b>GULFPORT, MS</b>  <b>Site 4 of 9 in cluster C</b>  Relative: <b>Higher</b>	<b>RGA LUST</b>	<b>S116271348</b> <b>N/A</b>
	RGA LUST: 1996 JR. FOOD MART 39 2605 WEST BEACH BLVD.		
<b>Actual:</b> <b>11 ft.</b>			



Map ID  
Direction  
Distance  
Elevation

MAP FINDINGS

Site

Database(s)

EDR ID Number  
EPA ID Number

C11  
ENE  
< 1/8  
0.120 mi.  
634 ft.

JR FOOD MART #39  
2605 WEST BEACH BOULEVARD  
GULFPORT, MS 39501  
Site 5 of 9 in cluster C

LUST U001295966  
UST N/A

Relative:  
Higher

Facility Id: 5396  
Facility Status: Inactive  
Lust Status: Closed  
AIIID: 31070  
Event #: 1  
Project Manager: Larry Flynt  
Date Of Report: 01/01/1992  
Trust Fund Status: NTFE  
Confirmed On: 01/01/1992  
NFA Date: 01/12/1995

Actual:  
11 ft.

Facility Id: 5396  
Facility Status: Inactive  
Lust Status: Closed  
AIIID: 31070  
Event #: 2  
Project Manager: Larry Flynt  
Date Of Report: 03/01/1996  
Trust Fund Status: EUD  
Confirmed On: 03/01/1996  
NFA Date: 07/18/1996

Facility Id: 5396  
Facility Status: Inactive  
Lust Status: Open  
AIIID: 31070  
Event #: 3  
Project Manager: Dan Harper  
Date Of Report: 04/01/2011  
Trust Fund Status: STFS  
Confirmed On: 04/01/2011  
NFA Date: Not reported

UST:

Facility ID: 5396  
Facility Status: Inactive  
Latitude: 30 21' 54.4400"  
Longitude: 89 5' 36.8300"  
Permanently Out of Use Tanks: 4  
Active Tanks: 0  
AIIID: 31070  
Owner Name: Not reported  
Owner Address: Not reported  
Owner Tele: Not reported

Tank:

Tank No: 1  
Tank ID: 13594  
Tank Status: Permanently Out of Use  
Tank Capacity: 10000  
Date Installed: 01/01/1974

Map ID  
Direction  
Distance  
Elevation

MAP FINDINGS

Site

Database(s)

EDR ID Number  
EPA ID Number

JR FOOD MART #39 (Continued)

U001295966

Substance: Gasoline  
Reported Release: Yes  
Close Type: Closed  
Date Removed: 06/24/1996  
Close Type: 06/25/1996  
Tank Material: Asphalt Coated or Bare Steel  
2nd Containmnt: None  
Tank Lead Detection: Groundwater/Vapor Monitoring  
Overfill Protection: No  
Spill Prevention: No

Pipe:

Tank No: 1  
Tank Id: 13594  
Pipe Id: 1  
Pipe Status: Permanently Out of Use  
Type Of Closure: Closed  
Pipe Material Construction: Bare/Galvanized Steel  
Secondary Pipe Material: None  
Piping Type: Pressurized  
Pipe Leak Detection: Groundwater/Vapor Monitoring

Tank:

Tank No: 2  
Tank ID: 13595  
**Tank Status: Permanently Out of Use**  
Tank Capacity: 10000  
Date Installed: 01/01/1974  
Substance: Gasoline  
Reported Release: Yes  
Close Type: Closed  
Date Removed: 06/24/1996  
Close Type: 06/25/1996  
Tank Material: Asphalt Coated or Bare Steel  
2nd Containmnt: None  
Tank Lead Detection: Groundwater/Vapor Monitoring  
Overfill Protection: No  
Spill Prevention: No

Pipe:

Tank No: 2  
Tank Id: 13595  
Pipe Id: 2  
Pipe Status: Permanently Out of Use  
Type Of Closure: Closed  
Pipe Material Construction: Bare/Galvanized Steel  
Secondary Pipe Material: None  
Piping Type: Pressurized  
Pipe Leak Detection: Groundwater/Vapor Monitoring

Tank:

Tank No: 3  
Tank ID: 13596

Map ID  
Direction  
Distance  
Elevation

MAP FINDINGS

Site

Database(s)

EDR ID Number  
EPA ID Number

JR FOOD MART #39 (Continued)

U001295966

**Tank Status:** Permanently Out of Use  
Tank Capacity: 10000  
Date Installed: 01/01/1974  
Substance: Gasoline  
Reported Release: Yes  
Close Type: Closed  
Date Removed: 06/24/1996  
Close Type: 06/25/1996  
Tank Material: Asphalt Coated or Bare Steel  
2nd Containmnt: None  
Tank Lead Detection: Groundwater/Vapor Monitoring  
Overfill Protection: No  
Spill Prevention: No

Pipe:  
Tank No: 3  
Tank Id: 13596  
Pipe Id: 3  
Pipe Status: Permanently Out of Use  
Type Of Closure: Closed  
Pipe Material Construction: Bare/Galvanized Steel  
Secondary Pipe Material: None  
Piping Type: Pressurized  
Pipe Leak Detection: Groundwater/Vapor Monitoring

Tank:  
Tank No: 4  
Tank ID: 13597  
**Tank Status:** Permanently Out of Use  
Tank Capacity: 10000  
Date Installed: 01/01/1983  
Substance: Diesel  
Reported Release: Yes  
Close Type: Closed  
Date Removed: 06/24/1996  
Close Type: 06/25/1996  
Tank Material: Asphalt Coated or Bare Steel  
2nd Containmnt: None  
Tank Lead Detection: Groundwater/Vapor Monitoring  
Overfill Protection: No  
Spill Prevention: No

Pipe:  
Tank No: 4  
Tank Id: 13597  
Pipe Id: 4  
Pipe Status: Permanently Out of Use  
Type Of Closure: Closed  
Pipe Material Construction: Bare/Galvanized Steel  
Secondary Pipe Material: None  
Piping Type: Pressurized  
Pipe Leak Detection: Groundwater/Vapor Monitoring

Map ID  
 Direction  
 Distance  
 Elevation

MAP FINDINGS

Site

Database(s)

EDR ID Number  
 EPA ID Number

**C12**  
**ENE**  
 < 1/8  
 0.120 mi.  
 634 ft.

**JR FOOD MART NUMBER 39**  
**2605 WEST BEACH BOULEVARD**  
**GULFPORT, MS 39501**

**FINDS 1016010291**  
**N/A**

**Relative:**  
**Higher**

FINDS:

**Actual:**  
 11 ft.

Registry ID: 110044507478  
 Environmental Interest/Information System  
 MS-ENSITE (Mississippi - Tools For Environmental Management And Protection Organizations). Mississippi Department of Environmental Quality (MDEQ) Office of Pollution Control's (OPC) maintains enSite. It is the electronic Environmental Site Information System that that regulates compliance assurance, permitting, activity tracking, and maintenance of a single agency interest-link to definition master file.

**B13**  
**WNW**  
 < 1/8  
 0.122 mi.  
 645 ft.

**MS STATE PORT AUTHORITY TRUCK STOP**  
**30TH AVE SOUTH OF HIGHWAY US 90**  
**GULFPORT, MS 39502**

**LUST U001298954**  
**UST N/A**

**Relative:**  
**Higher**

Facility Id: 748  
 Facility Status: Inactive  
 Lust Status: Closed  
 AIID: 31015  
 Event #: 1  
 Project Manager: Larry Flynt  
 Date Of Report: 05/20/1992  
 Trust Fund Status: STFS  
 Confirmed On: 05/20/1992  
 NFA Date: 06/29/1992

**Actual:**  
 18 ft.

UST:  
 Facility ID: 748  
 Facility Status: Inactive  
 Latitude: 30 21' 71.0000"  
 Longitude: 89 5' 85.0000"  
 Permanently Out of Use Tanks: 7  
 Active Tanks: 0  
 AIID: 31015  
 Owner Name: MS State Port Authority  
 Owner Address: One Hancock Plaza, Suite 1401  
 Owner Tele: (228)865-4315

Tank:  
 Tank No: 1  
 Tank ID: 1961  
**Tank Status: Permanently Out of Use**  
 Tank Capacity: 6000  
 Date Installed: 01/01/1976  
 Substance: Gasoline  
 Reported Release: Yes  
 Close Type: Closed

Map ID  
Direction  
Distance  
Elevation

MAP FINDINGS

Site

Database(s)

EDR ID Number  
EPA ID Number

MS STATE PORT AUTHORITY TRUCK STOP (Continued)

U001298954

Date Removed: 04/18/1992  
Close Type: 04/18/1992  
Tank Material: Unknown  
2nd Containmnt: None  
Tank Lead Detection: N/A  
Overfill Protection: No  
Spill Prevention: No

Pipe:

Tank No: 1  
Tank Id: 1961  
Pipe Id: 1  
Pipe Status: Permanently Out of Use  
Type Of Closure: Closed  
Pipe Material Construction: Unknown  
Secondary Pipe Material: None  
Piping Type: N/A  
Pipe Leak Detection: Not Listed

Tank:

Tank No: 2  
Tank ID: 1962  
**Tank Status: Permanently Out of Use**  
Tank Capacity: 8000  
Date Installed: 01/01/1976  
Substance: Diesel  
Reported Release: Yes  
Close Type: Closed  
Date Removed: 04/18/1992  
Close Type: 04/18/1992  
Tank Material: Unknown  
2nd Containmnt: None  
Tank Lead Detection: N/A  
Overfill Protection: No  
Spill Prevention: No

Pipe:

Tank No: 2  
Tank Id: 1962  
Pipe Id: 2  
Pipe Status: Permanently Out of Use  
Type Of Closure: Closed  
Pipe Material Construction: Unknown  
Secondary Pipe Material: None  
Piping Type: N/A  
Pipe Leak Detection: Not Listed

Tank:

Tank No: 3  
Tank ID: 1963  
**Tank Status: Permanently Out of Use**  
Tank Capacity: 10000  
Date Installed: 01/01/1976

Map ID  
Direction  
Distance  
Elevation

MAP FINDINGS

Site

Database(s)

EDR ID Number  
EPA ID Number

MS STATE PORT AUTHORITY TRUCK STOP (Continued)

U001298954

Substance: Diesel  
Reported Release: Yes  
Close Type: Closed  
Date Removed: 04/18/1992  
Close Type: 04/18/1992  
Tank Material: Unknown  
2nd Containmnt: None  
Tank Lead Detection: N/A  
Overfill Protection: No  
Spill Prevention: No

Pipe:

Tank No: 3  
Tank Id: 1963  
Pipe Id: 3  
Pipe Status: Permanently Out of Use  
Type Of Closure: Closed  
Pipe Material Construction: Unknown  
Secondary Pipe Material: None  
Piping Type: N/A  
Pipe Leak Detection: Not Listed

Tank:

Tank No: 4  
Tank ID: 1964  
**Tank Status: Permanently Out of Use**  
Tank Capacity: 10000  
Date Installed: 01/01/1976  
Substance: Diesel  
Reported Release: Yes  
Close Type: Closed  
Date Removed: 04/18/1992  
Close Type: 04/18/1992  
Tank Material: Unknown  
2nd Containmnt: None  
Tank Lead Detection: N/A  
Overfill Protection: No  
Spill Prevention: No

Pipe:

Tank No: 4  
Tank Id: 1964  
Pipe Id: 4  
Pipe Status: Permanently Out of Use  
Type Of Closure: Closed  
Pipe Material Construction: Unknown  
Secondary Pipe Material: None  
Piping Type: N/A  
Pipe Leak Detection: Not Listed

Tank:

Tank No: 5  
Tank ID: 1965

Map ID  
Direction  
Distance  
Elevation

MAP FINDINGS

Site

Database(s)

EDR ID Number  
EPA ID Number

MS STATE PORT AUTHORITY TRUCK STOP (Continued)

U001298954

**Tank Status:** Permanently Out of Use  
Tank Capacity: 10000  
Date Installed: 01/01/1976  
Substance: Gasoline  
Reported Release: Yes  
Close Type: Closed  
Date Removed: 04/18/1992  
Close Type: 04/18/1992  
Tank Material: Asphalt Coated or Bare Steel  
2nd Containmnt: None  
Tank Lead Detection: N/A  
Overfill Protection: No  
Spill Prevention: No

Pipe:  
Tank No: 5  
Tank Id: 1965  
Pipe Id: 5  
Pipe Status: Permanently Out of Use  
Type Of Closure: Closed  
Pipe Material Construction: Unknown  
Secondary Pipe Material: None  
Piping Type: N/A  
Pipe Leak Detection: Not Listed

Tank:  
Tank No: 6  
Tank ID: 1966  
**Tank Status:** Permanently Out of Use  
Tank Capacity: 10000  
Date Installed: 01/01/1976  
Substance: Gasoline  
Reported Release: Yes  
Close Type: Closed  
Date Removed: 04/18/1992  
Close Type: 04/18/1992  
Tank Material: Asphalt Coated or Bare Steel  
2nd Containmnt: None  
Tank Lead Detection: N/A  
Overfill Protection: No  
Spill Prevention: No

Pipe:  
Tank No: 6  
Tank Id: 1966  
Pipe Id: 6  
Pipe Status: Permanently Out of Use  
Type Of Closure: Closed  
Pipe Material Construction: Unknown  
Secondary Pipe Material: None  
Piping Type: N/A  
Pipe Leak Detection: Not Listed



Map ID  
Direction  
Distance  
Elevation

MAP FINDINGS

Site

Database(s)

EDR ID Number  
EPA ID Number

MS STATE PORT AUTHORITY TRUCK STOP (Continued)

U001298954

Tank:

Tank No: 7  
Tank ID: 1967  
**Tank Status: Permanently Out of Use**  
Tank Capacity: 10000  
Date Installed: 01/01/1976  
Substance: Gasoline  
Reported Release: Yes  
Close Type: Closed  
Date Removed: 04/18/1992  
Close Type: 04/18/1992  
Tank Material: Asphalt Coated or Bare Steel  
2nd Containmnt: None  
Tank Lead Detection: N/A  
Overfill Protection: No  
Spill Prevention: No

Pipe:

Tank No: 7  
Tank Id: 1967  
Pipe Id: 7  
Pipe Status: Permanently Out of Use  
Type Of Closure: Closed  
Pipe Material Construction: Unknown  
Secondary Pipe Material: None  
Piping Type: N/A  
Pipe Leak Detection: Not Listed

B14  
WNW  
< 1/8  
0.122 mi.  
645 ft.

CHIQUITA BRANDS INC  
HIGHWAY 90 & 30TH AVENUE  
GULFPORT, MS 39502

Site 3 of 7 in cluster B

RCRA-CESQG 1000475167  
UST MSD094920725  
ICIS  
FINDS

Relative:  
Higher

RCRA-CESQG:

Date form received by agency: 07/17/1997  
Facility name: CHIQUITA BRANDS, INC.  
Facility address: HIGHWAY 90 & 30TH AVENUE  
GULFPORT, MS 39502  
EPA ID: MSD094920725  
Mailing address: P.O. BOX 1017  
GULFPORT, MS 39502  
Contact: RICHARD MOORE  
Contact address: P.O. BOX 1017  
GULFPORT, MS 39502  
Contact country: US  
Contact telephone: (601) 864-5046  
Contact email: Not reported  
EPA Region: 04  
Land type: Private  
Classification: Conditionally Exempt Small Quantity Generator  
Description: Handler: generates 100 kg or less of hazardous waste per calendar month, and accumulates 1000 kg or less of hazardous waste at any time; or generates 1 kg or less of acutely hazardous waste per calendar month, and accumulates at any time: 1 kg or less of acutely hazardous waste; or 100 kg or less of any residue or contaminated soil, waste or other debris resulting from the cleanup of a spill, into or on any

Actual:  
18 ft.

Map ID  
Direction  
Distance  
Elevation

MAP FINDINGS

Site

Database(s)

EDR ID Number  
EPA ID Number

**CHIQUITA BRANDS INC (Continued)**

**1000475167**

land or water, of acutely hazardous waste; or generates 100 kg or less of any residue or contaminated soil, waste or other debris resulting from the cleanup of a spill, into or on any land or water, of acutely hazardous waste during any calendar month, and accumulates at any time: 1 kg or less of acutely hazardous waste; or 100 kg or less of any residue or contaminated soil, waste or other debris resulting from the cleanup of a spill, into or on any land or water, of acutely hazardous waste

Owner/Operator Summary:

Owner/operator name: CHIQUITA BRANDS, INC.  
Owner/operator address: 250 EAST 5TH STREET  
CINCINNATI, OH 45202  
Owner/operator country: Not reported  
Owner/operator telephone: (513) 784-8000  
Legal status: Private  
Owner/Operator Type: Owner  
Owner/Op start date: Not reported  
Owner/Op end date: Not reported

Handler Activities Summary:

U.S. importer of hazardous waste: No  
Mixed waste (haz. and radioactive): No  
Recycler of hazardous waste: No  
Transporter of hazardous waste: No  
Treater, storer or disposer of HW: No  
Underground injection activity: No  
On-site burner exemption: No  
Furnace exemption: No  
Used oil fuel burner: No  
Used oil processor: No  
User oil refiner: No  
Used oil fuel marketer to burner: No  
Used oil Specification marketer: No  
Used oil transfer facility: No  
Used oil transporter: No

. Waste code: D001  
. Waste name: IGNITABLE WASTE

Facility Has Received Notices of Violations:

Regulation violated: SR - 262.S1  
Area of violation: Generators - General  
Date violation determined: 02/16/1994  
Date achieved compliance: 02/24/1994  
Violation lead agency: State  
Enforcement action: WRITTEN INFORMAL  
Enforcement action date: 02/16/1994  
Enf. disposition status: Not reported  
Enf. disp. status date: Not reported  
Enforcement lead agency: State  
Proposed penalty amount: Not reported  
Final penalty amount: Not reported  
Paid penalty amount: Not reported

Map ID  
Direction  
Distance  
Elevation

MAP FINDINGS

Site

Database(s)

EDR ID Number  
EPA ID Number

**CHIQUITA BRANDS INC (Continued)**

**1000475167**

Evaluation Action Summary:

Evaluation date: 02/16/1994  
Evaluation: FOCUSED COMPLIANCE INSPECTION  
Area of violation: Generators - General  
Date achieved compliance: 02/24/1994  
Evaluation lead agency: State

UST:

Facility ID: 517  
Facility Status: Inactive  
Latitude: 30 21' 75.0000"  
Longitude: 89 5' 86.0000"  
Permanently Out of Use Tanks: 3  
Active Tanks: 0  
AIID: 30356  
Owner Name: Chiquita Brands Inc  
Owner Address: PO Box 1017  
Owner Tele: (228)864-5046

Tank:

Tank No: 1  
Tank ID: 1433  
**Tank Status: Permanently Out of Use**  
Tank Capacity: 500  
Date Installed: 01/01/1984  
Substance: Gasoline  
Reported Release: Not reported  
Close Type: Closed  
Date Removed: 06/05/1993  
Close Type: 06/05/1993  
Tank Material: Asphalt Coated or Bare Steel  
2nd Containmnt: None  
Tank Lead Detection: N/A  
Overfill Protection: No  
Spill Prevention: No

Pipe:

Tank No: 1  
Tank Id: 1433  
Pipe Id: 1  
Pipe Status: Permanently Out of Use  
Type Of Closure: Closed  
Pipe Material Construction: Bare/Galvanized Steel  
Secondary Pipe Material: None  
Piping Type: N/A  
Pipe Leak Detection: Not Listed

Tank:

Tank No: 2  
Tank ID: 1434  
**Tank Status: Permanently Out of Use**  
Tank Capacity: 1000  
Date Installed: 01/01/1984  
Substance: Used Oil  
Reported Release: Not reported

Map ID  
Direction  
Distance  
Elevation

MAP FINDINGS

Site

Database(s)

EDR ID Number  
EPA ID Number

**CHIQUITA BRANDS INC (Continued)**

1000475167

Close Type: Closed  
Date Removed: 06/05/1993  
Close Type: 06/05/1993  
Tank Material: Asphalt Coated or Bare Steel  
2nd Containmnt: None  
Tank Lead Detection: N/A  
Overfill Protection: No  
Spill Prevention: No

**Tank:**

Tank No: 3  
Tank ID: 1435  
**Tank Status: Permanently Out of Use**  
Tank Capacity: 2000  
Date Installed: 01/01/1984  
Substance: Gasoline  
Reported Release: Not reported  
Close Type: Closed  
Date Removed: 03/08/1992  
Close Type: 03/08/1992  
Tank Material: Asphalt Coated or Bare Steel  
2nd Containmnt: None  
Tank Lead Detection: N/A  
Overfill Protection: No  
Spill Prevention: No

**Pipe:**

Tank No: 3  
Tank Id: 1435  
Pipe Id: 3  
Pipe Status: Permanently Out of Use  
Type Of Closure: Closed  
Pipe Material Construction: Bare/Galvanized Steel  
Secondary Pipe Material: None  
Piping Type: N/A  
Pipe Leak Detection: Not Listed

**ICIS:**

Enforcement Action ID: 04-2010-3007  
FRS ID: 110007646976  
Program ID: FRS 110007646976  
Action Name: ROBBINS ASSOCIATION/IRRIGATION-MART, INC.  
Full Address: HIGHWAY 90 & 30TH AVENUE GULFPORT MS 39502  
State: Mississippi  
Facility Name: CHIQUITA BRANDS INC  
Facility Address: HIGHWAY 90 & 30TH AVENUE  
GULFPORT, MS 39502  
Enforcement Action Type: FIFRA 14A Action For Penalty  
Facility County: HARRISON  
EPA Region #: 4

Enforcement Action ID: 04-2010-3007  
FRS ID: 110007646976  
Program ID: RCRAINFO MSD094920725  
Action Name: ROBBINS ASSOCIATION/IRRIGATION-MART, INC.

Map ID  
Direction  
Distance  
Elevation

MAP FINDINGS

Site

Database(s)

EDR ID Number  
EPA ID Number

**CHIQUITA BRANDS INC (Continued)**

**1000475167**

Full Address: HIGHWAY 90 & 30TH AVENUE GULFPORT MS 39502  
State: Mississippi  
Facility Name: CHIQUITA BRANDS INC  
Facility Address: HIGHWAY 90 & 30TH AVENUE  
GULFPORT, MS 39502  
Enforcement Action Type: FIFRA 14A Action For Penalty  
Facility County: HARRISON  
EPA Region #: 4

Enforcement Action ID: 04-2010-3007  
FRS ID: 110007646976  
Program ID: MS-ENSITE 4849  
Action Name: ROBBINS ASSOCIATION/IRRIGATION-MART, INC.  
Full Address: HIGHWAY 90 & 30TH AVENUE GULFPORT MS 39502  
State: Mississippi  
Facility Name: CHIQUITA BRANDS INC  
Facility Address: HIGHWAY 90 & 30TH AVENUE  
GULFPORT, MS 39502  
Enforcement Action Type: FIFRA 14A Action For Penalty  
Facility County: HARRISON  
EPA Region #: 4

Enforcement Action ID: 04-2010-3007  
FRS ID: 110007646976  
Program ID: MS-ENSITE 30356  
Action Name: ROBBINS ASSOCIATION/IRRIGATION-MART, INC.  
Full Address: HIGHWAY 90 & 30TH AVENUE GULFPORT MS 39502  
State: Mississippi  
Facility Name: CHIQUITA BRANDS INC  
Facility Address: HIGHWAY 90 & 30TH AVENUE  
GULFPORT, MS 39502  
Enforcement Action Type: FIFRA 14A Action For Penalty  
Facility County: HARRISON  
EPA Region #: 4

Program ID: FRS 110007646976  
Facility Name: CHIQUITA BRANDS INC  
Address: HIGHWAY 90 & 30TH AVENUE  
Tribal Indicator: N  
Fed Facility: No  
NAIC Code: Not reported  
SIC Code: Not reported

Program ID: MS-ENSITE 30356  
Facility Name: CHIQUITA BRANDS INC  
Address: HIGHWAY 90 & 30TH AVENUE  
Tribal Indicator: N  
Fed Facility: No  
NAIC Code: Not reported  
SIC Code: Not reported

Program ID: MS-ENSITE 4849  
Facility Name: CHIQUITA BRANDS INC  
Address: HIGHWAY 90 & 30TH AVENUE  
Tribal Indicator: N  
Fed Facility: No

Map ID  
 Direction  
 Distance  
 Elevation

MAP FINDINGS

Site

Database(s)

EDR ID Number  
 EPA ID Number

**CHIQUITA BRANDS INC (Continued)**

**1000475167**

NAIC Code: Not reported  
 SIC Code: Not reported

Program ID: RCRAINFO MSD094920725  
 Facility Name: CHIQUITA BRANDS INC  
 Address: HIGHWAY 90 & 30TH AVENUE  
 Tribal Indicator: N  
 Fed Facility: No  
 NAIC Code: Not reported  
 SIC Code: Not reported

**FINDS:**

Registry ID: 110007646976

**Environmental Interest/Information System**

MS-ENSITE (Mississippi - Tools For Environmental Management And Protection Organizations). Mississippi Department of Environmental Quality (MDEQ) Office of Pollution Control's (OPC) maintains enSite. It is the electronic Environmental Site Information System that regulates compliance assurance, permitting, activity tracking, and maintenance of a single agency interest-link to definition master file.

RCRAInfo is a national information system that supports the Resource Conservation and Recovery Act (RCRA) program through the tracking of events and activities related to facilities that generate, transport, and treat, store, or dispose of hazardous waste. RCRAInfo allows RCRA program staff to track the notification, permit, compliance, and corrective action activities required under RCRA.

ICIS (Integrated Compliance Information System) is the Integrated Compliance Information System and provides a database that, when complete, will contain integrated Enforcement and Compliance information across most of EPA's programs. The vision for ICIS is to replace EPA's independent databases that contain Enforcement data with a single repository for that information. Currently, ICIS contains all Federal Administrative and Judicial enforcement actions. This information is maintained in ICIS by EPA in the Regional offices and it Headquarters. A future release of ICIS will replace the Permit Compliance System (PCS) which supports the NPDES and will integrate that information with Federal actions already in the system. ICIS also has the capability to track other activities occurring in the Region that support Compliance and Enforcement programs. These include; Incident Tracking, Compliance Assistance, and Compliance Monitoring.

**C15**  
**ENE**  
 1/8-1/4  
 0.134 mi.  
 709 ft.

**FORMER BARON #75**  
**2501 WEST BEACH BOULEVARD**  
**GULFPORT, MS 39505**  
 Site 7 of 9 in cluster C

**LUST** **U001298068**  
**UST** **N/A**

**Relative:**  
**Higher**  
**Actual:**  
 12 ft.

Facility Id: 752  
 Facility Satus: Inactive  
 Lust Status: Closed

Map ID  
Direction  
Distance  
Elevation

MAP FINDINGS

Site

Database(s)

EDR ID Number  
EPA ID Number

**FORMER BARON #75 (Continued)**

**U001298068**

AIID: 29003  
Event #: 1  
Project Manager: Dan Harper  
Date Of Report: 02/25/2010  
Trust Fund Status: STFS  
Confirmed On: 03/03/2010  
NFA Date: 10/20/2011

UST:

Facility ID: 752  
Facility Status: Inactive  
Latitude: 30 21' 36.0000"  
Longitude: 89 6' 30.0000"  
Permanently Out of Use Tanks: 3  
Active Tanks: 0  
AIID: 29003  
Owner Name: Barber Southern LLC  
Owner Address: 116 Brighton Close  
Owner Tele: (615)298-3990

Tank:

Tank No: 1  
Tank ID: 1975  
**Tank Status: Permanently Out of Use**  
Tank Capacity: 8000  
Date Installed: 01/01/1970  
Substance: Gasoline  
Reported Release: Yes  
Close Type: Closed  
Date Removed: 06/19/1990  
Close Type: 06/19/1990  
Tank Material: Asphalt Coated or Bare Steel  
2nd Containmnt: None  
Tank Lead Detection: N/A  
Overfill Protection: No  
Spill Prevention: No

Pipe:

Tank No: 1  
Tank Id: 1975  
Pipe Id: 1  
Pipe Status: Permanently Out of Use  
Type Of Closure: Closed  
Pipe Material Construction: Bare/Galvanized Steel  
Secondary Pipe Material: None  
Piping Type: N/A  
Pipe Leak Detection: Not Listed

Tank:

Tank No: 2  
Tank ID: 1976  
**Tank Status: Permanently Out of Use**  
Tank Capacity: 6000  
Date Installed: 01/01/1970



Map ID  
Direction  
Distance  
Elevation

MAP FINDINGS

Site

Database(s)

EDR ID Number  
EPA ID Number

**FORMER BARON #75 (Continued)**

**U001298068**

Substance: Gasoline  
Reported Release: Yes  
Close Type: Closed  
Date Removed: 06/19/1990  
Close Type: 06/19/1990  
Tank Material: Asphalt Coated or Bare Steel  
2nd Containmnt: None  
Tank Lead Detection: N/A  
Overfill Protection: No  
Spill Prevention: No

Pipe:

Tank No: 2  
Tank Id: 1976  
Pipe Id: 2  
Pipe Status: Permanently Out of Use  
Type Of Closure: Closed  
Pipe Material Construction: Bare/Galvanized Steel  
Secondary Pipe Material: None  
Piping Type: N/A  
Pipe Leak Detection: Not Listed

Tank:

Tank No: 3  
Tank ID: 1977  
**Tank Status: Permanently Out of Use**  
Tank Capacity: 6000  
Date Installed: 01/01/1970  
Substance: Gasoline  
Reported Release: Yes  
Close Type: Closed  
Date Removed: 06/19/1990  
Close Type: 06/19/1990  
Tank Material: Asphalt Coated or Bare Steel  
2nd Containmnt: None  
Tank Lead Detection: N/A  
Overfill Protection: No  
Spill Prevention: No

Pipe:

Tank No: 3  
Tank Id: 1977  
Pipe Id: 3  
Pipe Status: Permanently Out of Use  
Type Of Closure: Closed  
Pipe Material Construction: Bare/Galvanized Steel  
Secondary Pipe Material: None  
Piping Type: N/A  
Pipe Leak Detection: Not Listed

MAP FINDINGS

Map ID			EDR ID Number
Direction			EPA ID Number
Distance			
Elevation	Site	Database(s)	

<b>C16</b> <b>ENE</b> <b>1/8-1/4</b> <b>0.134 mi.</b> <b>709 ft.</b>	<b>BARON #75</b> <b>2501 WEST BEACH BOULEVARD</b> <b>GULFPORT, MS</b>  <b>Site 8 of 9 in cluster C</b>	<b>RGA LUST</b>	<b>S116267901</b> <b>N/A</b>
<b>Relative:</b> <b>Higher</b>	RGA LUST: 2010 BARON #75 2501 WEST BEACH BOULEVARD		
<b>Actual:</b> <b>12 ft.</b>			

<b>C17</b> <b>ENE</b> <b>1/8-1/4</b> <b>0.134 mi.</b> <b>709 ft.</b>	<b>FORMER BARON #75</b> <b>2501 WEST BEACH BOULEVARD</b> <b>GULFPORT, MS</b>  <b>Site 9 of 9 in cluster C</b>	<b>RGA LUST</b>	<b>S116270092</b> <b>N/A</b>
<b>Relative:</b> <b>Higher</b>	RGA LUST: 2012 FORMER BARON #75 2501 WEST BEACH BOULEVARD 2011 FORMER BARON #75 2501 WEST BEACH BOULEVARD		
<b>Actual:</b> <b>12 ft.</b>			

<b>B18</b> <b>West</b> <b>1/8-1/4</b> <b>0.136 mi.</b> <b>718 ft.</b>	<b>MS POWER COMPANY GENERAL OFFICE</b> <b>2992 WEST BEACH BOULEVARD</b> <b>GULFPORT, MS 39501</b>  <b>Site 4 of 7 in cluster B</b>	<b>UST</b>	<b>U003774004</b> <b>N/A</b>																				
<b>Relative:</b> <b>Higher</b>	UST: <table border="0" style="margin-left: 20px;"> <tr> <td>Facility ID:</td> <td>10580</td> </tr> <tr> <td>Facility Status:</td> <td>Inactive</td> </tr> <tr> <td>Latitude:</td> <td>30 21' 54.7100"</td> </tr> <tr> <td>Longitude:</td> <td>89 5' 48.8400"</td> </tr> <tr> <td>Permanently Out of Use Tanks:</td> <td>2</td> </tr> <tr> <td>Active Tanks:</td> <td>0</td> </tr> <tr> <td>AIID:</td> <td>26144</td> </tr> <tr> <td>Owner Name:</td> <td>Not reported</td> </tr> <tr> <td>Owner Address:</td> <td>Not reported</td> </tr> <tr> <td>Owner Tele:</td> <td>Not reported</td> </tr> </table>			Facility ID:	10580	Facility Status:	Inactive	Latitude:	30 21' 54.7100"	Longitude:	89 5' 48.8400"	Permanently Out of Use Tanks:	2	Active Tanks:	0	AIID:	26144	Owner Name:	Not reported	Owner Address:	Not reported	Owner Tele:	Not reported
Facility ID:	10580																						
Facility Status:	Inactive																						
Latitude:	30 21' 54.7100"																						
Longitude:	89 5' 48.8400"																						
Permanently Out of Use Tanks:	2																						
Active Tanks:	0																						
AIID:	26144																						
Owner Name:	Not reported																						
Owner Address:	Not reported																						
Owner Tele:	Not reported																						

Tank:

Tank No:	1
Tank ID:	26884
<b>Tank Status:</b>	<b>Permanently Out of Use</b>
Tank Capacity:	260
Date Installed:	01/01/1986
Substance:	Diesel
Reported Release:	Not reported
Close Type:	Closed
Date Removed:	10/24/1998
Close Type:	11/24/1998
Tank Material:	Composite (Steel w/ FRP)
2nd Containmnt:	None
Tank Lead Detection:	Deferred
Overfill Protection:	No
Spill Prevention:	No

Pipe:

Tank No:	1
Tank Id:	26884

Map ID  
Direction  
Distance  
Elevation

MAP FINDINGS

Site

Database(s)

EDR ID Number  
EPA ID Number

**MS POWER COMPANY GENERAL OFFICE (Continued)**

**U003774004**

Pipe Id: 1  
Pipe Status: Permanently Out of Use  
Type Of Closure: Closed  
Pipe Material Construction: Copper  
Secondary Pipe Material: None  
Piping Type: N/A  
Pipe Leak Detection: Deferred

**Tank:**

Tank No: 2  
Tank ID: 26885  
**Tank Status: Permanently Out of Use**  
Tank Capacity: 400  
Date Installed: 10/24/1998  
Substance: Diesel  
Reported Release: Not reported  
Close Type: Closed  
Date Removed: 05/03/2006  
Close Type: 05/03/2006  
Tank Material: Composite (Steel w/ FRP)  
2nd Containmnt: Double-Walled  
Tank Lead Detection: Deferred  
Overfill Protection: Yes  
Spill Prevention: Yes

**Pipe:**

Tank No: 2  
Tank Id: 26885  
Pipe Id: 2  
Pipe Status: Permanently Out of Use  
Type Of Closure: Closed  
Pipe Material Construction: Flexible Plastic  
Secondary Pipe Material: Double-Walled  
Piping Type: Safe Suction  
Pipe Leak Detection: N/A

**B19**  
**West**  
**1/8-1/4**  
**0.136 mi.**  
**718 ft.**

**MS POWER COMPANY GENERAL OFFICE**  
**2992 WEST BEACH BOULEVARD**  
**GULFPORT, MS 39501**  
**Site 5 of 7 in cluster B**

**FINDS 1016025347**  
**N/A**

**Relative:**  
**Higher**

**FINDS:**

Registry ID: 110044686514

**Actual:**  
**13 ft.**

Environmental Interest/Information System  
MS-ENSITE (Mississippi - Tools For Environmental Management And Protection Organizations). Mississippi Department of Environmental Quality (MDEQ) Office of Pollution Control's (OPC) maintains enSite. It is the electronic Environmental Site Information System that that regulates compliance assurance, permitting, activity tracking, and maintenance of a single agency interest-link to definition master file.

Map ID  
Direction  
Distance  
Elevation

MAP FINDINGS

Site

Database(s)

EDR ID Number  
EPA ID Number

**B20**  
**West**  
**1/8-1/4**  
**0.142 mi.**  
**750 ft.**

**SUPERIOR CHRYSLER-PLYMOUTH**  
**3002 WEST BEACH BOULEVARD**  
**GULFPORT, MS 39501**

**RCRA NonGen / NLR**    **1000475621**  
**MSD982104473**

**Site 6 of 7 in cluster B**

**Relative:**  
**Higher**

RCRA NonGen / NLR:

**Actual:**  
**14 ft.**

Date form received by agency: 04/13/1987  
Facility name: SUPERIOR CHRYSLER-PLYMOUTH  
Facility address: 3002 WEST BEACH BOULEVARD  
GULFPORT, MS 39501  
EPA ID: MSD982104473  
Mailing address: WEST BEACH BOULEVARD  
GULFPORT, MS 39501  
Contact: MIKE CAMINITA  
Contact address: 3002 WEST BEACH BOULEVARD  
GULFPORT, MS 39501  
Contact country: US  
Contact telephone: (601) 864-7474  
Contact email: Not reported  
EPA Region: 04  
Classification: Non-Generator  
Description: Handler: Non-Generators do not presently generate hazardous waste

Owner/Operator Summary:

Owner/operator name: JACK HIGGINS  
Owner/operator address: Not reported  
Not reported  
Owner/operator country: Not reported  
Owner/operator telephone: Not reported  
Legal status: Private  
Owner/Operator Type: Owner  
Owner/Op start date: Not reported  
Owner/Op end date: Not reported

Handler Activities Summary:

U.S. importer of hazardous waste: No  
Mixed waste (haz. and radioactive): No  
Recycler of hazardous waste: No  
Transporter of hazardous waste: No  
Treater, storer or disposer of HW: No  
Underground injection activity: No  
On-site burner exemption: No  
Furnace exemption: No  
Used oil fuel burner: No  
Used oil processor: No  
Used oil refiner: No  
Used oil fuel marketer to burner: No  
Used oil Specification marketer: No  
Used oil transfer facility: No  
Used oil transporter: No

. Waste code: D000  
. Waste name: Not Defined  
  
. Waste code: D001  
. Waste name: IGNITABLE WASTE

Map ID  
Direction  
Distance  
Elevation

MAP FINDINGS

Site

Database(s)

EDR ID Number  
EPA ID Number

**SUPERIOR CHRYSLER-PLYMOUTH (Continued)**

**1000475621**

- . Waste code: F002
- . Waste name: THE FOLLOWING SPENT HALOGENATED SOLVENTS: TETRACHLOROETHYLENE, METHYLENE CHLORIDE, TRICHLOROETHYLENE, 1,1,1-TRICHLOROETHANE, CHLOROBENZENE, 1,1,2-TRICHLORO-1,2,2-TRIFLUOROETHANE, ORTHO-DICHLOROBENZENE, TRICHLOROFLUOROMETHANE, AND 1,1,2, TRICHLOROETHANE; ALL SPENT SOLVENT MIXTURES/BLENDS CONTAINING, BEFORE USE, A TOTAL OF TEN PERCENT OR MORE (BY VOLUME) OF ONE OR MORE OF THE ABOVE HALOGENATED SOLVENTS OR THOSE SOLVENTS LISTED IN F001, F004, AND F005; AND STILL BOTTOMS FROM THE RECOVERY OF THESE SPENT SOLVENTS AND SPENT SOLVENT MIXTURES.
  
- . Waste code: F003
- . Waste name: THE FOLLOWING SPENT NONHALOGENATED SOLVENTS: XYLENE, ACETONE, ETHYL ACETATE, ETHYL BENZENE, ETHYL ETHER, METHYL ISOBUTYL KETONE, N-BUTYL ALCOHOL, CYCLOHEXANONE, AND METHANOL; ALL SPENT SOLVENT MIXTURES/BLENDS CONTAINING, BEFORE USE, ONLY THE ABOVE SPENT NONHALOGENATED SOLVENTS; AND ALL SPENT SOLVENT MIXTURES/BLENDS CONTAINING, BEFORE USE, ONE OR MORE OF THE ABOVE NONHALOGENATED SOLVENTS, AND A TOTAL OF TEN PERCENT OR MORE (BY VOLUME) OF ONE OR MORE OF THOSE SOLVENTS LISTED IN F001, F002, F004, AND F005; AND STILL BOTTOMS FROM THE RECOVERY OF THESE SPENT SOLVENTS AND SPENT SOLVENT MIXTURES.
  
- . Waste code: F004
- . Waste name: THE FOLLOWING SPENT NONHALOGENATED SOLVENTS: CRESOLS, CRESYLIC ACID, AND NITROBENZENE; AND THE STILL BOTTOMS FROM THE RECOVERY OF THESE SOLVENTS; ALL SPENT SOLVENT MIXTURES/BLENDS CONTAINING, BEFORE USE, A TOTAL OF TEN PERCENT OR MORE (BY VOLUME) OF ONE OR MORE OF THE ABOVE NONHALOGENATED SOLVENTS OR THOSE SOLVENTS LISTED IN F001, F002, AND F005; AND STILL BOTTOMS FROM THE RECOVERY OF THESE SPENT SOLVENTS AND SPENT SOLVENT MIXTURES.
  
- . Waste code: F005
- . Waste name: THE FOLLOWING SPENT NONHALOGENATED SOLVENTS: TOLUENE, METHYL ETHYL KETONE, CARBON DISULFIDE, ISOBUTANOL, PYRIDINE, BENZENE, 2-ETHOXYETHANOL, AND 2-NITROPROPANE; ALL SPENT SOLVENT MIXTURES/BLENDS CONTAINING, BEFORE USE, A TOTAL OF TEN PERCENT OR MORE (BY VOLUME) OF ONE OR MORE OF THE ABOVE NONHALOGENATED SOLVENTS OR THOSE SOLVENTS LISTED IN F001, F002, OR F004; AND STILL BOTTOMS FROM THE RECOVERY OF THESE SPENT SOLVENTS AND SPENT SOLVENT MIXTURES.

Violation Status: No violations found

**B21**  
**West**  
**1/8-1/4**  
**0.142 mi.**  
**750 ft.**

**SUPERIOR CHRYSLER PLYMOUTH**  
**3002 WEST BEACH BOULEVARD**  
**GULFPORT, MS 39501**

**FINDS 1016608912**  
**N/A**

**Site 7 of 7 in cluster B**

**Relative:**  
**Higher**

FINDS:

Registry ID: 110003997630

**Actual:**  
**14 ft.**

Environmental Interest/Information System

RCRAInfo is a national information system that supports the Resource Conservation and Recovery Act (RCRA) program through the tracking of events and activities related to facilities that generate, transport, and treat, store, or dispose of hazardous waste. RCRAInfo allows RCRA program staff to track the notification, permit, compliance, and

Map ID  
 Direction  
 Distance  
 Elevation

MAP FINDINGS

Site

Database(s)

EDR ID Number  
 EPA ID Number

**SUPERIOR CHRYSLER PLYMOUTH (Continued)**

**1016608912**

corrective action activities required under RCRA.

MS-ENSITE (Mississippi - Tools For Environmental Management And Protection Organizations). Mississippi Department of Environmental Quality (MDEQ) Office of Pollution Control's (OPC) maintains enSite. It is the electronic Environmental Site Information System that that regulates compliance assurance, permitting, activity tracking, and maintenance of a single agency interest-link to definition master file.

<b>D22</b> <b>NW</b> <b>1/8-1/4</b> <b>0.145 mi.</b> <b>765 ft.</b>	<b>FAST TRAC #23</b> <b>1119 30TH AVENUE</b> <b>GULFPORT, MS</b>  <b>Site 1 of 13 in cluster D</b>	<b>RGA LUST</b>	<b>S116269949</b> <b>N/A</b>
---	--	-----------------	---------------------------------

Relative:  
 Higher

RGA LUST:

2012	FAST TRAC #23	1119 30TH AVENUE
2011	FAST TRAC #23	1119 30TH AVENUE
2010	FAST TRAC #23	1119 30TH AVENUE
2009	FAST TRAC #23	1119 30TH AVENUE
2008	FAST TRAC #23	1119 30TH AVENUE
2007	FAST TRAC #23	1119 30TH AVENUE
2006	FAST TRAC #23	1119 30TH AVENUE
2005	FAST TRAC #23	1119 30TH AVENUE
2004	FAST TRAC #23	1119 30TH AVENUE
2003	FAST TRAC #23	1119 30TH AVENUE

Actual:  
 20 ft.

<b>D23</b> <b>NW</b> <b>1/8-1/4</b> <b>0.145 mi.</b> <b>765 ft.</b>	<b>30TH AVENUE CHEVRON FOOD MART</b> <b>1119 30TH AVENUE</b> <b>GULFPORT, MS</b>  <b>Site 2 of 13 in cluster D</b>	<b>RGA LUST</b>	<b>S116267330</b> <b>N/A</b>
---	--	-----------------	---------------------------------

Relative:  
 Higher

RGA LUST:

1996	30TH AVENUE CHEVRON FOOD MART	1119 30TH AVENUE
------	-------------------------------	------------------

Actual:  
 20 ft.

<b>D24</b> <b>NW</b> <b>1/8-1/4</b> <b>0.145 mi.</b> <b>765 ft.</b>	<b>30TH AVE CHEVRON FOOD MART</b> <b>1119 30TH AVENUE</b> <b>GULFPORT, MS</b>  <b>Site 3 of 13 in cluster D</b>	<b>RGA LUST</b>	<b>S116267329</b> <b>N/A</b>
---	---	-----------------	---------------------------------

Relative:  
 Higher

RGA LUST:

1999	30TH AVE CHEVRON FOOD MART	1119 30TH AVENUE
1998	30TH AVE CHEVRON FOOD MART	1119 30TH AVENUE
1997	30TH AVE CHEVRON FOOD MART	1119 30TH AVENUE

Actual:  
 20 ft.

Map ID  
Direction  
Distance  
Elevation

MAP FINDINGS

Site

Database(s)

EDR ID Number  
EPA ID Number

D25  
NW  
1/8-1/4  
0.145 mi.  
765 ft.

**SWIFTY SERVE #527**  
1119 30TH AVENUE  
GULFPOR, MS  
**Site 4 of 13 in cluster D**

**RGA LUST** S116274100  
N/A

**Relative:**  
**Higher**  
  
**Actual:**  
20 ft.

RGA LUST:  
2002 SWIFTY SERVE #527 1119 30TH AVENUE  
2001 SWIFTY SERVE #527 1119 30TH AVENUE  
2000 SWIFTY SERVE #527 1119 30TH AVENUE

D26  
NW  
1/8-1/4  
0.145 mi.  
765 ft.

**FAST MART #23**  
1119 30TH AVENUE  
GULFPOR, MS 39501  
**Site 5 of 13 in cluster D**

**LUST** U001297116  
**UST** N/A

**Relative:**  
**Higher**  
  
**Actual:**  
20 ft.

Facility Id: 4251  
Facility Satus: Active  
Lust Status: Closed  
AIID: 26492  
Event #: 1  
Project Manager: Larry Flynt  
Date Of Report: 05/10/1990  
Trust Fund Status: STFS  
Confirmed On: 05/10/1990  
NFA Date: 12/04/1990  
  
Facility Id: 4251  
Facility Satus: Active  
Lust Status: Closed  
AIID: 26492  
Event #: 2  
Project Manager: Michael Usry  
Date Of Report: 10/17/2006  
Trust Fund Status: Katrina  
Confirmed On: Not reported  
NFA Date: 03/14/2007

UST:  
Facility ID: 4251  
Facility Status: Active  
Latitude: 30 21' 57.3000"  
Longitude: 89 5' 53.0000"  
Permanently Out of Use Tanks: 5  
Active Tanks: 3  
AIID: 26492  
Owner Name: Not reported  
Owner Address: Not reported  
Owner Tele: Not reported

Tank:  
Tank No: 1  
Tank ID: 10623  
**Tank Status: Permanently Out of Use**  
Tank Capacity: 5000  
Date Installed: 01/01/1970  
Substance: Gasoline  
Reported Release: Yes



Map ID  
Direction  
Distance  
Elevation

MAP FINDINGS

Site

Database(s)

EDR ID Number  
EPA ID Number

**FAST MART #23 (Continued)**

**U001297116**

Close Type: Closed  
Date Removed: 05/03/1990  
Close Type: 05/03/1990  
Tank Material: Asphalt Coated or Bare Steel  
2nd Containmnt: None  
Tank Lead Detection: N/A  
Overfill Protection: No  
Spill Prevention: No

Pipe:

Tank No: 1  
Tank Id: 10623  
Pipe Id: 1  
Pipe Status: Permanently Out of Use  
Type Of Closure: Closed  
Pipe Material Construction: Bare/Galvanized Steel  
Secondary Pipe Material: Cathodically Protected  
Piping Type: N/A  
Pipe Leak Detection: Not Listed

Tank:

Tank No: 2  
Tank ID: 10624  
**Tank Status: Permanently Out of Use**  
Tank Capacity: 10000  
Date Installed: 01/01/1970  
Substance: Gasoline  
Reported Release: Yes  
Close Type: Closed  
Date Removed: 05/03/1990  
Close Type: 05/03/1990  
Tank Material: Asphalt Coated or Bare Steel  
2nd Containmnt: None  
Tank Lead Detection: N/A  
Overfill Protection: No  
Spill Prevention: No

Pipe:

Tank No: 2  
Tank Id: 10624  
Pipe Id: 2  
Pipe Status: Permanently Out of Use  
Type Of Closure: Closed  
Pipe Material Construction: Bare/Galvanized Steel  
Secondary Pipe Material: Cathodically Protected  
Piping Type: N/A  
Pipe Leak Detection: Not Listed

Tank:

Tank No: 3  
Tank ID: 10625  
**Tank Status: Permanently Out of Use**  
Tank Capacity: 10000

Map ID  
Direction  
Distance  
Elevation

MAP FINDINGS

Site

Database(s)

EDR ID Number  
EPA ID Number

**FAST MART #23 (Continued)**

**U001297116**

Date Installed: 01/01/1970  
Substance: Gasoline  
Reported Release: Yes  
Close Type: Closed  
Date Removed: 05/03/1990  
Close Type: 05/03/1990  
Tank Material: Asphalt Coated or Bare Steel  
2nd Containmnt: None  
Tank Lead Detection: N/A  
Overfill Protection: No  
Spill Prevention: No

Pipe:

Tank No: 3  
Tank Id: 10625  
Pipe Id: 3  
Pipe Status: Permanently Out of Use  
Type Of Closure: Closed  
Pipe Material Construction: Bare/Galvanized Steel  
Secondary Pipe Material: Cathodically Protected  
Piping Type: N/A  
Pipe Leak Detection: Not Listed

Tank:

Tank No: 4  
Tank ID: 10626  
**Tank Status: Permanently Out of Use**  
Tank Capacity: 550  
Date Installed: 01/01/1970  
Substance: Used Oil  
Reported Release: Yes  
Close Type: Closed  
Date Removed: 05/03/1990  
Close Type: 05/03/1990  
Tank Material: Asphalt Coated or Bare Steel  
2nd Containmnt: None  
Tank Lead Detection: N/A  
Overfill Protection: No  
Spill Prevention: No

Tank:

Tank No: 5  
Tank ID: 10627  
**Tank Status: Permanently Out of Use**  
Tank Capacity: 2000  
Date Installed: 01/01/1970  
Substance: Diesel  
Reported Release: Yes  
Close Type: Closed  
Date Removed: 05/03/1990  
Close Type: 05/03/1990  
Tank Material: Asphalt Coated or Bare Steel  
2nd Containmnt: None  
Tank Lead Detection: N/A

Map ID  
Direction  
Distance  
Elevation

MAP FINDINGS

Site

Database(s)

EDR ID Number  
EPA ID Number

**FAST MART #23 (Continued)**

**U001297116**

Overfill Protection: No  
Spill Prevention: No

Pipe:  
Tank No: 5  
Tank Id: 10627  
Pipe Id: 5  
Pipe Status: Permanently Out of Use  
Type Of Closure: Closed  
Pipe Material Construction: Bare/Galvanized Steel  
Secondary Pipe Material: Cathodically Protected  
Piping Type: N/A  
Pipe Leak Detection: Not Listed

Tank:  
Tank No: 6  
Tank ID: 10628  
**Tank Status: Currently In Use**  
Tank Capacity: 10000  
Date Installed: 08/14/1990  
Substance: Gasoline  
Reported Release: Yes  
Close Type: Not reported  
Date Removed: Not reported  
Close Type: Not reported  
Tank Material: Epoxy Coated Steel  
2nd Containmnt: Cathodically Protected  
Tank Lead Detection: Groundwater/Vapor Monitoring  
Overfill Protection: Yes  
Spill Prevention: Yes

Pipe:  
Tank No: 6  
Tank Id: 10628  
Pipe Id: 6  
Pipe Status: Currently In Use  
Type Of Closure: Not reported  
Pipe Material Construction: Fiberglass Reinforced Plastic  
Secondary Pipe Material: Double-Walled  
Piping Type: Pressurized  
Pipe Leak Detection: Groundwater/Vapor Monitoring

Tank:  
Tank No: 7  
Tank ID: 10629  
**Tank Status: Currently In Use**  
Tank Capacity: 10000  
Date Installed: 08/14/1990  
Substance: Gasoline  
Reported Release: Yes  
Close Type: Not reported  
Date Removed: Not reported  
Close Type: Not reported

Map ID  
Direction  
Distance  
Elevation

MAP FINDINGS

Site

Database(s)

EDR ID Number  
EPA ID Number

**FAST MART #23 (Continued)**

**U001297116**

Tank Material: Epoxy Coated Steel  
2nd Containmnt: Cathodically Protected  
Tank Lead Detection: Groundwater/Vapor Monitoring  
Overfill Protection: Yes  
Spill Prevention: Yes

Pipe:

Tank No: 7  
Tank Id: 10629  
Pipe Id: 7  
Pipe Status: Currently In Use  
Type Of Closure: Not reported  
Pipe Material Construction: Fiberglass Reinforced Plastic  
Secondary Pipe Material: Double-Walled  
Piping Type: Pressurized  
Pipe Leak Detection: Groundwater/Vapor Monitoring

Tank:

Tank No: 8  
Tank ID: 10630  
**Tank Status: Currently In Use**  
Tank Capacity: 10000  
Date Installed: 08/14/1990  
Substance: Gasoline  
Reported Release: Yes  
Close Type: Not reported  
Date Removed: Not reported  
Close Type: Not reported  
Tank Material: Epoxy Coated Steel  
2nd Containmnt: Cathodically Protected  
Tank Lead Detection: Groundwater/Vapor Monitoring  
Overfill Protection: Yes  
Spill Prevention: Yes

Pipe:

Tank No: 8  
Tank Id: 10630  
Pipe Id: 8  
Pipe Status: Currently In Use  
Type Of Closure: Not reported  
Pipe Material Construction: Fiberglass Reinforced Plastic  
Secondary Pipe Material: Double-Walled  
Piping Type: Pressurized  
Pipe Leak Detection: Groundwater/Vapor Monitoring

D27  
NW  
1/8-1/4  
0.145 mi.  
765 ft.

1119 30TH AVE  
GULFPORT, MS 39501

Site 6 of 13 in cluster D

EDR US Hist Auto Stat 1015159711  
N/A

Relative:  
Higher

EDR Historical Auto Stations:  
Name: 30TH AVE CHEVRON FOOD MART  
Year: 1999

Actual:  
20 ft.

Address: 1119 30TH AVE

Map ID  
 Direction  
 Distance  
 Elevation

MAP FINDINGS

Site

Database(s)

EDR ID Number  
 EPA ID Number

**(Continued)**

**1015159711**

Name: 30TH AVE CHEVRON FOOD MART  
 Year: 2000  
 Address: 1119 30TH AVE

Name: EXXON FAST TRAC  
 Year: 2010  
 Address: 1119 30TH AVE

**D28  
 NW  
 1/8-1/4  
 0.145 mi.  
 765 ft.**

**FAST TRAC NUMBER 23  
 1119 30TH AVENUE  
 GULFPORT, MS 39501  
 Site 7 of 13 in cluster D**

**FINDS 1016020018  
 N/A**

**Relative:  
 Higher**

FINDS:

Registry ID: 110044667731

**Actual:  
 20 ft.**

Environmental Interest/Information System

MS-ENSITE (Mississippi - Tools For Environmental Management And Protection Organizations). Mississippi Department of Environmental Quality (MDEQ) Office of Pollution Control's (OPC) maintains enSite. It is the electronic Environmental Site Information System that regulates compliance assurance, permitting, activity tracking, and maintenance of a single agency interest-link to definition master file.

**D29  
 NW  
 1/8-1/4  
 0.169 mi.  
 890 ft.**

**P T DELI # 1  
 3000 12TH STREET  
 GULFPORT, MS  
 Site 8 of 13 in cluster D**

**RGA LUST S116272519  
 N/A**

**Relative:  
 Higher**

RGA LUST:

2006 P T DELI # 1 3000 12TH STREET  
 2005 P T DELI # 1 3000 12TH STREET

**Actual:  
 22 ft.**

**D30  
 NW  
 1/8-1/4  
 0.169 mi.  
 890 ft.**

**P T DELI #1  
 3000 12TH STREET  
 GULFPORT, MS 39502  
 Site 9 of 13 in cluster D**

**LUST U001296343  
 UST N/A**

**Relative:  
 Higher**

Facility Id: 168  
 Facility Satus: Inactive  
 Lust Status: Closed  
 AIID: 18424  
 Event #: 1  
 Project Manager: Martha Martin  
 Date Of Report: 08/14/2002  
 Trust Fund Status: EUD  
 Confirmed On: 08/14/2002  
 NFA Date: 03/05/2003

**Actual:  
 22 ft.**

Map ID  
Direction  
Distance  
Elevation

MAP FINDINGS

Site

Database(s)

EDR ID Number  
EPA ID Number

**P T DELI #1 (Continued)**

**U001296343**

Facility Id: 168  
Facility Status: Inactive  
Lust Status: Open  
AIIID: 18424  
Event #: 2  
Project Manager: Martha Martin  
Date Of Report: 07/28/2003  
Trust Fund Status: STFS  
Confirmed On: 07/28/2003  
NFA Date: Not reported

Facility Id: 168  
Facility Status: Inactive  
Lust Status: Closed  
AIIID: 18424  
Event #: 3  
Project Manager: Michael Usry  
Date Of Report: 10/17/2006  
Trust Fund Status: Katrina  
Confirmed On: 12/20/2006  
NFA Date: 12/27/2006

**UST:**

Facility ID: 168  
Facility Status: Inactive  
Latitude: 30 21' 58.0000"  
Longitude: 89 5' 53.8000"  
Permanently Out of Use Tanks: 5  
Active Tanks: 0  
AIIID: 18424  
Owner Name: Giau Doan And Phuong Dang  
Owner Address: 3000 12th Street  
Owner Tele: (228)868-0003

**Tank:**

Tank No: 1  
Tank ID: 579  
**Tank Status: Permanently Out of Use**  
Tank Capacity: 8000  
Date Installed: 01/01/1978  
Substance: Gasoline  
Reported Release: Yes  
Close Type: Closed  
Date Removed: 09/22/1994  
Close Type: 09/23/1994  
Tank Material: Asphalt Coated or Bare Steel  
2nd Containmnt: None  
Tank Lead Detection: Groundwater/Vapor Monitoring  
Overfill Protection: No  
Spill Prevention: No

**Pipe:**

Tank No: 1  
Tank Id: 579  
Pipe Id: 1  
Pipe Status: Permanently Out of Use  
Type Of Closure: Closed

Map ID  
Direction  
Distance  
Elevation

MAP FINDINGS

Site

Database(s)

EDR ID Number  
EPA ID Number

**P T DELI #1 (Continued)**

**U001296343**

Pipe Material Construction: Bare/Galvanized Steel  
Secondary Pipe Material: None  
Piping Type: Safe Suction  
Pipe Leak Detection: N/A

Tank:

Tank No: 2  
Tank ID: 580  
**Tank Status: Permanently Out of Use**  
Tank Capacity: 6000  
Date Installed: 01/01/1978  
Substance: Gasoline  
Reported Release: Yes  
Close Type: Closed  
Date Removed: 09/23/1994  
Close Type: 09/23/1994  
Tank Material: Asphalt Coated or Bare Steel  
2nd Containmnt: None  
Tank Lead Detection: Groundwater/Vapor Monitoring  
Overfill Protection: No  
Spill Prevention: No

Pipe:

Tank No: 2  
Tank Id: 580  
Pipe Id: 2  
Pipe Status: Permanently Out of Use  
Type Of Closure: Closed  
Pipe Material Construction: Bare/Galvanized Steel  
Secondary Pipe Material: None  
Piping Type: Safe Suction  
Pipe Leak Detection: N/A

Tank:

Tank No: 3  
Tank ID: 581  
**Tank Status: Permanently Out of Use**  
Tank Capacity: 6000  
Date Installed: 01/01/1978  
Substance: Gasoline  
Reported Release: Yes  
Close Type: Closed  
Date Removed: 09/23/1994  
Close Type: 09/23/1994  
Tank Material: Asphalt Coated or Bare Steel  
2nd Containmnt: None  
Tank Lead Detection: Groundwater/Vapor Monitoring  
Overfill Protection: No  
Spill Prevention: No

Pipe:

Tank No: 3  
Tank Id: 581



Map ID  
Direction  
Distance  
Elevation

MAP FINDINGS

Site

Database(s)

EDR ID Number  
EPA ID Number

**P T DELI #1 (Continued)**

**U001296343**

Pipe Id: 3  
Pipe Status: Permanently Out of Use  
Type Of Closure: Closed  
Pipe Material Construction: Bare/Galvanized Steel  
Secondary Pipe Material: None  
Piping Type: Safe Suction  
Pipe Leak Detection: N/A

Tank:  
Tank No: 4  
Tank ID: 582  
**Tank Status: Permanently Out of Use**  
Tank Capacity: 8000  
Date Installed: 02/02/1995  
Substance: Gasoline  
Reported Release: Yes  
Close Type: Not reported  
Date Removed: 08/28/2005  
Close Type: 12/07/2010  
Tank Material: Composite (Steel w/ FRP)  
2nd Containmnt: None  
Tank Lead Detection: Automatic Tank Gauging  
Overfill Protection: Yes  
Spill Prevention: Yes

Pipe:  
Tank No: 4  
Tank Id: 582  
Pipe Id: 4  
Pipe Status: Permanently Out of Use  
Type Of Closure: Not reported  
Pipe Material Construction: Flexible Plastic  
Secondary Pipe Material: Double-Walled  
Piping Type: Pressurized  
Pipe Leak Detection: Groundwater/Vapor Monitoring

Tank:  
Tank No: 5  
Tank ID: 583  
**Tank Status: Permanently Out of Use**  
Tank Capacity: 8000  
Date Installed: 02/02/1995  
Substance: Gasoline  
Reported Release: Yes  
Close Type: Not reported  
Date Removed: 08/27/2005  
Close Type: 12/07/2010  
Tank Material: Composite (Steel w/ FRP)  
2nd Containmnt: None  
Tank Lead Detection: Automatic Tank Gauging  
Overfill Protection: Yes  
Spill Prevention: Yes

Map ID  
 Direction  
 Distance  
 Elevation

MAP FINDINGS

Site

Database(s)

EDR ID Number  
 EPA ID Number

**P T DELI #1 (Continued)**

**U001296343**

Pipe:  
 Tank No: 5  
 Tank Id: 583  
 Pipe Id: 5  
 Pipe Status: Permanently Out of Use  
 Type Of Closure: Not reported  
 Pipe Material Construction: Flexible Plastic  
 Secondary Pipe Material: Double-Walled  
 Piping Type: Pressurized  
 Pipe Leak Detection: Groundwater/Vapor Monitoring

**D31  
 NW  
 1/8-1/4  
 0.169 mi.  
 890 ft.**

**EARTH CONSULTING GROUP INC, PHILLIPS 66, GULFPORT  
 3000 12TH STREET  
 GULFPORT, MS 39501  
 Site 10 of 13 in cluster D**

**FINDS 1016037979  
 N/A**

**Relative:  
 Higher**

FINDS:

Registry ID: 110044610631

**Actual:  
 22 ft.**

Environmental Interest/Information System  
 MS-ENSITE (Mississippi - Tools For Environmental Management And Protection Organizations). Mississippi Department of Environmental Quality (MDEQ) Office of Pollution Control's (OPC) maintains enSite. It is the electronic Environmental Site Information System that that regulates compliance assurance, permitting, activity tracking, and maintenance of a single agency interest-link to definition master file.

**D32  
 NW  
 1/8-1/4  
 0.169 mi.  
 890 ft.**

**P T DELI #1  
 3000 12TH STREET  
 GULFPORT, MS  
 Site 11 of 13 in cluster D**

**RGA LUST S116272520  
 N/A**

**Relative:  
 Higher**

RGA LUST:

2012	P T DELI #1	3000 12TH STREET
2011	P T DELI #1	3000 12TH STREET
2010	P T DELI #1	3000 12TH STREET
2009	P T DELI #1	3000 12TH STREET
2008	P T DELI #1	3000 12TH STREET
2007	P T DELI #1	3000 12TH STREET

**Actual:  
 22 ft.**

MAP FINDINGS

Map ID  
 Direction  
 Distance  
 Elevation

Site

Database(s)

EDR ID Number  
 EPA ID Number

**D33**  
**NW**  
 1/8-1/4  
 0.169 mi.  
 890 ft.

**COASTAL ENERGY CO OF MISSISSIPPI**  
**3000 12TH STREET**  
**GULFPORT, MS**

**RGA LUST**    **S116268921**  
 N/A

**Site 12 of 13 in cluster D**

**Relative:**  
**Higher**

RGA LUST:

2004	COASTAL ENERGY CO OF MISSISSIPPI	3000 12TH STREET
2003	COASTAL ENERGY CO OF MISSISSIPPI	3000 12TH STREET
2002	COASTAL ENERGY CO OF MISSISSIPPI	3000 12TH STREET

**Actual:**  
 22 ft.

**D34**  
**NW**  
 1/8-1/4  
 0.180 mi.  
 948 ft.

**1223 30TH AVE**  
**GULFPORT, MS 39501**

**EDR US Hist Auto Stat**    **1015187016**  
 N/A

**Site 13 of 13 in cluster D**

**Relative:**  
**Higher**

EDR Historical Auto Stations:

Name:	AUTO SERVICE CTR
Year:	2003
Address:	1223 30TH AVE

**Actual:**  
 23 ft.

Name:	AUTO SERVICE CTR
Year:	2004
Address:	1223 30TH AVE

Name:	AUTO SERVICE CENTER
Year:	2005
Address:	1223 30TH AVE

**E35**  
**North**  
 1/8-1/4  
 0.188 mi.  
 992 ft.

**COLONIAL TRAILWAYS BUS STATION**  
**2805 13TH STREET**  
**GULFPORT, MS 39501**

**LUST**    **U001296898**  
**UST**    **N/A**

**Site 1 of 8 in cluster E**

**Relative:**  
**Higher**

Facility Id:	1684
Facility Satus:	Inactive
Lust Status:	Closed
AIID:	31083
Event #:	1
Project Manager:	Robert Huckaby
Date Of Report:	07/18/2001
Trust Fund Status:	EUD
Confirmed On:	07/11/2001
NFA Date:	07/23/2001

**Actual:**  
 23 ft.

UST:

Facility ID:	1684
Facility Status:	Inactive
Latitude:	30 22' 2.0000"
Longitude:	89 5' 44.0000"
Permanently Out of Use Tanks:	4
Active Tanks:	0
AIID:	31083
Owner Name:	Colonial Trailways
Owner Address:	400 South Royal Street
Owner Tele:	(251)433-1677

Map ID  
Direction  
Distance  
Elevation

MAP FINDINGS

Site

Database(s)

EDR ID Number  
EPA ID Number

COLONIAL TRAILWAYS BUS STATION (Continued)

U001296898

Tank:

Tank No: 1  
Tank ID: 3859  
**Tank Status: Permanently Out of Use**  
Tank Capacity: Unknown  
Date Installed: 01/01/1960  
Substance: Gasoline  
Reported Release: Yes  
Close Type: Closed  
Date Removed: 06/15/1985  
Close Type: 06/15/1985  
Tank Material: Asphalt Coated or Bare Steel  
2nd Containmnt: None  
Tank Lead Detection: N/A  
Overfill Protection: No  
Spill Prevention: No

Pipe:

Tank No: 1  
Tank Id: 3859  
Pipe Id: 1  
Pipe Status: Permanently Out of Use  
Type Of Closure: Closed  
Pipe Material Construction: Unknown  
Secondary Pipe Material: None  
Piping Type: N/A  
Pipe Leak Detection: Not Listed

Tank:

Tank No: 2  
Tank ID: 3860  
**Tank Status: Permanently Out of Use**  
Tank Capacity: Unknown  
Date Installed: 01/01/1960  
Substance: Gasoline  
Reported Release: Yes  
Close Type: Closed  
Date Removed: 06/15/1985  
Close Type: 06/15/1985  
Tank Material: Asphalt Coated or Bare Steel  
2nd Containmnt: None  
Tank Lead Detection: N/A  
Overfill Protection: No  
Spill Prevention: No

Pipe:

Tank No: 2  
Tank Id: 3860  
Pipe Id: 2  
Pipe Status: Permanently Out of Use  
Type Of Closure: Closed  
Pipe Material Construction: Unknown  
Secondary Pipe Material: None  
Piping Type: N/A  
Pipe Leak Detection: Not Listed

Map ID  
Direction  
Distance  
Elevation

MAP FINDINGS

Site

Database(s)

EDR ID Number  
EPA ID Number

COLONIAL TRAILWAYS BUS STATION (Continued)

U001296898

Tank:

Tank No: 3  
Tank ID: 3861  
**Tank Status: Permanently Out of Use**  
Tank Capacity: 4000  
Date Installed: 01/01/1960  
Substance: Gasoline  
Reported Release: Yes  
Close Type: Closed  
Date Removed: 06/15/1985  
Close Type: 06/15/1985  
Tank Material: Asphalt Coated or Bare Steel  
2nd Containmnt: None  
Tank Lead Detection: N/A  
Overfill Protection: No  
Spill Prevention: No

Pipe:

Tank No: 3  
Tank Id: 3861  
Pipe Id: 3  
Pipe Status: Permanently Out of Use  
Type Of Closure: Closed  
Pipe Material Construction: Unknown  
Secondary Pipe Material: None  
Piping Type: N/A  
Pipe Leak Detection: Not Listed

Tank:

Tank No: 4  
Tank ID: 3862  
**Tank Status: Permanently Out of Use**  
Tank Capacity: 1000  
Date Installed: 01/01/1960  
Substance: Gasoline  
Reported Release: Yes  
Close Type: Closed  
Date Removed: 06/15/1985  
Close Type: 06/15/1985  
Tank Material: Asphalt Coated or Bare Steel  
2nd Containmnt: None  
Tank Lead Detection: N/A  
Overfill Protection: No  
Spill Prevention: No

Pipe:

Tank No: 4  
Tank Id: 3862  
Pipe Id: 4  
Pipe Status: Permanently Out of Use  
Type Of Closure: Closed  
Pipe Material Construction: Unknown  
Secondary Pipe Material: None  
Piping Type: N/A  
Pipe Leak Detection: Not Listed

MAP FINDINGS

Map ID  
 Direction  
 Distance  
 Elevation

Site

Database(s)

EDR ID Number  
 EPA ID Number

**E36**  
 North  
 1/8-1/4  
 0.188 mi.  
 992 ft.

**COLONIAL TRAILWAYS BUS STATION**  
 2805 13TH STREET  
 GULFPORT, MS 39501

**FINDS** 1016019013  
 N/A

**Relative:**  
 Higher

FINDS:

Registry ID: 110044510320

**Actual:**  
 23 ft.

Environmental Interest/Information System

MS-ENSITE (Mississippi - Tools For Environmental Management And Protection Organizations). Mississippi Department of Environmental Quality (MDEQ) Office of Pollution Control's (OPC) maintains enSite. It is the electronic Environmental Site Information System that that regulates compliance assurance, permitting, activity tracking, and maintenance of a single agency interest-link to definition master file.

**E37**  
 North  
 1/8-1/4  
 0.188 mi.  
 992 ft.

**COLONIAL TRAILWAYS BUS STATION**  
 2805 13TH STREET  
 GULFPORT, MS

**RGA LUST** S116268987  
 N/A

Site 3 of 8 in cluster E

**Relative:**  
 Higher

RGA LUST:

2012	COLONIAL TRAILWAYS BUS STATION	2805 13TH STREET
2011	COLONIAL TRAILWAYS BUS STATION	2805 13TH STREET
2010	COLONIAL TRAILWAYS BUS STATION	2805 13TH STREET
2009	COLONIAL TRAILWAYS BUS STATION	2805 13TH STREET
2008	COLONIAL TRAILWAYS BUS STATION	2805 13TH STREET
2007	COLONIAL TRAILWAYS BUS STATION	2805 13TH STREET
2006	COLONIAL TRAILWAYS BUS STATION	2805 13TH STREET
2005	COLONIAL TRAILWAYS BUS STATION	2805 13TH STREET
2004	COLONIAL TRAILWAYS BUS STATION	2805 13TH STREET
2003	COLONIAL TRAILWAYS BUS STATION	2805 13TH STREET
2002	COLONIAL TRAILWAYS BUS STATION	2805 13TH STREET
2001	COLONIAL TRAILWAYS BUS STATION	2805 13TH STREET

**Actual:**  
 23 ft.

**E38**  
 North  
 1/8-1/4  
 0.201 mi.  
 1063 ft.

**MOSERS AUTO SERVICE**  
 2800 13TH STREET  
 GULFPORT, MS 39501

**RCRA-CESQG** 1004743237  
 MSD985971837

Site 4 of 8 in cluster E

**Relative:**  
 Higher

RCRA-CESQG:

Date form received by agency: 04/05/1991  
 Facility name: MOSERS AUTO SERVICE  
 Facility address: 2800 13TH STREET  
 GULFPORT, MS 39501  
 EPA ID: MSD985971837  
 Mailing address: 13TH STREET  
 GULFPORT, MS 39501  
 Contact: RICHARD MOSER  
 Contact address: 2800 13TH STREET  
 GULFPORT, MS 39501  
 Contact country: US  
 Contact telephone: (601) 864-4586

**Actual:**  
 23 ft.

Map ID  
Direction  
Distance  
Elevation

MAP FINDINGS

Site

Database(s)

EDR ID Number  
EPA ID Number

**MOSERS AUTO SERVICE (Continued)**

**1004743237**

Contact email: Not reported  
EPA Region: 04  
Classification: Conditionally Exempt Small Quantity Generator  
Description: Handler: generates 100 kg or less of hazardous waste per calendar month, and accumulates 1000 kg or less of hazardous waste at any time; or generates 1 kg or less of acutely hazardous waste per calendar month, and accumulates at any time: 1 kg or less of acutely hazardous waste; or 100 kg or less of any residue or contaminated soil, waste or other debris resulting from the cleanup of a spill, into or on any land or water, of acutely hazardous waste; or generates 100 kg or less of any residue or contaminated soil, waste or other debris resulting from the cleanup of a spill, into or on any land or water, of acutely hazardous waste during any calendar month, and accumulates at any time: 1 kg or less of acutely hazardous waste; or 100 kg or less of any residue or contaminated soil, waste or other debris resulting from the cleanup of a spill, into or on any land or water, of acutely hazardous waste

Owner/Operator Summary:

Owner/operator name: RICHARD MOSER  
Owner/operator address: 2800 13TH STREET  
GULFPORT, MS 39501  
Owner/operator country: Not reported  
Owner/operator telephone: (601) 864-4586  
Legal status: Private  
Owner/Operator Type: Owner  
Owner/Op start date: Not reported  
Owner/Op end date: Not reported

Handler Activities Summary:

U.S. importer of hazardous waste: No  
Mixed waste (haz. and radioactive): No  
Recycler of hazardous waste: No  
Transporter of hazardous waste: No  
Treater, storer or disposer of HW: No  
Underground injection activity: No  
On-site burner exemption: No  
Furnace exemption: No  
Used oil fuel burner: No  
Used oil processor: No  
User oil refiner: No  
Used oil fuel marketer to burner: No  
Used oil Specification marketer: No  
Used oil transfer facility: No  
Used oil transporter: No

. Waste code: D001  
. Waste name: IGNITABLE WASTE

. Waste code: F001  
. Waste name: THE FOLLOWING SPENT HALOGENATED SOLVENTS USED IN DEGREASING: TETRACHLOROETHYLENE, TRICHLORETHYLENE, METHYLENE CHLORIDE, 1,1,1-TRICHLOROETHANE, CARBON TETRACHLORIDE AND CHLORINATED FLUOROCARBONS; ALL SPENT SOLVENT MIXTURES/BLENDS USED IN DEGREASING CONTAINING, BEFORE USE, A TOTAL OF TEN PERCENT OR MORE (BY VOLUME) OF ONE OR MORE OF THE ABOVE HALOGENATED SOLVENTS OR THOSE SOLVENTS LISTED



Map ID  
Direction  
Distance  
Elevation

MAP FINDINGS

Site

Database(s)

EDR ID Number  
EPA ID Number

**MOSERS AUTO SERVICE (Continued)**

**1004743237**

IN F002, F004, AND F005; AND STILL BOTTOMS FROM THE RECOVERY OF THESE SPENT SOLVENTS AND SPENT SOLVENT MIXTURES.

Violation Status: No violations found

**E39**  
North  
1/8-1/4  
0.201 mi.  
1063 ft.

**K AND K PERFORMANCE**  
2800 13TH STREET  
GULFPORT, MS 39501  
Site 5 of 8 in cluster E

**FINDS 1016131963**  
N/A

**Relative:**  
**Higher**

FINDS:

Registry ID: 110002221355

**Actual:**  
23 ft.

Environmental Interest/Information System

MS-ENSITE (Mississippi - Tools For Environmental Management And Protection Organizations). Mississippi Department of Environmental Quality (MDEQ) Office of Pollution Control's (OPC) maintains enSite. It is the electronic Environmental Site Information System that regulates compliance assurance, permitting, activity tracking, and maintenance of a single agency interest-link to definition master file.

RCRAInfo is a national information system that supports the Resource Conservation and Recovery Act (RCRA) program through the tracking of events and activities related to facilities that generate, transport, and treat, store, or dispose of hazardous waste. RCRAInfo allows RCRA program staff to track the notification, permit, compliance, and corrective action activities required under RCRA.

**E40**  
North  
1/8-1/4  
0.201 mi.  
1063 ft.

**K & K PERFORMANCE SHOP**  
2800 13TH ST  
GULFPORT, MS 39501  
Site 6 of 8 in cluster E

**RCRA-CESQG 1004743354**  
**MSD985976000**

**Relative:**  
**Higher**

RCRA-CESQG:

Date form received by agency: 09/06/1993  
Facility name: K & K PERFORMANCE SHOP  
Facility address: 2800 13TH ST  
GULFPORT, MS 39501  
EPA ID: MSD985976000  
Mailing address: 13TH ST  
GULFPORT, MS 39501  
Contact: KEITH HELTON  
Contact address: 2800 13TH ST  
GULFPORT, MS 39501  
Contact country: US  
Contact telephone: (601) 867-2047  
Contact email: Not reported  
EPA Region: 04  
Classification: Conditionally Exempt Small Quantity Generator  
Description: Handler: generates 100 kg or less of hazardous waste per calendar month, and accumulates 1000 kg or less of hazardous waste at any time; or generates 1 kg or less of acutely hazardous waste per calendar

Map ID  
Direction  
Distance  
Elevation

MAP FINDINGS

Site

Database(s)

EDR ID Number  
EPA ID Number

**K & K PERFORMANCE SHOP (Continued)**

**1004743354**

month, and accumulates at any time: 1 kg or less of acutely hazardous waste; or 100 kg or less of any residue or contaminated soil, waste or other debris resulting from the cleanup of a spill, into or on any land or water, of acutely hazardous waste; or generates 100 kg or less of any residue or contaminated soil, waste or other debris resulting from the cleanup of a spill, into or on any land or water, of acutely hazardous waste during any calendar month, and accumulates at any time: 1 kg or less of acutely hazardous waste; or 100 kg or less of any residue or contaminated soil, waste or other debris resulting from the cleanup of a spill, into or on any land or water, of acutely hazardous waste

Owner/Operator Summary:

Owner/operator name: K&K PERFORMANCE SHOP  
Owner/operator address: 2800 13TH STREET  
GULFPORT, MS 39501  
Owner/operator country: Not reported  
Owner/operator telephone: (601) 867-2047  
Legal status: Private  
Owner/Operator Type: Owner  
Owner/Op start date: Not reported  
Owner/Op end date: Not reported

Handler Activities Summary:

U.S. importer of hazardous waste: No  
Mixed waste (haz. and radioactive): No  
Recycler of hazardous waste: No  
Transporter of hazardous waste: No  
Treater, storer or disposer of HW: No  
Underground injection activity: No  
On-site burner exemption: No  
Furnace exemption: No  
Used oil fuel burner: No  
Used oil processor: No  
User oil refiner: No  
Used oil fuel marketer to burner: No  
Used oil Specification marketer: No  
Used oil transfer facility: No  
Used oil transporter: No

. Waste code: D001  
. Waste name: IGNITABLE WASTE

. Waste code: F001  
. Waste name: THE FOLLOWING SPENT HALOGENATED SOLVENTS USED IN DEGREASING: TETRACHLOROETHYLENE, TRICHLOROETHYLENE, METHYLENE CHLORIDE, 1,1,1-TRICHLOROETHANE, CARBON TETRACHLORIDE AND CHLORINATED FLUOROCARBONS; ALL SPENT SOLVENT MIXTURES/BLENDS USED IN DEGREASING CONTAINING, BEFORE USE, A TOTAL OF TEN PERCENT OR MORE (BY VOLUME) OF ONE OR MORE OF THE ABOVE HALOGENATED SOLVENTS OR THOSE SOLVENTS LISTED IN F002, F004, AND F005; AND STILL BOTTOMS FROM THE RECOVERY OF THESE SPENT SOLVENTS AND SPENT SOLVENT MIXTURES.

Violation Status: No violations found

MAP FINDINGS

Map ID Direction Distance Elevation	Site	Database(s)	EDR ID Number EPA ID Number
<b>E41</b> North 1/8-1/4 0.201 mi. 1063 ft.	<b>MOSERS AUTO SERVICE</b> 2800 13TH STREET GULFPORT, MS 39501  Site 7 of 8 in cluster E	<b>FINDS</b>	<b>1016613168</b> N/A
<b>Relative: Higher</b>	<b>FINDS:</b>  Registry ID: 110002223503  Environmental Interest/Information System RCRAInfo is a national information system that supports the Resource Conservation and Recovery Act (RCRA) program through the tracking of events and activities related to facilities that generate, transport, and treat, store, or dispose of hazardous waste. RCRAInfo allows RCRA program staff to track the notification, permit, compliance, and corrective action activities required under RCRA.  MS-ENSITE (Mississippi - Tools For Environmental Management And Protection Organizations). Mississippi Department of Environmental Quality (MDEQ) Office of Pollution Control's (OPC) maintains enSite. It is the electronic Environmental Site Information System that regulates compliance assurance, permitting, activity tracking, and maintenance of a single agency interest-link to definition master file.		
<b>Actual: 23 ft.</b>			
<b>E42</b> North 1/8-1/4 0.218 mi. 1153 ft.	<b>1325 28TH AVENUE</b> 1325 28TH AVENUE GULFPORT, MS 39501  Site 8 of 8 in cluster E	<b>FINDS</b>	<b>1016003419</b> N/A
<b>Relative: Higher</b>	<b>FINDS:</b>  Registry ID: 110044414577  Environmental Interest/Information System MS-ENSITE (Mississippi - Tools For Environmental Management And Protection Organizations). Mississippi Department of Environmental Quality (MDEQ) Office of Pollution Control's (OPC) maintains enSite. It is the electronic Environmental Site Information System that regulates compliance assurance, permitting, activity tracking, and maintenance of a single agency interest-link to definition master file.		
<b>Actual: 23 ft.</b>			
<b>F43</b> NNE 1/8-1/4 0.219 mi. 1155 ft.	<b>ASTRO LINCOLN-MERCURY</b> 2617 13TH STREET GULFPORT, MS 39502  Site 1 of 5 in cluster F	<b>RCRA-CESQG</b>	<b>1004743048</b> <b>MSD985968221</b>
<b>Relative: Higher</b>	<b>RCRA-CESQG:</b> Date form received by agency: 02/12/1996 Facility name: ASTRO LINCOLN-MERCURY Facility address: 2617 13TH STREET GULFPORT, MS 39502		
<b>Actual: 20 ft.</b>			

Map ID  
Direction  
Distance  
Elevation

MAP FINDINGS

Site

Database(s)

EDR ID Number  
EPA ID Number

**ASTRO LINCOLN-MERCURY (Continued)**

**1004743048**

EPA ID: MSD985968221  
Mailing address: P. O. BOX 380  
GULFPORT, MS 39501  
Contact: FRANK MCCORMICK  
Contact address: 2617 13TH STREET  
GULFPORT, MS 39502  
Contact country: US  
Contact telephone: (601) 863-8762  
Contact email: Not reported  
EPA Region: 04  
Classification: Conditionally Exempt Small Quantity Generator  
Description: Handler: generates 100 kg or less of hazardous waste per calendar month, and accumulates 1000 kg or less of hazardous waste at any time; or generates 1 kg or less of acutely hazardous waste per calendar month, and accumulates at any time: 1 kg or less of acutely hazardous waste; or 100 kg or less of any residue or contaminated soil, waste or other debris resulting from the cleanup of a spill, into or on any land or water, of acutely hazardous waste; or generates 100 kg or less of any residue or contaminated soil, waste or other debris resulting from the cleanup of a spill, into or on any land or water, of acutely hazardous waste during any calendar month, and accumulates at any time: 1 kg or less of acutely hazardous waste; or 100 kg or less of any residue or contaminated soil, waste or other debris resulting from the cleanup of a spill, into or on any land or water, of acutely hazardous waste

**Owner/Operator Summary:**

Owner/operator name: ASTRO LINCOLN MERCURY OF MS  
Owner/operator address: 2617 13TH STREET  
GULFPORT, MS 39502  
Owner/operator country: Not reported  
Owner/operator telephone: (601) 863-8762  
Legal status: Private  
Owner/Operator Type: Owner  
Owner/Op start date: Not reported  
Owner/Op end date: Not reported

**Handler Activities Summary:**

U.S. importer of hazardous waste: No  
Mixed waste (haz. and radioactive): No  
Recycler of hazardous waste: No  
Transporter of hazardous waste: No  
Treater, storer or disposer of HW: No  
Underground injection activity: No  
On-site burner exemption: No  
Furnace exemption: No  
Used oil fuel burner: No  
Used oil processor: No  
User oil refiner: No  
Used oil fuel marketer to burner: No  
Used oil Specification marketer: No  
Used oil transfer facility: No  
Used oil transporter: No

. Waste code: D001  
. Waste name: IGNITABLE WASTE

Map ID  
Direction  
Distance  
Elevation

MAP FINDINGS

Site

Database(s)

EDR ID Number  
EPA ID Number

**ASTRO LINCOLN-MERCURY (Continued)**

**1004743048**

Violation Status: No violations found

**F44**  
**NNE**  
**1/8-1/4**  
**0.219 mi.**  
**1155 ft.**

**FORD DEALERSHIP**  
**2617 13TH STREET**  
**GULFPORT, MS 39501**  
**Site 2 of 5 in cluster F**

**UST** **U001294748**  
**N/A**

**Relative:**  
**Higher**

UST:  
Facility ID: 1425  
Facility Status: Inactive  
Latitude: 34 22' 17.4000"  
Longitude: 88 42' 27.3000"  
Permanently Out of Use Tanks: 1  
Active Tanks: 0  
AIID: 4659  
Owner Name: Bubba Oustalet Investment Company  
Owner Address: 2617 13th Street  
Owner Tele: (228)863-5525

**Actual:**  
**20 ft.**

Tank:  
Tank No: 1  
Tank ID: 3311  
**Tank Status: Permanently Out of Use**  
Tank Capacity: 1000  
Date Installed: 01/01/1936  
Substance: Used Oil  
Reported Release: Not reported  
Close Type: Closed  
Date Removed: 01/01/1982  
Close Type: 01/01/1982  
Tank Material: Unknown  
2nd Containmnt: None  
Tank Lead Detection: N/A  
Overfill Protection: No  
Spill Prevention: No

**F45**  
**NNE**  
**1/8-1/4**  
**0.219 mi.**  
**1155 ft.**

**ASTRO LINCOLN MERCURY**  
**2617 13TH STREET**  
**GULFPORT, MS 39501**  
**Site 3 of 5 in cluster F**

**FINDS** **1016632825**  
**N/A**

**Relative:**  
**Higher**

FINDS:  
Registry ID: 110002221667

**Actual:**  
**20 ft.**

Environmental Interest/Information System  
RCRAInfo is a national information system that supports the Resource Conservation and Recovery Act (RCRA) program through the tracking of events and activities related to facilities that generate, transport, and treat, store, or dispose of hazardous waste. RCRAInfo allows RCRA program staff to track the notification, permit, compliance, and corrective action activities required under RCRA.

MS-ENSITE (Mississippi - Tools For Environmental Management And Protection Organizations). Mississippi Department of Environmental

Map ID  
Direction  
Distance  
Elevation

MAP FINDINGS

Site

Database(s)

EDR ID Number  
EPA ID Number

**ASTRO LINCOLN MERCURY (Continued)**

**1016632825**

Quality (MDEQ) Office of Pollution Control's (OPC) maintains enSite. It is the electronic Environmental Site Information System that that regulates compliance assurance, permitting, activity tracking, and maintenance of a single agency interest-link to definition master file.

**G46**  
**NE**  
**1/8-1/4**  
**0.229 mi.**  
**1207 ft.**

**PO BOX 1689 ON EAST PIER, INTERSECT. OF HWY 90 AND HWY 49**  
**GULFPORT, MS**  
**Site 1 of 3 in cluster G**

**ERNS 90164407**  
**N/A**

**Relative:**  
**Higher**

[Click this hyperlink](#) while viewing on your computer to access additional ERNS detail in the EDR Site Report.

**Actual:**  
**16 ft.**  
**G47**  
**NE**  
**1/8-1/4**  
**0.230 mi.**  
**1215 ft.**

**WHITNEY NATIONAL BANK**  
**1300 25TH AVENUE**  
**GULFPORT, MS 39501**  
**Site 2 of 3 in cluster G**

**FINDS 1016013480**  
**N/A**

**Relative:**  
**Higher**

**FINDS:**

Registry ID: 110044601561

**Actual:**  
**16 ft.**

Environmental Interest/Information System

MS-ENSITE (Mississippi - Tools For Environmental Management And Protection Organizations). Mississippi Department of Environmental Quality (MDEQ) Office of Pollution Control's (OPC) maintains enSite. It is the electronic Environmental Site Information System that that regulates compliance assurance, permitting, activity tracking, and maintenance of a single agency interest-link to definition master file.

**H48**  
**NNW**  
**1/8-1/4**  
**0.233 mi.**  
**1228 ft.**

**AMERIPRIDE SERVICES**  
**1329 29TH AVENUE**  
**GULFPORT, MS 39501**  
**Site 1 of 3 in cluster H**

**FINDS 1017364096**  
**N/A**

**Relative:**  
**Higher**

**FINDS:**

Registry ID: 110060281840

**Actual:**  
**26 ft.**

Environmental Interest/Information System

US EPA Assessment, Cleanup and Redevelopment Exchange System (ACRES) is an federal online database for Brownfields Grantees to electronically submit data directly to EPA.

Map ID  
 Direction  
 Distance  
 Elevation

MAP FINDINGS

Site

Database(s)

EDR ID Number  
 EPA ID Number

**H49**  
**NNW**  
**1/8-1/4**  
**0.233 mi.**  
**1228 ft.**

**AMERIPRIDE SERVICES**  
**1329 29TH AVENUE**  
**GULFPORT, MS 39501**

**US BROWNFIELDS**    **1016679601**  
 N/A

**Site 2 of 3 in cluster H**

**Relative:**  
**Higher**

US BROWNFIELDS:

**Actual:**  
**26 ft.**

Recipient name: Grant type: Property name: Property #: Parcel size: Property Description:  Latitude: Longitude: HCM label: Map scale: Point of reference: Datum: ACRES property ID: Start date: Completed date: Acres cleaned up: Cleanup funding: Cleanup funding source: Assessment funding: Assessment funding source: Redevelopment funding: Redev. funding source: Redev. funding entity name: Redevelopment start date: Assessment funding entity: Cleanup funding entity: Grant type: Accomplishment type: Accomplishment count: Cooperative agreement #: Ownership entity: Current owner: Did owner change: Cleanup required: Video available: Photo available: Institutional controls required: IC Category proprietary controls: IC cat. info. devices: IC cat. gov. controls: IC cat. enforcement permit tools: IC in place date: IC in place: State/tribal program date: State/tribal program ID: State/tribal NFA date: Air contaminated:	Gulfport, City of Assessment AMERIPRIDE SERVICES 0811L-01-015.000 .38 Unoccupied property with ten groundwater monitor wells. Previous use as machine shop, Coca-Cola bottling, laundry company, vehicle maintenance shop. Most recent groundwater sampling event performed in January 2012 indicated trichloroethene concentrations in groundwater exceeding the Mississippi Department of Environmental Quality target remedial goal.  30.3679166 -89.0963055 Address Matching-House Number Not reported Entrance Point of a Facility or Station North American Datum of 1983 172861 Not reported Not reported Not reported Not reported Not reported 3967 US EPA - Brownfields Assessment Cooperative Agreement Not reported Not reported Not reported Not reported EPA Not reported H Phase I Environmental Assessment 1 95482611 Private AmeriPride Services, Inc. N Unknown No Yes U Not reported Not reported Not reported Not reported Not reported No Not reported Not reported Not reported Not reported Not reported
---	---



Map ID  
Direction  
Distance  
Elevation

MAP FINDINGS

Site

Database(s)

EDR ID Number  
EPA ID Number

**AMERIPRIDE SERVICES (Continued)**

**1016679601**

Air cleaned:	Not reported
Asbestos found:	Not reported
Asbestos cleaned:	Not reported
Controlled substance found:	Not reported
Controlled substance cleaned:	Not reported
Drinking water affected:	Not reported
Drinking water cleaned:	Not reported
Groundwater affected:	Not reported
Groundwater cleaned:	Not reported
Lead contaminant found:	Not reported
Lead cleaned up:	Not reported
No media affected:	Not reported
Unknown media affected:	Y
Other cleaned up:	Not reported
Other metals found:	Not reported
Other metals cleaned:	Not reported
Other contaminants found:	Not reported
Other contaminants found description:	Not reported
PAHs found:	Not reported
PAHs cleaned up:	Not reported
PCBs found:	Not reported
PCBs cleaned up:	Not reported
Petro products found:	Not reported
Petro products cleaned:	Not reported
Sediments found:	Not reported
Sediments cleaned:	Not reported
Soil affected:	Not reported
Soil cleaned up:	Not reported
Surface water cleaned:	Not reported
VOCs found:	Not reported
VOCs cleaned:	Not reported
Cleanup other description:	Not reported
Num. of cleanup and re-dev. jobs:	Not reported
Past use greenspace acreage:	Not reported
Past use residential acreage:	Not reported
Past use commercial acreage:	Not reported
Past use industrial acreage:	.38
Future use greenspace acreage:	Not reported
Future use residential acreage:	Not reported
Future use commercial acreage:	Not reported
Future use industrial acreage:	Not reported
Greenspace acreage and type:	Not reported
Superfund Fed. landowner flag:	Not reported
Arsenic cleaned up:	Not reported
Cadmium cleaned up:	Not reported
Chromium cleaned up:	Not reported
Copper cleaned up:	Not reported
Iron cleaned up:	Not reported
mercury cleaned up:	Not reported
nickel cleaned up:	Not reported
No clean up:	Not reported
Pesticides cleaned up:	Not reported
Selenium cleaned up:	Not reported
SVOCs cleaned up:	Not reported
Unknown clean up:	Not reported
Arsenic contaminant found:	Not reported
Cadmium contaminant found:	Not reported

Map ID  
 Direction  
 Distance  
 Elevation

MAP FINDINGS

Site

Database(s)

EDR ID Number  
 EPA ID Number

**AMERIPRIDE SERVICES (Continued)**

**1016679601**

Chromium contaminant found: Not reported  
 Copper contaminant found: Not reported  
 Iron contaminant found: Not reported  
 Mercury contaminant found: Not reported  
 Nickel contaminant found: Not reported  
 No contaminant found: Not reported  
 Pesticides contaminant found: Not reported  
 Selenium contaminant found: Not reported  
 SVOCs contaminant found: Not reported  
 Unknown contaminant found: Not reported  
 Future Use: Multistory Not reported  
 Media affected Bluiding Material: Not reported  
 Media affected indoor air: Not reported  
 Building material media cleaned up: Not reported  
 Indoor air media cleaned up: Not reported  
 Unknown media cleaned up: Not reported  
 Past Use: Multistory Not reported

**I50  
 NNW  
 1/8-1/4  
 0.234 mi.  
 1233 ft.**

**MACS QUICK STOP  
 1301 30TH AVENUE  
 GULFPORT, MS 39501**

**FINDS 1016020148  
 N/A**

**Site 1 of 7 in cluster I**

**Relative:  
 Higher**

FINDS:

Registry ID: 110044624671

**Actual:  
 23 ft.**

Environmental Interest/Information System

MS-ENSITE (Mississippi - Tools For Environmental Management And Protection Organizations). Mississippi Department of Environmental Quality (MDEQ) Office of Pollution Control's (OPC) maintains enSite. It is the electronic Environmental Site Information System that that regulates compliance assurance, permitting, activity tracking, and maintenance of a single agency interest-link to definition master file.

**I51  
 NNW  
 1/8-1/4  
 0.234 mi.  
 1233 ft.**

**MAC'S QUICK STOP  
 1301 30TH AVENUE  
 GULFPORT, MS**

**RGA LUST S116271760  
 N/A**

**Site 2 of 7 in cluster I**

**Relative:  
 Higher**

RGA LUST:

2012	MAC'S QUICK STOP	1301 30TH AVENUE
2011	MAC'S QUICK STOP	1301 30TH AVENUE
2010	MAC'S QUICK STOP	1301 30TH AVENUE
2009	MAC'S QUICK STOP	1301 30TH AVENUE
2008	MAC'S QUICK STOP	1301 30TH AVENUE
2007	MAC'S QUICK STOP	1301 30TH AVENUE
2006	MAC'S QUICK STOP	1301 30TH AVENUE
2005	MAC'S QUICK STOP	1301 30TH AVENUE
2004	MAC'S QUICK STOP	1301 30TH AVENUE
2003	MAC'S QUICK STOP	1301 30TH AVENUE
2002	MAC'S QUICK STOP	1301 30TH AVENUE

**Actual:  
 23 ft.**

Map ID  
Direction  
Distance  
Elevation

MAP FINDINGS

Site

Database(s)

EDR ID Number  
EPA ID Number

MAC'S QUICK STOP (Continued)

S116271760

2001 MAC'S QUICK STOP 1301 30TH AVENUE  
2000 MAC'S QUICK STOP 1301 30TH AVENUE  
1999 MAC'S QUICK STOP 1301 30TH AVENUE  
1998 MAC'S QUICK STOP 1301 30TH AVENUE

I52  
NNW  
1/8-1/4  
0.234 mi.  
1233 ft.

MAC'S QUICK STOP  
1301 30TH AVENUE  
GULFPORT, MS 39501  
Site 3 of 7 in cluster I

LUST U001297606  
UST N/A

Relative:  
Higher

Facility Id: 4478  
Facility Status: Inactive  
Lust Status: Closed  
AIID: 26155  
Event #: 1  
Project Manager: Heather Pitts  
Date Of Report: 11/06/1997  
Trust Fund Status: STFS  
Confirmed On: 10/13/1997  
NFA Date: 03/21/2003

Actual:  
23 ft.

UST:

Facility ID: 4478  
Facility Status: Inactive  
Latitude: 30 22' 2.5900"  
Longitude: 89 5' 53.0600"  
Permanently Out of Use Tanks: 2  
Active Tanks: 0  
AIID: 26155  
Owner Name: Thanh Peter Huynh  
Owner Address: 1301 30th Avenue  
Owner Tele: (228)832-5056

Tank:

Tank No: 1  
Tank ID: 11216  
**Tank Status: Permanently Out of Use**  
Tank Capacity: 8000  
Date Installed: 01/01/1981  
Substance: Gasoline  
Reported Release: Yes  
Close Type: Closed  
Date Removed: 12/21/1998  
Close Type: 12/22/1999  
Tank Material: Asphalt Coated or Bare Steel  
2nd Containmnt: None  
Tank Lead Detection: Groundwater/Vapor Monitoring  
Overfill Protection: No  
Spill Prevention: No

Pipe:

Tank No: 1  
Tank Id: 11216  
Pipe Id: 1  
Pipe Status: Permanently Out of Use  
Type Of Closure: Closed

Map ID  
Direction  
Distance  
Elevation

MAP FINDINGS

Site

Database(s)

EDR ID Number  
EPA ID Number

**MAC'S QUICK STOP (Continued)**

**U001297606**

Pipe Material Construction: Bare/Galvanized Steel  
Secondary Pipe Material: None  
Piping Type: N/A  
Pipe Leak Detection: Groundwater/Vapor Monitoring

**Tank:**

Tank No: 2  
Tank ID: 11217  
**Tank Status: Permanently Out of Use**  
Tank Capacity: 8000  
Date Installed: 01/01/1981  
Substance: Gasoline  
Reported Release: Yes  
Close Type: Closed  
Date Removed: 12/21/1998  
Close Type: 12/22/1999  
Tank Material: Asphalt Coated or Bare Steel  
2nd Containmnt: None  
Tank Lead Detection: Groundwater/Vapor Monitoring  
Overfill Protection: No  
Spill Prevention: No

**Pipe:**

Tank No: 2  
Tank Id: 11217  
Pipe Id: 2  
Pipe Status: Permanently Out of Use  
Type Of Closure: Closed  
Pipe Material Construction: Bare/Galvanized Steel  
Secondary Pipe Material: None  
Piping Type: N/A  
Pipe Leak Detection: Groundwater/Vapor Monitoring

**G53  
NE  
1/8-1/4  
0.234 mi.  
1236 ft.**

**BALCH & BINGHAM, LLP, LAW OFFICE  
1314 25TH STREET  
GULFPORT, MS 39501**

**ASBESTOS S117683051  
N/A**

**Site 3 of 3 in cluster G**

**Relative:  
Higher**

**ASBESTOS:**

AI ID: 67284  
SR No: 29  
City: GULFPORT  
County: Harrison  
ACT Type: Renovation  
Branch: Air Demolition and Renovation  
SIC: NONE SELECTED  
Basin: None  
Start Date: 02/17/2015  
Start Date 1: 02/04/2015  
Date End: 01/01/1900  
Mailing Address: PO Box 130 Gulfport, MS 39501  
Office of Pollution Control Name: Not reported  
Office of Pollution Control Assignment: Not reported  
Office of Pollution Control Phone: Not reported

**Actual:  
16 ft.**

Map ID  
Direction  
Distance  
Elevation

MAP FINDINGS

Site

Database(s)

EDR ID Number  
EPA ID Number

**BALCH & BINGHAM, LLP, LAW OFFICE (Continued)**

**S117683051**

AI ID: 67284  
SR No: 32  
City: GULFPORT  
County: Harrison  
ACT Type: Renovation  
Branch: Air Demolition and Renovation  
SIC: NONE SELECTED  
Basin: None  
Start Date: 02/17/2015  
Start Date 1: 02/04/2015  
Date End: 01/01/1900  
Mailing Address: PO Box 130 Gulfport, MS 39501  
Office of Pollution Control Name: Not reported  
Office of Pollution Control Assignment: Not reported  
Office of Pollution Control Phone: Not reported

I54  
NNW  
1/8-1/4  
0.238 mi.  
1255 ft.

**AMERIPRIDE LINEN & APPAREL SERVICES**

**SHWS S107035326**  
**VCP N/A**

**GULFPORT, MS**

**Site 4 of 7 in cluster I**

**Relative:**  
**Higher**

SHWS:  
Lat/Long (dms): 30 22 3 / 89 5 51  
Site Size (acres): <1  
EPA ID: Not reported  
Project Manager: Wallace, Thomas  
**Status: SNFA**  
State No Further Action Date: 05/06/2015  
Federal: Not reported  
Federal No Further Action Date: Not reported  
Soil Contamination: No  
Surface Water Contamination: No  
Ground Water Contamination: Yes  
Remediation Type: Not reported  
Surface Water Remediation: Not reported  
GW Remediation Type: Not reported  
Maj. Contaminant: TCE  
High Concentration: 4.30E-02  
High Concentration Units: mg/L  
Institutional Control: Not reported  
Engineering Control: Not reported  
Voluntary Cleanups: VEP

VCP:

Voluntary Cleanup VEP or BF: VEP

MAP FINDINGS

Map ID Direction Distance Elevation		Database(s)	EDR ID Number EPA ID Number
--	--	-------------	--------------------------------

<b>I55</b> <b>NNW</b> <b>1/8-1/4</b> <b>0.239 mi.</b> <b>1261 ft.</b>	<b>AMERIPRIDE LINEN AND APPAREL SERVICES</b> <b>1316 30TH AVENUE</b> <b>GULFPORT, MS 39501</b>  <b>Site 5 of 7 in cluster I</b>	<b>FINDS</b>	<b>1016619650</b> <b>N/A</b>
<b>Relative:</b> <b>Higher</b>	<b>FINDS:</b>  Registry ID: 110002215736  Environmental Interest/Information System RCRAInfo is a national information system that supports the Resource Conservation and Recovery Act (RCRA) program through the tracking of events and activities related to facilities that generate, transport, and treat, store, or dispose of hazardous waste. RCRAInfo allows RCRA program staff to track the notification, permit, compliance, and corrective action activities required under RCRA.  MS-ENSITE (Mississippi - Tools For Environmental Management And Protection Organizations). Mississippi Department of Environmental Quality (MDEQ) Office of Pollution Control's (OPC) maintains enSite. It is the electronic Environmental Site Information System that that regulates compliance assurance, permitting, activity tracking, and maintenance of a single agency interest-link to definition master file.		
<b>Actual:</b> <b>23 ft.</b>			

<b>I56</b> <b>NNW</b> <b>1/8-1/4</b> <b>0.239 mi.</b> <b>1261 ft.</b>	<b>AMERICAN LINEN</b> <b>1316 30TH AVENUE</b> <b>GULFPORT, MS 39501</b>  <b>Site 6 of 7 in cluster I</b>	<b>RCRA-CESQG</b>	<b>1004743594</b> <b>MSR000000356</b>
<b>Relative:</b> <b>Higher</b>	<b>RCRA-CESQG:</b> Date form received by agency: 03/24/1995 Facility name: AMERICAN LINEN Facility address: 1316 30TH AVENUE GULFPORT, MS 39501  EPA ID: MSR000000356 Mailing address: 30TH AVENUE GULFPORT, MS 39501  Contact: SAMUEL HOLMES Contact address: 1316 30TH AVENUE GULFPORT, MS 39501  Contact country: US Contact telephone: (601) 863-7272 Contact email: Not reported EPA Region: 04 Land type: Private Classification: Conditionally Exempt Small Quantity Generator Description: Handler: generates 100 kg or less of hazardous waste per calendar month, and accumulates 1000 kg or less of hazardous waste at any time; or generates 1 kg or less of acutely hazardous waste per calendar month, and accumulates at any time: 1 kg or less of acutely hazardous waste; or 100 kg or less of any residue or contaminated soil, waste or other debris resulting from the cleanup of a spill, into or on any land or water, of acutely hazardous waste; or generates 100 kg or less of any residue or contaminated soil, waste or other debris resulting from the cleanup of a spill, into or on any land or water, of acutely hazardous waste during any calendar month, and accumulates at any		
<b>Actual:</b> <b>23 ft.</b>			

Map ID  
Direction  
Distance  
Elevation

MAP FINDINGS

Site

Database(s)

EDR ID Number  
EPA ID Number

**AMERICAN LINEN (Continued)**

**1004743594**

time: 1 kg or less of acutely hazardous waste; or 100 kg or less of any residue or contaminated soil, waste or other debris resulting from the cleanup of a spill, into or on any land or water, of acutely hazardous waste

Owner/Operator Summary:

Owner/operator name: AMERICAN LINEN  
Owner/operator address: 1316 30TH AVENUE  
GULFPORT, MS 39501  
Owner/operator country: Not reported  
Owner/operator telephone: (601) 863-7272  
Legal status: Private  
Owner/Operator Type: Owner  
Owner/Op start date: Not reported  
Owner/Op end date: Not reported

Handler Activities Summary:

U.S. importer of hazardous waste: No  
Mixed waste (haz. and radioactive): No  
Recycler of hazardous waste: No  
Transporter of hazardous waste: No  
Treater, storer or disposer of HW: No  
Underground injection activity: No  
On-site burner exemption: No  
Furnace exemption: No  
Used oil fuel burner: No  
Used oil processor: No  
User oil refiner: No  
Used oil fuel marketer to burner: No  
Used oil Specification marketer: No  
Used oil transfer facility: No  
Used oil transporter: No

. Waste code: D001  
. Waste name: IGNITABLE WASTE

Violation Status: No violations found

Evaluation Action Summary:

Evaluation date: 06/01/2007  
Evaluation: COMPLIANCE EVALUATION INSPECTION ON-SITE  
Area of violation: Not reported  
Date achieved compliance: Not reported  
Evaluation lead agency: State

Evaluation date: 05/19/2005  
Evaluation: COMPLIANCE EVALUATION INSPECTION ON-SITE  
Area of violation: Not reported  
Date achieved compliance: Not reported  
Evaluation lead agency: State



MAP FINDINGS

Map ID  
Direction  
Distance  
Elevation

Site

Database(s)

EDR ID Number  
EPA ID Number

**I57**  
**NNW**  
**1/8-1/4**  
**0.239 mi.**  
**1261 ft.**

**AMERICAN LINEN SUPPLY COMPANY**  
**1316 30TH AVENUE**  
**GULFPORT, MS 39501**

**UST**    **U001294790**  
**N/A**

**Site 7 of 7 in cluster I**

**Relative:**  
**Higher**

UST:

Facility ID: 1666  
Facility Status: Inactive  
Latitude: 30 22' 3.0000"  
Longitude: 89 5' 51.0000"  
Permanently Out of Use Tanks: 4  
Active Tanks: 0  
AIID: 30344  
Owner Name: American Linen Supply Company  
Owner Address: 1316 30th Avenue  
Owner Tele: (228)863-7272

**Actual:**  
**23 ft.**

Tank:

Tank No: 1  
Tank ID: 3791  
**Tank Status: Permanently Out of Use**  
Tank Capacity: 4000  
Date Installed: 01/01/1960  
Substance: Gasoline  
Reported Release: Not reported  
Close Type: Closed  
Date Removed: 12/01/1988  
Close Type: 12/01/1988  
Tank Material: Asphalt Coated or Bare Steel  
2nd Containmnt: None  
Tank Lead Detection: N/A  
Overfill Protection: No  
Spill Prevention: No

Pipe:

Tank No: 1  
Tank Id: 3791  
Pipe Id: 1  
Pipe Status: Permanently Out of Use  
Type Of Closure: Closed  
Pipe Material Construction: Bare/Galvanized Steel  
Secondary Pipe Material: None  
Piping Type: N/A  
Pipe Leak Detection: Not Listed

Tank:

Tank No: 2  
Tank ID: 3792  
**Tank Status: Permanently Out of Use**  
Tank Capacity: 600  
Date Installed: 01/01/1955  
Substance: Used Oil  
Reported Release: Not reported  
Close Type: Closed  
Date Removed: 01/01/1968  
Close Type: 01/01/1968

Map ID  
Direction  
Distance  
Elevation

MAP FINDINGS

Site

Database(s)

EDR ID Number  
EPA ID Number

AMERICAN LINEN SUPPLY COMPANY (Continued)

U001294790

Tank Material: Asphalt Coated or Bare Steel  
2nd Containmnt: None  
Tank Lead Detection: N/A  
Overfill Protection: No  
Spill Prevention: No

Tank:

Tank No: 3  
Tank ID: 3793  
**Tank Status: Permanently Out of Use**  
Tank Capacity: 600  
Date Installed: 01/01/1955  
Substance: Gasoline  
Reported Release: Not reported  
Close Type: Closed  
Date Removed: 06/01/1987  
Close Type: 06/01/1987  
Tank Material: Asphalt Coated or Bare Steel  
2nd Containmnt: None  
Tank Lead Detection: N/A  
Overfill Protection: No  
Spill Prevention: No

Pipe:

Tank No: 3  
Tank Id: 3793  
Pipe Id: 3  
Pipe Status: Permanently Out of Use  
Type Of Closure: Closed  
Pipe Material Construction: Bare/Galvanized Steel  
Secondary Pipe Material: None  
Piping Type: N/A  
Pipe Leak Detection: Not Listed

Tank:

Tank No: 4  
Tank ID: 3794  
**Tank Status: Permanently Out of Use**  
Tank Capacity: 600  
Date Installed: 01/01/1955  
Substance: Gasoline  
Reported Release: Not reported  
Close Type: Closed  
Date Removed: 01/01/1978  
Close Type: 01/01/1978  
Tank Material: Asphalt Coated or Bare Steel  
2nd Containmnt: None  
Tank Lead Detection: N/A  
Overfill Protection: No  
Spill Prevention: No

Pipe:

Tank No: 4  
Tank Id: 3794

Map ID  
 Direction  
 Distance  
 Elevation

MAP FINDINGS

Site

Database(s)

EDR ID Number  
 EPA ID Number

**AMERICAN LINEN SUPPLY COMPANY (Continued)**

**U001294790**

Pipe Id: 4  
 Pipe Status: Permanently Out of Use  
 Type Of Closure: Closed  
 Pipe Material Construction: Bare/Galvanized Steel  
 Secondary Pipe Material: None  
 Piping Type: N/A  
 Pipe Leak Detection: Not Listed

**H58  
 NNW  
 1/8-1/4  
 0.243 mi.  
 1282 ft.**

**HIGH TECH SERVICES**

**SHWS S111739349**

**GULFPORT, MS**

**N/A**

**Site 3 of 3 in cluster H**

**Relative:  
 Higher**

SHWS:  
 Lat/Long (dms): 30 22 3 / 89 5 51  
 Site Size (acres): <1  
 EPA ID: Not reported  
 Project Manager: Not reported  
**Status: Not reported**  
 State No Further Action Date: Not reported  
 Federal: Not reported  
 Federal No Further Action Date: Not reported  
 Soil Contamination: No  
 Surface Water Contamination: No  
 Ground Water Contamination: Yes  
 Remediation Type: Not reported  
 Surface Water Remediation: Not reported  
 GW Remediation Type: Not reported  
 Maj. Contaminant: TCE  
 High Concentration: 4.50E+04  
 High Concentration Units: mg/L  
 Institutional Control: Not reported  
 Engineering Control: Not reported  
 Voluntary Cleanups: Not reported

**J59  
 NNE  
 1/8-1/4  
 0.248 mi.  
 1310 ft.**

**BARRETTS CLEANERS**

**SHWS S112272434**

**GULFPORT, MS**

**N/A**

**Site 1 of 5 in cluster J**

**Relative:  
 Higher**

SHWS:  
 Lat/Long (dms): 30 22 4 / 89 5 41  
 Site Size (acres): 1  
 EPA ID: Not reported  
 Project Manager: McKercher, Willie  
**Status: SNFA**  
 State No Further Action Date: 12/11/2013  
 Federal: Not reported  
 Federal No Further Action Date: Not reported  
 Soil Contamination: Yes  
 Surface Water Contamination: No  
 Ground Water Contamination: Yes  
 Remediation Type: Not reported

**Actual:  
 23 ft.**

Map ID  
Direction  
Distance  
Elevation

MAP FINDINGS

Site

Database(s)

EDR ID Number  
EPA ID Number

**BARRETT'S CLEANERS (Continued)**

**S112272434**

Surface Water Remediation: Not reported  
GW Remediation Type: Not reported  
Maj. Contaminant: TPH-GRO  
High Concentration: 2.66E+03  
High Concentration Units: mg/kg  
Institutional Control: Not reported  
Engineering Control: Not reported  
Voluntary Cleanups: Not reported

**F60**  
**NNE**  
**1/8-1/4**  
**0.248 mi.**  
**1311 ft.**

**MDOT - AMERIPRIDE LINENS**

**SHWS S106593184**  
**N/A**

**GULFPORT, MS**

**Site 4 of 5 in cluster F**

**Relative:**  
**Higher**

SHWS:  
Lat/Long (dms): 30 22 3 / 89 5 38  
Site Size (acres): <1  
EPA ID: Not reported  
Project Manager: Wallace, Thomas  
**Status: SNFA/Reopened**  
State No Further Action Date: 02/16/2005  
Federal: Not reported  
Federal No Further Action Date: Not reported  
Soil Contamination: No  
Surface Water Contamination: No  
Ground Water Contamination: No  
Remediation Type: Not reported  
Surface Water Remediation: Not reported  
GW Remediation Type: Not reported  
Maj. Contaminant: NO DATA  
High Concentration: Not reported  
High Concentration Units: Not reported  
Institutional Control: Not reported  
Engineering Control: Not reported  
Voluntary Cleanups: Not reported

**Actual:**  
**23 ft.**

**F61**  
**NE**  
**1/4-1/2**  
**0.251 mi.**  
**1326 ft.**

**POB 40**  
**GULFPORT, MS 39501**

**ERNS 2004724528**  
**N/A**

**Site 5 of 5 in cluster F**

**Relative:**  
**Higher**

[Click this hyperlink](#) while viewing on your computer to access additional ERNS detail in the EDR Site Report.

**Actual:**  
**20 ft.**

Map ID  
 Direction  
 Distance  
 Elevation

MAP FINDINGS

Site

Database(s)

EDR ID Number  
 EPA ID Number

**J62**  
**North**  
**1/4-1/2**  
**0.270 mi.**  
**1425 ft.**

**FORMER BARRETT CLEANERS**  
**2711 14TH STREET**  
**GULFPORT, MS 39506**

**Site 2 of 5 in cluster J**

**US BROWNFIELDS**    **1016456723**  
 N/A

**Relative:**  
**Higher**

US BROWNFIELDS:

**Actual:**  
**25 ft.**

Recipient name: Grant type: Property name: Property #: Parcel size: Property Description:  Latitude: Longitude: HCM label: Map scale: Point of reference: Datum: ACRES property ID: Start date: Completed date: Acres cleaned up: Cleanup funding: Cleanup funding source: Assessment funding: Assessment funding source: Redevelopment funding: Redev. funding source: Redev. funding entity name: Redevelopment start date: Assessment funding entity: Cleanup funding entity: Grant type: Accomplishment type: Accomplishment count: Cooperative agreement #: Ownership entity: Current owner: Did owner change: Cleanup required: Video available: Photo available: Institutional controls required: IC Category proprietary controls: IC cat. info. devices: IC cat. gov. controls: IC cat. enforcement permit tools: IC in place date:	Gulfport, City of Assessment FORMER BARRETT CLEANERS 0811L-01-029.000 .23 The property consists of approximately 0.23 acres in Section 9, Township 8 North, and Range 11 West. The property is identified as Parcel # 0811L-01-029.000, and is located at 2711 14th Street in Gulfport, Mississippi, latitude 30224.44 North, longitude 890543.44 West. At the time of the site reconnaissance performed on July 10, 2012, the property was improved with one 8,000-square foot vacant building. The historical use of the property as an automobile dealership/gasoline filling station and dry cleaners represents a recognized environmental condition. The property was surrounded by a railway, a vacant lot, a parking lot, and commercial properties. The property is owned by Bayou Gulf & Ventures, LLC.  30.367822 -89.09537 Address Matching-House Number Not reported Entrance Point of a Facility or Station North American Datum of 1983 150082 Not reported Not reported Not reported Not reported Not reported 5400 US EPA - Brownfields Assessment Cooperative Agreement Not reported Not reported Not reported Not reported EPA Not reported H Phase II Environmental Assessment 0 95482611 Private Bayou Gulf & Ventures, LLC N No No Yes N Not reported Not reported Not reported Not reported Not reported
--	---

Map ID  
Direction  
Distance  
Elevation

MAP FINDINGS

Site

Database(s)

EDR ID Number  
EPA ID Number

**FORMER BARRETT CLEANERS (Continued)**

**1016456723**

IC in place:	No
State/tribal program date:	Not reported
State/tribal program ID:	Not reported
State/tribal NFA date:	Not reported
Air contaminated:	Not reported
Air cleaned:	Not reported
Asbestos found:	Not reported
Asbestos cleaned:	Not reported
Controlled substance found:	Not reported
Controlled substance cleaned:	Not reported
Drinking water affected:	Not reported
Drinking water cleaned:	Not reported
Groundwater affected:	Not reported
Groundwater cleaned:	Not reported
Lead contaminant found:	Not reported
Lead cleaned up:	Not reported
No media affected:	Y
Unknown media affected:	Not reported
Other cleaned up:	Not reported
Other metals found:	Not reported
Other metals cleaned:	Not reported
Other contaminants found:	Not reported
Other contams found description:	Not reported
PAHs found:	Not reported
PAHs cleaned up:	Not reported
PCBs found:	Not reported
PCBs cleaned up:	Not reported
Petro products found:	Not reported
Petro products cleaned:	Not reported
Sediments found:	Not reported
Sediments cleaned:	Not reported
Soil affected:	Not reported
Soil cleaned up:	Not reported
Surface water cleaned:	Not reported
VOCs found:	Not reported
VOCs cleaned:	Not reported
Cleanup other description:	Not reported
Num. of cleanup and re-dev. jobs:	Not reported
Past use greenspace acreage:	Not reported
Past use residential acreage:	Not reported
Past use commercial acreage:	.23
Past use industrial acreage:	Not reported
Future use greenspace acreage:	Not reported
Future use residential acreage:	Not reported
Future use commercial acreage:	Not reported
Future use industrial acreage:	Not reported
Greenspace acreage and type:	Not reported
Superfund Fed. landowner flag:	Not reported
Arsenic cleaned up:	Not reported
Cadmium cleaned up:	Not reported
Chromium cleaned up:	Not reported
Copper cleaned up:	Not reported
Iron cleaned up:	Not reported
mercury cleaned up:	Not reported
nickel cleaned up:	Not reported
No clean up:	Not reported
Pesticides cleaned up:	Not reported

Map ID  
Direction  
Distance  
Elevation

MAP FINDINGS

Site

Database(s)

EDR ID Number  
EPA ID Number

**FORMER BARRETT CLEANERS (Continued)**

**1016456723**

Selenium cleaned up: Not reported  
SVOCs cleaned up: Not reported  
Unknown clean up: Not reported  
Arsenic contaminant found: Not reported  
Cadmium contaminant found: Not reported  
Chromium contaminant found: Not reported  
Copper contaminant found: Not reported  
Iron contaminant found: Not reported  
Mercury contaminant found: Not reported  
Nickel contaminant found: Not reported  
No contaminant found: Not reported  
Pesticides contaminant found: Not reported  
Selenium contaminant found: Not reported  
SVOCs contaminant found: Not reported  
Unknown contaminant found: Not reported  
Future Use: Multistory Not reported  
Media affected Bluiding Material: Not reported  
Media affected indoor air: Not reported  
Building material media cleaned up: Not reported  
Indoor air media cleaned up: Not reported  
Unknown media cleaned up: Not reported  
Past Use: Multistory Not reported

Recipient name: Gulfport, City of  
Grant type: Assessment  
Property name: FORMER BARRETT CLEANERS  
Property #: 0811L-01-029.000  
Parcel size: .23  
Property Description: The property consists of approximately 0.23 acres in Section 9, Township 8 North, and Range 11 West. The property is identified as Parcel # 0811L-01-029.000, and is located at 2711 14th Street in Gulfport, Mississippi, latitude 30224.44 North, longitude 890543.44 West. At the time of the site reconnaissance performed on July 10, 2012, the property was improved with one 8,000-square foot vacant building. The historical use of the property as an automobile dealership/gasoline filling station and dry cleaners represents a recognized environmental condition. The property was surrounded by a railway, a vacant lot, a parking lot, and commercial properties. The property is owned by Bayou Gulf & Ventures, LLC.

Latitude: 30.367822  
Longitude: -89.09537  
HCM label: Address Matching-House Number  
Map scale: Not reported  
Point of reference: Entrance Point of a Facility or Station  
Datum: North American Datum of 1983  
ACRES property ID: 150082  
Start date: Not reported  
Completed date: Not reported  
Acres cleaned up: Not reported  
Cleanup funding: Not reported  
Cleanup funding source: Not reported  
Assessment funding: 6870  
Assessment funding source: US EPA - Brownfields Assessment Cooperative Agreement  
Redevelopment funding: Not reported  
Redev. funding source: Not reported  
Redev. funding entity name: Not reported  
Redevelopment start date: Not reported

Map ID  
Direction  
Distance  
Elevation

MAP FINDINGS

Site

Database(s)

EDR ID Number  
EPA ID Number

**FORMER BARRETT CLEANERS (Continued)**

**1016456723**

Assessment funding entity:	EPA
Cleanup funding entity:	Not reported
Grant type:	H
Accomplishment type:	Phase I Environmental Assessment
Accomplishment count:	1
Cooperative agreement #:	95482611
Ownership entity:	Private
Current owner:	Bayou Gulf & Ventures,LLC
Did owner change:	N
Cleanup required:	No
Video available:	No
Photo available:	Yes
Institutional controls required:	N
IC Category proprietary controls:	Not reported
IC cat. info. devices:	Not reported
IC cat. gov. controls:	Not reported
IC cat. enforcement permit tools:	Not reported
IC in place date:	Not reported
IC in place:	No
State/tribal program date:	Not reported
State/tribal program ID:	Not reported
State/tribal NFA date:	Not reported
Air contaminated:	Not reported
Air cleaned:	Not reported
Asbestos found:	Not reported
Asbestos cleaned:	Not reported
Controlled substance found:	Not reported
Controlled substance cleaned:	Not reported
Drinking water affected:	Not reported
Drinking water cleaned:	Not reported
Groundwater affected:	Not reported
Groundwater cleaned:	Not reported
Lead contaminant found:	Not reported
Lead cleaned up:	Not reported
No media affected:	Y
Unknown media affected:	Not reported
Other cleaned up:	Not reported
Other metals found:	Not reported
Other metals cleaned:	Not reported
Other contaminants found:	Not reported
Other contams found description:	Not reported
PAHs found:	Not reported
PAHs cleaned up:	Not reported
PCBs found:	Not reported
PCBs cleaned up:	Not reported
Petro products found:	Not reported
Petro products cleaned:	Not reported
Sediments found:	Not reported
Sediments cleaned:	Not reported
Soil affected:	Not reported
Soil cleaned up:	Not reported
Surface water cleaned:	Not reported
VOCs found:	Not reported
VOCs cleaned:	Not reported
Cleanup other description:	Not reported
Num. of cleanup and re-dev. jobs:	Not reported
Past use greenspace acreage:	Not reported



Map ID  
 Direction  
 Distance  
 Elevation

MAP FINDINGS

Site

Database(s)

EDR ID Number  
 EPA ID Number

**FORMER BARRETT CLEANERS (Continued)**

**1016456723**

Past use residential acreage: Not reported  
 Past use commercial acreage: .23  
 Past use industrial acreage: Not reported  
 Future use greenspace acreage: Not reported  
 Future use residential acreage: Not reported  
 Future use commercial acreage: Not reported  
 Future use industrial acreage: Not reported  
 Greenspace acreage and type: Not reported  
 Superfund Fed. landowner flag: Not reported  
 Arsenic cleaned up: Not reported  
 Cadmium cleaned up: Not reported  
 Chromium cleaned up: Not reported  
 Copper cleaned up: Not reported  
 Iron cleaned up: Not reported  
 mercury cleaned up: Not reported  
 nickel cleaned up: Not reported  
 No clean up: Not reported  
 Pesticides cleaned up: Not reported  
 Selenium cleaned up: Not reported  
 SVOCs cleaned up: Not reported  
 Unknown clean up: Not reported  
 Arsenic contaminant found: Not reported  
 Cadmium contaminant found: Not reported  
 Chromium contaminant found: Not reported  
 Copper contaminant found: Not reported  
 Iron contaminant found: Not reported  
 Mercury contaminant found: Not reported  
 Nickel contaminant found: Not reported  
 No contaminant found: Not reported  
 Pesticides contaminant found: Not reported  
 Selenium contaminant found: Not reported  
 SVOCs contaminant found: Not reported  
 Unknown contaminant found: Not reported  
 Future Use: Multistory Not reported  
 Media affected Bluiding Material: Not reported  
 Media affected indoor air: Not reported  
 Building material media cleaned up: Not reported  
 Indoor air media cleaned up: Not reported  
 Unknown media cleaned up: Not reported  
 Past Use: Multistory Not reported

**J63**  
**North**  
**1/4-1/2**  
**0.270 mi.**  
**1425 ft.**

**FORMER BARRETT CLEANERS**  
**2711 14TH STREET**  
**GULFPORT, MS 39506**  
**Site 3 of 5 in cluster J**

**FINDS 1016643719**  
**N/A**

**Relative:**  
**Higher**

FINDS:

Registry ID: 110056254388

**Actual:**  
**25 ft.**

Environmental Interest/Information System  
 US EPA Assessment, Cleanup and Redevelopment Exchange System (ACRES)  
 is an federal online database for Brownfields Grantees to  
 electronically submit data directly to EPA.

MAP FINDINGS

Map ID			EDR ID Number
Direction			EPA ID Number
Distance			
Elevation	Site	Database(s)	

---

<b>J64</b> North 1/4-1/2 0.270 mi. 1425 ft.	<b>JACK BARRETTS MODERN CLEANERS</b> 2711 14TH STREET GULFPORT, MS 39501  Site 4 of 5 in cluster J	<b>FINDS</b>	<b>1016017264</b> N/A
---	--	--------------	--------------------------

**Relative:** FINDS:

**Higher** Registry ID: 110044426859

**Actual:** Environmental Interest/Information System

**25 ft.** MS-ENSITE (Mississippi - Tools For Environmental Management And Protection Organizations). Mississippi Department of Environmental Quality (MDEQ) Office of Pollution Control's (OPC) maintains enSite. It is the electronic Environmental Site Information System that that regulates compliance assurance, permitting, activity tracking, and maintenance of a single agency interest-link to definition master file.

---

<b>J65</b> North 1/4-1/2 0.270 mi. 1425 ft.	2711 14TH ST GULFPORT, MS 39501  Site 5 of 5 in cluster J	<b>EDR US Hist Cleaners</b>	<b>1015032219</b> N/A
---	--	-----------------------------	--------------------------

**Relative:** EDR Historical Cleaners:

**Higher** Name: MODERN CLEANERS AND LAUNDRY  
 Year: 1999  
 Address: 2711 14TH ST

Name: MODERN CLEANERS AND LAUNDRY  
 Year: 2000  
 Address: 2711 14TH ST

Name: MODERN CLEANERS & LAUNDRY  
 Year: 2003  
 Address: 2711 14TH ST

Name: JACK BARRETTS MODERN CLNR  
 Year: 2004  
 Address: 2711 14TH ST

Name: BARRETT JACK CLEANERS  
 Year: 2005  
 Address: 2711 14TH ST

---

<b>K66</b> North 1/4-1/2 0.271 mi. 1429 ft.	<b>MDOT HARRISON COUNTY PROJECT</b> 1401 28TH AVENUE GULFPORT, MS 39501  Site 1 of 2 in cluster K	<b>ASBESTOS</b>	<b>S113746309</b> N/A
---	---	-----------------	--------------------------

**Relative:** ASBESTOS:

**Higher** AI ID: 38685  
 SR No: Not reported

**Actual:** City: GULFPORT

**26 ft.** County: Harrison

Map ID  
Direction  
Distance  
Elevation

MAP FINDINGS

Site

Database(s)

EDR ID Number  
EPA ID Number

**MDOT HARRISON COUNTY PROJECT (Continued)**

**S113746309**

ACT Type: Demolition  
Branch: Air Demolition and Renovation  
SIC: NONE SELECTED  
Basin: None  
Start Date: 06/10/2013  
Start Date 1: 10/02/2008  
Date End: Not reported  
Mailing Address: PO Box 15925 Hattiesburg, MS 39401  
Office of Pollution Control Name: Not reported  
Office of Pollution Control Assignment: Not reported  
Office of Pollution Control Phone: Not reported

**K67**  
**North**  
**1/4-1/2**  
**0.278 mi.**  
**1470 ft.**

**MDOT - LAZANA PROPERTY/MASTER BRAKE SERVICE**  
**GULFPORT, MS**

**SHWS S108634347**  
**N/A**

**Site 2 of 2 in cluster K**

**Relative:**  
**Higher**

SHWS:  
Lat/Long (dms): 30 22 6 / 89 5 46  
Site Size (acres): Not reported  
EPA ID: Not reported  
Project Manager: Not reported  
**Status: SNFA**  
State No Further Action Date: 07/19/2001  
Federal: Not reported  
Federal No Further Action Date: Not reported  
Soil Contamination: No  
Surface Water Contamination: No  
Ground Water Contamination: No  
Remediation Type: Not reported  
Surface Water Remediation: Not reported  
GW Remediation Type: Not reported  
Maj. Contaminant: Not reported  
High Concentration: Not reported  
High Concentration Units: Not reported  
Institutional Control: Not reported  
Engineering Control: Not reported  
Voluntary Cleanups: Not reported

**Actual:**  
**26 ft.**

**L68**  
**NE**  
**1/4-1/2**  
**0.279 mi.**  
**1472 ft.**

**WHITNEY NATIONAL BANK**  
**1300 25TH AVENUE**  
**GULFPORT, MS 39501**  
**Site 1 of 12 in cluster L**

**UST U004053272**  
**N/A**

**Relative:**  
**Higher**

UST:  
Facility ID: 12714  
Facility Status: Inactive  
Latitude: 30 22' 2.0000"  
Longitude: 89 5' 34.0000"  
Permanently Out of Use Tanks: 1  
Active Tanks: 0  
AIID: 36136  
Owner Name: Whitney National Bank  
Owner Address: 1300 25th Avenue

**Actual:**  
**20 ft.**

Map ID  
Direction  
Distance  
Elevation

MAP FINDINGS

Site

Database(s)

EDR ID Number  
EPA ID Number

**WHITNEY NATIONAL BANK (Continued)**

**U004053272**

Owner Tele: (228)864-7332

Tank:  
Tank No: 1  
Tank ID: 31069  
**Tank Status: Permanently Out of Use**  
Tank Capacity: 750  
Date Installed: 01/01/1974  
Substance: Diesel  
Reported Release: Not reported  
Close Type: Not reported  
Date Removed: 05/06/2006  
Close Type: 05/06/2006  
Tank Material: Unknown  
2nd Containmnt: Not reported  
Tank Lead Detection: Not reported  
Overfill Protection: No  
Spill Prevention: No

Pipe:  
Tank No: 1  
Tank Id: 31069  
Pipe Id: 1  
Pipe Status: Permanently Out of Use  
Type Of Closure: Not reported  
Pipe Material Construction: Unknown  
Secondary Pipe Material: None  
Piping Type: Not reported  
Pipe Leak Detection: Not reported

**L69  
NE  
1/4-1/2  
0.280 mi.  
1481 ft.**

**FIRESTONE STORE #0503  
1420 25TH AVENUE  
GULFPORT, MS  
Site 2 of 12 in cluster L**

**RGA LUST S116269996  
N/A**

**Relative:  
Higher**

RGA LUST:

**Actual:  
20 ft.**

2012	FIRESTONE STORE #0503	1420 25TH AVENUE
2011	FIRESTONE STORE #0503	1420 25TH AVENUE
2010	FIRESTONE STORE #0503	1420 25TH AVENUE
2009	FIRESTONE STORE #0503	1420 25TH AVENUE
2008	FIRESTONE STORE #0503	1420 25TH AVENUE
2007	FIRESTONE STORE #0503	1420 25TH AVENUE
2006	FIRESTONE STORE #0503	1420 25TH AVENUE
2005	FIRESTONE STORE #0503	1420 25TH AVENUE
2004	FIRESTONE STORE #0503	1420 25TH AVENUE
2003	FIRESTONE STORE #0503	1420 25TH AVENUE
2002	FIRESTONE STORE #0503	1420 25TH AVENUE
2001	FIRESTONE STORE #0503	1420 25TH AVENUE
2000	FIRESTONE STORE #0503	1420 25TH AVENUE
1999	FIRESTONE STORE #0503	1420 25TH AVENUE
1998	FIRESTONE STORE #0503	1420 25TH AVENUE
1997	FIRESTONE STORE #0503	1420 25TH AVENUE
1996	FIRESTONE STORE #0503	1420 25TH AVENUE

MAP FINDINGS

Map ID			EDR ID Number
Direction			EPA ID Number
Distance			
Elevation	Site	Database(s)	

---

<b>L70</b>	<b>FIRESTONE</b>	<b>FINDS</b>	<b>1016621851</b>
<b>NE</b>	<b>1420 25TH AVENUE</b>		<b>N/A</b>
<b>1/4-1/2</b>	<b>GULFPORT, MS 39501</b>		
<b>0.280 mi.</b>			
<b>1481 ft.</b>	<b>Site 3 of 12 in cluster L</b>		

**Relative:**  
**Higher**

**FINDS:**

Registry ID: 110002221471

**Actual:**  
**20 ft.**

Environmental Interest/Information System

RCRAInfo is a national information system that supports the Resource Conservation and Recovery Act (RCRA) program through the tracking of events and activities related to facilities that generate, transport, and treat, store, or dispose of hazardous waste. RCRAInfo allows RCRA program staff to track the notification, permit, compliance, and corrective action activities required under RCRA.

MS-ENSITE (Mississippi - Tools For Environmental Management And Protection Organizations). Mississippi Department of Environmental Quality (MDEQ) Office of Pollution Control's (OPC) maintains enSite. It is the electronic Environmental Site Information System that regulates compliance assurance, permitting, activity tracking, and maintenance of a single agency interest-link to definition master file.

<b>L71</b>	<b>FIRESTONE STORE #0503</b>	<b>LUST</b>	<b>1000475981</b>
<b>NE</b>	<b>1420 25TH AVENUE</b>	<b>UST</b>	<b>N/A</b>
<b>1/4-1/2</b>	<b>GULFPORT, MS 39501</b>		
<b>0.280 mi.</b>			
<b>1481 ft.</b>	<b>Site 4 of 12 in cluster L</b>		

**Relative:**  
**Higher**

Facility Id: 2008  
 Facility Status: Inactive  
 Lust Status: Closed  
 AIID: 4930  
 Event #: 1  
 Project Manager: Larry Flynt  
 Date Of Report: 06/01/1994  
 Trust Fund Status: NTFE  
 Confirmed On: 06/01/1994  
 NFA Date: 09/27/1994

**Actual:**  
**20 ft.**

**UST:**

Facility ID: 2008  
 Facility Status: Inactive  
 Latitude: 30 22' 14.0000"  
 Longitude: 89 5' 57.0000"  
 Permanently Out of Use Tanks: 1  
 Active Tanks: 0  
 AIID: 4930  
 Owner Name: Not reported  
 Owner Address: Not reported  
 Owner Tele: Not reported

**Tank:**

Tank No: 1

Map ID  
Direction  
Distance  
Elevation

MAP FINDINGS

Site

Database(s)

EDR ID Number  
EPA ID Number

**FIRESTONE STORE #0503 (Continued)**

1000475981

Tank ID: 4564  
**Tank Status:** Permanently Out of Use  
Tank Capacity: 550  
Date Installed: 01/01/1983  
Substance: Used Oil  
Reported Release: Yes  
Close Type: Closed  
Date Removed: 12/31/1988  
Close Type: 05/03/1994  
Tank Material: Asphalt Coated or Bare Steel  
2nd Containmnt: None  
Tank Lead Detection: N/A  
Overfill Protection: No  
Spill Prevention: No

L72  
NE  
1/4-1/2  
0.280 mi.  
1481 ft.

**FIRESTONE STORES**  
**1420 25TH AVENUE**  
**GULFPORT, MS 39501**

RCRA-CESQG

1004743002  
MSD982772360

Site 5 of 12 in cluster L

Relative:  
Higher

RCRA-CESQG:

Date form received by agency: 03/07/1990  
Facility name: FIRESTONE STORES  
Facility address: 1420 25TH AVENUE  
GULFPORT, MS 39501  
EPA ID: MSD982772360  
Mailing address: 25TH AVENUE  
GULFPORT, MS 39501  
Contact: ANDY BROWN  
Contact address: 1420 25TH AVENUE  
GULFPORT, MS 39501  
Contact country: US  
Contact telephone: (601) 863-1091  
Contact email: Not reported  
EPA Region: 04  
Classification: Conditionally Exempt Small Quantity Generator  
Description: Handler: generates 100 kg or less of hazardous waste per calendar month, and accumulates 1000 kg or less of hazardous waste at any time; or generates 1 kg or less of acutely hazardous waste per calendar month, and accumulates at any time: 1 kg or less of acutely hazardous waste; or 100 kg or less of any residue or contaminated soil, waste or other debris resulting from the cleanup of a spill, into or on any land or water, of acutely hazardous waste; or generates 100 kg or less of any residue or contaminated soil, waste or other debris resulting from the cleanup of a spill, into or on any land or water, of acutely hazardous waste during any calendar month, and accumulates at any time: 1 kg or less of acutely hazardous waste; or 100 kg or less of any residue or contaminated soil, waste or other debris resulting from the cleanup of a spill, into or on any land or water, of acutely hazardous waste

Actual:  
20 ft.

Owner/Operator Summary:

Owner/operator name: FIRESTONE  
Owner/operator address: Not reported  
Not reported  
Owner/operator country: Not reported

Map ID  
Direction  
Distance  
Elevation

MAP FINDINGS

Site

Database(s)

EDR ID Number  
EPA ID Number

**FIRESTONE STORES (Continued)**

**1004743002**

Owner/operator telephone: Not reported  
Legal status: Private  
Owner/Operator Type: Owner  
Owner/Op start date: Not reported  
Owner/Op end date: Not reported

Handler Activities Summary:

U.S. importer of hazardous waste: No  
Mixed waste (haz. and radioactive): No  
Recycler of hazardous waste: No  
Transporter of hazardous waste: No  
Treater, storer or disposer of HW: No  
Underground injection activity: No  
On-site burner exemption: No  
Furnace exemption: No  
Used oil fuel burner: No  
Used oil processor: No  
User oil refiner: No  
Used oil fuel marketer to burner: No  
Used oil Specification marketer: No  
Used oil transfer facility: No  
Used oil transporter: No

. Waste code: D001  
. Waste name: IGNITABLE WASTE

. Waste code: F001  
. Waste name: THE FOLLOWING SPENT HALOGENATED SOLVENTS USED IN DEGREASING: TETRACHLOROETHYLENE, TRICHLORETHYLENE, METHYLENE CHLORIDE, 1,1,1-TRICHLOROETHANE, CARBON TETRACHLORIDE AND CHLORINATED FLUOROCARBONS; ALL SPENT SOLVENT MIXTURES/BLENDS USED IN DEGREASING CONTAINING, BEFORE USE, A TOTAL OF TEN PERCENT OR MORE (BY VOLUME) OF ONE OR MORE OF THE ABOVE HALOGENATED SOLVENTS OR THOSE SOLVENTS LISTED IN F002, F004, AND F005; AND STILL BOTTOMS FROM THE RECOVERY OF THESE SPENT SOLVENTS AND SPENT SOLVENT MIXTURES.

Violation Status: No violations found

L73  
NE  
1/4-1/2  
0.280 mi.  
1481 ft.

1420 25TH AVE  
GULFPORT, MS 39501  
Site 6 of 12 in cluster L

EDR US Hist Auto Stat 1015225236  
N/A

Relative:  
Higher

EDR Historical Auto Stations:

Name: FIRESTONE TIRE & SERVICE CTR  
Year: 2004  
Address: 1420 25TH AVE

Actual:  
20 ft.

MAP FINDINGS

Map ID	Direction	Distance	Elevation	Site	Database(s)	EDR ID Number	EPA ID Number
M74	ESE	1/4-1/2	0.281 mi.	901 23RD AVENUE GULFPORT, MS	ERNS	2005606633	N/A
			1486 ft.	Site 1 of 3 in cluster M			
Relative: Lower				<a href="#">Click this hyperlink</a> while viewing on your computer to access additional ERNS detail in the EDR Site Report.			
Actual: 7 ft.				-----			
N75	WSW	1/4-1/2	0.283 mi.	3215 WEST BEACH BLVD GULFPORT, MS 39501	ERNS	2005600492	N/A
			1496 ft.	Site 1 of 8 in cluster N			
Relative: Higher				<a href="#">Click this hyperlink</a> while viewing on your computer to access additional ERNS detail in the EDR Site Report.			
Actual: 10 ft.				-----			
N76	WSW	1/4-1/2	0.283 mi.	3215 WEST BEACH BLVD. GULFPORT, MS 39501	ERNS	2004734556	N/A
			1496 ft.	Site 2 of 8 in cluster N			
Relative: Higher				<a href="#">Click this hyperlink</a> while viewing on your computer to access additional ERNS detail in the EDR Site Report.			
Actual: 10 ft.				-----			
N77	WSW	1/4-1/2	0.283 mi.	3215 WEST BEACH BLVD GULF PORT, MS	ERNS	2005600682	N/A
			1496 ft.	Site 3 of 8 in cluster N			
Relative: Higher				<a href="#">Click this hyperlink</a> while viewing on your computer to access additional ERNS detail in the EDR Site Report.			
Actual: 10 ft.				-----			
N78	WSW	1/4-1/2	0.283 mi.	3215 WEST BEACH BLVD GULFPORT, MS	ERNS	2005602640	N/A
			1496 ft.	Site 4 of 8 in cluster N			
Relative: Higher				<a href="#">Click this hyperlink</a> while viewing on your computer to access additional ERNS detail in the EDR Site Report.			
Actual: 10 ft.				-----			
N79	WSW	1/4-1/2	0.283 mi.	3215 WEST BEACH BLVD GULFPORT, MS 39501	ERNS	2001557786	N/A
			1496 ft.	Site 5 of 8 in cluster N			
Relative: Higher				<a href="#">Click this hyperlink</a> while viewing on your computer to access additional ERNS detail in the EDR Site Report.			
Actual: 10 ft.				-----			



MAP FINDINGS

Map ID			EDR ID Number
Direction			EPA ID Number
Distance			
Elevation	Site	Database(s)	

---

<b>N80</b> <b>WSW</b> <b>1/4-1/2</b> <b>0.283 mi.</b> <b>1496 ft.</b>	<b>3215 WEST BEACH BLVD.</b> <b>GULFPORT, MS 0</b>  <b>Site 6 of 8 in cluster N</b>	<b>ERNS</b>	<b>2000533723</b> <b>N/A</b>
---	--	-------------	---------------------------------

**Relative:** [Click this hyperlink](#) while viewing on your computer to access additional ERNS detail in the EDR Site Report.

**Higher**

<b>Actual:</b> <b>10 ft.</b> <b>81</b> <b>NE</b> <b>1/4-1/2</b> <b>0.291 mi.</b> <b>1539 ft.</b>	<b>ARIZONA CHEMICAL</b>  <b>GULFPORT, MS</b>	<b>SHWS</b>	<b>S102256736</b> <b>N/A</b>
--	--	-------------	---------------------------------

**Relative:** SHWS:

Lat/Long (dms):	30 22 0 / 89 5 30
Site Size (acres):	Not reported
EPA ID:	MSD001661719
Project Manager:	Not reported
<b>Status:</b>	<b>Not reported</b>
State No Further Action Date:	Not reported
Federal:	Archive
Federal No Further Action Date:	02/25/1998
Soil Contamination:	No
Surface Water Contamination:	No
Ground Water Contamination:	No
Remediation Type:	Not reported
Surface Water Remediation:	Not reported
GW Remediation Type:	Not reported
Maj. Contaminant:	No DATA
High Concentration:	Not reported
High Concentration Units:	Not reported
Institutional Control:	Not reported
Engineering Control:	Not reported
Voluntary Cleanups:	Not reported

<b>N82</b> <b>WSW</b> <b>1/4-1/2</b> <b>0.293 mi.</b> <b>1546 ft.</b>	<b>BEHIND THE GRAND CASINO</b> <b>GULFPORT, MS</b>  <b>Site 7 of 8 in cluster N</b>	<b>ERNS</b>	<b>99639835</b> <b>N/A</b>
---	--	-------------	-------------------------------

**Relative:** [Click this hyperlink](#) while viewing on your computer to access additional ERNS detail in the EDR Site Report.

**Higher**

<b>Actual:</b> <b>16 ft.</b> <b>N83</b> <b>WSW</b> <b>1/4-1/2</b> <b>0.293 mi.</b> <b>1546 ft.</b>	<b>COMMERCIAL SHRIMP HARBOR BEHIND THE GRANDE CASINO</b> <b>GULFPORT, MS</b>  <b>Site 8 of 8 in cluster N</b>	<b>ERNS</b>	<b>96506565</b> <b>N/A</b>
--	--	-------------	-------------------------------

**Relative:** [Click this hyperlink](#) while viewing on your computer to access additional ERNS detail in the EDR Site Report.

**Higher**

**Actual:**  
16 ft.

MAP FINDINGS

Map ID  
Direction  
Distance  
Elevation

Site

Database(s)

EDR ID Number  
EPA ID Number

**O84**  
**NNW**  
**1/4-1/2**  
**0.310 mi.**  
**1636 ft.**

**BAY ICE COMPANY, INC.**  
**1413 30TH AVENUE**  
**GULFPORT, MS 39501**  
**Site 1 of 3 in cluster O**

**ICIS 1011539559**  
**FINDS N/A**

**Relative:**  
**Higher**

ICIS:  
Enforcement Action ID: 04-1998-0025  
FRS ID: 110010587169  
Program ID: FRS 110010587169  
Action Name: BAY ICE COMPANY, INC.  
Full Address: 1413 30TH AVENUE GULFPORT MS 39501-2737  
State: Mississippi  
Facility Name: BAY ICE COMPANY, INC.  
Facility Address: 1413 30TH AVENUE  
GULFPORT, MS 39501-2737  
Enforcement Action Type: EPCRA 325 Action For Penalty  
Facility County: HARRISON  
EPA Region #: 4

**Actual:**  
**24 ft.**

Program ID: FRS 110010587169  
Facility Name: BAY ICE COMPANY, INC.  
Address: 1413 30TH AVENUE  
Tribal Indicator: N  
Fed Facility: Not reported  
NAIC Code: Not reported  
SIC Code: 2097

**FINDS:**

Registry ID: 110010587169

**Environmental Interest/Information System**

ICIS (Integrated Compliance Information System) is the Integrated Compliance Information System and provides a database that, when complete, will contain integrated Enforcement and Compliance information across most of EPA's programs. The vision for ICIS is to replace EPA's independent databases that contain Enforcement data with a single repository for that information. Currently, ICIS contains all Federal Administrative and Judicial enforcement actions. This information is maintained in ICIS by EPA in the Regional offices and it Headquarters. A future release of ICIS will replace the Permit Compliance System (PCS) which supports the NPDES and will integrate that information with Federal actions already in the system. ICIS also has the capability to track other activities occurring in the Region that support Compliance and Enforcement programs. These include; Incident Tracking, Compliance Assistance, and Compliance Monitoring.

Map ID  
Direction  
Distance  
Elevation

MAP FINDINGS

Site

Database(s)

EDR ID Number  
EPA ID Number

**L85**      **HANCOCK BANK**  
**NNE**      **2510 14TH STREET**  
**1/4-1/2**    **GULFPORT, MS 39501**  
**0.314 mi.**  
**1658 ft.**    **Site 7 of 12 in cluster L**

**ASBESTOS**    **S117405502**  
                         **N/A**

**Relative:**  
**Higher**

ASBESTOS:

AI ID:            26149  
SR No:           133  
City:             GULFPORT  
County:          Harrison  
ACT Type:       Renovation  
Branch:          UST  
SIC:              5541  
Basin:            None  
Start Date:      11/16/2014  
Start Date 1:    07/27/1998  
Date End:        01/01/1900  
Mailing Address: PO BOX 4019 GULFPORT, MS 39502  
Office of Pollution Control Name:    Henderson, Kevin  
Office of Pollution Control Assignment: Office of Pollution Control Compliance Manager  
Office of Pollution Control Phone:    (601) 961-5283

**Actual:**  
**23 ft.**

AI ID:            26149  
SR No:           138  
City:             GULFPORT  
County:          Harrison  
ACT Type:       Renovation  
Branch:          UST  
SIC:              5541  
Basin:            None  
Start Date:      11/16/2014  
Start Date 1:    07/27/1998  
Date End:        01/01/1900  
Mailing Address: PO BOX 4019 GULFPORT, MS 39502  
Office of Pollution Control Name:    Henderson, Kevin  
Office of Pollution Control Assignment: Office of Pollution Control Compliance Manager  
Office of Pollution Control Phone:    (601) 961-5283

**L86**  
**NNE**      **2510 14TH ST**  
**1/4-1/2**    **GULFPORT, MS 39501**  
**0.314 mi.**  
**1658 ft.**    **Site 8 of 12 in cluster L**

**EDR US Hist Cleaners**    **1015028247**  
   **N/A**

**Relative:**  
**Higher**

EDR Historical Cleaners:

Name:            CLEANER IMAGE CLEANERS  
Year:             2011  
Address:          2510 14TH ST

**Actual:**  
**23 ft.**

Name:            CLEANER IMAGE CLEANERS  
Year:             2012  
Address:          2510 14TH ST

MAP FINDINGS

Map ID  
 Direction  
 Distance  
 Elevation

Site

Database(s)

EDR ID Number  
 EPA ID Number

**L87**      **HANCOCK BANK**  
**NNE**      **2510 14TH STREET**  
**1/4-1/2**    **GULFPORT, MS 39501**  
**0.314 mi.**  
**1658 ft.**    **Site 9 of 12 in cluster L**

**UST**    **U003775325**  
           **N/A**

**Relative:**  
**Higher**

UST:  
 Facility ID:                    12057  
 Facility Status:                Active  
 Latitude:                      30 22' 9.0000"  
 Longitude:                     89 5' 36.8000"  
 Permanently Out of Use Tanks: 1  
 Active Tanks:                 1  
 AIID:                          26149  
 Owner Name:                  Hancock Bank  
 Owner Address:                PO Box 4019  
 Owner Tele:                    (228)868-4465

**Actual:**  
**23 ft.**

Tank:  
 Tank No:                        1  
 Tank ID:                        30169  
**Tank Status:                    Permanently Out of Use**  
 Tank Capacity:                500  
 Date Installed:                01/01/1983  
 Substance:                     Diesel  
 Reported Release:             Not reported  
 Close Type:                    Closed  
 Date Removed:                10/21/1998  
 Close Type:                    10/22/1998  
 Tank Material:                Asphalt Coated or Bare Steel  
 2nd Containmnt:               None  
 Tank Lead Detection:         N/A  
 Overfill Protection:         No  
 Spill Prevention:             No

Pipe:  
 Tank No:                        1  
 Tank Id:                        30169  
 Pipe Id:                         1  
 Pipe Status:                    Permanently Out of Use  
 Type Of Closure:              Closed  
 Pipe Material Construction:  Bare/Galvanized Steel  
 Secondary Pipe Material:    None  
 Piping Type:                   N/A  
 Pipe Leak Detection:         Not Listed

Tank:  
 Tank No:                        2  
 Tank ID:                        30170  
**Tank Status:                    Currently In Use**  
 Tank Capacity:                2000  
 Date Installed:                10/24/1998  
 Substance:                     Diesel  
 Reported Release:             Not reported  
 Close Type:                    Not reported  
 Date Removed:                Not reported  
 Close Type:                    Not reported

Map ID  
 Direction  
 Distance  
 Elevation

MAP FINDINGS

Site

Database(s)

EDR ID Number  
 EPA ID Number

**HANCOCK BANK (Continued)**

**U003775325**

Tank Material: Composite (Steel w/ FRP)  
 2nd Containmnt: None  
 Tank Lead Detection: Deferred  
 Overfill Protection: Yes  
 Spill Prevention: Yes

Pipe:

Tank No: 2  
 Tank Id: 30170  
 Pipe Id: 2  
 Pipe Status: Currently In Use  
 Type Of Closure: Not reported  
 Pipe Material Construction: Coated/Wrapped Steel  
 Secondary Pipe Material: Cathodically Protected  
 Piping Type: U.S. Suction  
 Pipe Leak Detection: Deferred

**L88**  
**NNE**  
 1/4-1/2  
 0.314 mi.  
 1658 ft.

**HANCOCK BANK**  
**2510 14TH STREET**  
**GULFPORT, MS 39501**  
**Site 10 of 12 in cluster L**

**FINDS 1016025361**  
**N/A**

**Relative:**  
**Higher**

**FINDS:**

Registry ID: 110044686658

**Actual:**  
**23 ft.**

Environmental Interest/Information System  
 MS-ENSITE (Mississippi - Tools For Environmental Management And Protection Organizations). Mississippi Department of Environmental Quality (MDEQ) Office of Pollution Control's (OPC) maintains enSite. It is the electronic Environmental Site Information System that that regulates compliance assurance, permitting, activity tracking, and maintenance of a single agency interest-link to definition master file.

**L89**  
**NNE**  
 1/4-1/2  
 0.315 mi.  
 1665 ft.

**2501 14TH ST**  
**GULFPORT, MS 39501**  
**Site 11 of 12 in cluster L**

**EDR US Hist Cleaners 1015027923**  
**N/A**

**Relative:**  
**Higher**

**EDR Historical Cleaners:**

Name: GULF COAST CLEANERS  
 Year: 2010  
 Address: 2501 14TH ST

**Actual:**  
**23 ft.**

MAP FINDINGS

Map ID			EDR ID Number
Direction			EPA ID Number
Distance			
Elevation	Site	Database(s)	

---

<b>L90</b> <b>NNE</b> <b>1/4-1/2</b> <b>0.317 mi.</b> <b>1673 ft.</b>	<b>2500 14TH STREET</b> <b>2500 14TH STREET</b> <b>GULFPORT, MS 39501</b>  <b>Site 12 of 12 in cluster L</b>	<b>FINDS</b>	<b>1016018863</b> <b>N/A</b>
---	--	--------------	---------------------------------

<b>Relative:</b> <b>Higher</b>	<b>FINDS:</b>  Registry ID: 110044508501  Environmental Interest/Information System MS-ENSITE (Mississippi - Tools For Environmental Management And Protection Organizations). Mississippi Department of Environmental Quality (MDEQ) Office of Pollution Control's (OPC) maintains enSite. It is the electronic Environmental Site Information System that that regulates compliance assurance, permitting, activity tracking, and maintenance of a single agency interest-link to definition master file.		
<b>Actual:</b> <b>23 ft.</b>			

<b>M91</b> <b>ESE</b> <b>1/4-1/2</b> <b>0.321 mi.</b> <b>1695 ft.</b>	<b>890 23RD AVE, JONES PARK HWY 90</b> <b>GULFPORT, MS 39501</b>  <b>Site 2 of 3 in cluster M</b>	<b>ERNS</b>	<b>2005602594</b> <b>N/A</b>
---	--	-------------	---------------------------------

<b>Relative:</b> <b>Lower</b>	<a href="#">Click this hyperlink</a> while viewing on your computer to access additional ERNS detail in the EDR Site Report.
----------------------------------	--

<b>Actual:</b> <b>7 ft.</b> <b>M92</b> <b>ESE</b> <b>1/4-1/2</b> <b>0.322 mi.</b> <b>1698 ft.</b>	<b>MISCO MARINE-LADY LUCK CASINO SITE</b>  <b>GULFPORT, MS</b>  <b>Site 3 of 3 in cluster M</b>	<b>SHWS</b>	<b>S106593162</b> <b>N/A</b>
---	---	-------------	---------------------------------

<b>Relative:</b> <b>Lower</b>	<b>SHWS:</b> Lat/Long (dms): 30 21 43 / 89 5 28 Site Size (acres): 2 EPA ID: Not reported Project Manager: Not reported <b>Status:</b> <b>SNFA</b> State No Further Action Date: 07/02/1998 Federal: Not reported Federal No Further Action Date: Not reported Soil Contamination: Yes Surface Water Contamination: No Ground Water Contamination: Yes Remediation Type: E Surface Water Remediation: Not reported GW Remediation Type: NA Maj. Contaminant: Arsenic High Concentration: 1.50E+00 High Concentration Units: mg/kg Institutional Control: Not reported Engineering Control: Not reported Voluntary Cleanups: Not reported
<b>Actual:</b> <b>7 ft.</b>	

MAP FINDINGS

Map ID Direction Distance Elevation	Site	Database(s)	EDR ID Number EPA ID Number
<b>P93</b> East 1/4-1/2 0.343 mi. 1812 ft.	<b>991 23RD AVE GULF PORT, MS 39502</b>  Site 1 of 15 in cluster P	<b>ERNS</b>	<b>2014094727 N/A</b>
<b>Relative: Lower</b>	<a href="#">Click this hyperlink</a> while viewing on your computer to access additional ERNS detail in the EDR Site Report.		
<b>Actual: 6 ft. P94</b> East 1/4-1/2 0.343 mi. 1812 ft.	<b>991 23RD AVE. GULFPORT, MS 39501</b>  Site 2 of 15 in cluster P	<b>ERNS</b>	<b>2015105540 N/A</b>
<b>Relative: Lower</b>	<a href="#">Click this hyperlink</a> while viewing on your computer to access additional ERNS detail in the EDR Site Report.		
<b>Actual: 6 ft. P95</b> East 1/4-1/2 0.343 mi. 1812 ft.	<b>991 23RD AVE GULF PORT, MS 39502</b>  Site 3 of 15 in cluster P	<b>ERNS</b>	<b>2013049453 N/A</b>
<b>Relative: Lower</b>	<a href="#">Click this hyperlink</a> while viewing on your computer to access additional ERNS detail in the EDR Site Report.		
<b>Actual: 6 ft. P96</b> East 1/4-1/2 0.343 mi. 1812 ft.	<b>991 23RD AVE GULF PORT, MS 39502</b>  Site 4 of 15 in cluster P	<b>ERNS</b>	<b>2014077232 N/A</b>
<b>Relative: Lower</b>	<a href="#">Click this hyperlink</a> while viewing on your computer to access additional ERNS detail in the EDR Site Report.		
<b>Actual: 6 ft. P97</b> East 1/4-1/2 0.343 mi. 1812 ft.	<b>US COAST GUARD STATION GULFPORT 991 23RD AVENUE GULFPORT, MS 39501</b>  Site 5 of 15 in cluster P	<b>RCRA-CESQG</b>	<b>1005416862 MS2690320427</b>
<b>Relative: Lower</b>	RCRA-CESQG: Date form received by agency: 01/11/2013 Facility name: US COAST GUARD STATION GULFPORT Facility address: 991 23RD AVENUE GULFPORT, MS 39501 EPA ID: MS2690320427 Contact: RANDALL M ANDERSON Contact address: 991 23RD AVENUE GULFPORT, MS 39501 Contact country: US Contact telephone: (228) 868-3743 Contact email: RANDALL.M.ANDERSON@USCG.MIL EPA Region: 04 Land type: Federal Classification: Conditionally Exempt Small Quantity Generator		

Map ID  
Direction  
Distance  
Elevation

MAP FINDINGS

Site

Database(s)

EDR ID Number  
EPA ID Number

**US COAST GUARD STATION GULFPORT (Continued)**

**1005416862**

Description: Handler: generates 100 kg or less of hazardous waste per calendar month, and accumulates 1000 kg or less of hazardous waste at any time; or generates 1 kg or less of acutely hazardous waste per calendar month, and accumulates at any time: 1 kg or less of acutely hazardous waste; or 100 kg or less of any residue or contaminated soil, waste or other debris resulting from the cleanup of a spill, into or on any land or water, of acutely hazardous waste; or generates 100 kg or less of any residue or contaminated soil, waste or other debris resulting from the cleanup of a spill, into or on any land or water, of acutely hazardous waste during any calendar month, and accumulates at any time: 1 kg or less of acutely hazardous waste; or 100 kg or less of any residue or contaminated soil, waste or other debris resulting from the cleanup of a spill, into or on any land or water, of acutely hazardous waste

Owner/Operator Summary:

Owner/operator name: US COAST GUARD  
Owner/operator address: 1500 15TH STREET  
MOBILE, AL 36615  
Owner/operator country: US  
Owner/operator telephone: (251) 441-6459  
Legal status: Private  
Owner/Operator Type: Owner  
Owner/Op start date: 01/11/2013  
Owner/Op end date: Not reported

Owner/operator name: JAMES OTT  
Owner/operator address: 1500 15TH STREET  
MOBILE, AL 36615  
Owner/operator country: US  
Owner/operator telephone: (251) 441-6459  
Legal status: Private  
Owner/Operator Type: Operator  
Owner/Op start date: 01/11/2013  
Owner/Op end date: Not reported

Handler Activities Summary:

U.S. importer of hazardous waste: No  
Mixed waste (haz. and radioactive): No  
Recycler of hazardous waste: No  
Transporter of hazardous waste: No  
Treater, storer or disposer of HW: No  
Underground injection activity: No  
On-site burner exemption: No  
Furnace exemption: No  
Used oil fuel burner: No  
Used oil processor: No  
Used oil refiner: No  
Used oil fuel marketer to burner: No  
Used oil Specification marketer: No  
Used oil transfer facility: No  
Used oil transporter: No

. Waste code: D001  
. Waste name: IGNITABLE WASTE



Map ID  
Direction  
Distance  
Elevation

MAP FINDINGS

Site

Database(s)

EDR ID Number  
EPA ID Number

**US COAST GUARD STATION GULFPORT (Continued)**

**1005416862**

Historical Generators:

Date form received by agency: 02/17/1992  
Site name: US COAST GUARD  
Classification: Conditionally Exempt Small Quantity Generator  
  
. Waste code: D001  
. Waste name: IGNITABLE WASTE  
  
Violation Status: No violations found

Evaluation Action Summary:

Evaluation date: 03/16/2004  
Evaluation: COMPLIANCE EVALUATION INSPECTION ON-SITE  
Area of violation: Not reported  
Date achieved compliance: Not reported  
Evaluation lead agency: State

**P98**  
East  
1/4-1/2  
0.343 mi.  
1812 ft.

**991 23RD AVE**  
**GULFPORT, MS 39502**  
  
**Site 6 of 15 in cluster P**

**ERNS 2008875509**  
**N/A**

Relative:  
Lower

[Click this hyperlink](#) while viewing on your computer to access additional ERNS detail in the EDR Site Report.

**Actual:**  
**6 ft.**  
**P99**  
East  
1/4-1/2  
0.343 mi.  
1812 ft.

**991 23RD AVE**  
**GULFPORT, MS 39502**  
  
**Site 7 of 15 in cluster P**

**ERNS 2011989750**  
**N/A**

Relative:  
Lower

[Click this hyperlink](#) while viewing on your computer to access additional ERNS detail in the EDR Site Report.

**Actual:**  
**6 ft.**  
**P100**  
East  
1/4-1/2  
0.343 mi.  
1812 ft.

**991 23RD AVE**  
**GULFPORT, MS 39502**  
  
**Site 8 of 15 in cluster P**

**ERNS 2008877978**  
**N/A**

Relative:  
Lower

[Click this hyperlink](#) while viewing on your computer to access additional ERNS detail in the EDR Site Report.

**Actual:**  
**6 ft.**  
**P101**  
East  
1/4-1/2  
0.343 mi.  
1812 ft.

**991 23RD AVE.**  
**GULFPORT, MS 39501**  
  
**Site 9 of 15 in cluster P**

**ERNS 2009910874**  
**N/A**

Relative:  
Lower

[Click this hyperlink](#) while viewing on your computer to access additional ERNS detail in the EDR Site Report.

**Actual:**  
**6 ft.**

MAP FINDINGS

Map ID	Direction	Distance	Elevation	Site	Database(s)	EDR ID Number	EPA ID Number	
P102	East	1/4-1/2	0.343 mi. 1812 ft.	991 23RD AVE GULF PORT, MS 39502 Site 10 of 15 in cluster P	ERNS	2014077569	N/A	
Relative: Lower				<a href="#">Click this hyperlink</a> while viewing on your computer to access additional ERNS detail in the EDR Site Report.				
Actual: 6 ft.	-----							
P103	East	1/4-1/2	0.343 mi. 1812 ft.	991 23RD AVE GULF PORT, MS 39501 Site 11 of 15 in cluster P	ERNS	2012032262	N/A	
Relative: Lower				<a href="#">Click this hyperlink</a> while viewing on your computer to access additional ERNS detail in the EDR Site Report.				
Actual: 6 ft.	-----							
P104	East	1/4-1/2	0.343 mi. 1812 ft.	991 23RD AVE. GULFPORT, MS 39501 Site 12 of 15 in cluster P	ERNS	2008910874	N/A	
Relative: Lower				<a href="#">Click this hyperlink</a> while viewing on your computer to access additional ERNS detail in the EDR Site Report.				
Actual: 6 ft.	-----							
P105	East	1/4-1/2	0.343 mi. 1812 ft.	991 23RD AVE GULFPORT, MS 39502 Site 13 of 15 in cluster P	ERNS	2007311759	N/A	
Relative: Lower				<a href="#">Click this hyperlink</a> while viewing on your computer to access additional ERNS detail in the EDR Site Report.				
Actual: 6 ft.	-----							
P106	East	1/4-1/2	0.343 mi. 1812 ft.	991 23RD AVE GULFPORT, MS 39502 Site 14 of 15 in cluster P	ERNS	2008889394	N/A	
Relative: Lower				<a href="#">Click this hyperlink</a> while viewing on your computer to access additional ERNS detail in the EDR Site Report.				
Actual: 6 ft.	-----							
Q107	WSW	1/4-1/2	0.344 mi. 1815 ft.	3315 WEST BEACH BLVD GULFPORT, MS 39501 Site 1 of 5 in cluster Q	ERNS	2000528583	N/A	
Relative: Higher				<a href="#">Click this hyperlink</a> while viewing on your computer to access additional ERNS detail in the EDR Site Report.				
Actual: 10 ft.	-----							

MAP FINDINGS

Map ID Direction Distance Elevation	Site	Database(s)	EDR ID Number EPA ID Number
Q108 WSW 1/4-1/2 0.344 mi. 1815 ft.	3315 WEST BEACH BLVD GULFPORT, MS 39501  Site 2 of 5 in cluster Q	ERNS	2001563253 N/A
Relative: Higher	<a href="#">Click this hyperlink</a> while viewing on your computer to access additional ERNS detail in the EDR Site Report.		
Actual: 10 ft. Q109 WSW 1/4-1/2 0.344 mi. 1815 ft.	3315 WEST BEACH BLVD GULFPORT, MS 39501  Site 3 of 5 in cluster Q	ERNS	2002604092 N/A
Relative: Higher	<a href="#">Click this hyperlink</a> while viewing on your computer to access additional ERNS detail in the EDR Site Report.		
Actual: 10 ft. Q110 WSW 1/4-1/2 0.344 mi. 1815 ft.	3315 WEST BEACH BLVD GULFPORT, MS 0  Site 4 of 5 in cluster Q	ERNS	2002624478 N/A
Relative: Higher	<a href="#">Click this hyperlink</a> while viewing on your computer to access additional ERNS detail in the EDR Site Report.		
Actual: 10 ft. Q111 WSW 1/4-1/2 0.351 mi. 1853 ft.	3315 WEST BEACH BLVD GULF PORT, MS 0  Site 5 of 5 in cluster Q	ERNS	2000546241 N/A
Relative: Higher	<a href="#">Click this hyperlink</a> while viewing on your computer to access additional ERNS detail in the EDR Site Report.		
Actual: 10 ft. O112 NNW 1/4-1/2 0.366 mi. 1930 ft.	GULFPORT PAPER 3019 15TH STREET GULFPORT, MS 39501  Site 2 of 3 in cluster O	FINDS	1016019028 N/A
Relative: Higher	FINDS: Registry ID: 110044510507		
Actual: 23 ft.	Environmental Interest/Information System MS-ENSITE (Mississippi - Tools For Environmental Management And Protection Organizations). Mississippi Department of Environmental Quality (MDEQ) Office of Pollution Control's (OPC) maintains enSite. It is the electronic Environmental Site Information System that that regulates compliance assurance, permitting, activity tracking, and maintenance of a single agency interest-link to definition master file.		

MAP FINDINGS

Map ID  
Direction  
Distance  
Elevation

Site

Database(s)

EDR ID Number  
EPA ID Number

**O113**      **GULFPORT PAPER**  
**NNW**      **3019 15TH STREET**  
**1/4-1/2**    **GULFPORT, MS 39501**  
**0.366 mi.**  
**1930 ft.**    **Site 3 of 3 in cluster O**

**UST**    **U001299665**  
          **N/A**

**Relative:**  
**Higher**

UST:  
Facility ID: 733  
Facility Status: Inactive  
Latitude: 30 22' 9.0000"  
Longitude: 89 5' 54.0000"  
Permanently Out of Use Tanks: 2  
Active Tanks: 0  
AIID: 31088  
Owner Name: Not reported  
Owner Address: Not reported  
Owner Tele: Not reported

**Actual:**  
**23 ft.**

Tank:  
Tank No: 1  
Tank ID: 1920  
**Tank Status: Permanently Out of Use**  
Tank Capacity: 500  
Date Installed: 01/01/1970  
Substance: Gasoline  
Reported Release: Not reported  
Close Type: Closed  
Date Removed: 11/01/1997  
Close Type: 11/01/1997  
Tank Material: Asphalt Coated or Bare Steel  
2nd Containmnt: None  
Tank Lead Detection: N/A  
Overfill Protection: No  
Spill Prevention: No

Pipe:  
Tank No: 1  
Tank Id: 1920  
Pipe Id: 1  
Pipe Status: Permanently Out of Use  
Type Of Closure: Closed  
Pipe Material Construction: Unknown  
Secondary Pipe Material: None  
Piping Type: N/A  
Pipe Leak Detection: Not Listed

Tank:  
Tank No: 2  
Tank ID: 1921  
**Tank Status: Permanently Out of Use**  
Tank Capacity: 250  
Date Installed: 01/01/1988  
Substance: Gasoline  
Reported Release: Not reported  
Close Type: Closed  
Date Removed: 11/28/1997  
Close Type: 11/28/1997

Map ID  
Direction  
Distance  
Elevation

MAP FINDINGS

Site

Database(s)

EDR ID Number  
EPA ID Number

**GULFPORT PAPER (Continued)**

**U001299665**

Tank Material: Unknown  
2nd Containmnt: None  
Tank Lead Detection: N/A  
Overfill Protection: No  
Spill Prevention: No

Pipe:  
Tank No: 2  
Tank Id: 1921  
Pipe Id: 2  
Pipe Status: Permanently Out of Use  
Type Of Closure: Closed  
Pipe Material Construction: Unknown  
Secondary Pipe Material: None  
Piping Type: N/A  
Pipe Leak Detection: Not Listed

114  
North  
1/4-1/2  
0.374 mi.  
1977 ft.

**FEB DISTRIBUTING COMPANY**  
**1520 29TH AVENUE**  
**GULFPORT, MS 39502**

**UST U001297788**  
**N/A**

**Relative:**  
**Higher**

UST:  
Facility ID: 2160  
Facility Status: Inactive  
Latitude: 30 22' 11.0000"  
Longitude: 89 5' 48.0000"  
Permanently Out of Use Tanks: 1  
Active Tanks: 0  
AIID: 31013  
Owner Name: Feb Distributing Company  
Owner Address: PO Box 1139  
Owner Tele: (228)863-0422

**Actual:**  
**23 ft.**

Tank:  
Tank No: 1  
Tank ID: 4943  
**Tank Status: Permanently Out of Use**  
Tank Capacity: 1000  
Date Installed: 01/01/1956  
Substance: Gasoline  
Reported Release: Not reported  
Close Type: Closed  
Date Removed: 08/09/1991  
Close Type: 08/09/1991  
Tank Material: Unknown  
2nd Containmnt: None  
Tank Lead Detection: N/A  
Overfill Protection: No  
Spill Prevention: No

Pipe:  
Tank No: 1  
Tank Id: 4943  
Pipe Id: 1  
Pipe Status: Permanently Out of Use

Map ID  
 Direction  
 Distance  
 Elevation

MAP FINDINGS

Site

Database(s)

EDR ID Number  
 EPA ID Number

**FEB DISTRIBUTING COMPANY (Continued)**

**U001297788**

Type Of Closure: Closed  
 Pipe Material Construction: Unknown  
 Secondary Pipe Material: None  
 Piping Type: N/A  
 Pipe Leak Detection: Not Listed

**R115  
 NNW  
 1/4-1/2  
 0.377 mi.  
 1989 ft.**

**1512 30TH AVE  
 GULFPORT, MS 39501**

**EDR US Hist Cleaners 1014996916**

**N/A**

**Site 1 of 2 in cluster R**

**Relative:  
 Higher**

EDR Historical Cleaners:  
 Name: APEX LAUNDRY  
 Year: 2007

**Actual:  
 23 ft.**

Address: 1512 30TH AVE

**R116  
 NNW  
 1/4-1/2  
 0.380 mi.  
 2008 ft.**

**1518 30TH AVE  
 GULFPORT, MS 39501**

**EDR US Hist Cleaners 1014997158**

**N/A**

**Site 2 of 2 in cluster R**

**Relative:  
 Higher**

EDR Historical Cleaners:  
 Name: APEX LAUNDRY  
 Year: 1999

**Actual:  
 23 ft.**

Address: 1518 30TH AVE

Name: APEX LAUNDRY  
 Year: 2000  
 Address: 1518 30TH AVE

Name: APEX LAUNDRY  
 Year: 2002  
 Address: 1518 30TH AVE

**S117  
 NE  
 1/4-1/2  
 0.383 mi.  
 2023 ft.**

**MARKHAM HOTEL  
 GULFPORT, MS**

**SHWS S117405554**

**N/A**

**Site 1 of 2 in cluster S**

**Relative:  
 Higher**

SHWS:  
 Lat/Long (dms): 30 22 3 / 89 5 26  
 Site Size (acres): <1

**Actual:  
 19 ft.**

EPA ID: Not reported  
 Project Manager: Not reported  
**Status: Not reported**  
 State No Further Action Date: Not reported  
 Federal: Not reported  
 Federal No Further Action Date: Not reported  
 Soil Contamination: No  
 Surface Water Contamination: No  
 Ground Water Contamination: No

Map ID  
Direction  
Distance  
Elevation

MAP FINDINGS

Site

Database(s)

EDR ID Number  
EPA ID Number

**MARKHAM HOTEL (Continued)**

**S117405554**

Remediation Type: Not reported  
Surface Water Remediation: Not reported  
GW Remediation Type: Not reported  
Maj. Contaminant: Recognized Environmental Conditions  
High Concentration: Not reported  
High Concentration Units: Not reported  
Institutional Control: Not reported  
Engineering Control: Not reported  
Voluntary Cleanups: Not reported

**118**  
**NNE**  
**1/4-1/2**  
**0.389 mi.**  
**2056 ft.**

**2510 16TH ST**  
**GULFPORT, MS 39501**

**EDR US Hist Auto Stat 1015364558**  
**N/A**

**Relative:**  
**Higher**

EDR Historical Auto Stations:

Name: ALBERTS AUTOMOTIVE  
Year: 2001  
Address: 2510 16TH ST

**Actual:**  
**26 ft.**

**P119**  
**East**  
**1/4-1/2**  
**0.392 mi.**  
**2068 ft.**

**JOSEPH T JONES HARBOR**  
**2265 JONES PARK DRIVE**  
**GULFPORT, MS 39501**

**LUST U003775525**  
**UST N/A**

**Site 15 of 15 in cluster P**

**Relative:**  
**Lower**

Facility Id: 12311  
Facility Status: Inactive  
Lust Status: Closed  
AIIID: 26501  
Event #: 1  
Project Manager: Michael Usry  
Date Of Report: 10/17/2006  
Trust Fund Status: Katrina  
Confirmed On: 12/08/2006  
NFA Date: 12/13/2006

**Actual:**  
**5 ft.**

UST:

Facility ID: 12311  
Facility Status: Inactive  
Latitude: 30 21' 53.9000"  
Longitude: 89 5' 20.9000"  
Permanently Out of Use Tanks: 4  
Active Tanks: 0  
AIIID: 26501  
Owner Name: City of Gulfport  
Owner Address: 2309 15th Street  
Owner Tele: (228)868-0377

Tank:

Tank No: 1  
Tank ID: 30686  
**Tank Status: Permanently Out of Use**

Map ID  
Direction  
Distance  
Elevation

MAP FINDINGS

Site

Database(s)

EDR ID Number  
EPA ID Number

**JOSEPH T JONES HARBOR (Continued)**

**U003775525**

Tank Capacity: 2000  
Date Installed: 10/01/1978  
Substance: Gasoline  
Reported Release: Yes  
Close Type: Not reported  
Date Removed: 08/29/2005  
Close Type: 05/30/2009  
Tank Material: Fiberglass Reinforced Plastic  
2nd Containmnt: None  
Tank Lead Detection: Groundwater/Vapor Monitoring  
Overfill Protection: Yes  
Spill Prevention: Yes

Pipe:

Tank No: 1  
Tank Id: 30686  
Pipe Id: 1  
Pipe Status: Permanently Out of Use  
Type Of Closure: Not reported  
Pipe Material Construction: Fiberglass Reinforced Plastic  
Secondary Pipe Material: Double-Walled  
Piping Type: Safe Suction  
Pipe Leak Detection: Not reported

Tank:

Tank No: 2  
Tank ID: 30687  
**Tank Status: Permanently Out of Use**  
Tank Capacity: 2000  
Date Installed: 10/01/1978  
Substance: Gasoline  
Reported Release: Yes  
Close Type: Not reported  
Date Removed: 08/29/2005  
Close Type: 05/30/2009  
Tank Material: Fiberglass Reinforced Plastic  
2nd Containmnt: None  
Tank Lead Detection: Groundwater/Vapor Monitoring  
Overfill Protection: Yes  
Spill Prevention: Yes

Pipe:

Tank No: 2  
Tank Id: 30687  
Pipe Id: 2  
Pipe Status: Permanently Out of Use  
Type Of Closure: Not reported  
Pipe Material Construction: Fiberglass Reinforced Plastic  
Secondary Pipe Material: Double-Walled  
Piping Type: Safe Suction  
Pipe Leak Detection: Not reported

Tank:



Map ID  
Direction  
Distance  
Elevation

MAP FINDINGS

Site

Database(s)

EDR ID Number  
EPA ID Number

JOSEPH T JONES HARBOR (Continued)

U003775525

Tank No: 3  
Tank ID: 30688  
**Tank Status: Permanently Out of Use**  
Tank Capacity: 4000  
Date Installed: 10/01/1978  
Substance: Diesel  
Reported Release: Yes  
Close Type: Not reported  
Date Removed: 08/29/2005  
Close Type: 05/30/2009  
Tank Material: Fiberglass Reinforced Plastic  
2nd Containmnt: None  
Tank Lead Detection: Groundwater/Vapor Monitoring  
Overfill Protection: Yes  
Spill Prevention: Yes

Pipe:

Tank No: 3  
Tank Id: 30688  
Pipe Id: 3  
Pipe Status: Permanently Out of Use  
Type Of Closure: Not reported  
Pipe Material Construction: Fiberglass Reinforced Plastic  
Secondary Pipe Material: Double-Walled  
Piping Type: Pressurized  
Pipe Leak Detection: Groundwater/Vapor Monitoring

Tank:

Tank No: 4  
Tank ID: 30689  
**Tank Status: Permanently Out of Use**  
Tank Capacity: 4000  
Date Installed: 10/01/1978  
Substance: Diesel  
Reported Release: Yes  
Close Type: Not reported  
Date Removed: 08/29/2005  
Close Type: 05/30/2009  
Tank Material: Asphalt Coated or Bare Steel  
2nd Containmnt: Cathodically Protected  
Tank Lead Detection: Groundwater/Vapor Monitoring  
Overfill Protection: Yes  
Spill Prevention: Yes

Pipe:

Tank No: 4  
Tank Id: 30689  
Pipe Id: 4  
Pipe Status: Permanently Out of Use  
Type Of Closure: Not reported  
Pipe Material Construction: Fiberglass Reinforced Plastic  
Secondary Pipe Material: Double-Walled  
Piping Type: Safe Suction  
Pipe Leak Detection: Not reported

MAP FINDINGS

Map ID  
Direction  
Distance  
Elevation

Site

Database(s)

EDR ID Number  
EPA ID Number

**S120**  
**NE**  
**1/4-1/2**  
**0.418 mi.**  
**2206 ft.**

**SALVAGE NINE**  
**2317 14TH STREET**  
**GULFPORT, MS 39501**  
  
**Site 2 of 2 in cluster S**

**FINDS** **1016018814**  
**N/A**

**Relative:**  
**Higher**

FINDS:

Registry ID: 110044507744

**Actual:**  
**20 ft.**

Environmental Interest/Information System

MS-ENSITE (Mississippi - Tools For Environmental Management And Protection Organizations). Mississippi Department of Environmental Quality (MDEQ) Office of Pollution Control's (OPC) maintains enSite. It is the electronic Environmental Site Information System that that regulates compliance assurance, permitting, activity tracking, and maintenance of a single agency interest-link to definition master file.

**121**  
**WSW**  
**1/4-1/2**  
**0.427 mi.**  
**2253 ft.**

**E-Z SERVE #4390**  
**3416 WEST HIGHWAY 90**  
**GULFPORT, MS 39501**

**LUST** **U001302961**  
**UST** **N/A**

**Relative:**  
**Higher**

Facility Id: 3057  
Facility Status: Inactive  
Lust Status: Closed  
AIID: 31077  
Event #: 1  
Project Manager: Larry Flynt  
Date Of Report: 01/13/1994  
Trust Fund Status: EUD  
Confirmed On: 02/03/1994  
NFA Date: 02/07/1994

**Actual:**  
**13 ft.**

Facility Id: 3057  
Facility Status: Inactive  
Lust Status: Closed  
AIID: 31077  
Event #: 2  
Project Manager: Robert Huckaby  
Date Of Report: 06/25/1997  
Trust Fund Status: EUD  
Confirmed On: 01/09/1997  
NFA Date: 12/16/1997

UST:

Facility ID: 3057  
Facility Status: Inactive  
Latitude: 30 22' 29.0000"  
Longitude: 89 3' 49.0000"  
Permanently Out of Use Tanks: 11  
Active Tanks: 0  
AIID: 31077  
Owner Name: Not reported  
Owner Address: Not reported

Map ID  
Direction  
Distance  
Elevation

MAP FINDINGS

Site

Database(s)

EDR ID Number  
EPA ID Number

**E-Z SERVE #4390 (Continued)**

**U001302961**

Owner Tele: Not reported

Tank:

Tank No: 1  
Tank ID: 7082  
**Tank Status: Permanently Out of Use**  
Tank Capacity: 10027  
Date Installed: 01/01/1981  
Substance: Gasoline  
Reported Release: Yes  
Close Type: Closed  
Date Removed: 11/19/1996  
Close Type: 11/19/1996  
Tank Material: Asphalt Coated or Bare Steel  
2nd Containmnt: None  
Tank Lead Detection: Statistical Inventory Reconciliation(SIR)  
Overfill Protection: No  
Spill Prevention: No

Pipe:

Tank No: 1  
Tank Id: 7082  
Pipe Id: 1  
Pipe Status: Permanently Out of Use  
Type Of Closure: Closed  
Pipe Material Construction: Bare/Galvanized Steel  
Secondary Pipe Material: None  
Piping Type: Pressurized  
Pipe Leak Detection: Statistical Inventory Reconciliation(SIR)

Tank:

Tank No: 2  
Tank ID: 7083  
**Tank Status: Permanently Out of Use**  
Tank Capacity: 10027  
Date Installed: 01/01/1981  
Substance: Gasoline  
Reported Release: Yes  
Close Type: Closed  
Date Removed: 11/19/1996  
Close Type: 11/19/1996  
Tank Material: Asphalt Coated or Bare Steel  
2nd Containmnt: None  
Tank Lead Detection: Statistical Inventory Reconciliation(SIR)  
Overfill Protection: No  
Spill Prevention: No

Pipe:

Tank No: 2  
Tank Id: 7083  
Pipe Id: 2  
Pipe Status: Permanently Out of Use  
Type Of Closure: Closed  
Pipe Material Construction: Bare/Galvanized Steel  
Secondary Pipe Material: None

Map ID  
Direction  
Distance  
Elevation

MAP FINDINGS

Site

Database(s)

EDR ID Number  
EPA ID Number

**E-Z SERVE #4390 (Continued)**

**U001302961**

Piping Type: Pressurized  
Pipe Leak Detection: Statistical Inventory Reconciliation(SIR)

Tank:

Tank No: 3  
Tank ID: 7084  
**Tank Status: Permanently Out of Use**  
Tank Capacity: 10027  
Date Installed: 01/01/1981  
Substance: Gasoline  
Reported Release: Yes  
Close Type: Closed  
Date Removed: 11/20/1996  
Close Type: 11/20/1996  
Tank Material: Asphalt Coated or Bare Steel  
2nd Containmnt: None  
Tank Lead Detection: Statistical Inventory Reconciliation(SIR)  
Overfill Protection: No  
Spill Prevention: No

Pipe:

Tank No: 3  
Tank Id: 7084  
Pipe Id: 3  
Pipe Status: Permanently Out of Use  
Type Of Closure: Closed  
Pipe Material Construction: Bare/Galvanized Steel  
Secondary Pipe Material: None  
Piping Type: Pressurized  
Pipe Leak Detection: Statistical Inventory Reconciliation(SIR)

Tank:

Tank No: 4  
Tank ID: 7085  
**Tank Status: Permanently Out of Use**  
Tank Capacity: 500  
Date Installed: Not reported  
Substance: Gasoline  
Reported Release: Yes  
Close Type: Closed  
Date Removed: 01/01/1988  
Close Type: 11/20/1996  
Tank Material: Unknown  
2nd Containmnt: None  
Tank Lead Detection: N/A  
Overfill Protection: No  
Spill Prevention: No

Pipe:

Tank No: 4  
Tank Id: 7085  
Pipe Id: 4  
Pipe Status: Permanently Out of Use

Map ID  
Direction  
Distance  
Elevation

MAP FINDINGS

Site

Database(s)

EDR ID Number  
EPA ID Number

**E-Z SERVE #4390 (Continued)**

**U001302961**

Type Of Closure: Closed  
Pipe Material Construction: Unknown  
Secondary Pipe Material: None  
Piping Type: N/A  
Pipe Leak Detection: Not Listed

Tank:

Tank No: 5  
Tank ID: 7086  
**Tank Status: Permanently Out of Use**  
Tank Capacity: 4000  
Date Installed: Not reported  
Substance: Gasoline  
Reported Release: Yes  
Close Type: Closed  
Date Removed: 01/01/1988  
Close Type: 11/20/1996  
Tank Material: Unknown  
2nd Containmnt: None  
Tank Lead Detection: N/A  
Overfill Protection: No  
Spill Prevention: No

Pipe:

Tank No: 5  
Tank Id: 7086  
Pipe Id: 5  
Pipe Status: Permanently Out of Use  
Type Of Closure: Closed  
Pipe Material Construction: Unknown  
Secondary Pipe Material: None  
Piping Type: N/A  
Pipe Leak Detection: Not Listed

Tank:

Tank No: 6  
Tank ID: 7087  
**Tank Status: Permanently Out of Use**  
Tank Capacity: 4000  
Date Installed: Not reported  
Substance: Gasoline  
Reported Release: Yes  
Close Type: Closed  
Date Removed: 01/01/1988  
Close Type: 11/20/1996  
Tank Material: Unknown  
2nd Containmnt: None  
Tank Lead Detection: N/A  
Overfill Protection: No  
Spill Prevention: No

Pipe:

Tank No: 6

Map ID  
Direction  
Distance  
Elevation

MAP FINDINGS

Site

Database(s)

EDR ID Number  
EPA ID Number

**E-Z SERVE #4390 (Continued)**

**U001302961**

Tank Id: 7087  
Pipe Id: 6  
Pipe Status: Permanently Out of Use  
Type Of Closure: Closed  
Pipe Material Construction: Unknown  
Secondary Pipe Material: None  
Piping Type: N/A  
Pipe Leak Detection: Not Listed

Tank:  
Tank No: 7  
Tank ID: 7088  
**Tank Status: Permanently Out of Use**  
Tank Capacity: 4000  
Date Installed: Not reported  
Substance: Gasoline  
Reported Release: Yes  
Close Type: Closed  
Date Removed: 01/01/1988  
Close Type: 11/20/1996  
Tank Material: Unknown  
2nd Containmnt: None  
Tank Lead Detection: N/A  
Overfill Protection: No  
Spill Prevention: No

Pipe:  
Tank No: 7  
Tank Id: 7088  
Pipe Id: 7  
Pipe Status: Permanently Out of Use  
Type Of Closure: Closed  
Pipe Material Construction: Unknown  
Secondary Pipe Material: None  
Piping Type: N/A  
Pipe Leak Detection: Not Listed

Tank:  
Tank No: 8  
Tank ID: 7089  
**Tank Status: Permanently Out of Use**  
Tank Capacity: 4000  
Date Installed: Not reported  
Substance: Gasoline  
Reported Release: Yes  
Close Type: Closed  
Date Removed: 01/01/1988  
Close Type: 11/20/1996  
Tank Material: Unknown  
2nd Containmnt: None  
Tank Lead Detection: N/A  
Overfill Protection: No  
Spill Prevention: No

Map ID  
Direction  
Distance  
Elevation

MAP FINDINGS

Site

Database(s)

EDR ID Number  
EPA ID Number

**E-Z SERVE #4390 (Continued)**

**U001302961**

Pipe:

Tank No: 8  
Tank Id: 7089  
Pipe Id: 8  
Pipe Status: Permanently Out of Use  
Type Of Closure: Closed  
Pipe Material Construction: Unknown  
Secondary Pipe Material: None  
Piping Type: N/A  
Pipe Leak Detection: Not Listed

Tank:

Tank No: 9  
Tank ID: 7090  
**Tank Status: Permanently Out of Use**  
Tank Capacity: 500  
Date Installed: Not reported  
Substance: Gasoline  
Reported Release: Yes  
Close Type: Closed  
Date Removed: 01/01/1988  
Close Type: 11/20/1996  
Tank Material: Unknown  
2nd Containmnt: None  
Tank Lead Detection: N/A  
Overfill Protection: No  
Spill Prevention: No

Pipe:

Tank No: 9  
Tank Id: 7090  
Pipe Id: 9  
Pipe Status: Permanently Out of Use  
Type Of Closure: Closed  
Pipe Material Construction: Unknown  
Secondary Pipe Material: None  
Piping Type: N/A  
Pipe Leak Detection: Not Listed

Tank:

Tank No: 10  
Tank ID: 7091  
**Tank Status: Permanently Out of Use**  
Tank Capacity: 4000  
Date Installed: Not reported  
Substance: Gasoline  
Reported Release: Yes  
Close Type: Closed  
Date Removed: 01/01/1988  
Close Type: 11/20/1996  
Tank Material: Unknown  
2nd Containmnt: None

Map ID  
Direction  
Distance  
Elevation

MAP FINDINGS

Site

Database(s)

EDR ID Number  
EPA ID Number

**E-Z SERVE #4390 (Continued)**

**U001302961**

Tank Lead Detection: N/A  
Overfill Protection: No  
Spill Prevention: No

Pipe:

Tank No: 10  
Tank Id: 7091  
Pipe Id: 10  
Pipe Status: Permanently Out of Use  
Type Of Closure: Closed  
Pipe Material Construction: Unknown  
Secondary Pipe Material: None  
Piping Type: N/A  
Pipe Leak Detection: Not Listed

Tank:

Tank No: 11  
Tank ID: 7092  
**Tank Status: Permanently Out of Use**  
Tank Capacity: 4000  
Date Installed: Not reported  
Substance: Gasoline  
Reported Release: Yes  
Close Type: Closed  
Date Removed: 01/01/1988  
Close Type: 11/20/1996  
Tank Material: Unknown  
2nd Containmnt: None  
Tank Lead Detection: N/A  
Overfill Protection: No  
Spill Prevention: No

Pipe:

Tank No: 11  
Tank Id: 7092  
Pipe Id: 11  
Pipe Status: Permanently Out of Use  
Type Of Closure: Closed  
Pipe Material Construction: Unknown  
Secondary Pipe Material: None  
Piping Type: N/A  
Pipe Leak Detection: Not Listed

T122  
NE  
1/4-1/2  
0.449 mi.  
2373 ft.

1422 23RD AVE  
GULFPORT, MS  
Site 1 of 5 in cluster T

ERNS 94374341  
N/A

Relative:  
Higher

[Click this hyperlink](#) while viewing on your computer to access additional ERNS detail in the EDR Site Report.

Actual:  
20 ft.



MAP FINDINGS

Map ID			EDR ID Number
Direction			EPA ID Number
Distance			
Elevation	Site	Database(s)	

<b>T123</b> <b>NE</b> <b>1/4-1/2</b> <b>0.449 mi.</b> <b>2373 ft.</b>	<b>JOSEPH T JONES BUILDING</b> <b>1422 23RD AVENUE</b> <b>GULFPORT, MS 39501</b>  <b>Site 2 of 5 in cluster T</b>	<b>FINDS</b>	<b>1016017902</b> <b>N/A</b>
---	---	--------------	---------------------------------

**Relative:** **Higher** FINDS:

Registry ID: 110044698253

**Actual:** **20 ft.** Environmental Interest/Information System

MS-ENSITE (Mississippi - Tools For Environmental Management And Protection Organizations). Mississippi Department of Environmental Quality (MDEQ) Office of Pollution Control's (OPC) maintains enSite. It is the electronic Environmental Site Information System that that regulates compliance assurance, permitting, activity tracking, and maintenance of a single agency interest-link to definition master file.

<b>T124</b> <b>NE</b> <b>1/4-1/2</b> <b>0.470 mi.</b> <b>2483 ft.</b>	<b>GULFPORT, MS, CITY OF (SEWER SYSTEM)</b> <b>2309 15TH STREET</b> <b>GULFPORT, MS 39501</b>  <b>Site 3 of 5 in cluster T</b>	<b>ICIS</b> <b>FINDS</b>	<b>1011565979</b> <b>N/A</b>
---	--	-----------------------------	---------------------------------

**Relative:** **Higher** ICIS:

Enforcement Action ID: 04-2005-4768

FRS ID: 110022320996

Program ID: FRS 110022320996

Action Name: GULFPORT, MS, CITY OF, SEWER SYSTEM

Full Address: 2309 15TH STREET GULFPORT MS 39501-2027

State: Mississippi

Facility Name: GULFPORT, MS, CITY OF (SEWER SYSTEM)

Facility Address: 2309 15TH STREET  
GULFPORT, MS 39501-2027

Enforcement Action Type: CWA 309A AO For Compliance

Facility County: HARRISON

EPA Region #: 4

Program ID: FRS 110022320996

Facility Name: GULFPORT, MS, CITY OF (SEWER SYSTEM)

Address: 2309 15TH STREET

Tribal Indicator: N

Fed Facility: Not reported

NAIC Code: Not reported

SIC Code: 4952

**FINDS:**

Registry ID: 110022320996

Environmental Interest/Information System

ICIS (Integrated Compliance Information System) is the Integrated Compliance Information System and provides a database that, when complete, will contain integrated Enforcement and Compliance information across most of EPA's programs. The vision for ICIS is to replace EPA's independent databases that contain Enforcement data with

Map ID  
 Direction  
 Distance  
 Elevation

MAP FINDINGS

Site

Database(s)

EDR ID Number  
 EPA ID Number

**GULFPORT, MS, CITY OF (SEWER SYSTEM) (Continued)**

**1011565979**

a single repository for that information. Currently, ICIS contains all Federal Administrative and Judicial enforcement actions. This information is maintained in ICIS by EPA in the Regional offices and it Headquarters. A future release of ICIS will replace the Permit Compliance System (PCS) which supports the NPDES and will integrate that information with Federal actions already in the system. ICIS also has the capability to track other activities occurring in the Region that support Compliance and Enforcement programs. These include; Incident Tracking, Compliance Assistance, and Compliance Monitoring.

**T125  
 NE  
 1/4-1/2  
 0.470 mi.  
 2483 ft.**

**GULFPORT CENTRAL FIRE STATION  
 2309 15TH STREET  
 GULFPORT, MS 39501  
 Site 4 of 5 in cluster T**

**UST U003775001  
 N/A**

**Relative:  
 Higher**

UST:  
 Facility ID: 11645  
 Facility Status: Inactive  
 Latitude: 30 22' 10.0000"  
 Longitude: 89 5' 23.0000"  
 Permanently Out of Use Tanks: 2  
 Active Tanks: 0  
 AIID: 30999  
 Owner Name: City of Gulfport  
 Owner Address: 2309 15th Street  
 Owner Tele: (228)868-0377

**Actual:  
 23 ft.**

Tank:  
 Tank No: 1  
 Tank ID: 29286  
**Tank Status: Permanently Out of Use**  
 Tank Capacity: 2000  
 Date Installed: 01/01/1976  
 Substance: Gasoline  
 Reported Release: Not reported  
 Close Type: Closed  
 Date Removed: 05/26/1995  
 Close Type: 05/26/1995  
 Tank Material: Unknown  
 2nd Containmnt: None  
 Tank Lead Detection: N/A  
 Overfill Protection: No  
 Spill Prevention: No

Pipe:  
 Tank No: 1  
 Tank Id: 29286  
 Pipe Id: 1  
 Pipe Status: Permanently Out of Use  
 Type Of Closure: Closed  
 Pipe Material Construction: Unknown  
 Secondary Pipe Material: None  
 Piping Type: N/A  
 Pipe Leak Detection: Not Listed

Map ID  
Direction  
Distance  
Elevation

MAP FINDINGS

Site

Database(s)

EDR ID Number  
EPA ID Number

**GULFPORT CENTRAL FIRE STATION (Continued)**

**U003775001**

Tank:

Tank No: 2  
Tank ID: 29287  
**Tank Status: Permanently Out of Use**  
Tank Capacity: 1000  
Date Installed: 01/01/1976  
Substance: Diesel  
Reported Release: Not reported  
Close Type: Closed  
Date Removed: 05/26/1995  
Close Type: 05/26/1995  
Tank Material: Unknown  
2nd Containmnt: None  
Tank Lead Detection: N/A  
Overfill Protection: No  
Spill Prevention: No

Pipe:

Tank No: 2  
Tank Id: 29287  
Pipe Id: 2  
Pipe Status: Permanently Out of Use  
Type Of Closure: Closed  
Pipe Material Construction: Unknown  
Secondary Pipe Material: None  
Piping Type: N/A  
Pipe Leak Detection: Not Listed

T126  
NE  
1/4-1/2  
0.470 mi.  
2483 ft.

**GULFPORT CENTRAL FIRE STATION  
2309 15TH STREET  
GULFPORT, MS 39501  
Site 5 of 5 in cluster T**

**FINDS 1016008383  
N/A**

**Relative:  
Higher**

FINDS:

Registry ID: 110044499496

**Actual:  
23 ft.**

Environmental Interest/Information System

MS-ENSITE (Mississippi - Tools For Environmental Management And Protection Organizations). Mississippi Department of Environmental Quality (MDEQ) Office of Pollution Control's (OPC) maintains enSite. It is the electronic Environmental Site Information System that that regulates compliance assurance, permitting, activity tracking, and maintenance of a single agency interest-link to definition master file.

Map ID  
Direction  
Distance  
Elevation

MAP FINDINGS

Site

Database(s)

EDR ID Number  
EPA ID Number

127  
NNE  
1/4-1/2  
0.493 mi.  
2603 ft.

2603 17TH ST  
GULFPORT, MS 39501

EDR US Hist Auto Stat 1015372008  
N/A

Relative:  
Higher

EDR Historical Auto Stations:

Name: TURAN FOLEY OLDSMOBILE CADILLAC BODY SHOP  
Year: 2000  
Address: 2603 17TH ST

Name: AUTO UNLIMITED II  
Year: 2004  
Address: 2603 17TH ST

Name: AUTO UNLIMITED INC  
Year: 2005  
Address: 2603 17TH ST

Name: THE PEOPLE WHO CARE AUTO CLINIC INC  
Year: 2007  
Address: 2603 17TH ST

Name: PEOPLE WHO CARE AUTO CLINIC  
Year: 2008  
Address: 2603 17TH ST

Name: PEOPLE WHO CARE AUTO CLINIC  
Year: 2009  
Address: 2603 17TH ST

128  
SE  
1/4-1/2  
0.494 mi.  
2607 ft.

GULFPORT YACHT CLUB PROJECT  
GULFPORT, MS

SHWS S103920412  
N/A

Relative:  
Lower

SHWS:

Lat/Long (dms): 30 21 35 / 89 5 22  
Site Size (acres): >1  
EPA ID: Not reported  
Project Manager: Not reported  
**Status: Inactive**  
State No Further Action Date: Not reported  
Federal: Not reported  
Federal No Further Action Date: Not reported  
Soil Contamination: Yes  
Surface Water Contamination: Yes  
Ground Water Contamination: No  
Remediation Type: Not reported  
Surface Water Remediation: Not reported  
GW Remediation Type: Not reported  
Maj. Contaminant: beta-HCH  
High Concentration: 1.60E+01  
High Concentration Units: mg/kg  
Institutional Control: Not reported  
Engineering Control: Not reported  
Voluntary Cleanups: Not reported

Actual:  
6 ft.

MAP FINDINGS

Map ID Direction Distance Elevation	Site	Database(s)	EDR ID Number EPA ID Number
--	------	-------------	--------------------------------

<b>U129</b> <b>ENE</b> <b>1/4-1/2</b> <b>0.495 mi.</b> <b>2613 ft.</b>	<b>DOWNTOWN SERVICE STATION</b> <b>2201 14TH STREET</b> <b>GULFPORT, MS</b>  <b>Site 1 of 3 in cluster U</b>	<b>RGA LUST</b>	<b>S116269564</b> <b>N/A</b>
--	--	-----------------	---------------------------------

<b>Relative:</b> <b>Higher</b>	<b>Actual:</b> <b>20 ft.</b>	<b>Relative:</b> <b>Higher</b>	<b>RGA LUST:</b> <table border="0" style="width: 100%;"> <tr><td style="width: 5%;">2012</td><td style="width: 45%;">DOWNTOWN SERVICE STATION</td><td style="width: 45%;">2201 14TH STREET</td></tr> <tr><td>2011</td><td>DOWNTOWN SERVICE STATION</td><td>2201 14TH STREET</td></tr> <tr><td>2010</td><td>DOWNTOWN SERVICE STATION</td><td>2201 14TH STREET</td></tr> <tr><td>2009</td><td>DOWNTOWN SERVICE STATION</td><td>2201 14TH STREET</td></tr> <tr><td>2008</td><td>DOWNTOWN SERVICE STATION</td><td>2201 14TH STREET</td></tr> <tr><td>2007</td><td>DOWNTOWN SERVICE STATION</td><td>2201 14TH STREET</td></tr> <tr><td>2006</td><td>DOWNTOWN SERVICE STATION</td><td>2201 14TH STREET</td></tr> <tr><td>2005</td><td>DOWNTOWN SERVICE STATION</td><td>2201 14TH STREET</td></tr> <tr><td>2004</td><td>DOWNTOWN SERVICE STATION</td><td>2201 14TH STREET</td></tr> <tr><td>2003</td><td>DOWNTOWN SERVICE STATION</td><td>2201 14TH STREET</td></tr> </table>	2012	DOWNTOWN SERVICE STATION	2201 14TH STREET	2011	DOWNTOWN SERVICE STATION	2201 14TH STREET	2010	DOWNTOWN SERVICE STATION	2201 14TH STREET	2009	DOWNTOWN SERVICE STATION	2201 14TH STREET	2008	DOWNTOWN SERVICE STATION	2201 14TH STREET	2007	DOWNTOWN SERVICE STATION	2201 14TH STREET	2006	DOWNTOWN SERVICE STATION	2201 14TH STREET	2005	DOWNTOWN SERVICE STATION	2201 14TH STREET	2004	DOWNTOWN SERVICE STATION	2201 14TH STREET	2003	DOWNTOWN SERVICE STATION	2201 14TH STREET
2012	DOWNTOWN SERVICE STATION	2201 14TH STREET																															
2011	DOWNTOWN SERVICE STATION	2201 14TH STREET																															
2010	DOWNTOWN SERVICE STATION	2201 14TH STREET																															
2009	DOWNTOWN SERVICE STATION	2201 14TH STREET																															
2008	DOWNTOWN SERVICE STATION	2201 14TH STREET																															
2007	DOWNTOWN SERVICE STATION	2201 14TH STREET																															
2006	DOWNTOWN SERVICE STATION	2201 14TH STREET																															
2005	DOWNTOWN SERVICE STATION	2201 14TH STREET																															
2004	DOWNTOWN SERVICE STATION	2201 14TH STREET																															
2003	DOWNTOWN SERVICE STATION	2201 14TH STREET																															

<b>U130</b> <b>ENE</b> <b>1/4-1/2</b> <b>0.495 mi.</b> <b>2613 ft.</b>	<b>2201 14TH ST</b> <b>GULFPORT, MS 39501</b>  <b>Site 2 of 3 in cluster U</b>	<b>EDR US Hist Auto Stat</b>	<b>1015333414</b> <b>N/A</b>
--	---	------------------------------	---------------------------------

<b>Relative:</b> <b>Higher</b>	<b>Actual:</b> <b>20 ft.</b>	<b>Relative:</b> <b>Higher</b>	<b>EDR Historical Auto Stations:</b> <table border="0" style="width: 100%;"> <tr><td style="width: 15%;">Name:</td><td style="width: 40%;">DOWNTOWN SERVICE STATION</td><td style="width: 45%;"></td></tr> <tr><td>Year:</td><td>1999</td><td></td></tr> <tr><td>Address:</td><td>2201 14TH ST</td><td></td></tr> <tr><td colspan="3"> </td></tr> <tr><td>Name:</td><td>DOWNTOWN SERVICE STATION</td><td></td></tr> <tr><td>Year:</td><td>2000</td><td></td></tr> <tr><td>Address:</td><td>2201 14TH ST</td><td></td></tr> <tr><td colspan="3"> </td></tr> <tr><td>Name:</td><td>DOWNTOWN SERVICE STATION</td><td></td></tr> <tr><td>Year:</td><td>2001</td><td></td></tr> <tr><td>Address:</td><td>2201 14TH ST</td><td></td></tr> <tr><td colspan="3"> </td></tr> <tr><td>Name:</td><td>DOWNTOWN SERVICE STATION</td><td></td></tr> <tr><td>Year:</td><td>2002</td><td></td></tr> <tr><td>Address:</td><td>2201 14TH ST</td><td></td></tr> <tr><td colspan="3"> </td></tr> <tr><td>Name:</td><td>DOWNTOWN SERVICE STATION</td><td></td></tr> <tr><td>Year:</td><td>2003</td><td></td></tr> <tr><td>Address:</td><td>2201 14TH ST</td><td></td></tr> </table>	Name:	DOWNTOWN SERVICE STATION		Year:	1999		Address:	2201 14TH ST					Name:	DOWNTOWN SERVICE STATION		Year:	2000		Address:	2201 14TH ST					Name:	DOWNTOWN SERVICE STATION		Year:	2001		Address:	2201 14TH ST					Name:	DOWNTOWN SERVICE STATION		Year:	2002		Address:	2201 14TH ST					Name:	DOWNTOWN SERVICE STATION		Year:	2003		Address:	2201 14TH ST	
Name:	DOWNTOWN SERVICE STATION																																																											
Year:	1999																																																											
Address:	2201 14TH ST																																																											
Name:	DOWNTOWN SERVICE STATION																																																											
Year:	2000																																																											
Address:	2201 14TH ST																																																											
Name:	DOWNTOWN SERVICE STATION																																																											
Year:	2001																																																											
Address:	2201 14TH ST																																																											
Name:	DOWNTOWN SERVICE STATION																																																											
Year:	2002																																																											
Address:	2201 14TH ST																																																											
Name:	DOWNTOWN SERVICE STATION																																																											
Year:	2003																																																											
Address:	2201 14TH ST																																																											

<b>U131</b> <b>ENE</b> <b>1/4-1/2</b> <b>0.495 mi.</b> <b>2613 ft.</b>	<b>DOWNTOWN SERVICE STATION</b> <b>2201 14TH STREET</b> <b>GULFPORT, MS 39501</b>  <b>Site 3 of 3 in cluster U</b>	<b>LUST</b> <b>UST</b>	<b>U003774161</b> <b>N/A</b>
--	--	---------------------------	---------------------------------

<b>Relative:</b> <b>Higher</b>	<b>Actual:</b> <b>20 ft.</b>	<b>Relative:</b> <b>Higher</b>	<table border="0" style="width: 100%;"> <tr><td style="width: 15%;">Facility Id:</td><td style="width: 40%;">10749</td><td style="width: 45%;"></td></tr> <tr><td>Facility Satus:</td><td>Inactive</td><td></td></tr> <tr><td>Lust Status:</td><td>Open</td><td></td></tr> <tr><td>AIID:</td><td>26499</td><td></td></tr> <tr><td>Event #:</td><td>1</td><td></td></tr> <tr><td>Project Manager:</td><td>Joseph Curro</td><td></td></tr> <tr><td>Date Of Report:</td><td>08/05/2003</td><td></td></tr> </table>	Facility Id:	10749		Facility Satus:	Inactive		Lust Status:	Open		AIID:	26499		Event #:	1		Project Manager:	Joseph Curro		Date Of Report:	08/05/2003	
Facility Id:	10749																							
Facility Satus:	Inactive																							
Lust Status:	Open																							
AIID:	26499																							
Event #:	1																							
Project Manager:	Joseph Curro																							
Date Of Report:	08/05/2003																							

Map ID  
Direction  
Distance  
Elevation

MAP FINDINGS

Site

Database(s)

EDR ID Number  
EPA ID Number

**DOWNTOWN SERVICE STATION (Continued)**

**U003774161**

Trust Fund Status: STFS  
Confirmed On: 08/06/2003  
NFA Date: Not reported

UST:

Facility ID: 10749  
Facility Status: Inactive  
Latitude: 30 22' 4.9000"  
Longitude: 89 5' 21.3000"  
Permanently Out of Use Tanks: 3  
Active Tanks: 0  
AIID: 26499  
Owner Name: Stewart Sneed Hewes/Bancorp South Insurance  
Owner Address: PO Box 250  
Owner Tele: (228)863-5362

Tank:

Tank No: 1  
Tank ID: 27255  
**Tank Status: Permanently Out of Use**  
Tank Capacity: 6000  
Date Installed: 01/01/1975  
Substance: Gasoline  
Reported Release: Yes  
Close Type: Not reported  
Date Removed: 11/01/2003  
Close Type: 09/04/2003  
Tank Material: Epoxy Coated Steel  
2nd Containmnt: Cathodically Protected  
Tank Lead Detection: Groundwater/Vapor Monitoring  
Overfill Protection: Yes  
Spill Prevention: Yes

Pipe:

Tank No: 1  
Tank Id: 27255  
Pipe Id: 1  
Pipe Status: Permanently Out of Use  
Type Of Closure: Not reported  
Pipe Material Construction: Bare/Galvanized Steel  
Secondary Pipe Material: Cathodically Protected  
Piping Type: Pressurized  
Pipe Leak Detection: Groundwater/Vapor Monitoring

Tank:

Tank No: 2  
Tank ID: 27256  
**Tank Status: Permanently Out of Use**  
Tank Capacity: 6000  
Date Installed: 01/01/1975  
Substance: Gasoline  
Reported Release: Yes  
Close Type: Not reported  
Date Removed: 01/02/2001

Map ID  
Direction  
Distance  
Elevation

MAP FINDINGS

Site

Database(s)

EDR ID Number  
EPA ID Number

**DOWNTOWN SERVICE STATION (Continued)**

**U003774161**

Close Type: 09/04/2003  
Tank Material: Epoxy Coated Steel  
2nd Containmnt: Cathodically Protected  
Tank Lead Detection: Groundwater/Vapor Monitoring  
Overfill Protection: Yes  
Spill Prevention: Yes

Pipe:  
Tank No: 2  
Tank Id: 27256  
Pipe Id: 2  
Pipe Status: Permanently Out of Use  
Type Of Closure: Not reported  
Pipe Material Construction: Bare/Galvanized Steel  
Secondary Pipe Material: Cathodically Protected  
Piping Type: Pressurized  
Pipe Leak Detection: Groundwater/Vapor Monitoring

Tank:  
Tank No: 3  
Tank ID: 27257  
**Tank Status: Permanently Out of Use**  
Tank Capacity: 6000  
Date Installed: 01/01/1975  
Substance: Diesel  
Reported Release: Yes  
Close Type: Not reported  
Date Removed: 11/01/2003  
Close Type: 09/04/2003  
Tank Material: Epoxy Coated Steel  
2nd Containmnt: Cathodically Protected  
Tank Lead Detection: Groundwater/Vapor Monitoring  
Overfill Protection: Yes  
Spill Prevention: Yes

Pipe:  
Tank No: 3  
Tank Id: 27257  
Pipe Id: 3  
Pipe Status: Permanently Out of Use  
Type Of Closure: Not reported  
Pipe Material Construction: Bare/Galvanized Steel  
Secondary Pipe Material: Cathodically Protected  
Piping Type: Pressurized  
Pipe Leak Detection: Groundwater/Vapor Monitoring

MAP FINDINGS

Map ID  
Direction  
Distance  
Elevation

Site

Database(s)

EDR ID Number  
EPA ID Number

V132  
NE  
1/4-1/2  
0.496 mi.  
2620 ft.

**GULFPORT POLICE OPERATIONS BUILDING**  
**1520 23RD AVENUE**  
**GULFPORT, MS 39501**

**UST U003775435**  
**N/A**

**Site 1 of 2 in cluster V**

**Relative:**  
**Higher**

UST:  
Facility ID: 12194  
Facility Status: Inactive  
Latitude: 30 22' 10.0000"  
Longitude: 89 5' 25.0000"  
Permanently Out of Use Tanks: 1  
Active Tanks: 0  
AIID: 30995  
Owner Name: City of Gulfport Police Dept  
Owner Address: PO Drawer S  
Owner Tele: (228)868-5906

**Actual:**  
**23 ft.**

Tank:  
Tank No: 1  
Tank ID: 30448  
**Tank Status: Permanently Out of Use**  
Tank Capacity: 550  
Date Installed: Not reported  
Substance: Diesel  
Reported Release: Not reported  
Close Type: Closed  
Date Removed: 08/17/1999  
Close Type: 08/24/1999  
Tank Material: Asphalt Coated or Bare Steel  
2nd Containmnt: None  
Tank Lead Detection: Deferred  
Overfill Protection: No  
Spill Prevention: No

Pipe:  
Tank No: 1  
Tank Id: 30448  
Pipe Id: 1  
Pipe Status: Permanently Out of Use  
Type Of Closure: Closed  
Pipe Material Construction: Bare/Galvanized Steel  
Secondary Pipe Material: None  
Piping Type: U.S. Suction  
Pipe Leak Detection: Deferred

V133  
NE  
1/4-1/2  
0.496 mi.  
2620 ft.

**GULFPORT POLICE OPERATIONS BUILDING**  
**1520 23RD AVENUE**  
**GULFPORT, MS 39501**

**FINDS 1016002718**  
**N/A**

**Site 2 of 2 in cluster V**

**Relative:**  
**Higher**

FINDS:  
Registry ID: 110044499389  
Environmental Interest/Information System  
MS-ENSITE (Mississippi - Tools For Environmental Management And  
Protection Organizations). Mississippi Department of Environmental

**Actual:**  
**23 ft.**



Map ID  
Direction  
Distance  
Elevation

MAP FINDINGS

Site

Database(s)

EDR ID Number  
EPA ID Number

**GULFPORT POLICE OPERATIONS BUILDING (Continued)**

**1016002718**

Quality (MDEQ) Office of Pollution Control's (OPC) maintains enSite. It is the electronic Environmental Site Information System that regulates compliance assurance, permitting, activity tracking, and maintenance of a single agency interest-link to definition master file.

134  
NW  
1/4-1/2  
0.498 mi.  
2627 ft.

3317 15TH ST  
GULFPORT, MS 39501

EDR US Hist Auto Stat

1015431483

N/A

Relative:  
Higher

EDR Historical Auto Stations:

Name: COAST AUTO AIR INC  
Year: 2012

Actual:  
26 ft.

Address: 3317 15TH ST

W135  
NNE  
1/2-1  
0.520 mi.  
2746 ft.

TURAN-FOLEY CADILLAC MOTORS  
1708 25TH AVENUE  
GULFPORT, MS 39505

LUST

U001298221

UST

N/A

Site 1 of 2 in cluster W

Relative:  
Higher

Facility Id: 2983  
Facility Status: Inactive  
Lust Status: Closed  
AIID: 27171  
Event #: 1  
Project Manager: Amanda Easley  
Date Of Report: 05/24/1999  
Trust Fund Status: NTFE  
Confirmed On: 05/13/1999  
NFA Date: 12/12/2000

Actual:  
23 ft.

UST:

Facility ID: 2983  
Facility Status: Inactive  
Latitude: 30 22' 18.9300"  
Longitude: 89 5' 31.9800"  
Permanently Out of Use Tanks: 1  
Active Tanks: 0  
AIID: 27171  
Owner Name: Not reported  
Owner Address: Not reported  
Owner Tele: Not reported

Tank:

Tank No: 1  
Tank ID: 6891  
Tank Status: Permanently Out of Use  
Tank Capacity: 2000  
Date Installed: 01/01/1971  
Substance: Gasoline

Map ID  
Direction  
Distance  
Elevation

MAP FINDINGS

Site

Database(s)

EDR ID Number  
EPA ID Number

**TURAN-FOLEY CADILLAC MOTORS (Continued)**

**U001298221**

Reported Release: Yes  
Close Type: Closed  
Date Removed: 08/25/2000  
Close Type: 08/25/2000  
Tank Material: Asphalt Coated or Bare Steel  
2nd Containmnt: Cathodically Protected  
Tank Lead Detection: Groundwater/Vapor Monitoring  
Overfill Protection: Yes  
Spill Prevention: Yes

Pipe:

Tank No: 1  
Tank Id: 6891  
Pipe Id: 1  
Pipe Status: Permanently Out of Use  
Type Of Closure: Closed  
Pipe Material Construction: Bare/Galvanized Steel  
Secondary Pipe Material: Cathodically Protected  
Piping Type: Safe Suction  
Pipe Leak Detection: N/A

**W136**  
**NNE**  
**1/2-1**  
**0.520 mi.**  
**2746 ft.**

**TURAN FOLEY OLDS - CADILLAC**  
**1708 25TH AVENUE**  
**GULFPORT, MS 39501**

**RCRA NonGen / NLR 1000474979**  
**MSD033319401**

**Site 2 of 2 in cluster W**

**Relative:**  
**Higher**

RCRA NonGen / NLR:

Date form received by agency: 02/03/2010  
Facility name: TURAN FOLEY OLDS - CADILLAC  
Facility address: 1708 25TH AVENUE  
GULFPORT, MS 39501  
EPA ID: MSD033319401  
Mailing address: P.O. BOX 219  
GULFPORT, MS 395020219  
Contact: TIM SUTHERLIN  
Contact address: 1708 25TH AVENUE  
GULFPORT, MS 39501  
Contact country: US  
Contact telephone: (601) 863-4104  
Contact email: Not reported  
EPA Region: 04  
Land type: Facility is not located on Indian land. Additional information is not known.  
Classification: Non-Generator  
Description: Handler: Non-Generators do not presently generate hazardous waste

**Actual:**  
**23 ft.**

Owner/Operator Summary:

Owner/operator name: HOLLIS CARR  
Owner/operator address: Not reported  
Not reported  
Owner/operator country: Not reported  
Owner/operator telephone: Not reported  
Legal status: Private  
Owner/Operator Type: Owner  
Owner/Op start date: Not reported  
Owner/Op end date: Not reported

Map ID  
Direction  
Distance  
Elevation

MAP FINDINGS

Site

Database(s)

EDR ID Number  
EPA ID Number

**TURAN FOLEY OLDS - CADILLAC (Continued)**

**1000474979**

Handler Activities Summary:

U.S. importer of hazardous waste: No  
Mixed waste (haz. and radioactive): No  
Recycler of hazardous waste: No  
Transporter of hazardous waste: No  
Treater, storer or disposer of HW: No  
Underground injection activity: No  
On-site burner exemption: No  
Furnace exemption: No  
Used oil fuel burner: No  
Used oil processor: No  
User oil refiner: No  
Used oil fuel marketer to burner: No  
Used oil Specification marketer: No  
Used oil transfer facility: No  
Used oil transporter: No

Historical Generators:

Date form received by agency: 05/20/1997

Site name: TURAN FOLEY OLDS - CADILLAC

Classification: Small Quantity Generator

. Waste code: F003

. Waste name: THE FOLLOWING SPENT NONHALOGENATED SOLVENTS: XYLENE, ACETONE, ETHYL ACETATE, ETHYL BENZENE, ETHYL ETHER, METHYL ISOBUTYL KETONE, N-BUTYL ALCOHOL, CYCLOHEXANONE, AND METHANOL; ALL SPENT SOLVENT MIXTURES/BLENDS CONTAINING, BEFORE USE, ONLY THE ABOVE SPENT NONHALOGENATED SOLVENTS; AND ALL SPENT SOLVENT MIXTURES/BLENDS CONTAINING, BEFORE USE, ONE OR MORE OF THE ABOVE NONHALOGENATED SOLVENTS, AND A TOTAL OF TEN PERCENT OR MORE (BY VOLUME) OF ONE OR MORE OF THOSE SOLVENTS LISTED IN F001, F002, F004, AND F005; AND STILL BOTTOMS FROM THE RECOVERY OF THESE SPENT SOLVENTS AND SPENT SOLVENT MIXTURES.

. Waste code: F005

. Waste name: THE FOLLOWING SPENT NONHALOGENATED SOLVENTS: TOLUENE, METHYL ETHYL KETONE, CARBON DISULFIDE, ISOBUTANOL, PYRIDINE, BENZENE, 2-ETHOXYETHANOL, AND 2-NITROPROPANE; ALL SPENT SOLVENT MIXTURES/BLENDS CONTAINING, BEFORE USE, A TOTAL OF TEN PERCENT OR MORE (BY VOLUME) OF ONE OR MORE OF THE ABOVE NONHALOGENATED SOLVENTS OR THOSE SOLVENTS LISTED IN F001, F002, OR F004; AND STILL BOTTOMS FROM THE RECOVERY OF THESE SPENT SOLVENTS AND SPENT SOLVENT MIXTURES.

Violation Status: No violations found

Evaluation Action Summary:

Evaluation date: 05/11/2010  
Evaluation: COMPLIANCE EVALUATION INSPECTION ON-SITE  
Area of violation: Not reported  
Date achieved compliance: Not reported  
Evaluation lead agency: State

MAP FINDINGS

Map ID  
 Direction  
 Distance  
 Elevation

Site

Database(s)

EDR ID Number  
 EPA ID Number

**X137**      **GULF CITIES GAS CO**      **EDR MGP**      **1008408973**  
**NE**      **23RD AVE**      **N/A**  
**1/2-1**      **GULFPORT, MS 39501**  
**0.523 mi.**  
**2761 ft.**      **Site 1 of 2 in cluster X**

**Relative:**      Manufactured Gas Plants:  
**Higher**      Alternate Name:SOUTHWESTERN GAS AND ELECTRIC. No additional information available

**Actual:** \_\_\_\_\_  
**26 ft.**

**138**      **MCBC GULFPORT FAMILY HOUSING**      **RCRA-CESQG**      **1012182891**  
**WSW**      **3502 EAST 8TH STREET, BLDG 452**      **MSR000104349**  
**1/2-1**      **GULFPORT, MS 39501**  
**0.534 mi.**  
**2819 ft.**

**Relative:**      RCRA-CESQG:  
**Higher**      Date form received by agency: 11/11/2008  
Facility name:      MCBC GULFPORT FAMILY HOUSING  
**Actual:**      Facility address:      3502 EAST 8TH STREET, BLDG 452  
**17 ft.**      GULFPORT, MS 39501  
EPA ID:      MSR000104349  
Mailing address:      EAST 8TH STREET, BLDG 452  
GULFPORT, MS 39501  
Contact:      KENNETH E PHILLIPS  
Contact address:      EAST 8TH STREET, BLDG 452  
GULFPORT, MS 39501  
Contact country:      US  
Contact telephone:      (228) 863-0424  
Contact email:      Not reported  
EPA Region:      04  
Classification:      Conditionally Exempt Small Quantity Generator  
Description:      Handler: generates 100 kg or less of hazardous waste per calendar month, and accumulates 1000 kg or less of hazardous waste at any time; or generates 1 kg or less of acutely hazardous waste per calendar month, and accumulates at any time: 1 kg or less of acutely hazardous waste; or 100 kg or less of any residue or contaminated soil, waste or other debris resulting from the cleanup of a spill, into or on any land or water, of acutely hazardous waste; or generates 100 kg or less of any residue or contaminated soil, waste or other debris resulting from the cleanup of a spill, into or on any land or water, of acutely hazardous waste during any calendar month, and accumulates at any time: 1 kg or less of acutely hazardous waste; or 100 kg or less of any residue or contaminated soil, waste or other debris resulting from the cleanup of a spill, into or on any land or water, of acutely hazardous waste

**Owner/Operator Summary:**  
Owner/operator name:      SOUTHEAST HOUSING LLC  
Owner/operator address:      Not reported  
Not reported  
Owner/operator country:      Not reported  
Owner/operator telephone:      Not reported  
Legal status:      Private  
Owner/Operator Type:      Operator  
Owner/Op start date:      10/01/2007  
Owner/Op end date:      Not reported  
  
Owner/operator name:      SOUTHEAST HOUSING LLC  
Owner/operator address:      Not reported

Map ID  
Direction  
Distance  
Elevation

MAP FINDINGS

Site

Database(s)

EDR ID Number  
EPA ID Number

**MCBC GULFPORT FAMILY HOUSING (Continued)**

**1012182891**

Owner/operator country: Not reported  
Owner/operator telephone: Not reported  
Legal status: Private  
Owner/Operator Type: Owner  
Owner/Op start date: 10/01/2007  
Owner/Op end date: Not reported

Handler Activities Summary:

U.S. importer of hazardous waste: No  
Mixed waste (haz. and radioactive): No  
Recycler of hazardous waste: No  
Transporter of hazardous waste: No  
Treater, storer or disposer of HW: No  
Underground injection activity: No  
On-site burner exemption: No  
Furnace exemption: No  
Used oil fuel burner: No  
Used oil processor: No  
User oil refiner: No  
Used oil fuel marketer to burner: No  
Used oil Specification marketer: No  
Used oil transfer facility: No  
Used oil transporter: No

. Waste code: D001  
. Waste name: IGNITABLE WASTE

. Waste code: D004  
. Waste name: ARSENIC

. Waste code: F002  
. Waste name: THE FOLLOWING SPENT HALOGENATED SOLVENTS: TETRACHLOROETHYLENE, METHYLENE CHLORIDE, TRICHLOROETHYLENE, 1,1,1-TRICHLOROETHANE, CHLOROBENZENE, 1,1,2-TRICHLORO-1,2,2-TRIFLUOROETHANE, ORTHO-DICHLOROBENZENE, TRICHLOROFLUOROMETHANE, AND 1,1,2, TRICHLOROETHANE; ALL SPENT SOLVENT MIXTURES/BLENDS CONTAINING, BEFORE USE, A TOTAL OF TEN PERCENT OR MORE (BY VOLUME) OF ONE OR MORE OF THE ABOVE HALOGENATED SOLVENTS OR THOSE SOLVENTS LISTED IN F001, F004, AND F005; AND STILL BOTTOMS FROM THE RECOVERY OF THESE SPENT SOLVENTS AND SPENT SOLVENT MIXTURES.

. Waste code: F003  
. Waste name: THE FOLLOWING SPENT NONHALOGENATED SOLVENTS: XYLENE, ACETONE, ETHYL ACETATE, ETHYL BENZENE, ETHYL ETHER, METHYL ISOBUTYL KETONE, N-BUTYL ALCOHOL, CYCLOHEXANONE, AND METHANOL; ALL SPENT SOLVENT MIXTURES/BLENDS CONTAINING, BEFORE USE, ONLY THE ABOVE SPENT NONHALOGENATED SOLVENTS; AND ALL SPENT SOLVENT MIXTURES/BLENDS CONTAINING, BEFORE USE, ONE OR MORE OF THE ABOVE NONHALOGENATED SOLVENTS, AND A TOTAL OF TEN PERCENT OR MORE (BY VOLUME) OF ONE OR MORE OF THOSE SOLVENTS LISTED IN F001, F002, F004, AND F005; AND STILL BOTTOMS FROM THE RECOVERY OF THESE SPENT SOLVENTS AND SPENT SOLVENT MIXTURES.

. Waste code: F005  
. Waste name: THE FOLLOWING SPENT NONHALOGENATED SOLVENTS: TOLUENE, METHYL ETHYL KETONE, CARBON DISULFIDE, ISOBUTANOL, PYRIDINE, BENZENE,

Map ID  
Direction  
Distance  
Elevation

MAP FINDINGS

Site

Database(s)

EDR ID Number  
EPA ID Number

MCBC GULFPORT FAMILY HOUSING (Continued)

1012182891

2-ETHOXYETHANOL, AND 2-NITROPROPANE; ALL SPENT SOLVENT MIXTURES/BLENDS CONTAINING, BEFORE USE, A TOTAL OF TEN PERCENT OR MORE (BY VOLUME) OF ONE OR MORE OF THE ABOVE NONHALOGENATED SOLVENTS OR THOSE SOLVENTS LISTED IN F001, F002, OR F004; AND STILL BOTTOMS FROM THE RECOVERY OF THESE SPENT SOLVENTS AND SPENT SOLVENT MIXTURES.

Violation Status: No violations found

X139  
NE  
1/2-1  
0.544 mi.  
2870 ft.

VERIZON BUSINESS INC  
1608 23RD AVENUE  
GULFPORT, MS 39501

UST U001300638  
N/A

Site 2 of 2 in cluster X

Relative:  
Higher

UST:

Facility ID: 6715  
Facility Status: Active  
Latitude: 30 22' 15.9900"  
Longitude: 89 5' 21.4600"  
Permanently Out of Use Tanks: 1  
Active Tanks: 1  
AIID: 26495  
Owner Name: MCI- Jason Weller  
Owner Address: 2400 N Glenville Drive  
Owner Tele: (972)729-5441

Actual:  
25 ft.

Tank:

Tank No: 1  
Tank ID: 16906  
**Tank Status: Permanently Out of Use**  
Tank Capacity: 1000  
Date Installed: 01/01/1984  
Substance: Diesel  
Reported Release: Not reported  
Close Type: Closed  
Date Removed: 07/15/1993  
Close Type: 07/15/1993  
Tank Material: Asphalt Coated or Bare Steel  
2nd Containmnt: None  
Tank Lead Detection: N/A  
Overfill Protection: No  
Spill Prevention: No

Pipe:

Tank No: 1  
Tank Id: 16906  
Pipe Id: 1  
Pipe Status: Permanently Out of Use  
Type Of Closure: Closed  
Pipe Material Construction: Bare/Galvanized Steel  
Secondary Pipe Material: None  
Piping Type: N/A  
Pipe Leak Detection: Not Listed

Tank:

Tank No: 2

Map ID  
Direction  
Distance  
Elevation

MAP FINDINGS

Site

Database(s)

EDR ID Number  
EPA ID Number

**VERIZON BUSINESS INC (Continued)**

**U001300638**

Tank ID: 16907  
**Tank Status:** **Currently In Use**  
Tank Capacity: 1000  
Date Installed: 08/01/1993  
Substance: Diesel  
Reported Release: Not reported  
Close Type: Not reported  
Date Removed: Not reported  
Close Type: Not reported  
Tank Material: Fiberglass Reinforced Plastic  
2nd Containmnt: Double-Walled  
Tank Lead Detection: Deferred  
Overfill Protection: Yes  
Spill Prevention: Yes

Pipe:

Tank No: 2  
Tank Id: 16907  
Pipe Id: 2  
Pipe Status: Currently In Use  
Type Of Closure: Not reported  
Pipe Material Construction: Flexible Plastic  
Secondary Pipe Material: Double-Walled  
Piping Type: U.S. Suction  
Pipe Leak Detection: Deferred

140  
NNE  
1/2-1  
0.560 mi.  
2959 ft.

**HARRISON COUNTY - CURBSIDE RECYCLING PROGRAM  
COUNTY CURBSIDE PICKUP  
GULFPORT, MS**

**SWRCY S106560554  
N/A**

**Relative:  
Higher**

SWRCY:

Contact Name: Paul Vanderfin  
Contact Phone: 228/868-8752  
Contact Fax: 228/868-8752  
Contact EMail: 228/868-8752  
Item Recycled: Aluminum Cans, Steel Cans, Newspaper, Plastic Bottles (milk, soda, and waterbottles), Glass Bottles, Mixed paper(phone books, magazines)

**Actual:  
23 ft.**

Y141  
NNE  
1/2-1  
0.585 mi.  
3090 ft.

**GOODYEAR AUTO SERVICE CENTER  
1809 25TH AVENUE  
GULFPORT, MS 39501**

**RCRA-CESQG 1004742680  
MSD981857766**

**Relative:  
Higher**

RCRA-CESQG:

Date form received by agency: 10/27/1986  
Facility name: GOODYEAR AUTO SERVICE CENTER  
Facility address: 1809 25TH AVENUE  
GULFPORT, MS 39501  
EPA ID: MSD981857766  
Mailing address: DAKIN STREET  
JEFFERSON, LA 70181  
Contact: E.R. GRIFFIN  
Contact address: 1000 DAKIN STREET

**Actual:  
23 ft.**

Map ID  
Direction  
Distance  
Elevation

MAP FINDINGS

Site

Database(s)

EDR ID Number  
EPA ID Number

**GOODYEAR AUTO SERVICE CENTER (Continued)**

**1004742680**

JEFFERSON, LA 70181  
Contact country: US  
Contact telephone: (504) 838-4700  
Contact email: Not reported  
EPA Region: 04  
Classification: Conditionally Exempt Small Quantity Generator  
Description: Handler: generates 100 kg or less of hazardous waste per calendar month, and accumulates 1000 kg or less of hazardous waste at any time; or generates 1 kg or less of acutely hazardous waste per calendar month, and accumulates at any time: 1 kg or less of acutely hazardous waste; or 100 kg or less of any residue or contaminated soil, waste or other debris resulting from the cleanup of a spill, into or on any land or water, of acutely hazardous waste; or generates 100 kg or less of any residue or contaminated soil, waste or other debris resulting from the cleanup of a spill, into or on any land or water, of acutely hazardous waste during any calendar month, and accumulates at any time: 1 kg or less of acutely hazardous waste; or 100 kg or less of any residue or contaminated soil, waste or other debris resulting from the cleanup of a spill, into or on any land or water, of acutely hazardous waste

Owner/Operator Summary:

Owner/operator name: GOODYEAR TIRE & RUBBER COMPANY  
Owner/operator address: Not reported  
Not reported  
Owner/operator country: Not reported  
Owner/operator telephone: Not reported  
Legal status: Private  
Owner/Operator Type: Owner  
Owner/Op start date: Not reported  
Owner/Op end date: Not reported

Handler Activities Summary:

U.S. importer of hazardous waste: No  
Mixed waste (haz. and radioactive): No  
Recycler of hazardous waste: No  
Transporter of hazardous waste: No  
Treater, storer or disposer of HW: No  
Underground injection activity: No  
On-site burner exemption: No  
Furnace exemption: No  
Used oil fuel burner: No  
Used oil processor: No  
User oil refiner: No  
Used oil fuel marketer to burner: No  
Used oil Specification marketer: No  
Used oil transfer facility: No  
Used oil transporter: No

. Waste code: D001  
. Waste name: IGNITABLE WASTE

. Waste code: F002  
. Waste name: THE FOLLOWING SPENT HALOGENATED SOLVENTS: TETRACHLOROETHYLENE, METHYLENE CHLORIDE, TRICHLOROETHYLENE, 1,1,1-TRICHLOROETHANE, CHLOROBENZENE, 1,1,2-TRICHLORO-1,2,2-TRIFLUOROETHANE,



Map ID  
Direction  
Distance  
Elevation

MAP FINDINGS

Site

Database(s)

EDR ID Number  
EPA ID Number

**GOODYEAR AUTO SERVICE CENTER (Continued)**

**1004742680**

ORTHO-DICHLOROBENZENE, TRICHLOROFLUOROMETHANE, AND 1,1,2, TRICHLOROETHANE; ALL SPENT SOLVENT MIXTURES/BLENDS CONTAINING, BEFORE USE, A TOTAL OF TEN PERCENT OR MORE (BY VOLUME) OF ONE OR MORE OF THE ABOVE HALOGENATED SOLVENTS OR THOSE SOLVENTS LISTED IN F001, F004, AND F005; AND STILL BOTTOMS FROM THE RECOVERY OF THESE SPENT SOLVENTS AND SPENT SOLVENT MIXTURES.

Violation Status: No violations found

Y142  
NNE  
1/2-1  
0.585 mi.  
3090 ft.

**GOODYEAR ASC 2733  
1809 25TH AVENUE  
GULFPORT, MS 39501  
Site 2 of 3 in cluster Y**

**UST 1000475397  
N/A**

Relative:  
Higher

UST:

Facility ID: 7930  
Facility Status: Inactive  
Latitude: 30 22' 21.0000"  
Longitude: 89 5' 35.0000"  
Permanently Out of Use Tanks: 1  
Active Tanks: 0  
AIID: 4093  
Owner Name: Goodyear Tire & Rubber Company - Real Estate Dept  
Owner Address: 1144 East Market Street  
Owner Tele: (216)796-2121

Actual:  
23 ft.

Tank:

Tank No: 1  
Tank ID: 20131  
**Tank Status: Permanently Out of Use**  
Tank Capacity: 1000  
Date Installed: 01/01/1981  
Substance: Used Oil  
Reported Release: Not reported  
Close Type: Closed  
Date Removed: 12/29/1993  
Close Type: 12/29/1993  
Tank Material: Asphalt Coated or Bare Steel  
2nd Containmnt: None  
Tank Lead Detection: N/A  
Overfill Protection: No  
Spill Prevention: No

Y143  
NNE  
1/2-1  
0.585 mi.  
3090 ft.

**1809 25TH AVE  
GULFPORT, MS 39501  
Site 3 of 3 in cluster Y**

**EDR US Hist Auto Stat 1015279618  
N/A**

Relative:  
Higher

EDR Historical Auto Stations:

Name: GOODYEAR AUTO SERVICE CENTERS  
Year: 1999  
Address: 1809 25TH AVE

Actual:  
23 ft.

Name: GOODYEAR AUTO SERVICE CENTERS  
Year: 2000

Map ID  
Direction  
Distance  
Elevation

MAP FINDINGS

Site

Database(s)

EDR ID Number  
EPA ID Number

(Continued)

1015279618

Address: 1809 25TH AVE  
Name: GOODYEAR AUTO SERVICE CENTERS  
Year: 2003  
Address: 1809 25TH AVE  
Name: GOODYEAR TIRE CO  
Year: 2004  
Address: 1809 25TH AVE  
Name: GOODYEAR AUTO SERVICE CENTERS  
Year: 2011  
Address: 1809 25TH AVE

Z144  
NE  
1/2-1  
0.589 mi.  
3112 ft.

TURAN LANE CHEVROLET BUICK INC  
2120 15TH STREET  
GULFPORT, MS 39502

LUST U003774154  
UST N/A

Site 1 of 4 in cluster Z

Relative:  
Higher

Actual:  
21 ft.

Facility Id: 10741  
Facility Status: Inactive  
Lust Status: Closed  
AIID: 30964  
Event #: 1  
Project Manager: Larry Flynt  
Date Of Report: 04/16/1990  
Trust Fund Status: NTFE  
Confirmed On: 04/16/1990  
NFA Date: 09/24/1990

UST:

Facility ID: 10741  
Facility Status: Inactive  
Latitude: 30 22' 9.0000"  
Longitude: 89 5' 16.0000"  
Permanently Out of Use Tanks: 2  
Active Tanks: 0  
AIID: 30964  
Owner Name: Turan Lane Chevrolet Buick Inc  
Owner Address: PO Box 190  
Owner Tele: (228)864-7500

Tank:

Tank No: 1  
Tank ID: 27237  
**Tank Status: Permanently Out of Use**  
Tank Capacity: 500  
Date Installed: 01/01/1970  
Substance: Gasoline  
Reported Release: Yes  
Close Type: Closed  
Date Removed: 12/15/1982  
Close Type: 12/15/1987  
Tank Material: Unknown  
2nd Containmnt: None

Map ID  
Direction  
Distance  
Elevation

MAP FINDINGS

Site

Database(s)

EDR ID Number  
EPA ID Number

**TURAN LANE CHEVROLET BUICK INC (Continued)**

**U003774154**

Tank Lead Detection: N/A  
Overfill Protection: No  
Spill Prevention: No

Pipe:

Tank No: 1  
Tank Id: 27237  
Pipe Id: 1  
Pipe Status: Permanently Out of Use  
Type Of Closure: Closed  
Pipe Material Construction: Unknown  
Secondary Pipe Material: None  
Piping Type: N/A  
Pipe Leak Detection: Not Listed

Tank:

Tank No: 2  
Tank ID: 27238  
**Tank Status: Permanently Out of Use**  
Tank Capacity: 500  
Date Installed: 01/01/1970  
Substance: Gasoline  
Reported Release: Yes  
Close Type: Closed  
Date Removed: 12/15/1987  
Close Type: 12/15/1987  
Tank Material: Unknown  
2nd Containmnt: None  
Tank Lead Detection: N/A  
Overfill Protection: No  
Spill Prevention: No

Pipe:

Tank No: 2  
Tank Id: 27238  
Pipe Id: 2  
Pipe Status: Permanently Out of Use  
Type Of Closure: Closed  
Pipe Material Construction: Unknown  
Secondary Pipe Material: None  
Piping Type: N/A  
Pipe Leak Detection: Not Listed

Z145  
NE  
1/2-1  
0.589 mi.  
3112 ft.

2120 15TH ST  
GULFPORT, MS 39501  
Site 2 of 4 in cluster Z

EDR US Hist Auto Stat 1015323767  
N/A

Relative:  
Higher

EDR Historical Auto Stations:  
Name: BUICK GEO BODY SHOP  
Year: 1999  
Address: 2120 15TH ST

Actual:  
21 ft.

Name: BUICK GEO BODY SHOP

Map ID  
Direction  
Distance  
Elevation

MAP FINDINGS

Site

Database(s)

EDR ID Number  
EPA ID Number

(Continued)

1015323767

Year: 2000  
Address: 2120 15TH ST

Z146  
NE  
1/2-1  
0.589 mi.  
3112 ft.

**TURAN-LANE CHEVROLET-BUICK, INC.**  
**2120 15TH STREET**  
**GULFPORT, MS 39501**  
**Site 3 of 4 in cluster Z**

RCRA NonGen / NLR

1004742623  
MSD981021298

Relative:  
Higher

RCRA NonGen / NLR:

Actual:  
21 ft.

Date form received by agency: 07/23/2002  
Facility name: TURAN-LANE CHEVROLET-BUICK, INC.  
Facility address: 2120 15TH STREET  
GULFPORT, MS 39501  
EPA ID: MSD981021298  
Mailing address: 15TH STREET  
GULFPORT, MS 39501  
Contact: CHUCK MORRIS  
Contact address: 2120 15TH STREET  
GULFPORT, MS 39501  
Contact country: US  
Contact telephone: (601) 864-7500  
Contact email: Not reported  
EPA Region: 04  
Classification: Non-Generator  
Description: Handler: Non-Generators do not presently generate hazardous waste

Owner/Operator Summary:

Owner/operator name: JAY JAY MOTOR CO.  
Owner/operator address: Not reported  
Not reported  
Owner/operator country: Not reported  
Owner/operator telephone: Not reported  
Legal status: Private  
Owner/Operator Type: Owner  
Owner/Op start date: Not reported  
Owner/Op end date: Not reported

Handler Activities Summary:

U.S. importer of hazardous waste: No  
Mixed waste (haz. and radioactive): No  
Recycler of hazardous waste: No  
Transporter of hazardous waste: No  
Treater, storer or disposer of HW: No  
Underground injection activity: No  
On-site burner exemption: No  
Furnace exemption: No  
Used oil fuel burner: No  
Used oil processor: No  
User oil refiner: No  
Used oil fuel marketer to burner: No  
Used oil Specification marketer: No  
Used oil transfer facility: No  
Used oil transporter: No

. Waste code: D000  
. Waste name: Not Defined

Map ID  
Direction  
Distance  
Elevation

MAP FINDINGS

Site

Database(s)

EDR ID Number  
EPA ID Number

**TURAN-LANE CHEVROLET-BUICK, INC. (Continued)**

**1004742623**

- . Waste code: D001
- . Waste name: IGNITABLE WASTE
  
- . Waste code: F003
- . Waste name: THE FOLLOWING SPENT NONHALOGENATED SOLVENTS: XYLENE, ACETONE, ETHYL ACETATE, ETHYL BENZENE, ETHYL ETHER, METHYL ISOBUTYL KETONE, N-BUTYL ALCOHOL, CYCLOHEXANONE, AND METHANOL; ALL SPENT SOLVENT MIXTURES/BLENDS CONTAINING, BEFORE USE, ONLY THE ABOVE SPENT NONHALOGENATED SOLVENTS; AND ALL SPENT SOLVENT MIXTURES/BLENDS CONTAINING, BEFORE USE, ONE OR MORE OF THE ABOVE NONHALOGENATED SOLVENTS, AND A TOTAL OF TEN PERCENT OR MORE (BY VOLUME) OF ONE OR MORE OF THOSE SOLVENTS LISTED IN F001, F002, F004, AND F005; AND STILL BOTTOMS FROM THE RECOVERY OF THESE SPENT SOLVENTS AND SPENT SOLVENT MIXTURES.
  
- . Waste code: F005
- . Waste name: THE FOLLOWING SPENT NONHALOGENATED SOLVENTS: TOLUENE, METHYL ETHYL KETONE, CARBON DISULFIDE, ISOBUTANOL, PYRIDINE, BENZENE, 2-ETHOXYETHANOL, AND 2-NITROPROPANE; ALL SPENT SOLVENT MIXTURES/BLENDS CONTAINING, BEFORE USE, A TOTAL OF TEN PERCENT OR MORE (BY VOLUME) OF ONE OR MORE OF THE ABOVE NONHALOGENATED SOLVENTS OR THOSE SOLVENTS LISTED IN F001, F002, OR F004; AND STILL BOTTOMS FROM THE RECOVERY OF THESE SPENT SOLVENTS AND SPENT SOLVENT MIXTURES.

Historical Generators:

Date form received by agency: 03/12/1990  
Site name: TURAN-LANE CHEVROLET-BUICK, INC.  
Classification: Conditionally Exempt Small Quantity Generator

Violation Status: No violations found

147  
NE  
1/2-1  
0.603 mi.  
3185 ft.

**HARDYS SHIP SERVICE  
1600 22ND AVENUE  
GULFPORT, MS 39501**

**RCRA NonGen / NLR 1000475564  
MSD982092801**

Relative:  
Higher

RCRA NonGen / NLR:

Date form received by agency: 08/27/1987  
Facility name: HARDYS SHIP SERVICE  
Facility address: 1600 22ND AVENUE  
GULFPORT, MS 39501  
EPA ID: MSD982092801  
Mailing address: 22ND AVENUE  
GULFPORT, MS 39501  
Contact: R.H. HARDY  
Contact address: 1600 22ND AVENUE  
GULFPORT, MS 39501  
Contact country: US  
Contact telephone: (601) 868-1414  
Contact email: Not reported  
EPA Region: 04  
Classification: Non-Generator  
Description: Handler: Non-Generators do not presently generate hazardous waste

Actual:  
26 ft.

Owner/Operator Summary:

Owner/operator name: RUTH S. & R.H. HARDY SR. INC.  
Owner/operator address: Not reported

Map ID  
Direction  
Distance  
Elevation

MAP FINDINGS

Site

Database(s)

EDR ID Number  
EPA ID Number

**HARDYS SHIP SERVICE (Continued)**

**1000475564**

Owner/operator country: Not reported  
Owner/operator telephone: Not reported  
Legal status: Private  
Owner/Operator Type: Owner  
Owner/Op start date: Not reported  
Owner/Op end date: Not reported

Handler Activities Summary:

U.S. importer of hazardous waste: No  
Mixed waste (haz. and radioactive): No  
Recycler of hazardous waste: No  
Transporter of hazardous waste: No  
Treater, storer or disposer of HW: No  
Underground injection activity: No  
On-site burner exemption: No  
Furnace exemption: No  
Used oil fuel burner: No  
Used oil processor: No  
User oil refiner: No  
Used oil fuel marketer to burner: No  
Used oil Specification marketer: No  
Used oil transfer facility: No  
Used oil transporter: No

. Waste code: D000  
. Waste name: Not Defined  
  
. Waste code: D001  
. Waste name: IGNITABLE WASTE  
  
. Waste code: D002  
. Waste name: CORROSIVE WASTE

Violation Status: No violations found

Z148  
NE  
1/2-1  
0.621 mi.  
3279 ft.

**TURAN FOLEY DEALERSHIP**  
**GULFPORT, MS**  
**Site 4 of 4 in cluster Z**

**SHWS S103920904**  
**N/A**

Relative:  
Higher

SHWS:  
Lat/Long (dms): 30 22 11 / 89 5 15  
Site Size (acres): <1  
EPA ID: Not reported  
Project Manager: Not reported  
**Status: SNFA**  
State No Further Action Date: 04/23/2001  
Federal: Not reported  
Federal No Further Action Date: Not reported  
Soil Contamination: Yes  
Surface Water Contamination: No  
Ground Water Contamination: No  
Remediation Type: Not reported  
Surface Water Remediation: Not reported  
GW Remediation Type: Not reported  
Maj. Contaminant: Chloromethane

Actual:  
23 ft.

Map ID  
Direction  
Distance  
Elevation

MAP FINDINGS

Site

Database(s)

EDR ID Number  
EPA ID Number

**TURAN FOLEY DEALERSHIP (Continued)**

**S103920904**

High Concentration: 1.39E-02  
High Concentration Units: mg/L  
Institutional Control: Not reported  
Engineering Control: Not reported  
Voluntary Cleanups: Not reported

**AA149**  
**North**  
**1/2-1**  
**0.633 mi.**  
**3342 ft.**

**USPS-GULFPORT VMF**  
**2801 19TH STREET**  
**GULFPORT, MS 39501**

**RCRA-CESQG 1004742514**  
**MS0001012160**

**Site 1 of 4 in cluster AA**

**Relative:**  
**Higher**

RCRA-CESQG:

Date form received by agency: 04/15/2003  
Facility name: USPS-GULFPORT VMF  
Facility address: 2801 19TH STREET  
GULFPORT, MS 395012824  
EPA ID: MS0001012160  
Mailing address: 24TH STREET NORTH  
ROOM 282  
BIRMINGHAM, AL 352039361  
Contact: PHILLIP R EDWARDS  
Contact address: 351 24TH STREET NORTH ROOM 282  
BIRMINGHAM, AL 352039361  
Contact country: US  
Contact telephone: (205) 521-0457  
Contact email: Not reported  
EPA Region: 04  
Classification: Conditionally Exempt Small Quantity Generator  
Description: Handler: generates 100 kg or less of hazardous waste per calendar month, and accumulates 1000 kg or less of hazardous waste at any time; or generates 1 kg or less of acutely hazardous waste per calendar month, and accumulates at any time: 1 kg or less of acutely hazardous waste; or 100 kg or less of any residue or contaminated soil, waste or other debris resulting from the cleanup of a spill, into or on any land or water, of acutely hazardous waste; or generates 100 kg or less of any residue or contaminated soil, waste or other debris resulting from the cleanup of a spill, into or on any land or water, of acutely hazardous waste during any calendar month, and accumulates at any time: 1 kg or less of acutely hazardous waste; or 100 kg or less of any residue or contaminated soil, waste or other debris resulting from the cleanup of a spill, into or on any land or water, of acutely hazardous waste

**Actual:**  
**26 ft.**

Owner/Operator Summary:

Owner/operator name: USPS  
Owner/operator address: 351 24TH STREET NORTH ROOM 282  
BIRMINGHAM, AL 35203  
Owner/operator country: US  
Owner/operator telephone: (205) 521-0457  
Legal status: Federal  
Owner/Operator Type: Owner  
Owner/Op start date: 01/23/1995  
Owner/Op end date: Not reported  
  
Owner/operator name: USPS  
Owner/operator address: 351 24TH STREET NORTH ROOM 282

Map ID  
Direction  
Distance  
Elevation

MAP FINDINGS

Site

Database(s)

EDR ID Number  
EPA ID Number

USPS-GULFPORT VMF (Continued)

1004742514

BIRMINGHAM, AL 35203  
Owner/operator country: US  
Owner/operator telephone: (205) 521-0457  
Legal status: Federal  
Owner/Operator Type: Operator  
Owner/Op start date: 01/23/1995  
Owner/Op end date: Not reported

Owner/operator name: US POSTAL SERVICE  
Owner/operator address: 401 E. SOUTH STREET  
JACKSON, MS 39201

Owner/operator country: Not reported  
Owner/operator telephone: (601) 968-5760  
Legal status: Federal  
Owner/Operator Type: Owner  
Owner/Op start date: Not reported  
Owner/Op end date: Not reported

Handler Activities Summary:

U.S. importer of hazardous waste: No  
Mixed waste (haz. and radioactive): No  
Recycler of hazardous waste: No  
Transporter of hazardous waste: No  
Treater, storer or disposer of HW: No  
Underground injection activity: No  
On-site burner exemption: No  
Furnace exemption: No  
Used oil fuel burner: No  
Used oil processor: No  
User oil refiner: No  
Used oil fuel marketer to burner: No  
Used oil Specification marketer: No  
Used oil transfer facility: No  
Used oil transporter: No

. Waste code: D001  
. Waste name: IGNITABLE WASTE

. Waste code: D018  
. Waste name: BENZENE

. Waste code: D035  
. Waste name: METHYL ETHYL KETONE

. Waste code: D039  
. Waste name: TETRACHLOROETHYLENE

. Waste code: D040  
. Waste name: TRICHLOROETHYLENE

. Waste code: F003  
. Waste name: THE FOLLOWING SPENT NONHALOGENATED SOLVENTS: XYLENE, ACETONE, ETHYL ACETATE, ETHYL BENZENE, ETHYL ETHER, METHYL ISOBUTYL KETONE, N-BUTYL ALCOHOL, CYCLOHEXANONE, AND METHANOL; ALL SPENT SOLVENT MIXTURES/BLENDS CONTAINING, BEFORE USE, ONLY THE ABOVE SPENT NONHALOGENATED SOLVENTS; AND ALL SPENT SOLVENT MIXTURES/BLENDS CONTAINING, BEFORE USE, ONE OR MORE OF THE ABOVE NONHALOGENATED



Map ID  
Direction  
Distance  
Elevation

MAP FINDINGS

Site

Database(s)

EDR ID Number  
EPA ID Number

**USPS-GULFPORT VMF (Continued)**

**1004742514**

SOLVENTS, AND A TOTAL OF TEN PERCENT OR MORE (BY VOLUME) OF ONE OR MORE OF THOSE SOLVENTS LISTED IN F001, F002, F004, AND F005; AND STILL BOTTOMS FROM THE RECOVERY OF THESE SPENT SOLVENTS AND SPENT SOLVENT MIXTURES.

- . Waste code: F005
- . Waste name: THE FOLLOWING SPENT NONHALOGENATED SOLVENTS: TOLUENE, METHYL ETHYL KETONE, CARBON DISULFIDE, ISOBUTANOL, PYRIDINE, BENZENE, 2-ETHOXYETHANOL, AND 2-NITROPROPANE; ALL SPENT SOLVENT MIXTURES/BLENDS CONTAINING, BEFORE USE, A TOTAL OF TEN PERCENT OR MORE (BY VOLUME) OF ONE OR MORE OF THE ABOVE NONHALOGENATED SOLVENTS OR THOSE SOLVENTS LISTED IN F001, F002, OR F004; AND STILL BOTTOMS FROM THE RECOVERY OF THESE SPENT SOLVENTS AND SPENT SOLVENT MIXTURES.

Historical Generators:

- Date form received by agency: 01/23/1995
- Site name: US POSTAL SERVICE GULFPORT VMF
- Classification: Conditionally Exempt Small Quantity Generator

- . Waste code: D001
- . Waste name: IGNITABLE WASTE
- . Waste code: D002
- . Waste name: CORROSIVE WASTE

Violation Status: No violations found

**AA150**  
**North**  
**1/2-1**  
**0.633 mi.**  
**3342 ft.**

**GULFPORT VEHICLE MAINTENANCE FAC**  
**2801 19TH STREET**  
**GULFPORT, MS 39501**  
**Site 2 of 4 in cluster AA**

**LUST U001303649**  
**UST N/A**

**Relative:**  
**Higher**

- Facility Id: 6583
- Facility Status: Inactive
- Lust Status: Closed
- AIID: 31065
- Event #: 1
- Project Manager: Larry Flynt
- Date Of Report: 12/12/1988
- Trust Fund Status: STFS
- Confirmed On: 12/12/1988
- NFA Date: 02/26/1990

**Actual:**  
**26 ft.**

UST:

- Facility ID: 6583
- Facility Status: Inactive
- Latitude: 30 22' 42.0000"
- Longitude: 89 5' 66.0000"
- Permanently Out of Use Tanks: 4
- Active Tanks: 0
- AIID: 31065
- Owner Name: US Postal Service
- Owner Address: 2801 19th Street
- Owner Tele: (228)864-1273

Map ID  
Direction  
Distance  
Elevation

MAP FINDINGS

Site

Database(s)

EDR ID Number  
EPA ID Number

**GULFPORT VEHICLE MAINTENANCE FAC (Continued)**

**U001303649**

Tank:

Tank No: 1  
Tank ID: 16622  
**Tank Status: Permanently Out of Use**  
Tank Capacity: 12000  
Date Installed: 01/01/1981  
Substance: Gasoline  
Reported Release: Yes  
Close Type: Closed  
Date Removed: 10/28/1991  
Close Type: 10/28/1991  
Tank Material: Asphalt Coated or Bare Steel  
2nd Containmnt: None  
Tank Lead Detection: N/A  
Overfill Protection: No  
Spill Prevention: No

Pipe:

Tank No: 1  
Tank Id: 16622  
Pipe Id: 1  
Pipe Status: Permanently Out of Use  
Type Of Closure: Closed  
Pipe Material Construction: Bare/Galvanized Steel  
Secondary Pipe Material: None  
Piping Type: N/A  
Pipe Leak Detection: Not Listed

Tank:

Tank No: 2  
Tank ID: 16623  
**Tank Status: Permanently Out of Use**  
Tank Capacity: 1000  
Date Installed: 01/01/1981  
Substance: Used Oil  
Reported Release: Yes  
Close Type: Closed  
Date Removed: 09/03/1991  
Close Type: 10/28/1991  
Tank Material: Asphalt Coated or Bare Steel  
2nd Containmnt: None  
Tank Lead Detection: N/A  
Overfill Protection: No  
Spill Prevention: No

Tank:

Tank No: 3  
Tank ID: 16624  
**Tank Status: Permanently Out of Use**  
Tank Capacity: 1000  
Date Installed: 01/01/1981  
Substance: Gasoline  
Reported Release: Yes

Map ID  
Direction  
Distance  
Elevation

MAP FINDINGS

Site

Database(s)

EDR ID Number  
EPA ID Number

**GULFPORT VEHICLE MAINTENANCE FAC (Continued)**

**U001303649**

Close Type: Closed  
Date Removed: 09/03/1991  
Close Type: 10/28/1991  
Tank Material: Asphalt Coated or Bare Steel  
2nd Containmnt: None  
Tank Lead Detection: N/A  
Overfill Protection: No  
Spill Prevention: No

Pipe:

Tank No: 3  
Tank Id: 16624  
Pipe Id: 3  
Pipe Status: Permanently Out of Use  
Type Of Closure: Closed  
Pipe Material Construction: Bare/Galvanized Steel  
Secondary Pipe Material: None  
Piping Type: N/A  
Pipe Leak Detection: Not Listed

Tank:

Tank No: 4  
Tank ID: 16625  
**Tank Status: Permanently Out of Use**  
Tank Capacity: 12000  
Date Installed: 10/28/1991  
Substance: Gasoline  
Reported Release: Yes  
Close Type: Closed  
Date Removed: 04/27/1999  
Close Type: 04/27/1999  
Tank Material: Fiberglass Reinforced Plastic  
2nd Containmnt: Double-Walled  
Tank Lead Detection: Electronic Interstitial Monitoring  
Overfill Protection: Yes  
Spill Prevention: Yes

Pipe:

Tank No: 4  
Tank Id: 16625  
Pipe Id: 4  
Pipe Status: Permanently Out of Use  
Type Of Closure: Closed  
Pipe Material Construction: Fiberglass Reinforced Plastic  
Secondary Pipe Material: Double-Walled  
Piping Type: U.S. Suction  
Pipe Leak Detection: Visual Interstitial Monitoring

MAP FINDINGS

Map ID  
Direction  
Distance  
Elevation

Site

Database(s)

EDR ID Number  
EPA ID Number

151  
ENE  
1/2-1  
0.635 mi.  
3355 ft.

**BROADWATER SEA COURSE  
2000 EAST BEACH BOULEVARD  
DIBERVILLE, MS 39540**

**UST U001299669  
N/A**

**Relative:  
Higher**

UST:

Facility ID: 738  
Facility Status: Inactive  
Latitude: 30 23' 9.0000"  
Longitude: 89 0' 41.0000"  
Permanently Out of Use Tanks: 2  
Active Tanks: 0  
AIID: 31583  
Owner Name: Eagle Energy Inc  
Owner Address: PO Box 6007  
Owner Tele: (228)896-7252

**Actual:  
15 ft.**

Tank:

Tank No: 1  
Tank ID: 1936  
**Tank Status: Permanently Out of Use**  
Tank Capacity: 1000  
Date Installed: 01/01/1985  
Substance: Gasoline  
Reported Release: Not reported  
Close Type: Closed  
Date Removed: 11/27/1996  
Close Type: 11/27/1996  
Tank Material: Asphalt Coated or Bare Steel  
2nd Containmnt: None  
Tank Lead Detection: Inventory Control/Precision Tightness Testing  
Overfill Protection: No  
Spill Prevention: No

Pipe:

Tank No: 1  
Tank Id: 1936  
Pipe Id: 1  
Pipe Status: Permanently Out of Use  
Type Of Closure: Closed  
Pipe Material Construction: Unknown  
Secondary Pipe Material: None  
Piping Type: U.S. Suction  
Pipe Leak Detection: N/A

Tank:

Tank No: 2  
Tank ID: 1937  
**Tank Status: Permanently Out of Use**  
Tank Capacity: 500  
Date Installed: 01/01/1971  
Substance: Diesel  
Reported Release: Not reported  
Close Type: Closed  
Date Removed: 11/27/1996  
Close Type: 11/27/1996

Map ID  
Direction  
Distance  
Elevation

MAP FINDINGS

Site

Database(s)

EDR ID Number  
EPA ID Number

**BROADWATER SEA COURSE (Continued)**

**U001299669**

Tank Material: Asphalt Coated or Bare Steel  
2nd Containmnt: None  
Tank Lead Detection: Inventory Control/Precision Tightness Testing  
Overfill Protection: No  
Spill Prevention: No

Pipe:

Tank No: 2  
Tank Id: 1937  
Pipe Id: 2  
Pipe Status: Permanently Out of Use  
Type Of Closure: Closed  
Pipe Material Construction: Unknown  
Secondary Pipe Material: None  
Piping Type: U.S. Suction  
Pipe Leak Detection: N/A

---

**AA152**      **19TH STREET FUEL & WASHOUT**  
**North**      **2880 19TH ST**  
**1/2-1**      **GULFPORT, MS 39501**  
**0.636 mi.**  
**3357 ft.**      **Site 3 of 4 in cluster AA**

**AST**      **A100409839**  
**N/A**

**Relative:**  
**Higher**

AST:

Facility ID: Not reported  
Store ID: Not reported  
Contact Name: Not reported  
Contact Telephone: Not reported  
Mailing Address: Not reported  
Mailing City: Not reported  
Mailing State: Not reported  
Mailing Zip: Not reported  
Business Type: Retail Outlet  
Last Inspection Date: Not reported

**Actual:**  
**26 ft.**

---

**153**      **HARRISON COUNTY CIVIL DEFENSE**  
**NNE**      **1801 23RD AVENUE**  
**1/2-1**      **GULFPORT, MS 39502**  
**0.644 mi.**  
**3399 ft.**

**UST**      **U003774615**  
**N/A**

**Relative:**  
**Higher**

UST:

Facility ID: 11222  
Facility Status: Active  
Latitude: 30 22' 20.6000"  
Longitude: 89 5' 28.5000"  
Permanently Out of Use Tanks: 0  
Active Tanks: 1  
AIID: 26146  
Owner Name: Harrison County Civil Defense  
Owner Address: 1801 23rd Avenue  
Owner Tele: (228)865-4002

**Actual:**  
**26 ft.**

Tank:

Tank No: 1

Map ID  
Direction  
Distance  
Elevation

MAP FINDINGS

Site

Database(s)

EDR ID Number  
EPA ID Number

HARRISON COUNTY CIVIL DEFENSE (Continued)

U003774615

Tank ID: 28341  
**Tank Status: Currently In Use**  
Tank Capacity: 4000  
Date Installed: 01/01/1977  
Substance: Diesel  
Reported Release: Not reported  
Close Type: Not reported  
Date Removed: Not reported  
Close Type: Not reported  
Tank Material: Fiberglass Reinforced Plastic  
2nd Containmnt: None  
Tank Lead Detection: Deferred  
Overfill Protection: Yes  
Spill Prevention: Yes

Pipe:

Tank No: 1  
Tank Id: 28341  
Pipe Id: 1  
Pipe Status: Currently In Use  
Type Of Closure: Not reported  
Pipe Material Construction: Bare/Galvanized Steel  
Secondary Pipe Material: Cathodically Protected  
Piping Type: Safe Suction  
Pipe Leak Detection: Not reported

154  
NE  
1/2-1  
0.652 mi.  
3442 ft.

BST GULFPORT CO 77104  
1723 22ND AVENUE  
GULFPORT, MS 39501

UST U003009992  
N/A

Relative:  
Higher

UST:

Facility ID: 9237  
Facility Status: Active  
Latitude: 30 22' 18.1000"  
Longitude: 89 5' 20.3000"  
Permanently Out of Use Tanks: 1  
Active Tanks: 1  
AIID: 16522  
Owner Name: Not reported  
Owner Address: Not reported  
Owner Tele: Not reported

Actual:  
23 ft.

Tank:

Tank No: 1  
Tank ID: 23471  
**Tank Status: Permanently Out of Use**  
Tank Capacity: 12000  
Date Installed: 01/01/1977  
Substance: Kerosene  
Reported Release: Not reported  
Close Type: Closed  
Date Removed: 09/01/1994  
Close Type: 09/01/1994  
Tank Material: Asphalt Coated or Bare Steel  
2nd Containmnt: None

Map ID  
Direction  
Distance  
Elevation

MAP FINDINGS

Site

Database(s)

EDR ID Number  
EPA ID Number

**BST GULFPORT CO 77104 (Continued)**

**U003009992**

Tank Lead Detection: Deferred  
Overfill Protection: No  
Spill Prevention: No

Pipe:

Tank No: 1  
Tank Id: 23471  
Pipe Id: 1  
Pipe Status: Permanently Out of Use  
Type Of Closure: Closed  
Pipe Material Construction: Coated/Wrapped Steel  
Secondary Pipe Material: Cathodically Protected  
Piping Type: U.S. Suction  
Pipe Leak Detection: Deferred

Tank:

Tank No: 2  
Tank ID: 23472  
**Tank Status: Currently In Use**  
Tank Capacity: 10000  
Date Installed: 09/01/1994  
Substance: Diesel  
Reported Release: Not reported  
Close Type: Not reported  
Date Removed: Not reported  
Close Type: Not reported  
Tank Material: Fiberglass Reinforced Plastic  
2nd Containmnt: None  
Tank Lead Detection: Deferred  
Overfill Protection: Yes  
Spill Prevention: Yes

Pipe:

Tank No: 2  
Tank Id: 23472  
Pipe Id: 2  
Pipe Status: Currently In Use  
Type Of Closure: Not reported  
Pipe Material Construction: Other  
Secondary Pipe Material: Double-Walled  
Piping Type: U.S. Suction  
Pipe Leak Detection: Deferred

155  
NNE  
1/2-1  
0.661 mi.  
3488 ft.

**MCMURTRY'S AUTO MACHINE SHOP**  
**1908 25TH AVENUE**  
**GULFPORT, MS 39501**

**RCRA-CESQG 1004743665**  
**MSR000001222**

**Relative:**  
**Higher**

RCRA-CESQG:  
Date form received by agency: 08/28/1995  
Facility name: MCMURTRY'S AUTO MACHINE SHOP  
Facility address: 1908 25TH AVENUE  
GULFPORT, MS 395014514  
EPA ID: MSR000001222

**Actual:**  
**26 ft.**

Map ID  
Direction  
Distance  
Elevation

MAP FINDINGS

Site

Database(s)

EDR ID Number  
EPA ID Number

**MCMURTRY'S AUTO MACHINE SHOP (Continued)**

**1004743665**

Mailing address: 25TH AVENUE  
GULFPORT, MS 395014514

Contact: DAVID MCMURTRY  
Contact address: 1908 25TH AVENUE  
GULFPORT, MS 395014514

Contact country: US  
Contact telephone: (601) 863-4139  
Contact email: Not reported  
EPA Region: 04  
Classification: Conditionally Exempt Small Quantity Generator  
Description: Handler: generates 100 kg or less of hazardous waste per calendar month, and accumulates 1000 kg or less of hazardous waste at any time; or generates 1 kg or less of acutely hazardous waste per calendar month, and accumulates at any time: 1 kg or less of acutely hazardous waste; or 100 kg or less of any residue or contaminated soil, waste or other debris resulting from the cleanup of a spill, into or on any land or water, of acutely hazardous waste; or generates 100 kg or less of any residue or contaminated soil, waste or other debris resulting from the cleanup of a spill, into or on any land or water, of acutely hazardous waste during any calendar month, and accumulates at any time: 1 kg or less of acutely hazardous waste; or 100 kg or less of any residue or contaminated soil, waste or other debris resulting from the cleanup of a spill, into or on any land or water, of acutely hazardous waste

Owner/Operator Summary:

Owner/operator name: DAVID MCMURTRY  
Owner/operator address: 1908 25TH AVENUE  
GULFPORT, MS 39501

Owner/operator country: Not reported  
Owner/operator telephone: (601) 863-4139  
Legal status: Private  
Owner/Operator Type: Owner  
Owner/Op start date: Not reported  
Owner/Op end date: Not reported

Handler Activities Summary:

U.S. importer of hazardous waste: No  
Mixed waste (haz. and radioactive): No  
Recycler of hazardous waste: No  
Transporter of hazardous waste: No  
Treater, storer or disposer of HW: No  
Underground injection activity: No  
On-site burner exemption: No  
Furnace exemption: No  
Used oil fuel burner: No  
Used oil processor: No  
Used oil refiner: No  
Used oil fuel marketer to burner: No  
Used oil Specification marketer: No  
Used oil transfer facility: No  
Used oil transporter: No

. Waste code: D001  
. Waste name: IGNITABLE WASTE



Map ID  
Direction  
Distance  
Elevation

MAP FINDINGS

Site

Database(s)

EDR ID Number  
EPA ID Number

**MCMURTRY'S AUTO MACHINE SHOP (Continued)**

1004743665

Violation Status: No violations found

**AB156** **WARFIELDS AUTO BODY SHOP**  
**NNW** **1814 33RD AVENUE**  
**1/2-1** **GULFPORT, MS 39501**  
**0.666 mi.**  
**3515 ft.** **Site 1 of 2 in cluster AB**

**RCRA-CESQG** **1004742853**  
**MSD982161754**

**Relative:**  
**Higher**

RCRA-CESQG:

Date form received by agency: 03/23/1988

Facility name: WARFIELDS AUTO BODY SHOP

Facility address: 1814 33RD AVENUE  
GULFPORT, MS 39501

EPA ID: MSD982161754

Mailing address: 33RD AVENUE  
GULFPORT, MS 39501

Contact: LEE WARFIELD

Contact address: 1814 33RD AVENUE  
GULFPORT, MS 39501

Contact country: US

Contact telephone: (601) 863-7211

Contact email: Not reported

EPA Region: 04

Classification: Conditionally Exempt Small Quantity Generator

Description: Handler: generates 100 kg or less of hazardous waste per calendar month, and accumulates 1000 kg or less of hazardous waste at any time; or generates 1 kg or less of acutely hazardous waste per calendar month, and accumulates at any time: 1 kg or less of acutely hazardous waste; or 100 kg or less of any residue or contaminated soil, waste or other debris resulting from the cleanup of a spill, into or on any land or water, of acutely hazardous waste; or generates 100 kg or less of any residue or contaminated soil, waste or other debris resulting from the cleanup of a spill, into or on any land or water, of acutely hazardous waste during any calendar month, and accumulates at any time: 1 kg or less of acutely hazardous waste; or 100 kg or less of any residue or contaminated soil, waste or other debris resulting from the cleanup of a spill, into or on any land or water, of acutely hazardous waste

Owner/Operator Summary:

Owner/operator name: WARFIELD AUTO BODY SHOP

Owner/operator address: 1814 33RD AVENUE  
GULFPORT, MS 39501

Owner/operator country: Not reported

Owner/operator telephone: (601) 863-7211

Legal status: Private

Owner/Operator Type: Owner

Owner/Op start date: Not reported

Owner/Op end date: Not reported

Handler Activities Summary:

U.S. importer of hazardous waste: No

Mixed waste (haz. and radioactive): No

Recycler of hazardous waste: No

Transporter of hazardous waste: No

Treater, storer or disposer of HW: No

Underground injection activity: No

On-site burner exemption: No

Map ID  
Direction  
Distance  
Elevation

MAP FINDINGS

Site

Database(s)

EDR ID Number  
EPA ID Number

**WARFIELDS AUTO BODY SHOP (Continued)**

**1004742853**

Furnace exemption: No  
Used oil fuel burner: No  
Used oil processor: No  
User oil refiner: No  
Used oil fuel marketer to burner: No  
Used oil Specification marketer: No  
Used oil transfer facility: No  
Used oil transporter: No

. Waste code: D001  
. Waste name: IGNITABLE WASTE

. Waste code: F001  
. Waste name: THE FOLLOWING SPENT HALOGENATED SOLVENTS USED IN DEGREASING: TETRACHLOROETHYLENE, TRICHLOROETHYLENE, METHYLENE CHLORIDE, 1,1,1-TRICHLOROETHANE, CARBON TETRACHLORIDE AND CHLORINATED FLUOROCARBONS; ALL SPENT SOLVENT MIXTURES/BLENDS USED IN DEGREASING CONTAINING, BEFORE USE, A TOTAL OF TEN PERCENT OR MORE (BY VOLUME) OF ONE OR MORE OF THE ABOVE HALOGENATED SOLVENTS OR THOSE SOLVENTS LISTED IN F002, F004, AND F005; AND STILL BOTTOMS FROM THE RECOVERY OF THESE SPENT SOLVENTS AND SPENT SOLVENT MIXTURES.

. Waste code: F002  
. Waste name: THE FOLLOWING SPENT HALOGENATED SOLVENTS: TETRACHLOROETHYLENE, METHYLENE CHLORIDE, TRICHLOROETHYLENE, 1,1,1-TRICHLOROETHANE, CHLOROBENZENE, 1,1,2-TRICHLORO-1,2,2-TRIFLUOROETHANE, ORTHO-DICHLOROBENZENE, TRICHLOROFLUOROMETHANE, AND 1,1,2, TRICHLOROETHANE; ALL SPENT SOLVENT MIXTURES/BLENDS CONTAINING, BEFORE USE, A TOTAL OF TEN PERCENT OR MORE (BY VOLUME) OF ONE OR MORE OF THE ABOVE HALOGENATED SOLVENTS OR THOSE SOLVENTS LISTED IN F001, F004, AND F005; AND STILL BOTTOMS FROM THE RECOVERY OF THESE SPENT SOLVENTS AND SPENT SOLVENT MIXTURES.

. Waste code: F003  
. Waste name: THE FOLLOWING SPENT NONHALOGENATED SOLVENTS: XYLENE, ACETONE, ETHYL ACETATE, ETHYL BENZENE, ETHYL ETHER, METHYL ISOBUTYL KETONE, N-BUTYL ALCOHOL, CYCLOHEXANONE, AND METHANOL; ALL SPENT SOLVENT MIXTURES/BLENDS CONTAINING, BEFORE USE, ONLY THE ABOVE SPENT NONHALOGENATED SOLVENTS; AND ALL SPENT SOLVENT MIXTURES/BLENDS CONTAINING, BEFORE USE, ONE OR MORE OF THE ABOVE NONHALOGENATED SOLVENTS, AND A TOTAL OF TEN PERCENT OR MORE (BY VOLUME) OF ONE OR MORE OF THOSE SOLVENTS LISTED IN F001, F002, F004, AND F005; AND STILL BOTTOMS FROM THE RECOVERY OF THESE SPENT SOLVENTS AND SPENT SOLVENT MIXTURES.

. Waste code: F005  
. Waste name: THE FOLLOWING SPENT NONHALOGENATED SOLVENTS: TOLUENE, METHYL ETHYL KETONE, CARBON DISULFIDE, ISOBUTANOL, PYRIDINE, BENZENE, 2-ETHOXYETHANOL, AND 2-NITROPROPANE; ALL SPENT SOLVENT MIXTURES/BLENDS CONTAINING, BEFORE USE, A TOTAL OF TEN PERCENT OR MORE (BY VOLUME) OF ONE OR MORE OF THE ABOVE NONHALOGENATED SOLVENTS OR THOSE SOLVENTS LISTED IN F001, F002, OR F004; AND STILL BOTTOMS FROM THE RECOVERY OF THESE SPENT SOLVENTS AND SPENT SOLVENT MIXTURES.

Violation Status: No violations found

Map ID  
Direction  
Distance  
Elevation

MAP FINDINGS

Site

Database(s)

EDR ID Number  
EPA ID Number

**AB157**  
**NNW**  
**1/2-1**  
**0.666 mi.**  
**3515 ft.**

**1814 33RD AVE**  
**GULFPORT, MS 39501**

**EDR US Hist Auto Stat**    **1015280601**  
**N/A**

**Site 2 of 2 in cluster AB**

**Relative:**  
**Higher**

EDR Historical Auto Stations:

**Actual:**  
**26 ft.**

Name: WARFIELD AUTO BODY SHOP INCORPORATED SINCE 1942  
Year: 1999  
Address: 1814 33RD AVE

Name: WARFIELD AUTO BODY SHOP INCORPORATED SINCE 1942  
Year: 2000  
Address: 1814 33RD AVE

Name: WARFIELD AUTO BODY SHOP INC  
Year: 2001  
Address: 1814 33RD AVE

Name: WARFIELD AUTO BODY SHOP INC  
Year: 2002  
Address: 1814 33RD AVE

Name: WARFIELD AUTO BODY SHOP INC  
Year: 2003  
Address: 1814 33RD AVE

Name: WARFIELD AUTO BODY SHOP INC  
Year: 2005  
Address: 1814 33RD AVE

Name: WARFIELD AUTO BODY SHOP INC  
Year: 2006  
Address: 1814 33RD AVE

Name: WARFIELD AUTO BODY SHOP INC  
Year: 2007  
Address: 1814 33RD AVE

Name: WARFIELD AUTO BODY SHOP INC  
Year: 2008  
Address: 1814 33RD AVE

Name: WARFIELD AUTO BODY SHOP INC  
Year: 2009  
Address: 1814 33RD AVE

Name: WARFIELD AUTO BODY SHOP INC  
Year: 2010  
Address: 1814 33RD AVE

Name: WARFIELD AUTO BODY SHOP INC  
Year: 2011  
Address: 1814 33RD AVE

Name: WARFIELD AUTO BODY SHOP  
Year: 2012  
Address: 1814 33RD AVE

Map ID  
Direction  
Distance  
Elevation

MAP FINDINGS

Site

Database(s)

EDR ID Number  
EPA ID Number

AC158  
NNE  
1/2-1  
0.672 mi.  
3550 ft.

**PETE'S ELECTRIC SERVICE, INC.**  
**2420 19TH STREET**  
**GULFPORT, MS 39501**  
**Site 1 of 3 in cluster AC**

**RCRA-CESQG 1004743513**  
**MSD985981323**

**Relative:  
Higher**

RCRA-CESQG:

Date form received by agency: 06/28/1993  
Facility name: PETE'S ELECTRIC SERVICE, INC.

**Actual:  
26 ft.**

Facility address: 2420 19TH STREET  
GULFPORT, MS 39501

EPA ID: MSD985981323

Mailing address: 19TH STREET  
GULFPORT, MS 39501

Contact: PETER UMBDENSTOCK

Contact address: 2420 19TH STREET  
GULFPORT, MS 39501

Contact country: US

Contact telephone: (601) 863-5672

Contact email: Not reported

EPA Region: 04

Classification: Conditionally Exempt Small Quantity Generator

Description: Handler: generates 100 kg or less of hazardous waste per calendar month, and accumulates 1000 kg or less of hazardous waste at any time; or generates 1 kg or less of acutely hazardous waste per calendar month, and accumulates at any time: 1 kg or less of acutely hazardous waste; or 100 kg or less of any residue or contaminated soil, waste or other debris resulting from the cleanup of a spill, into or on any land or water, of acutely hazardous waste; or generates 100 kg or less of any residue or contaminated soil, waste or other debris resulting from the cleanup of a spill, into or on any land or water, of acutely hazardous waste during any calendar month, and accumulates at any time: 1 kg or less of acutely hazardous waste; or 100 kg or less of any residue or contaminated soil, waste or other debris resulting from the cleanup of a spill, into or on any land or water, of acutely hazardous waste

Owner/Operator Summary:

Owner/operator name: PETER UMBDENSTOCK  
Owner/operator address: 2420 19TH STREET  
GULFPORT, MS 39501

Owner/operator country: Not reported

Owner/operator telephone: (601) 863-5672

Legal status: Private

Owner/Operator Type: Owner

Owner/Op start date: Not reported

Owner/Op end date: Not reported

Handler Activities Summary:

U.S. importer of hazardous waste: No

Mixed waste (haz. and radioactive): No

Recycler of hazardous waste: No

Transporter of hazardous waste: No

Treater, storer or disposer of HW: No

Underground injection activity: No

On-site burner exemption: No

Furnace exemption: No

Used oil fuel burner: No

Map ID  
Direction  
Distance  
Elevation

MAP FINDINGS

Site

Database(s)

EDR ID Number  
EPA ID Number

**PETE'S ELECTRIC SERVICE, INC. (Continued)**

**1004743513**

Used oil processor: No  
User oil refiner: No  
Used oil fuel marketer to burner: No  
Used oil Specification marketer: No  
Used oil transfer facility: No  
Used oil transporter: No

. Waste code: D001  
. Waste name: IGNITABLE WASTE

. Waste code: D018  
. Waste name: BENZENE

. Waste code: D039  
. Waste name: TETRACHLOROETHYLENE

Violation Status: No violations found

**AC159**  
**NNE**  
**1/2-1**  
**0.674 mi.**  
**3560 ft.**

**2407 19TH ST**  
**GULFPORT, MS 39501**  
**Site 2 of 3 in cluster AC**

**EDR US Hist Auto Stat 1015354948**  
**N/A**

**Relative:**  
**Higher**

EDR Historical Auto Stations:  
Name: RAYNER ENGINE REBUILDERS INC  
Year: 2002  
Address: 2407 19TH ST

**Actual:**  
**26 ft.**

**AC160**  
**NNE**  
**1/2-1**  
**0.674 mi.**  
**3560 ft.**

**KENNY YOUNG'S ENGINE REBUILDING**  
**2407 19TH STREET**  
**GULFPORT, MS 39501**  
**Site 3 of 3 in cluster AC**

**RCRA-CESQG 1004742455**  
**MS0000644195**

**Relative:**  
**Higher**

RCRA-CESQG:  
Date form received by agency: 09/01/1994  
Facility name: KENNY YOUNG'S ENGINE REBUILDING  
Facility address: 2407 19TH STREET  
GULFPORT, MS 39501  
EPA ID: MS0000644195  
Mailing address: 19TH STREET  
GULFPORT, MS 39501  
Contact: KENNETH YOUNG  
Contact address: 2407 19TH STREET  
GULFPORT, MS 39501  
Contact country: US  
Contact telephone: (601) 868-8728  
Contact email: Not reported  
EPA Region: 04  
Classification: Conditionally Exempt Small Quantity Generator  
Description: Handler: generates 100 kg or less of hazardous waste per calendar month, and accumulates 1000 kg or less of hazardous waste at any time; or generates 1 kg or less of acutely hazardous waste per calendar month, and accumulates at any time: 1 kg or less of acutely hazardous waste; or 100 kg or less of any residue or contaminated soil, waste or other debris resulting from the cleanup of a spill, into or on any

**Actual:**  
**26 ft.**

Map ID  
Direction  
Distance  
Elevation

MAP FINDINGS

Site

Database(s)

EDR ID Number  
EPA ID Number

**KENNY YOUNG'S ENGINE REBUILDING (Continued)**

**1004742455**

land or water, of acutely hazardous waste; or generates 100 kg or less of any residue or contaminated soil, waste or other debris resulting from the cleanup of a spill, into or on any land or water, of acutely hazardous waste during any calendar month, and accumulates at any time: 1 kg or less of acutely hazardous waste; or 100 kg or less of any residue or contaminated soil, waste or other debris resulting from the cleanup of a spill, into or on any land or water, of acutely hazardous waste

Owner/Operator Summary:

Owner/operator name: KENNETH W. YOUNG  
Owner/operator address: 2407 19TH STREET  
GULFPORT, MS 39501  
Owner/operator country: Not reported  
Owner/operator telephone: (601) 868-8728  
Legal status: Private  
Owner/Operator Type: Owner  
Owner/Op start date: Not reported  
Owner/Op end date: Not reported

Handler Activities Summary:

U.S. importer of hazardous waste: No  
Mixed waste (haz. and radioactive): No  
Recycler of hazardous waste: No  
Transporter of hazardous waste: No  
Treater, storer or disposer of HW: No  
Underground injection activity: No  
On-site burner exemption: No  
Furnace exemption: No  
Used oil fuel burner: No  
Used oil processor: No  
User oil refiner: No  
Used oil fuel marketer to burner: No  
Used oil Specification marketer: No  
Used oil transfer facility: No  
Used oil transporter: No

. Waste code: D001  
. Waste name: IGNITABLE WASTE

Violation Status: No violations found

AA161  
North  
1/2-1  
0.681 mi.  
3594 ft.

**MDOT - GULFPORT SERVICE CENTER**  
**GULFPORT, MS**  
**Site 4 of 4 in cluster AA**

**SHWS S108634336**  
**N/A**

Relative:  
Higher

SHWS:  
Lat/Long (dms): 30 22 27 / 89 5 47  
Site Size (acres): Not reported  
EPA ID: Not reported  
Project Manager: Not reported  
**Status: SNFA**  
State No Further Action Date: 07/19/2001  
Federal: Not reported  
Federal No Further Action Date: Not reported  
Soil Contamination: No

Actual:  
28 ft.

Map ID  
Direction  
Distance  
Elevation

MAP FINDINGS

Site

Database(s)

EDR ID Number  
EPA ID Number

**MDOT - GULFPORT SERVICE CENTER (Continued)**

**S108634336**

Surface Water Contamination: No  
Ground Water Contamination: No  
Remediation Type: Not reported  
Surface Water Remediation: Not reported  
GW Remediation Type: Not reported  
Maj. Contaminant: Not reported  
High Concentration: Not reported  
High Concentration Units: Not reported  
Institutional Control: Not reported  
Engineering Control: Not reported  
Voluntary Cleanups: Not reported

**AD162**  
**West**  
**1/2-1**  
**0.700 mi.**  
**3698 ft.**

**3820 W RAILROAD ST**  
**GULFPORT, MS 39501**

**EDR US Hist Auto Stat 1015459810**  
**N/A**

**Site 1 of 3 in cluster AD**

**Relative:**  
**Higher**

EDR Historical Auto Stations:

**Actual:**  
**26 ft.**

Name: RONNIES AUTOMOTIVE  
Year: 2001  
Address: 3820 W RAILROAD ST

Name: RONNIES AUTOMOTIVE  
Year: 2002  
Address: 3820 W RAILROAD ST

Name: RONNIES AUTO & TIRE SERVICE  
Year: 2003  
Address: 3820 W RAILROAD ST

Name: RONNIES AUTOMOTIVE  
Year: 2004  
Address: 3820 W RAILROAD ST

Name: RONNIES AUTOMOTIVE & TOWING SERVICE  
Year: 2005  
Address: 3820 W RAILROAD ST

Name: RONNIES AUTOMOTIVE INC  
Year: 2006  
Address: 3820 W RAILROAD ST

Name: RONNIES AUTOMOTIVE & TOWING SERVICE  
Year: 2007  
Address: 3820 W RAILROAD ST

Name: RONNIES AUTOMOTIVE & TOWING SERVICE  
Year: 2009  
Address: 3820 W RAILROAD ST

Name: RONNIES AUTOMOTIVE & TOWING  
Year: 2010  
Address: 3820 W RAILROAD ST

MAP FINDINGS

Map ID  
Direction  
Distance  
Elevation

Site

Database(s)

EDR ID Number  
EPA ID Number

**AD163**      **RONNY'S AUTOMOTIVE**  
**West**        **3820 WEST RAILROAD STREET**  
**1/2-1**        **GULFPORT, MS 39501**  
**0.700 mi.**  
**3698 ft.**      **Site 2 of 3 in cluster AD**

**UST**    **1000476145**  
**N/A**

**Relative:**  
**Higher**

UST:  
 Facility ID:                    9622  
 Facility Status:                Inactive  
 Latitude:                        30 21' 55.6000"  
 Longitude:                       89 6' 28.8000"  
 Permanently Out of Use Tanks: 2  
 Active Tanks:                   0  
 AIID:                             4049  
 Owner Name:                    Ronald McKenna  
 Owner Address:                3820 West Railroad Street  
 Owner Tele:                    (228)864-3715

**Actual:**  
**26 ft.**

Tank:  
 Tank No:                         1  
 Tank ID:                         24260  
**Tank Status:                    Permanently Out of Use**  
 Tank Capacity:                 4000  
 Date Installed:                 01/01/1986  
 Substance:                       Gasoline  
 Reported Release:               Not reported  
 Close Type:                      Not reported  
 Date Removed:                 04/02/2005  
 Close Type:                      Not reported  
 Tank Material:                 Epoxy Coated Steel  
 2nd Containmnt:                Cathodically Protected  
 Tank Lead Detection:           Groundwater/Vapor Monitoring  
 Overfill Protection:            Yes  
 Spill Prevention:               Yes

Pipe:  
 Tank No:                         1  
 Tank Id:                         24260  
 Pipe Id:                         1  
 Pipe Status:                      Permanently Out of Use  
 Type Of Closure:                Not reported  
 Pipe Material Construction:   Coated/Wrapped Steel  
 Secondary Pipe Material:      Cathodically Protected  
 Piping Type:                     Pressurized  
 Pipe Leak Detection:            Groundwater/Vapor Monitoring

Tank:  
 Tank No:                         2  
 Tank ID:                         24261  
**Tank Status:                    Permanently Out of Use**  
 Tank Capacity:                 4000  
 Date Installed:                 01/01/1986  
 Substance:                       Gasoline  
 Reported Release:               Not reported  
 Close Type:                      Not reported  
 Date Removed:                 04/02/2005  
 Close Type:                      Not reported



Map ID  
Direction  
Distance  
Elevation

MAP FINDINGS

Site

Database(s)

EDR ID Number  
EPA ID Number

**RONNY'S AUTOMOTIVE (Continued)**

**1000476145**

Tank Material: Epoxy Coated Steel  
2nd Containmnt: Cathodically Protected  
Tank Lead Detection: Groundwater/Vapor Monitoring  
Overfill Protection: Yes  
Spill Prevention: Yes

Pipe:

Tank No: 2  
Tank Id: 24261  
Pipe Id: 2  
Pipe Status: Permanently Out of Use  
Type Of Closure: Not reported  
Pipe Material Construction: Coated/Wrapped Steel  
Secondary Pipe Material: Cathodically Protected  
Piping Type: Pressurized  
Pipe Leak Detection: Groundwater/Vapor Monitoring

**AD164**  
**West**  
**1/2-1**  
**0.700 mi.**  
**3698 ft.**

**RONNIES AUTOMOTIVE**  
**3820 WEST RAILROAD**  
**GULFPORT, MS 39501**  
**Site 3 of 3 in cluster AD**

**RCRA-CESQG 1004743081**  
**MSD985969377**

**Relative:**  
**Higher**

RCRA-CESQG:

**Actual:**  
**26 ft.**

Date form received by agency: 05/26/1992  
Facility name: RONNIES AUTOMOTIVE  
Facility address: 3820 WEST RAILROAD  
GULFPORT, MS 395013820  
EPA ID: MSD985969377  
Mailing address: WEST RAILROAD  
GULFPORT, MS 395013820  
Contact: PHYLLIS MCKENNA  
Contact address: 3820 WEST RAILROAD  
GULFPORT, MS 395013820  
Contact country: US  
Contact telephone: (601) 864-3715  
Contact email: Not reported  
EPA Region: 04  
Classification: Conditionally Exempt Small Quantity Generator  
Description: Handler: generates 100 kg or less of hazardous waste per calendar month, and accumulates 1000 kg or less of hazardous waste at any time; or generates 1 kg or less of acutely hazardous waste per calendar month, and accumulates at any time: 1 kg or less of acutely hazardous waste; or 100 kg or less of any residue or contaminated soil, waste or other debris resulting from the cleanup of a spill, into or on any land or water, of acutely hazardous waste; or generates 100 kg or less of any residue or contaminated soil, waste or other debris resulting from the cleanup of a spill, into or on any land or water, of acutely hazardous waste during any calendar month, and accumulates at any time: 1 kg or less of acutely hazardous waste; or 100 kg or less of any residue or contaminated soil, waste or other debris resulting from the cleanup of a spill, into or on any land or water, of acutely hazardous waste

Owner/Operator Summary:

Owner/operator name: RONNIE'S AUTOMOTIVE  
Owner/operator address: 3820 W RAILROAD

Map ID  
Direction  
Distance  
Elevation

MAP FINDINGS

Site

Database(s)

EDR ID Number  
EPA ID Number

**RONNIES AUTOMOTIVE (Continued)**

**1004743081**

GULFPORT, MS 39501  
Owner/operator country: Not reported  
Owner/operator telephone: (601) 864-3715  
Legal status: Private  
Owner/Operator Type: Owner  
Owner/Op start date: Not reported  
Owner/Op end date: Not reported

Handler Activities Summary:

U.S. importer of hazardous waste: No  
Mixed waste (haz. and radioactive): No  
Recycler of hazardous waste: No  
Transporter of hazardous waste: No  
Treater, storer or disposer of HW: No  
Underground injection activity: No  
On-site burner exemption: No  
Furnace exemption: No  
Used oil fuel burner: No  
Used oil processor: No  
User oil refiner: No  
Used oil fuel marketer to burner: No  
Used oil Specification marketer: No  
Used oil transfer facility: No  
Used oil transporter: No

. Waste code: D001  
. Waste name: IGNITABLE WASTE

. Waste code: F001  
. Waste name: THE FOLLOWING SPENT HALOGENATED SOLVENTS USED IN DEGREASING: TETRACHLOROETHYLENE, TRICHLORETHYLENE, METHYLENE CHLORIDE, 1,1,1-TRICHLOROETHANE, CARBON TETRACHLORIDE AND CHLORINATED FLUOROCARBONS; ALL SPENT SOLVENT MIXTURES/BLENDS USED IN DEGREASING CONTAINING, BEFORE USE, A TOTAL OF TEN PERCENT OR MORE (BY VOLUME) OF ONE OR MORE OF THE ABOVE HALOGENATED SOLVENTS OR THOSE SOLVENTS LISTED IN F002, F004, AND F005; AND STILL BOTTOMS FROM THE RECOVERY OF THESE SPENT SOLVENTS AND SPENT SOLVENT MIXTURES.

Violation Status: No violations found

165  
North  
1/2-1  
0.724 mi.  
3822 ft.

2005 30TH AVE  
GULFPORT, MS 39501

EDR US Hist Cleaners 1015012939  
N/A

Relative:  
Higher

EDR Historical Cleaners:

Name: MIRACLE DRY CLEANERS & LAUNDRY  
Year: 2001  
Address: 2005 30TH AVE

Name: MIRACLE DRY CLEANERS & LAUNDRY  
Year: 2003  
Address: 2005 30TH AVE

Name: MIRACLE DRY CLNR & LNDRY JOS  
Year: 2004  
Address: 2005 30TH AVE

Actual:  
29 ft.

Map ID  
Direction  
Distance  
Elevation

MAP FINDINGS

Site

Database(s)

EDR ID Number  
EPA ID Number

166  
NNE  
1/2-1  
0.724 mi.  
3824 ft.

**THERMO-KING**  
**2510 20TH ST**  
**GULFPORT, MS 39501**

**RCRA-CESQG 1004743782**  
**MSR000002733**

**Relative:**  
**Higher**

RCRA-CESQG:

**Actual:**  
**29 ft.**

Date form received by agency: 04/30/1996  
Facility name: THERMO-KING  
Facility address: 2510 20TH ST  
GULFPORT, MS 39501  
EPA ID: MSR000002733  
Mailing address: 20TH ST  
GULFPORT, MS 39501  
Contact: RICKY MITCHELL  
Contact address: 2510 20TH ST  
GULFPORT, MS 39501  
Contact country: US  
Contact telephone: (601) 863-7399  
Contact email: Not reported  
EPA Region: 04  
Classification: Conditionally Exempt Small Quantity Generator  
Description: Handler: generates 100 kg or less of hazardous waste per calendar month, and accumulates 1000 kg or less of hazardous waste at any time; or generates 1 kg or less of acutely hazardous waste per calendar month, and accumulates at any time: 1 kg or less of acutely hazardous waste; or 100 kg or less of any residue or contaminated soil, waste or other debris resulting from the cleanup of a spill, into or on any land or water, of acutely hazardous waste; or generates 100 kg or less of any residue or contaminated soil, waste or other debris resulting from the cleanup of a spill, into or on any land or water, of acutely hazardous waste during any calendar month, and accumulates at any time: 1 kg or less of acutely hazardous waste; or 100 kg or less of any residue or contaminated soil, waste or other debris resulting from the cleanup of a spill, into or on any land or water, of acutely hazardous waste

Owner/Operator Summary:

Owner/operator name: CLARENCE MCBRIDE JR.  
Owner/operator address: 2510 20TH STREET  
GULFPORT, MS 39501  
Owner/operator country: Not reported  
Owner/operator telephone: (601) 863-7399  
Legal status: Private  
Owner/Operator Type: Owner  
Owner/Op start date: Not reported  
Owner/Op end date: Not reported

Handler Activities Summary:

U.S. importer of hazardous waste: No  
Mixed waste (haz. and radioactive): No  
Recycler of hazardous waste: No  
Transporter of hazardous waste: No  
Treater, storer or disposer of HW: No  
Underground injection activity: No  
On-site burner exemption: No  
Furnace exemption: No  
Used oil fuel burner: No

Map ID  
Direction  
Distance  
Elevation

MAP FINDINGS

Site

Database(s)

EDR ID Number  
EPA ID Number

**THERMO-KING (Continued)**

**1004743782**

Used oil processor: No  
User oil refiner: No  
Used oil fuel marketer to burner: No  
Used oil Specification marketer: No  
Used oil transfer facility: No  
Used oil transporter: No  
  
. Waste code: D001  
. Waste name: IGNITABLE WASTE  
  
Violation Status: No violations found

167  
NNW  
1/2-1  
0.743 mi.  
3922 ft.

**3109 20TH ST  
GULFPORT, MS 39501**

**EDR US Hist Cleaners 1015040352  
N/A**

**Relative:  
Higher**  
  
**Actual:  
26 ft.**

EDR Historical Cleaners:  
Name: NEIGHBORHOOD LAUNDRY  
Year: 1999  
Address: 3109 20TH ST  
  
Name: NEIGHBORHOOD LAUNDRY  
Year: 2000  
Address: 3109 20TH ST  
  
Name: NEIGHBORHOOD LAUNDRY  
Year: 2001  
Address: 3109 20TH ST  
  
Name: NEIGHBORHOOD LAUNDRY  
Year: 2002  
Address: 3109 20TH ST  
  
Name: NEIGHBORHOOD LAUNDRY  
Year: 2003  
Address: 3109 20TH ST  
  
Name: NEIGHBORHOOD LAUNDRY  
Year: 2004  
Address: 3109 20TH ST  
  
Name: NEIGHBORHOOD LAUNDRY  
Year: 2005  
Address: 3109 20TH ST  
  
Name: NEIGHBORHOOD LAUNDRY  
Year: 2006  
Address: 3109 20TH ST  
  
Name: NEIGHBORHOOD LAUNDRY  
Year: 2007  
Address: 3109 20TH ST  
  
Name: NEIGHBORHOOD LAUNDRY  
Year: 2008  
Address: 3109 20TH ST

Map ID  
Direction  
Distance  
Elevation

MAP FINDINGS

Site

Database(s)

EDR ID Number  
EPA ID Number

(Continued)

1015040352

Name: NEIGHBORHOOD LAUNDRY  
Year: 2009  
Address: 3109 20TH ST

Name: NEIGHBORHOOD LAUNDRY  
Year: 2010  
Address: 3109 20TH ST

Name: NEIGHBORHOOD LAUNDRY  
Year: 2011  
Address: 3109 20TH ST

Name: NEIGHBORHOOD LAUNDRY  
Year: 2012  
Address: 3109 20TH ST

168  
NNE  
1/2-1  
0.745 mi.  
3931 ft.

2415 20TH ST  
GULFPORT, MS 39501

EDR US Hist Cleaners 1015026097  
N/A

Relative:  
Higher

EDR Historical Cleaners:

Name: THE LAUNDROMAT  
Year: 2009  
Address: 2415 20TH ST

Name: LAUNDROMAT  
Year: 2010  
Address: 2415 20TH ST

Name: THE LAUNDROMAT  
Year: 2011  
Address: 2415 20TH ST

Name: THE LAUNDROMAT  
Year: 2012  
Address: 2415 20TH ST

Actual:  
28 ft.

AE169  
NNE  
1/2-1  
0.812 mi.  
4287 ft.

2120 25TH AV  
2120 25TH AV  
GULFPORT, MS 39506

US BROWNFIELDS 1016159031  
N/A

Site 1 of 2 in cluster AE

Relative:  
Higher

US BROWNFIELDS:

Recipient name: Gulfport, City of  
Grant type: Assessment  
Property name: 2120 25TH AV  
Property #: 0811F-05-054.00  
Parcel size: .18

Actual:  
30 ft.

Property Description:

At the time of the site reconnaissance performed on July 10, 2012, the property was in use as two unoccupied office suites (Suite A and Suite B) and two commercially occupied office suites (Suite C and Suite D). The property is owned by Mr. Glenn Miller. Mr. Miller indicated that the original portions of the existing building were

Map ID  
Direction  
Distance  
Elevation

MAP FINDINGS

Site

Database(s)

EDR ID Number  
EPA ID Number

2120 25TH AV (Continued)

1016159031

first constructed in 1922. When Mr. Miller purchased the property in 2005, the building was occupied by Showgirls Lingerie. In 2006, Mr. Miller indicated that the property was completely remodeled in order to comply with building codes at that time. From 2006 through 2008 the building was occupied by Blue Cliff College, and from 2008 to present the property has been leased to various tenants for office space, according to Mr. Miller. A review of city directories depicts the property as historically being commercially occupied. Con Survey City Directory lists the property as an insurance company in 1962 and 1968. Polks City Directory lists the property as an auto parts store in 1978, an antique shop in 1984, Showgirls Lingerie in 2002, Blue Cliff College in 2007, and Beyers Engineering in 2012. In 1973 the property was listed as vacant, and in 1990 and 1997 it was not listed in the Polks City Directories. The historical use of the property for automotive service, and the former presence of a gasoline underground storage tank and solvent tank represent a recognized environmental condition.

Latitude: 30.376485  
Longitude: -89.092574  
HCM label: Address Matching-House Number  
Map scale: Not reported  
Point of reference: Entrance Point of a Facility or Station  
Datum: North American Datum of 1983  
ACRES property ID: 150081  
Start date: Not reported  
Completed date: Not reported  
Acres cleaned up: Not reported  
Cleanup funding: Not reported  
Cleanup funding source: Not reported  
Assessment funding: 16756  
Assessment funding source: US EPA - Brownfields Assessment Cooperative Agreement  
Redevelopment funding: 150000  
Redev. funding source: Private/Other Funding  
Redev. funding entity name: Private Bank  
Redevelopment start date: 05/17/2013 00:00:00  
Assessment funding entity: EPA  
Cleanup funding entity: Not reported  
Grant type: B  
Accomplishment type: Phase II Environmental Assessment  
Accomplishment count: 0  
Cooperative agreement #: 95482611  
Ownership entity: Private  
Current owner: Mr. Glenn Miller  
Did owner change: N  
Cleanup required: No  
Video available: No  
Photo available: Yes  
Institutional controls required: N  
IC Category proprietary controls: Not reported  
IC cat. info. devices: Not reported  
IC cat. gov. controls: Not reported  
IC cat. enforcement permit tools: Not reported  
IC in place date: Not reported  
IC in place: No  
State/tribal program date: Not reported  
State/tribal program ID: Not reported  
State/tribal NFA date: 05/17/2013 00:00:00

Map ID  
Direction  
Distance  
Elevation

MAP FINDINGS

Site

Database(s)

EDR ID Number  
EPA ID Number

2120 25TH AV (Continued)

1016159031

Air contaminated:	Not reported
Air cleaned:	Not reported
Asbestos found:	Not reported
Asbestos cleaned:	Not reported
Controlled substance found:	Not reported
Controlled substance cleaned:	Not reported
Drinking water affected:	Not reported
Drinking water cleaned:	Not reported
Groundwater affected:	Not reported
Groundwater cleaned:	Not reported
Lead contaminant found:	Not reported
Lead cleaned up:	Not reported
No media affected:	Not reported
Unknown media affected:	Not reported
Other cleaned up:	Not reported
Other metals found:	Not reported
Other metals cleaned:	Not reported
Other contaminants found:	Not reported
Other contaminants found description:	Not reported
PAHs found:	Not reported
PAHs cleaned up:	Not reported
PCBs found:	Not reported
PCBs cleaned up:	Not reported
Petro products found:	Not reported
Petro products cleaned:	Not reported
Sediments found:	Not reported
Sediments cleaned:	Not reported
Soil affected:	Not reported
Soil cleaned up:	Not reported
Surface water cleaned:	Not reported
VOCs found:	Not reported
VOCs cleaned:	Not reported
Cleanup other description:	Not reported
Num. of cleanup and re-dev. jobs:	0
Past use greenspace acreage:	Not reported
Past use residential acreage:	Not reported
Past use commercial acreage:	.18
Past use industrial acreage:	Not reported
Future use greenspace acreage:	Not reported
Future use residential acreage:	Not reported
Future use commercial acreage:	.18
Future use industrial acreage:	Not reported
Greenspace acreage and type:	Not reported
Superfund Fed. landowner flag:	Not reported
Arsenic cleaned up:	Not reported
Cadmium cleaned up:	Not reported
Chromium cleaned up:	Not reported
Copper cleaned up:	Not reported
Iron cleaned up:	Not reported
mercury cleaned up:	Not reported
nickel cleaned up:	Not reported
No clean up:	Not reported
Pesticides cleaned up:	Not reported
Selenium cleaned up:	Not reported
SVOCs cleaned up:	Not reported
Unknown clean up:	Not reported
Arsenic contaminant found:	Not reported

Map ID  
 Direction  
 Distance  
 Elevation

MAP FINDINGS

Site

Database(s)

EDR ID Number  
 EPA ID Number

**2120 25TH AV (Continued)**

**1016159031**

Cadmium contaminant found:	Not reported
Chromium contaminant found:	Not reported
Copper contaminant found:	Not reported
Iron contaminant found:	Not reported
Mercury contaminant found:	Not reported
Nickel contaminant found:	Not reported
No contaminant found:	Not reported
Pesticides contaminant found:	Not reported
Selenium contaminant found:	Not reported
SVOCs contaminant found:	Not reported
Unknown contaminant found:	Not reported
Future Use: Multistory	Not reported
Media affected Bluiding Material:	Not reported
Media affected indoor air:	Not reported
Building material media cleaned up:	Not reported
Indoor air media cleaned up:	Not reported
Unknown media cleaned up:	Not reported
Past Use: Multistory	Not reported

Recipient name:	Gulfport, City of
Grant type:	Assessment
Property name:	2120 25TH AV
Property #:	0811F-05-054.00
Parcel size:	.18
Property Description:	

At the time of the site reconnaissance performed on July 10, 2012, the property was in use as two unoccupied office suites (Suite A and Suite B) and two commercially occupied office suites (Suite C and Suite D). The property is owned by Mr. Glenn Miller. Mr. Miller indicated that the original portions of the existing building were first constructed in 1922. When Mr. Miller purchased the property in 2005, the building was occupied by Showgirls Lingerie. In 2006, Mr. Miller indicated that the property was completely remodeled in order to comply with building codes at that time. From 2006 through 2008 the building was occupied by Blue Cliff College, and from 2008 to present the property has been leased to various tenants for office space, according to Mr. Miller. A review of city directories depicts the property as historically being commercially occupied. Con Survey City Directory lists the property as an insurance company in 1962 and 1968. Polks City Directory lists the property as an auto parts store in 1978, an antique shop in 1984, Showgirls Lingerie in 2002, Blue Cliff College in 2007, and Beyers Engineering in 2012. In 1973 the property was listed as vacant, and in 1990 and 1997 it was not listed in the Polks City Directories. The historical use of the property for automotive service, and the former presence of a gasoline underground storage tank and solvent tank represent a recognized environmental condition.

Latitude:	30.376485
Longitude:	-89.092574
HCM label:	Address Matching-House Number
Map scale:	Not reported
Point of reference:	Entrance Point of a Facility or Station
Datum:	North American Datum of 1983
ACRES property ID:	150081
Start date:	Not reported
Completed date:	Not reported
Acres cleaned up:	Not reported
Cleanup funding:	Not reported



Map ID  
Direction  
Distance  
Elevation

MAP FINDINGS

Site

Database(s)

EDR ID Number  
EPA ID Number

2120 25TH AV (Continued)

1016159031

Cleanup funding source: Not reported  
Assessment funding: 3485  
Assessment funding source: US EPA - Brownfields Assessment Cooperative Agreement  
Redevelopment funding: 150000  
Redev. funding source: Private/Other Funding  
Redev. funding entity name: Private Bank  
Redevelopment start date: 05/17/2013 00:00:00  
Assessment funding entity: EPA  
Cleanup funding entity: Not reported  
Grant type: B  
Accomplishment type: Phase I Environmental Assessment  
Accomplishment count: 1  
Cooperative agreement #: 95482611  
Ownership entity: Private  
Current owner: Mr. Glenn Miller  
Did owner change: N  
Cleanup required: No  
Video available: No  
Photo available: Yes  
Institutional controls required: N  
IC Category proprietary controls: Not reported  
IC cat. info. devices: Not reported  
IC cat. gov. controls: Not reported  
IC cat. enforcement permit tools: Not reported  
IC in place date: Not reported  
IC in place: No  
State/tribal program date: Not reported  
State/tribal program ID: Not reported  
State/tribal NFA date: 05/17/2013 00:00:00  
Air contaminated: Not reported  
Air cleaned: Not reported  
Asbestos found: Not reported  
Asbestos cleaned: Not reported  
Controlled substance found: Not reported  
Controlled substance cleaned: Not reported  
Drinking water affected: Not reported  
Drinking water cleaned: Not reported  
Groundwater affected: Not reported  
Groundwater cleaned: Not reported  
Lead contaminant found: Not reported  
Lead cleaned up: Not reported  
No media affected: Not reported  
Unknown media affected: Not reported  
Other cleaned up: Not reported  
Other metals found: Not reported  
Other metals cleaned: Not reported  
Other contaminants found: Not reported  
Other contams found description: Not reported  
PAHs found: Not reported  
PAHs cleaned up: Not reported  
PCBs found: Not reported  
PCBs cleaned up: Not reported  
Petro products found: Not reported  
Petro products cleaned: Not reported  
Sediments found: Not reported  
Sediments cleaned: Not reported  
Soil affected: Not reported

Map ID  
Direction  
Distance  
Elevation

MAP FINDINGS

Site

Database(s)

EDR ID Number  
EPA ID Number

**2120 25TH AV (Continued)**

**1016159031**

Soil cleaned up: Not reported  
Surface water cleaned: Not reported  
VOCs found: Not reported  
VOCs cleaned: Not reported  
Cleanup other description: Not reported  
Num. of cleanup and re-dev. jobs: 0  
Past use greenspace acreage: Not reported  
Past use residential acreage: Not reported  
Past use commercial acreage: .18  
Past use industrial acreage: Not reported  
Future use greenspace acreage: Not reported  
Future use residential acreage: Not reported  
Future use commercial acreage: .18  
Future use industrial acreage: Not reported  
Greenspace acreage and type: Not reported  
Superfund Fed. landowner flag: Not reported  
Arsenic cleaned up: Not reported  
Cadmium cleaned up: Not reported  
Chromium cleaned up: Not reported  
Copper cleaned up: Not reported  
Iron cleaned up: Not reported  
mercury cleaned up: Not reported  
nickel cleaned up: Not reported  
No clean up: Not reported  
Pesticides cleaned up: Not reported  
Selenium cleaned up: Not reported  
SVOCs cleaned up: Not reported  
Unknown clean up: Not reported  
Arsenic contaminant found: Not reported  
Cadmium contaminant found: Not reported  
Chromium contaminant found: Not reported  
Copper contaminant found: Not reported  
Iron contaminant found: Not reported  
Mercury contaminant found: Not reported  
Nickel contaminant found: Not reported  
No contaminant found: Not reported  
Pesticides contaminant found: Not reported  
Selenium contaminant found: Not reported  
SVOCs contaminant found: Not reported  
Unknown contaminant found: Not reported  
Future Use: Multistory Not reported  
Media affected Bluiding Material: Not reported  
Media affected indoor air: Not reported  
Building material media cleaned up: Not reported  
Indoor air media cleaned up: Not reported  
Unknown media cleaned up: Not reported  
Past Use: Multistory Not reported

Recipient name: Gulfport, City of  
Grant type: Assessment  
Property name: 2120 25TH AV  
Property #: 0811F-05-054.00  
Parcel size: .18  
Property Description: At the time of the site reconnaissance performed on July 10, 2012, the property was in use as two unoccupied office suites (Suite A and Suite B) and two commercially occupied office suites (Suite C and Suite D). The property is owned by Mr. Glenn Miller.Mr. Miller

Map ID  
Direction  
Distance  
Elevation

MAP FINDINGS

Site

Database(s)

EDR ID Number  
EPA ID Number

2120 25TH AV (Continued)

1016159031

indicated that the original portions of the existing building were first constructed in 1922. When Mr. Miller purchased the property in 2005, the building was occupied by Showgirls Lingerie. In 2006, Mr. Miller indicated that the property was completely remodeled in order to comply with building codes at that time. From 2006 through 2008 the building was occupied by Blue Cliff College, and from 2008 to present the property has been leased to various tenants for office space, according to Mr. Miller. A review of city directories depicts the property as historically being commercially occupied. Con Survey City Directory lists the property as an insurance company in 1962 and 1968. Polks City Directory lists the property as an auto parts store in 1978, an antique shop in 1984, Showgirls Lingerie in 2002, Blue Cliff College in 2007, and Beyers Engineering in 2012. In 1973 the property was listed as vacant, and in 1990 and 1997 it was not listed in the Polks City Directories. The historical use of the property for automotive service, and the former presence of a gasoline underground storage tank and solvent tank represent a recognized environmental condition.

Latitude:	30.376485
Longitude:	-89.092574
HCM label:	Address Matching-House Number
Map scale:	Not reported
Point of reference:	Entrance Point of a Facility or Station
Datum:	North American Datum of 1983
ACRES property ID:	150081
Start date:	Not reported
Completed date:	Not reported
Acres cleaned up:	Not reported
Cleanup funding:	Not reported
Cleanup funding source:	Not reported
Assessment funding:	16756
Assessment funding source:	US EPA - Brownfields Assessment Cooperative Agreement
Redevelopment funding:	500000
Redev. funding source:	Private/Other Funding
Redev. funding entity name:	Private Bank
Redevelopment start date:	05/17/2013 00:00:00
Assessment funding entity:	EPA
Cleanup funding entity:	Not reported
Grant type:	B
Accomplishment type:	Phase II Environmental Assessment
Accomplishment count:	0
Cooperative agreement #:	95482611
Ownership entity:	Private
Current owner:	Mr. Glenn Miller
Did owner change:	N
Cleanup required:	No
Video available:	No
Photo available:	Yes
Institutional controls required:	N
IC Category proprietary controls:	Not reported
IC cat. info. devices:	Not reported
IC cat. gov. controls:	Not reported
IC cat. enforcement permit tools:	Not reported
IC in place date:	Not reported
IC in place:	No
State/tribal program date:	Not reported
State/tribal program ID:	Not reported

Map ID  
Direction  
Distance  
Elevation

MAP FINDINGS

Site

Database(s)

EDR ID Number  
EPA ID Number

**2120 25TH AV (Continued)**

**1016159031**

State/tribal NFA date:	05/17/2013 00:00:00
Air contaminated:	Not reported
Air cleaned:	Not reported
Asbestos found:	Not reported
Asbestos cleaned:	Not reported
Controlled substance found:	Not reported
Controlled substance cleaned:	Not reported
Drinking water affected:	Not reported
Drinking water cleaned:	Not reported
Groundwater affected:	Not reported
Groundwater cleaned:	Not reported
Lead contaminant found:	Not reported
Lead cleaned up:	Not reported
No media affected:	Not reported
Unknown media affected:	Not reported
Other cleaned up:	Not reported
Other metals found:	Not reported
Other metals cleaned:	Not reported
Other contaminants found:	Not reported
Other contams found description:	Not reported
PAHs found:	Not reported
PAHs cleaned up:	Not reported
PCBs found:	Not reported
PCBs cleaned up:	Not reported
Petro products found:	Not reported
Petro products cleaned:	Not reported
Sediments found:	Not reported
Sediments cleaned:	Not reported
Soil affected:	Not reported
Soil cleaned up:	Not reported
Surface water cleaned:	Not reported
VOCs found:	Not reported
VOCs cleaned:	Not reported
Cleanup other description:	Not reported
Num. of cleanup and re-dev. jobs:	0
Past use greenspace acreage:	Not reported
Past use residential acreage:	Not reported
Past use commercial acreage:	.18
Past use industrial acreage:	Not reported
Future use greenspace acreage:	Not reported
Future use residential acreage:	Not reported
Future use commercial acreage:	.18
Future use industrial acreage:	Not reported
Greenspace acreage and type:	Not reported
Superfund Fed. landowner flag:	Not reported
Arsenic cleaned up:	Not reported
Cadmium cleaned up:	Not reported
Chromium cleaned up:	Not reported
Copper cleaned up:	Not reported
Iron cleaned up:	Not reported
mercury cleaned up:	Not reported
nickel cleaned up:	Not reported
No clean up:	Not reported
Pesticides cleaned up:	Not reported
Selenium cleaned up:	Not reported
SVOCs cleaned up:	Not reported
Unknown clean up:	Not reported

Map ID  
Direction  
Distance  
Elevation

MAP FINDINGS

Site

Database(s)

EDR ID Number  
EPA ID Number

**2120 25TH AV (Continued)**

**1016159031**

Arsenic contaminant found: Not reported  
Cadmium contaminant found: Not reported  
Chromium contaminant found: Not reported  
Copper contaminant found: Not reported  
Iron contaminant found: Not reported  
Mercury contaminant found: Not reported  
Nickel contaminant found: Not reported  
No contaminant found: Not reported  
Pesticides contaminant found: Not reported  
Selenium contaminant found: Not reported  
SVOCs contaminant found: Not reported  
Unknown contaminant found: Not reported  
Future Use: Multistory Not reported  
Media affected Bluiding Material: Not reported  
Media affected indoor air: Not reported  
Building material media cleaned up: Not reported  
Indoor air media cleaned up: Not reported  
Unknown media cleaned up: Not reported  
Past Use: Multistory Not reported

Recipient name: Gulfport, City of  
Grant type: Assessment  
Property name: 2120 25TH AV  
Property #: 0811F-05-054.00  
Parcel size: .18  
Property Description:

At the time of the site reconnaissance performed on July 10, 2012, the property was in use as two unoccupied office suites (Suite A and Suite B) and two commercially occupied office suites (Suite C and Suite D). The property is owned by Mr. Glenn Miller. Mr. Miller indicated that the original portions of the existing building were first constructed in 1922. When Mr. Miller purchased the property in 2005, the building was occupied by Showgirls Lingerie. In 2006, Mr. Miller indicated that the property was completely remodeled in order to comply with building codes at that time. From 2006 through 2008 the building was occupied by Blue Cliff College, and from 2008 to present the property has been leased to various tenants for office space, according to Mr. Miller. A review of city directories depicts the property as historically being commercially occupied. Con Survey City Directory lists the property as an insurance company in 1962 and 1968. Polks City Directory lists the property as an auto parts store in 1978, an antique shop in 1984, Showgirls Lingerie in 2002, Blue Cliff College in 2007, and Beyers Engineering in 2012. In 1973 the property was listed as vacant, and in 1990 and 1997 it was not listed in the Polks City Directories. The historical use of the property for automotive service, and the former presence of a gasoline underground storage tank and solvent tank represent a recognized environmental condition.

Latitude: 30.376485  
Longitude: -89.092574  
HCM label: Address Matching-House Number  
Map scale: Not reported  
Point of reference: Entrance Point of a Facility or Station  
Datum: North American Datum of 1983  
ACRES property ID: 150081  
Start date: Not reported  
Completed date: Not reported  
Acres cleaned up: Not reported

Map ID  
Direction  
Distance  
Elevation

MAP FINDINGS

Site

Database(s)

EDR ID Number  
EPA ID Number

2120 25TH AV (Continued)

1016159031

Cleanup funding:	Not reported
Cleanup funding source:	Not reported
Assessment funding:	3485
Assessment funding source:	US EPA - Brownfields Assessment Cooperative Agreement
Redevelopment funding:	500000
Redev. funding source:	Private/Other Funding
Redev. funding entity name:	Private Bank
Redevelopment start date:	05/17/2013 00:00:00
Assessment funding entity:	EPA
Cleanup funding entity:	Not reported
Grant type:	B
Accomplishment type:	Phase I Environmental Assessment
Accomplishment count:	1
Cooperative agreement #:	95482611
Ownership entity:	Private
Current owner:	Mr. Glenn Miller
Did owner change:	N
Cleanup required:	No
Video available:	No
Photo available:	Yes
Institutional controls required:	N
IC Category proprietary controls:	Not reported
IC cat. info. devices:	Not reported
IC cat. gov. controls:	Not reported
IC cat. enforcement permit tools:	Not reported
IC in place date:	Not reported
IC in place:	No
State/tribal program date:	Not reported
State/tribal program ID:	Not reported
State/tribal NFA date:	05/17/2013 00:00:00
Air contaminated:	Not reported
Air cleaned:	Not reported
Asbestos found:	Not reported
Asbestos cleaned:	Not reported
Controlled substance found:	Not reported
Controlled substance cleaned:	Not reported
Drinking water affected:	Not reported
Drinking water cleaned:	Not reported
Groundwater affected:	Not reported
Groundwater cleaned:	Not reported
Lead contaminant found:	Not reported
Lead cleaned up:	Not reported
No media affected:	Not reported
Unknown media affected:	Not reported
Other cleaned up:	Not reported
Other metals found:	Not reported
Other metals cleaned:	Not reported
Other contaminants found:	Not reported
Other contams found description:	Not reported
PAHs found:	Not reported
PAHs cleaned up:	Not reported
PCBs found:	Not reported
PCBs cleaned up:	Not reported
Petro products found:	Not reported
Petro products cleaned:	Not reported
Sediments found:	Not reported
Sediments cleaned:	Not reported

Map ID  
Direction  
Distance  
Elevation

MAP FINDINGS

Site

Database(s)

EDR ID Number  
EPA ID Number

**2120 25TH AV (Continued)**

**1016159031**

Soil affected:	Not reported
Soil cleaned up:	Not reported
Surface water cleaned:	Not reported
VOCs found:	Not reported
VOCs cleaned:	Not reported
Cleanup other description:	Not reported
Num. of cleanup and re-dev. jobs:	0
Past use greenspace acreage:	Not reported
Past use residential acreage:	Not reported
Past use commercial acreage:	.18
Past use industrial acreage:	Not reported
Future use greenspace acreage:	Not reported
Future use residential acreage:	Not reported
Future use commercial acreage:	.18
Future use industrial acreage:	Not reported
Greenspace acreage and type:	Not reported
Superfund Fed. landowner flag:	Not reported
Arsenic cleaned up:	Not reported
Cadmium cleaned up:	Not reported
Chromium cleaned up:	Not reported
Copper cleaned up:	Not reported
Iron cleaned up:	Not reported
mercury cleaned up:	Not reported
nickel cleaned up:	Not reported
No clean up:	Not reported
Pesticides cleaned up:	Not reported
Selenium cleaned up:	Not reported
SVOCs cleaned up:	Not reported
Unknown clean up:	Not reported
Arsenic contaminant found:	Not reported
Cadmium contaminant found:	Not reported
Chromium contaminant found:	Not reported
Copper contaminant found:	Not reported
Iron contaminant found:	Not reported
Mercury contaminant found:	Not reported
Nickel contaminant found:	Not reported
No contaminant found:	Not reported
Pesticides contaminant found:	Not reported
Selenium contaminant found:	Not reported
SVOCs contaminant found:	Not reported
Unknown contaminant found:	Not reported
Future Use: Multistory	Not reported
Media affected Bluiding Material:	Not reported
Media affected indoor air:	Not reported
Building material media cleaned up:	Not reported
Indoor air media cleaned up:	Not reported
Unknown media cleaned up:	Not reported
Past Use: Multistory	Not reported

Map ID  
Direction  
Distance  
Elevation

MAP FINDINGS

Site

Database(s) EDR ID Number  
EPA ID Number

170  
North  
1/2-1  
0.853 mi.  
4502 ft.

MID SOUTH RR REFUELING STATION - GULFPORT  
GULFPORT, MS

SHWS S106593346  
N/A

Relative:  
Higher

SHWS:  
Lat/Long (dms): 30 22 36 / 89 5 43  
Site Size (acres): <1  
EPA ID: Not reported  
Project Manager: Not reported  
**Status: RUAO**  
State No Further Action Date: Not reported  
Federal: Not reported  
Federal No Further Action Date: Not reported  
Soil Contamination: Yes  
Surface Water Contamination: No  
Ground Water Contamination: No  
Remediation Type: Not reported  
Surface Water Remediation: Not reported  
GW Remediation Type: Not reported  
Maj. Contaminant: TPH  
High Concentration: 2.85E+04  
High Concentration Units: mg/kg  
Institutional Control: Not reported  
Engineering Control: Not reported  
Voluntary Cleanups: Not reported

Actual:  
30 ft.

AE171  
NNE  
1/2-1  
0.856 mi.  
4519 ft.

BROADNAX PROPERTY (PARCEL #0811F-05-053.000)  
GULFPORT, MS  
Site 2 of 2 in cluster AE

SHWS S113400038  
N/A

Relative:  
Higher

SHWS:  
Lat/Long (dms): 30 22 35 / 89 5 33  
Site Size (acres): 0.27  
EPA ID: Not reported  
Project Manager: McKercher, Willie  
**Status: SNFA**  
State No Further Action Date: 05/17/2013  
Federal: Not reported  
Federal No Further Action Date: Not reported  
Soil Contamination: No  
Surface Water Contamination: No  
Ground Water Contamination: No  
Remediation Type: Not reported  
Surface Water Remediation: Not reported  
GW Remediation Type: Not reported  
Maj. Contaminant: Recognized Environmental Conditions  
High Concentration: Not reported  
High Concentration Units: Not reported  
Institutional Control: Not reported  
Engineering Control: Not reported  
Voluntary Cleanups: Not reported

Actual:  
30 ft.



Map ID  
Direction  
Distance  
Elevation

MAP FINDINGS

Site

Database(s)

EDR ID Number  
EPA ID Number

172  
NNE  
1/2-1  
0.875 mi.  
4618 ft.

MILLER PROPERTY - 2120 25TH AVENUE  
GULFPORT, MS

SHWS S113400039  
N/A

Relative:  
Higher

SHWS:

Lat/Long (dms): 30 22 36 / 89 5 33  
Site Size (acres): 0.18  
EPA ID: Not reported  
Project Manager: Not reported  
**Status: Not reported**  
State No Further Action Date: Not reported  
Federal: Not reported  
Federal No Further Action Date: Not reported  
Soil Contamination: No  
Surface Water Contamination: No  
Ground Water Contamination: No  
Remediation Type: Not reported  
Surface Water Remediation: Not reported  
GW Remediation Type: Not reported  
Maj. Contaminant: Recognized Environmental Conditions  
High Concentration: Not reported  
High Concentration Units: Not reported  
Institutional Control: Not reported  
Engineering Control: Not reported  
Voluntary Cleanups: Not reported

Actual:  
30 ft.

173  
North  
1/2-1  
0.891 mi.  
4704 ft.

MDOT - JOE SCHAPENS PROPERTY  
GULFPORT, MS

SHWS S108634344  
N/A

Relative:  
Higher

SHWS:

Lat/Long (dms): 30 22 38 / 89 5 47  
Site Size (acres): Not reported  
EPA ID: Not reported  
Project Manager: Not reported  
**Status: SNFA**  
State No Further Action Date: 07/19/2001  
Federal: Not reported  
Federal No Further Action Date: Not reported  
Soil Contamination: No  
Surface Water Contamination: No  
Ground Water Contamination: No  
Remediation Type: Not reported  
Surface Water Remediation: Not reported  
GW Remediation Type: Not reported  
Maj. Contaminant: Not reported  
High Concentration: Not reported  
High Concentration Units: Not reported  
Institutional Control: Not reported  
Engineering Control: Not reported  
Voluntary Cleanups: Not reported

Actual:  
23 ft.

MAP FINDINGS

Map ID  
Direction  
Distance  
Elevation

Site

Database(s)

EDR ID Number  
EPA ID Number

174  
WSW  
1/2-1  
0.901 mi.  
4756 ft.

**DIXIE #10**  
**4100 WEST BEACH STREET**  
**GULFPORT, MS 39501**

**LUST U001297401**  
**N/A**

**Relative:**  
**Higher**

Facility Id: 9745  
Facility Satus: Inactive  
Lust Status: Closed  
AIID: 26498  
Event #: 1  
Project Manager: Larry Flynt  
Date Of Report: 02/17/1993  
Trust Fund Status: NTFE  
Confirmed On: 02/17/1993  
NFA Date: 11/12/1993

**Actual:**  
**10 ft.**

Facility Id: 9745  
Facility Satus: Inactive  
Lust Status: Closed  
AIID: 26498  
Event #: 2  
Project Manager: Lynn Chambers  
Date Of Report: 10/01/1995  
Trust Fund Status: EUD  
Confirmed On: 10/01/1995  
NFA Date: 06/03/1997

Facility Id: 9745  
Facility Satus: Inactive  
Lust Status: Closed  
AIID: 26498  
Event #: 3  
Project Manager: Robert Huckaby  
Date Of Report: 04/14/2000  
Trust Fund Status: EUD  
Confirmed On: 04/12/2000  
NFA Date: 03/16/2001

175  
WSW  
1/2-1  
0.981 mi.  
5180 ft.

**PARKSIDE EXXON**  
**4220 WEST BEACH BOULEVARD**  
**GULFPORT, MS 39501**

**LUST U001295818**  
**N/A**

**Relative:**  
**Higher**

Facility Id: 3634  
Facility Satus: Inactive  
Lust Status: Closed  
AIID: 15979  
Event #: 1  
Project Manager: Larry Flynt  
Date Of Report: 09/11/1989  
Trust Fund Status: STFS  
Confirmed On: 09/11/1989  
NFA Date: 08/29/1995

**Actual:**  
**10 ft.**

Facility Id: 3634  
Facility Satus: Inactive

Map ID  
 Direction  
 Distance  
 Elevation

MAP FINDINGS

Site

Database(s)

EDR ID Number  
 EPA ID Number

**PARKSIDE EXXON (Continued)**

**U001295818**

Lust Status: Closed  
 AIID: 15979  
 Event #: 2  
 Project Manager: Heather Pitts  
 Date Of Report: 06/07/1999  
 Trust Fund Status: STFS  
 Confirmed On: 06/02/1999  
 NFA Date: 06/11/2004

Facility Id: 3634  
 Facility Satus: Inactive  
 Lust Status: Closed  
 AIID: 15979  
 Event #: 3  
 Project Manager: Michael Usry  
 Date Of Report: 10/17/2006  
 Trust Fund Status: Katrina  
 Confirmed On: 12/21/2006  
 NFA Date: 01/03/2007

176  
 North  
 > 1  
 1.150 mi.  
 6074 ft.

**MDOT - GULFPORT 2513 30TH AVENUE**  
**GULFPORT, MS**

**SHWS S109485397**  
**N/A**

**Relative:**  
**Higher**

SHWS:  
 Lat/Long (dms): 30 22 51 / 89 5 53  
 Site Size (acres): <1  
 EPA ID: Not reported  
 Project Manager: Not reported  
**Status: Not reported**  
 State No Further Action Date: Not reported  
 Federal: Not reported  
 Federal No Further Action Date: Not reported  
 Soil Contamination: Yes  
 Surface Water Contamination: No  
 Ground Water Contamination: No  
 Remediation Type: Not reported  
 Surface Water Remediation: Not reported  
 GW Remediation Type: Not reported  
 Maj. Contaminant: Hydraulic oil  
 High Concentration: Not reported  
 High Concentration Units: Not reported  
 Institutional Control: Not reported  
 Engineering Control: Not reported  
 Voluntary Cleanups: Not reported

**Actual:**  
**20 ft.**

Map ID  
 Direction  
 Distance  
 Elevation

MAP FINDINGS

Site

Database(s)

EDR ID Number  
 EPA ID Number

177  
 NNW  
 > 1  
 1.164 mi.  
 6146 ft.

**HOLCOMB PAINT FACTORY (FORMER)**  
**GULFPOR, MS**

**SHWS S105709538**  
**N/A**

**Relative:**  
**Higher**

SHWS:  
 Lat/Long (dms): 30 22 50 / 89 6 4  
 Site Size (acres): Not reported  
 EPA ID: Not reported  
 Project Manager: Not reported  
**Status: Inactive**  
 State No Further Action Date: Not reported  
 Federal: Not reported  
 Federal No Further Action Date: Not reported  
 Soil Contamination: Yes  
 Surface Water Contamination: No  
 Ground Water Contamination: Yes  
 Remediation Type: Not reported  
 Surface Water Remediation: Not reported  
 GW Remediation Type: Not reported  
 Maj. Contaminant: TPH  
 High Concentration: 1.58E+04  
 High Concentration Units: mg/kg  
 Institutional Control: Not reported  
 Engineering Control: Not reported  
 Voluntary Cleanups: Not reported

178  
 NE  
 > 1  
 1.433 mi.  
 7568 ft.

**GULFPOR TIRE**  
**GULFPOR, MS**

**SHWS S117279905**  
**N/A**

**Relative:**  
**Higher**

SHWS:  
 Lat/Long (dms): 30 22 52 / 89 4 54  
 Site Size (acres): <1  
 EPA ID: Not reported  
 Project Manager: McKercher, Willie  
**Status: BFA**  
 State No Further Action Date: 05/22/2014  
 Federal: Not reported  
 Federal No Further Action Date: Not reported  
 Soil Contamination: No  
 Surface Water Contamination: No  
 Ground Water Contamination: Yes  
 Remediation Type: Not reported  
 Surface Water Remediation: Not reported  
 GW Remediation Type: IC  
 Maj. Contaminant: Benzene  
 High Concentration: Not reported  
 High Concentration Units: Not reported  
 Institutional Control: 05/22/2014  
 Engineering Control: Not reported  
 Voluntary Cleanups: BF

**Actual:**  
**33 ft.**

Count: 2 records.

ORPHAN SUMMARY

City	EDR ID	Site Name	Site Address	Zip	Database(s)
GULFPORT	1016021614	MITCHELL COMPANY INC, THE, THE HAM	WEST BEACH BOULEVARD	39502	FINDS
GULFPORT	U001300362	MAJIK MARKET #04486	COLLEGE PARK & PASS ROAD	39501	LUST, UST

# GOVERNMENT RECORDS SEARCHED / DATA CURRENCY TRACKING

To maintain currency of the following federal and state databases, EDR contacts the appropriate governmental agency on a monthly or quarterly basis, as required.

**Number of Days to Update:** Provides confirmation that EDR is reporting records that have been updated within 90 days from the date the government agency made the information available to the public.

## STANDARD ENVIRONMENTAL RECORDS

### ***Federal NPL site list***

#### NPL: National Priority List

National Priorities List (Superfund). The NPL is a subset of CERCLIS and identifies over 1,200 sites for priority cleanup under the Superfund Program. NPL sites may encompass relatively large areas. As such, EDR provides polygon coverage for over 1,000 NPL site boundaries produced by EPA's Environmental Photographic Interpretation Center (EPIC) and regional EPA offices.

Date of Government Version: 03/26/2015	Source: EPA
Date Data Arrived at EDR: 04/08/2015	Telephone: N/A
Date Made Active in Reports: 06/22/2015	Last EDR Contact: 07/09/2015
Number of Days to Update: 75	Next Scheduled EDR Contact: 10/19/2015
	Data Release Frequency: Quarterly

#### NPL Site Boundaries

##### Sources:

EPA's Environmental Photographic Interpretation Center (EPIC)  
Telephone: 202-564-7333

EPA Region 1  
Telephone 617-918-1143

EPA Region 6  
Telephone: 214-655-6659

EPA Region 3  
Telephone 215-814-5418

EPA Region 7  
Telephone: 913-551-7247

EPA Region 4  
Telephone 404-562-8033

EPA Region 8  
Telephone: 303-312-6774

EPA Region 5  
Telephone 312-886-6686

EPA Region 9  
Telephone: 415-947-4246

EPA Region 10  
Telephone 206-553-8665

#### Proposed NPL: Proposed National Priority List Sites

A site that has been proposed for listing on the National Priorities List through the issuance of a proposed rule in the Federal Register. EPA then accepts public comments on the site, responds to the comments, and places on the NPL those sites that continue to meet the requirements for listing.

Date of Government Version: 03/26/2015	Source: EPA
Date Data Arrived at EDR: 04/08/2015	Telephone: N/A
Date Made Active in Reports: 06/22/2015	Last EDR Contact: 07/09/2015
Number of Days to Update: 75	Next Scheduled EDR Contact: 10/19/2015
	Data Release Frequency: Quarterly

#### NPL LIENS: Federal Superfund Liens

Federal Superfund Liens. Under the authority granted the USEPA by CERCLA of 1980, the USEPA has the authority to file liens against real property in order to recover remedial action expenditures or when the property owner received notification of potential liability. USEPA compiles a listing of filed notices of Superfund Liens.

Date of Government Version: 10/15/1991	Source: EPA
Date Data Arrived at EDR: 02/02/1994	Telephone: 202-564-4267
Date Made Active in Reports: 03/30/1994	Last EDR Contact: 08/15/2011
Number of Days to Update: 56	Next Scheduled EDR Contact: 11/28/2011
	Data Release Frequency: No Update Planned

# GOVERNMENT RECORDS SEARCHED / DATA CURRENCY TRACKING

## ***Federal Delisted NPL site list***

Delisted NPL: National Priority List Deletions

The National Oil and Hazardous Substances Pollution Contingency Plan (NCP) establishes the criteria that the EPA uses to delete sites from the NPL. In accordance with 40 CFR 300.425.(e), sites may be deleted from the NPL where no further response is appropriate.

Date of Government Version: 03/26/2015	Source: EPA
Date Data Arrived at EDR: 04/08/2015	Telephone: N/A
Date Made Active in Reports: 06/22/2015	Last EDR Contact: 07/09/2015
Number of Days to Update: 75	Next Scheduled EDR Contact: 10/19/2015
	Data Release Frequency: Quarterly

## ***Federal CERCLIS list***

FEDERAL FACILITY: Federal Facility Site Information listing

A listing of National Priority List (NPL) and Base Realignment and Closure (BRAC) sites found in the Comprehensive Environmental Response, Compensation and Liability Information System (CERCLIS) Database where EPA Federal Facilities Restoration and Reuse Office is involved in cleanup activities.

Date of Government Version: 03/26/2015	Source: Environmental Protection Agency
Date Data Arrived at EDR: 04/08/2015	Telephone: 703-603-8704
Date Made Active in Reports: 06/11/2015	Last EDR Contact: 07/10/2015
Number of Days to Update: 64	Next Scheduled EDR Contact: 10/19/2015
	Data Release Frequency: Varies

CERCLIS: Comprehensive Environmental Response, Compensation, and Liability Information System

CERCLIS contains data on potentially hazardous waste sites that have been reported to the USEPA by states, municipalities, private companies and private persons, pursuant to Section 103 of the Comprehensive Environmental Response, Compensation, and Liability Act (CERCLA). CERCLIS contains sites which are either proposed to or on the National Priorities List (NPL) and sites which are in the screening and assessment phase for possible inclusion on the NPL.

Date of Government Version: 10/25/2013	Source: EPA
Date Data Arrived at EDR: 11/11/2013	Telephone: 703-412-9810
Date Made Active in Reports: 02/13/2014	Last EDR Contact: 05/29/2015
Number of Days to Update: 94	Next Scheduled EDR Contact: 09/07/2015
	Data Release Frequency: Quarterly

## ***Federal CERCLIS NFRAP site List***

CERCLIS-NFRAP: CERCLIS No Further Remedial Action Planned

Archived sites are sites that have been removed and archived from the inventory of CERCLIS sites. Archived status indicates that, to the best of EPA's knowledge, assessment at a site has been completed and that EPA has determined no further steps will be taken to list this site on the National Priorities List (NPL), unless information indicates this decision was not appropriate or other considerations require a recommendation for listing at a later time. This decision does not necessarily mean that there is no hazard associated with a given site; it only means that, based upon available information, the location is not judged to be a potential NPL site.

Date of Government Version: 10/25/2013	Source: EPA
Date Data Arrived at EDR: 11/11/2013	Telephone: 703-412-9810
Date Made Active in Reports: 02/13/2014	Last EDR Contact: 05/29/2015
Number of Days to Update: 94	Next Scheduled EDR Contact: 09/07/2015
	Data Release Frequency: Quarterly

## ***Federal RCRA CORRACTS facilities list***

CORRACTS: Corrective Action Report

CORRACTS identifies hazardous waste handlers with RCRA corrective action activity.

# GOVERNMENT RECORDS SEARCHED / DATA CURRENCY TRACKING

Date of Government Version: 03/10/2015  
Date Data Arrived at EDR: 03/31/2015  
Date Made Active in Reports: 06/11/2015  
Number of Days to Update: 72

Source: EPA  
Telephone: 800-424-9346  
Last EDR Contact: 06/26/2015  
Next Scheduled EDR Contact: 10/12/2015  
Data Release Frequency: Quarterly

## ***Federal RCRA non-CORRACTS TSD facilities list***

### **RCRA-TSDF: RCRA - Treatment, Storage and Disposal**

RCRAInfo is EPA's comprehensive information system, providing access to data supporting the Resource Conservation and Recovery Act (RCRA) of 1976 and the Hazardous and Solid Waste Amendments (HSWA) of 1984. The database includes selective information on sites which generate, transport, store, treat and/or dispose of hazardous waste as defined by the Resource Conservation and Recovery Act (RCRA). Transporters are individuals or entities that move hazardous waste from the generator offsite to a facility that can recycle, treat, store, or dispose of the waste. TSDFs treat, store, or dispose of the waste.

Date of Government Version: 03/10/2015  
Date Data Arrived at EDR: 03/31/2015  
Date Made Active in Reports: 06/11/2015  
Number of Days to Update: 72

Source: Environmental Protection Agency  
Telephone: (404) 562-8651  
Last EDR Contact: 06/26/2015  
Next Scheduled EDR Contact: 10/12/2015  
Data Release Frequency: Quarterly

## ***Federal RCRA generators list***

### **RCRA-LQG: RCRA - Large Quantity Generators**

RCRAInfo is EPA's comprehensive information system, providing access to data supporting the Resource Conservation and Recovery Act (RCRA) of 1976 and the Hazardous and Solid Waste Amendments (HSWA) of 1984. The database includes selective information on sites which generate, transport, store, treat and/or dispose of hazardous waste as defined by the Resource Conservation and Recovery Act (RCRA). Large quantity generators (LQGs) generate over 1,000 kilograms (kg) of hazardous waste, or over 1 kg of acutely hazardous waste per month.

Date of Government Version: 03/10/2015  
Date Data Arrived at EDR: 03/31/2015  
Date Made Active in Reports: 06/11/2015  
Number of Days to Update: 72

Source: Environmental Protection Agency  
Telephone: (404) 562-8651  
Last EDR Contact: 06/26/2015  
Next Scheduled EDR Contact: 10/12/2015  
Data Release Frequency: Quarterly

### **RCRA-SQG: RCRA - Small Quantity Generators**

RCRAInfo is EPA's comprehensive information system, providing access to data supporting the Resource Conservation and Recovery Act (RCRA) of 1976 and the Hazardous and Solid Waste Amendments (HSWA) of 1984. The database includes selective information on sites which generate, transport, store, treat and/or dispose of hazardous waste as defined by the Resource Conservation and Recovery Act (RCRA). Small quantity generators (SQGs) generate between 100 kg and 1,000 kg of hazardous waste per month.

Date of Government Version: 03/10/2015  
Date Data Arrived at EDR: 03/31/2015  
Date Made Active in Reports: 06/11/2015  
Number of Days to Update: 72

Source: Environmental Protection Agency  
Telephone: (404) 562-8651  
Last EDR Contact: 06/26/2015  
Next Scheduled EDR Contact: 10/12/2015  
Data Release Frequency: Quarterly

### **RCRA-CESQG: RCRA - Conditionally Exempt Small Quantity Generators**

RCRAInfo is EPA's comprehensive information system, providing access to data supporting the Resource Conservation and Recovery Act (RCRA) of 1976 and the Hazardous and Solid Waste Amendments (HSWA) of 1984. The database includes selective information on sites which generate, transport, store, treat and/or dispose of hazardous waste as defined by the Resource Conservation and Recovery Act (RCRA). Conditionally exempt small quantity generators (CESQGs) generate less than 100 kg of hazardous waste, or less than 1 kg of acutely hazardous waste per month.

Date of Government Version: 03/10/2015  
Date Data Arrived at EDR: 03/31/2015  
Date Made Active in Reports: 06/11/2015  
Number of Days to Update: 72

Source: Environmental Protection Agency  
Telephone: (404) 562-8651  
Last EDR Contact: 06/26/2015  
Next Scheduled EDR Contact: 10/12/2015  
Data Release Frequency: Varies



# GOVERNMENT RECORDS SEARCHED / DATA CURRENCY TRACKING

## ***Federal institutional controls / engineering controls registries***

### **LUCIS: Land Use Control Information System**

LUCIS contains records of land use control information pertaining to the former Navy Base Realignment and Closure properties.

Date of Government Version: 05/28/2015	Source: Department of the Navy
Date Data Arrived at EDR: 05/29/2015	Telephone: 843-820-7326
Date Made Active in Reports: 06/11/2015	Last EDR Contact: 08/12/2015
Number of Days to Update: 13	Next Scheduled EDR Contact: 11/30/2015
	Data Release Frequency: Varies

### **US ENG CONTROLS: Engineering Controls Sites List**

A listing of sites with engineering controls in place. Engineering controls include various forms of caps, building foundations, liners, and treatment methods to create pathway elimination for regulated substances to enter environmental media or effect human health.

Date of Government Version: 06/09/2015	Source: Environmental Protection Agency
Date Data Arrived at EDR: 06/26/2015	Telephone: 703-603-0695
Date Made Active in Reports: 09/02/2015	Last EDR Contact: 08/31/2015
Number of Days to Update: 68	Next Scheduled EDR Contact: 12/14/2015
	Data Release Frequency: Varies

### **US INST CONTROL: Sites with Institutional Controls**

A listing of sites with institutional controls in place. Institutional controls include administrative measures, such as groundwater use restrictions, construction restrictions, property use restrictions, and post remediation care requirements intended to prevent exposure to contaminants remaining on site. Deed restrictions are generally required as part of the institutional controls.

Date of Government Version: 06/09/2015	Source: Environmental Protection Agency
Date Data Arrived at EDR: 06/26/2015	Telephone: 703-603-0695
Date Made Active in Reports: 09/02/2015	Last EDR Contact: 08/31/2015
Number of Days to Update: 68	Next Scheduled EDR Contact: 12/14/2015
	Data Release Frequency: Varies

## ***Federal ERNS list***

### **ERNS: Emergency Response Notification System**

Emergency Response Notification System. ERNS records and stores information on reported releases of oil and hazardous substances.

Date of Government Version: 03/30/2015	Source: National Response Center, United States Coast Guard
Date Data Arrived at EDR: 03/31/2015	Telephone: 202-267-2180
Date Made Active in Reports: 06/02/2015	Last EDR Contact: 06/26/2015
Number of Days to Update: 63	Next Scheduled EDR Contact: 10/12/2015
	Data Release Frequency: Annually

## ***State- and tribal - equivalent CERCLIS***

### **SHWS: CERCLA/Uncontrolled Sites File List**

State Hazardous Waste Sites. State hazardous waste site records are the states' equivalent to CERCLIS. These sites may or may not already be listed on the federal CERCLIS list. Priority sites planned for cleanup using state funds (state equivalent of Superfund) are identified along with sites where cleanup will be paid for by potentially responsible parties. Available information varies by state.

Date of Government Version: 06/15/2015	Source: Department of Environmental Quality
Date Data Arrived at EDR: 06/29/2015	Telephone: 601-961-5666
Date Made Active in Reports: 07/20/2015	Last EDR Contact: 06/27/2015
Number of Days to Update: 21	Next Scheduled EDR Contact: 10/12/2015
	Data Release Frequency: Annually

# GOVERNMENT RECORDS SEARCHED / DATA CURRENCY TRACKING

## **State and tribal landfill and/or solid waste disposal site lists**

### SWF/LF: Solid Waste Landfills

Solid Waste Facilities/Landfill Sites. SWF/LF type records typically contain an inventory of solid waste disposal facilities or landfills in a particular state. Depending on the state, these may be active or inactive facilities or open dumps that failed to meet RCRA Subtitle D Section 4004 criteria for solid waste landfills or disposal sites.

Date of Government Version: 07/01/2014	Source: Department of Environmental Quality
Date Data Arrived at EDR: 08/27/2014	Telephone: 601-961-5082
Date Made Active in Reports: 10/13/2014	Last EDR Contact: 05/29/2015
Number of Days to Update: 47	Next Scheduled EDR Contact: 09/07/2015
	Data Release Frequency: Semi-Annually

### DEBRIS: Debris Site Locations Listing

A listing of Hurricane Katrina debris disposal site locations. Not all of these sites were approved or utilized. Please note that the list includes a number of different types of sites including vegetative debris burn, chip, staging and disposal sites as well as structural debris staging and disposal sites.

Date of Government Version: 06/17/2008	Source: Department of Environmental Quality
Date Data Arrived at EDR: 06/17/2008	Telephone: 601-961-5726
Date Made Active in Reports: 07/31/2008	Last EDR Contact: 05/22/2015
Number of Days to Update: 44	Next Scheduled EDR Contact: 09/07/2015
	Data Release Frequency: Varies

## **State and tribal leaking storage tank lists**

### LUST: Leaking Underground Storage Tank Database

Leaking Underground Storage Tank Incident Reports. LUST records contain an inventory of reported leaking underground storage tank incidents. Not all states maintain these records, and the information stored varies by state.

Date of Government Version: 06/24/2015	Source: Department of Environmental Quality
Date Data Arrived at EDR: 06/29/2015	Telephone: 601-961-5058
Date Made Active in Reports: 07/20/2015	Last EDR Contact: 06/26/2015
Number of Days to Update: 21	Next Scheduled EDR Contact: 10/12/2015
	Data Release Frequency: Quarterly

### INDIAN LUST R1: Leaking Underground Storage Tanks on Indian Land

A listing of leaking underground storage tank locations on Indian Land.

Date of Government Version: 02/03/2015	Source: EPA Region 1
Date Data Arrived at EDR: 04/30/2015	Telephone: 617-918-1313
Date Made Active in Reports: 06/22/2015	Last EDR Contact: 07/31/2015
Number of Days to Update: 53	Next Scheduled EDR Contact: 11/09/2015
	Data Release Frequency: Varies

### INDIAN LUST R8: Leaking Underground Storage Tanks on Indian Land

LUSTs on Indian land in Colorado, Montana, North Dakota, South Dakota, Utah and Wyoming.

Date of Government Version: 04/30/2015	Source: EPA Region 8
Date Data Arrived at EDR: 05/05/2015	Telephone: 303-312-6271
Date Made Active in Reports: 06/22/2015	Last EDR Contact: 07/22/2015
Number of Days to Update: 48	Next Scheduled EDR Contact: 11/09/2015
	Data Release Frequency: Quarterly

### INDIAN LUST R4: Leaking Underground Storage Tanks on Indian Land

LUSTs on Indian land in Florida, Mississippi and North Carolina.

Date of Government Version: 09/30/2014	Source: EPA Region 4
Date Data Arrived at EDR: 03/03/2015	Telephone: 404-562-8677
Date Made Active in Reports: 03/13/2015	Last EDR Contact: 07/22/2015
Number of Days to Update: 10	Next Scheduled EDR Contact: 11/09/2015
	Data Release Frequency: Semi-Annually

# GOVERNMENT RECORDS SEARCHED / DATA CURRENCY TRACKING

INDIAN LUST R6: Leaking Underground Storage Tanks on Indian Land  
LUSTs on Indian land in New Mexico and Oklahoma.

Date of Government Version: 03/17/2015	Source: EPA Region 6
Date Data Arrived at EDR: 05/01/2015	Telephone: 214-665-6597
Date Made Active in Reports: 06/22/2015	Last EDR Contact: 07/22/2015
Number of Days to Update: 52	Next Scheduled EDR Contact: 11/09/2015
	Data Release Frequency: Varies

INDIAN LUST R7: Leaking Underground Storage Tanks on Indian Land  
LUSTs on Indian land in Iowa, Kansas, and Nebraska

Date of Government Version: 03/30/2015	Source: EPA Region 7
Date Data Arrived at EDR: 04/28/2015	Telephone: 913-551-7003
Date Made Active in Reports: 06/22/2015	Last EDR Contact: 07/22/2015
Number of Days to Update: 55	Next Scheduled EDR Contact: 11/09/2015
	Data Release Frequency: Varies

INDIAN LUST R10: Leaking Underground Storage Tanks on Indian Land  
LUSTs on Indian land in Alaska, Idaho, Oregon and Washington.

Date of Government Version: 02/03/2015	Source: EPA Region 10
Date Data Arrived at EDR: 02/12/2015	Telephone: 206-553-2857
Date Made Active in Reports: 03/13/2015	Last EDR Contact: 07/22/2015
Number of Days to Update: 29	Next Scheduled EDR Contact: 11/09/2015
	Data Release Frequency: Quarterly

INDIAN LUST R9: Leaking Underground Storage Tanks on Indian Land  
LUSTs on Indian land in Arizona, California, New Mexico and Nevada

Date of Government Version: 01/08/2015	Source: Environmental Protection Agency
Date Data Arrived at EDR: 01/08/2015	Telephone: 415-972-3372
Date Made Active in Reports: 02/09/2015	Last EDR Contact: 07/31/2015
Number of Days to Update: 32	Next Scheduled EDR Contact: 11/09/2015
	Data Release Frequency: Quarterly

INDIAN LUST R5: Leaking Underground Storage Tanks on Indian Land  
Leaking underground storage tanks located on Indian Land in Michigan, Minnesota and Wisconsin.

Date of Government Version: 04/30/2015	Source: EPA, Region 5
Date Data Arrived at EDR: 05/29/2015	Telephone: 312-886-7439
Date Made Active in Reports: 06/22/2015	Last EDR Contact: 07/22/2015
Number of Days to Update: 24	Next Scheduled EDR Contact: 11/09/2015
	Data Release Frequency: Varies

## **State and tribal registered storage tank lists**

FEMA UST: Underground Storage Tank Listing  
A listing of all FEMA owned underground storage tanks.

Date of Government Version: 01/01/2010	Source: FEMA
Date Data Arrived at EDR: 02/16/2010	Telephone: 202-646-5797
Date Made Active in Reports: 04/12/2010	Last EDR Contact: 07/10/2015
Number of Days to Update: 55	Next Scheduled EDR Contact: 10/28/2015
	Data Release Frequency: Varies

UST: Underground Storage Tanks

Registered Underground Storage Tanks. UST's are regulated under Subtitle I of the Resource Conservation and Recovery Act (RCRA) and must be registered with the state department responsible for administering the UST program. Available information varies by state program.

# GOVERNMENT RECORDS SEARCHED / DATA CURRENCY TRACKING

Date of Government Version: 06/24/2015  
Date Data Arrived at EDR: 06/29/2015  
Date Made Active in Reports: 07/20/2015  
Number of Days to Update: 21

Source: Department of Environmental Quality  
Telephone: 601-961-5058  
Last EDR Contact: 06/29/2015  
Next Scheduled EDR Contact: 10/12/2015  
Data Release Frequency: Quarterly

## AST: Aboveground Storage Tanks

Aboveground storage tanks regulated by the Department of Agriculture & Commerce. The tanks contents will be gasoline, diesel, racing fuel or kerosene.

Date of Government Version: 06/09/2015  
Date Data Arrived at EDR: 06/11/2015  
Date Made Active in Reports: 07/20/2015  
Number of Days to Update: 39

Source: Department of Agriculture & Commerce  
Telephone: 601-359-1101  
Last EDR Contact: 05/26/2015  
Next Scheduled EDR Contact: 09/07/2015  
Data Release Frequency: Semi-Annually

## INDIAN UST R4: Underground Storage Tanks on Indian Land

The Indian Underground Storage Tank (UST) database provides information about underground storage tanks on Indian land in EPA Region 4 (Alabama, Florida, Georgia, Kentucky, Mississippi, North Carolina, South Carolina, Tennessee and Tribal Nations)

Date of Government Version: 09/30/2014  
Date Data Arrived at EDR: 03/03/2015  
Date Made Active in Reports: 03/13/2015  
Number of Days to Update: 10

Source: EPA Region 4  
Telephone: 404-562-9424  
Last EDR Contact: 07/22/2015  
Next Scheduled EDR Contact: 11/09/2015  
Data Release Frequency: Semi-Annually

## INDIAN UST R9: Underground Storage Tanks on Indian Land

The Indian Underground Storage Tank (UST) database provides information about underground storage tanks on Indian land in EPA Region 9 (Arizona, California, Hawaii, Nevada, the Pacific Islands, and Tribal Nations).

Date of Government Version: 12/14/2014  
Date Data Arrived at EDR: 02/13/2015  
Date Made Active in Reports: 03/13/2015  
Number of Days to Update: 28

Source: EPA Region 9  
Telephone: 415-972-3368  
Last EDR Contact: 07/31/2015  
Next Scheduled EDR Contact: 11/09/2015  
Data Release Frequency: Quarterly

## INDIAN UST R7: Underground Storage Tanks on Indian Land

The Indian Underground Storage Tank (UST) database provides information about underground storage tanks on Indian land in EPA Region 7 (Iowa, Kansas, Missouri, Nebraska, and 9 Tribal Nations).

Date of Government Version: 09/23/2014  
Date Data Arrived at EDR: 11/25/2014  
Date Made Active in Reports: 01/29/2015  
Number of Days to Update: 65

Source: EPA Region 7  
Telephone: 913-551-7003  
Last EDR Contact: 07/22/2015  
Next Scheduled EDR Contact: 11/09/2015  
Data Release Frequency: Varies

## INDIAN UST R6: Underground Storage Tanks on Indian Land

The Indian Underground Storage Tank (UST) database provides information about underground storage tanks on Indian land in EPA Region 6 (Louisiana, Arkansas, Oklahoma, New Mexico, Texas and 65 Tribes).

Date of Government Version: 03/17/2015  
Date Data Arrived at EDR: 05/01/2015  
Date Made Active in Reports: 06/22/2015  
Number of Days to Update: 52

Source: EPA Region 6  
Telephone: 214-665-7591  
Last EDR Contact: 07/22/2015  
Next Scheduled EDR Contact: 11/09/2015  
Data Release Frequency: Semi-Annually

## INDIAN UST R5: Underground Storage Tanks on Indian Land

The Indian Underground Storage Tank (UST) database provides information about underground storage tanks on Indian land in EPA Region 5 (Michigan, Minnesota and Wisconsin and Tribal Nations).

# GOVERNMENT RECORDS SEARCHED / DATA CURRENCY TRACKING

Date of Government Version: 04/30/2015  
Date Data Arrived at EDR: 05/26/2015  
Date Made Active in Reports: 06/22/2015  
Number of Days to Update: 27

Source: EPA Region 5  
Telephone: 312-886-6136  
Last EDR Contact: 07/22/2015  
Next Scheduled EDR Contact: 11/09/2015  
Data Release Frequency: Varies

## INDIAN UST R8: Underground Storage Tanks on Indian Land

The Indian Underground Storage Tank (UST) database provides information about underground storage tanks on Indian land in EPA Region 8 (Colorado, Montana, North Dakota, South Dakota, Utah, Wyoming and 27 Tribal Nations).

Date of Government Version: 04/30/2015  
Date Data Arrived at EDR: 05/05/2015  
Date Made Active in Reports: 06/22/2015  
Number of Days to Update: 48

Source: EPA Region 8  
Telephone: 303-312-6137  
Last EDR Contact: 07/22/2015  
Next Scheduled EDR Contact: 11/09/2015  
Data Release Frequency: Quarterly

## INDIAN UST R10: Underground Storage Tanks on Indian Land

The Indian Underground Storage Tank (UST) database provides information about underground storage tanks on Indian land in EPA Region 10 (Alaska, Idaho, Oregon, Washington, and Tribal Nations).

Date of Government Version: 05/06/2015  
Date Data Arrived at EDR: 05/19/2015  
Date Made Active in Reports: 06/22/2015  
Number of Days to Update: 34

Source: EPA Region 10  
Telephone: 206-553-2857  
Last EDR Contact: 07/22/2015  
Next Scheduled EDR Contact: 11/09/2015  
Data Release Frequency: Quarterly

## INDIAN UST R1: Underground Storage Tanks on Indian Land

The Indian Underground Storage Tank (UST) database provides information about underground storage tanks on Indian land in EPA Region 1 (Connecticut, Maine, Massachusetts, New Hampshire, Rhode Island, Vermont and ten Tribal Nations).

Date of Government Version: 02/03/2015  
Date Data Arrived at EDR: 04/30/2015  
Date Made Active in Reports: 06/22/2015  
Number of Days to Update: 53

Source: EPA, Region 1  
Telephone: 617-918-1313  
Last EDR Contact: 07/31/2015  
Next Scheduled EDR Contact: 11/09/2015  
Data Release Frequency: Varies

## ***State and tribal institutional control / engineering control registries***

### ENG CONTROLS: Sites with Engineering Controls

Sites included on the CERCLA/Uncontrolled Sites File List that have Engineering Controls. Engineering Controls encompass a variety of engineered remedies to contain and/or reduce contamination, and/or physical barriers intended to limit access to property. ECs include fences, signs, guards, landfill caps, provision of potable water, slurry walls, sheet pile (vertical caps), pumping and treatment of groundwater, monitoring wells, and vapor extraction systems

Date of Government Version: 06/15/2015  
Date Data Arrived at EDR: 06/29/2015  
Date Made Active in Reports: 07/20/2015  
Number of Days to Update: 21

Source: Department of Environmental Quality  
Telephone: 601-961-5666  
Last EDR Contact: 06/27/2015  
Next Scheduled EDR Contact: 10/12/2015  
Data Release Frequency: Quarterly

### INST CONTROL: Sites with Institutional Controls

Sites included on the CERCLA/Uncontrolled Sites File List that have Institutional Controls. Institutional Controls are non-engineered instruments, such as administrative and/or legal controls, that help minimize the potential for human exposure to contamination and/or protect the integrity of a remedy by limiting land or resource use

Date of Government Version: 06/15/2015  
Date Data Arrived at EDR: 06/29/2015  
Date Made Active in Reports: 07/20/2015  
Number of Days to Update: 21

Source: Department of Environmental Quality  
Telephone: 601-961-5666  
Last EDR Contact: 06/27/2015  
Next Scheduled EDR Contact: 10/12/2015  
Data Release Frequency: Quarterly

# GOVERNMENT RECORDS SEARCHED / DATA CURRENCY TRACKING

## **State and tribal voluntary cleanup sites**

### INDIAN VCP R1: Voluntary Cleanup Priority Listing

A listing of voluntary cleanup priority sites located on Indian Land located in Region 1.

Date of Government Version: 09/29/2014	Source: EPA, Region 1
Date Data Arrived at EDR: 10/01/2014	Telephone: 617-918-1102
Date Made Active in Reports: 11/06/2014	Last EDR Contact: 06/26/2015
Number of Days to Update: 36	Next Scheduled EDR Contact: 10/12/2015
	Data Release Frequency: Varies

### INDIAN VCP R7: Voluntary Cleanup Priority Listing

A listing of voluntary cleanup priority sites located on Indian Land located in Region 7.

Date of Government Version: 03/20/2008	Source: EPA, Region 7
Date Data Arrived at EDR: 04/22/2008	Telephone: 913-551-7365
Date Made Active in Reports: 05/19/2008	Last EDR Contact: 04/20/2009
Number of Days to Update: 27	Next Scheduled EDR Contact: 07/20/2009
	Data Release Frequency: Varies

### VCP: Voluntary Evaluation Program Sites

The Voluntary Evaluation Program allows accepted parties the opportunity to participate in a program that will expedite the evaluation of the site information.

Date of Government Version: 06/15/2015	Source: Department of Environmental Quality
Date Data Arrived at EDR: 06/29/2015	Telephone: 601-961-5063
Date Made Active in Reports: 07/20/2015	Last EDR Contact: 06/27/2015
Number of Days to Update: 21	Next Scheduled EDR Contact: 10/12/2015
	Data Release Frequency: Varies

## **State and tribal Brownfields sites**

### BROWNFIELDS: Uncontrolled Sites List

A listing of sites from the Uncontrolled Sites List that are currently in the Mississippi Brownfields Program (which means that they are pursuing liability protection and paying for MDEQ oversight costs).

Date of Government Version: 06/15/2015	Source: Department of Environmental Quality
Date Data Arrived at EDR: 06/29/2015	Telephone: 601-961-5666
Date Made Active in Reports: 07/20/2015	Last EDR Contact: 06/27/2015
Number of Days to Update: 21	Next Scheduled EDR Contact: 10/12/2015
	Data Release Frequency: Varies

## **ADDITIONAL ENVIRONMENTAL RECORDS**

### **Local Brownfield lists**

#### US BROWNFIELDS: A Listing of Brownfields Sites

Brownfields are real property, the expansion, redevelopment, or reuse of which may be complicated by the presence or potential presence of a hazardous substance, pollutant, or contaminant. Cleaning up and reinvesting in these properties takes development pressures off of undeveloped, open land, and both improves and protects the environment. Assessment, Cleanup and Redevelopment Exchange System (ACRES) stores information reported by EPA Brownfields grant recipients on brownfields properties assessed or cleaned up with grant funding as well as information on Targeted Brownfields Assessments performed by EPA Regions. A listing of ACRES Brownfield sites is obtained from Cleanups in My Community. Cleanups in My Community provides information on Brownfields properties for which information is reported back to EPA, as well as areas served by Brownfields grant programs.

Date of Government Version: 06/22/2015	Source: Environmental Protection Agency
Date Data Arrived at EDR: 06/24/2015	Telephone: 202-566-2777
Date Made Active in Reports: 09/02/2015	Last EDR Contact: 06/24/2015
Number of Days to Update: 70	Next Scheduled EDR Contact: 10/05/2015
	Data Release Frequency: Semi-Annually

# GOVERNMENT RECORDS SEARCHED / DATA CURRENCY TRACKING

## **Local Lists of Landfill / Solid Waste Disposal Sites**

### **SWTIRE: Commercial Waste Tire Haulers**

A listing of commercial waste tire haulers.

Date of Government Version: 08/09/2015

Date Data Arrived at EDR: 08/10/2015

Date Made Active in Reports: 09/04/2015

Number of Days to Update: 25

Source: Department of Environmental Quality

Telephone: 601-961-5726

Last EDR Contact: 08/06/2015

Next Scheduled EDR Contact: 11/23/2015

Data Release Frequency: Quarterly

### **SWRCY: Mississippi Recycling Directory**

A listing of recycling facilities.

Date of Government Version: 12/31/2013

Date Data Arrived at EDR: 05/30/2014

Date Made Active in Reports: 06/25/2014

Number of Days to Update: 26

Source: Department of Environmental Quality

Telephone: 601-961-5005

Last EDR Contact: 05/29/2015

Next Scheduled EDR Contact: 09/07/2015

Data Release Frequency: Varies

### **INDIAN ODI: Report on the Status of Open Dumps on Indian Lands**

Location of open dumps on Indian land.

Date of Government Version: 12/31/1998

Date Data Arrived at EDR: 12/03/2007

Date Made Active in Reports: 01/24/2008

Number of Days to Update: 52

Source: Environmental Protection Agency

Telephone: 703-308-8245

Last EDR Contact: 05/01/2015

Next Scheduled EDR Contact: 08/17/2015

Data Release Frequency: Varies

### **DEBRIS REGION 9: Torres Martinez Reservation Illegal Dump Site Locations**

A listing of illegal dump sites location on the Torres Martinez Indian Reservation located in eastern Riverside County and northern Imperial County, California.

Date of Government Version: 01/12/2009

Date Data Arrived at EDR: 05/07/2009

Date Made Active in Reports: 09/21/2009

Number of Days to Update: 137

Source: EPA, Region 9

Telephone: 415-947-4219

Last EDR Contact: 07/22/2015

Next Scheduled EDR Contact: 11/09/2015

Data Release Frequency: No Update Planned

### **ODI: Open Dump Inventory**

An open dump is defined as a disposal facility that does not comply with one or more of the Part 257 or Part 258 Subtitle D Criteria.

Date of Government Version: 06/30/1985

Date Data Arrived at EDR: 08/09/2004

Date Made Active in Reports: 09/17/2004

Number of Days to Update: 39

Source: Environmental Protection Agency

Telephone: 800-424-9346

Last EDR Contact: 06/09/2004

Next Scheduled EDR Contact: N/A

Data Release Frequency: No Update Planned

## **Local Lists of Hazardous waste / Contaminated Sites**

### **US HIST CDL: National Clandestine Laboratory Register**

A listing of clandestine drug lab locations. The U.S. Department of Justice ("the Department") provides this web site as a public service. It contains addresses of some locations where law enforcement agencies reported they found chemicals or other items that indicated the presence of either clandestine drug laboratories or dumpsites. In most cases, the source of the entries is not the Department, and the Department has not verified the entry and does not guarantee its accuracy. Members of the public must verify the accuracy of all entries by, for example, contacting local law enforcement and local health departments.

# GOVERNMENT RECORDS SEARCHED / DATA CURRENCY TRACKING

Date of Government Version: 02/25/2015  
Date Data Arrived at EDR: 03/10/2015  
Date Made Active in Reports: 03/25/2015  
Number of Days to Update: 15

Source: Drug Enforcement Administration  
Telephone: 202-307-1000  
Last EDR Contact: 05/29/2015  
Next Scheduled EDR Contact: 09/14/2015  
Data Release Frequency: No Update Planned

## US CDL: Clandestine Drug Labs

A listing of clandestine drug lab locations. The U.S. Department of Justice ("the Department") provides this web site as a public service. It contains addresses of some locations where law enforcement agencies reported they found chemicals or other items that indicated the presence of either clandestine drug laboratories or dumpsites. In most cases, the source of the entries is not the Department, and the Department has not verified the entry and does not guarantee its accuracy. Members of the public must verify the accuracy of all entries by, for example, contacting local law enforcement and local health departments.

Date of Government Version: 02/25/2015  
Date Data Arrived at EDR: 03/10/2015  
Date Made Active in Reports: 03/25/2015  
Number of Days to Update: 15

Source: Drug Enforcement Administration  
Telephone: 202-307-1000  
Last EDR Contact: 05/29/2015  
Next Scheduled EDR Contact: 09/14/2015  
Data Release Frequency: Quarterly

## Local Land Records

### LIENS 2: CERCLA Lien Information

A Federal CERCLA ("Superfund") lien can exist by operation of law at any site or property at which EPA has spent Superfund monies. These monies are spent to investigate and address releases and threatened releases of contamination. CERCLIS provides information as to the identity of these sites and properties.

Date of Government Version: 02/18/2014  
Date Data Arrived at EDR: 03/18/2014  
Date Made Active in Reports: 04/24/2014  
Number of Days to Update: 37

Source: Environmental Protection Agency  
Telephone: 202-564-6023  
Last EDR Contact: 07/22/2015  
Next Scheduled EDR Contact: 11/09/2015  
Data Release Frequency: Varies

## Records of Emergency Release Reports

### HMIRS: Hazardous Materials Information Reporting System

Hazardous Materials Incident Report System. HMIRS contains hazardous material spill incidents reported to DOT.

Date of Government Version: 06/24/2015  
Date Data Arrived at EDR: 06/26/2015  
Date Made Active in Reports: 09/02/2015  
Number of Days to Update: 68

Source: U.S. Department of Transportation  
Telephone: 202-366-4555  
Last EDR Contact: 06/26/2015  
Next Scheduled EDR Contact: 10/12/2015  
Data Release Frequency: Annually

## Other Ascertainable Records

### RCRA NonGen / NLR: RCRA - Non Generators / No Longer Regulated

RCRAInfo is EPA's comprehensive information system, providing access to data supporting the Resource Conservation and Recovery Act (RCRA) of 1976 and the Hazardous and Solid Waste Amendments (HSWA) of 1984. The database includes selective information on sites which generate, transport, store, treat and/or dispose of hazardous waste as defined by the Resource Conservation and Recovery Act (RCRA). Non-Generators do not presently generate hazardous waste.

Date of Government Version: 03/10/2015  
Date Data Arrived at EDR: 03/31/2015  
Date Made Active in Reports: 06/11/2015  
Number of Days to Update: 72

Source: Environmental Protection Agency  
Telephone: (404) 562-8651  
Last EDR Contact: 06/26/2015  
Next Scheduled EDR Contact: 10/12/2015  
Data Release Frequency: Varies



# GOVERNMENT RECORDS SEARCHED / DATA CURRENCY TRACKING

## FUDS: Formerly Used Defense Sites

The listing includes locations of Formerly Used Defense Sites properties where the US Army Corps of Engineers is actively working or will take necessary cleanup actions.

Date of Government Version: 06/06/2014	Source: U.S. Army Corps of Engineers
Date Data Arrived at EDR: 09/10/2014	Telephone: 202-528-4285
Date Made Active in Reports: 09/18/2014	Last EDR Contact: 07/08/2015
Number of Days to Update: 8	Next Scheduled EDR Contact: 09/21/2015
	Data Release Frequency: Varies

## DOD: Department of Defense Sites

This data set consists of federally owned or administered lands, administered by the Department of Defense, that have any area equal to or greater than 640 acres of the United States, Puerto Rico, and the U.S. Virgin Islands.

Date of Government Version: 12/31/2005	Source: USGS
Date Data Arrived at EDR: 11/10/2006	Telephone: 888-275-8747
Date Made Active in Reports: 01/11/2007	Last EDR Contact: 07/14/2015
Number of Days to Update: 62	Next Scheduled EDR Contact: 10/28/2015
	Data Release Frequency: Semi-Annually

## FEDLAND: Federal and Indian Lands

Federally and Indian administrated lands of the United States. Lands included are administrated by: Army Corps of Engineers, Bureau of Reclamation, National Wild and Scenic River, National Wildlife Refuge, Public Domain Land, Wilderness, Wilderness Study Area, Wildlife Management Area, Bureau of Indian Affairs, Bureau of Land Management, Department of Justice, Forest Service, Fish and Wildlife Service, National Park Service.

Date of Government Version: 12/31/2005	Source: U.S. Geological Survey
Date Data Arrived at EDR: 02/06/2006	Telephone: 888-275-8747
Date Made Active in Reports: 01/11/2007	Last EDR Contact: 07/14/2015
Number of Days to Update: 339	Next Scheduled EDR Contact: 10/28/2015
	Data Release Frequency: N/A

## SCRD DRYCLEANERS: State Coalition for Remediation of Drycleaners Listing

The State Coalition for Remediation of Drycleaners was established in 1998, with support from the U.S. EPA Office of Superfund Remediation and Technology Innovation. It is comprised of representatives of states with established drycleaner remediation programs. Currently the member states are Alabama, Connecticut, Florida, Illinois, Kansas, Minnesota, Missouri, North Carolina, Oregon, South Carolina, Tennessee, Texas, and Wisconsin.

Date of Government Version: 03/07/2011	Source: Environmental Protection Agency
Date Data Arrived at EDR: 03/09/2011	Telephone: 615-532-8599
Date Made Active in Reports: 05/02/2011	Last EDR Contact: 05/21/2015
Number of Days to Update: 54	Next Scheduled EDR Contact: 08/31/2015
	Data Release Frequency: Varies

## US FIN ASSUR: Financial Assurance Information

All owners and operators of facilities that treat, store, or dispose of hazardous waste are required to provide proof that they will have sufficient funds to pay for the clean up, closure, and post-closure care of their facilities.

Date of Government Version: 03/09/2015	Source: Environmental Protection Agency
Date Data Arrived at EDR: 03/10/2015	Telephone: 202-566-1917
Date Made Active in Reports: 03/25/2015	Last EDR Contact: 08/12/2015
Number of Days to Update: 15	Next Scheduled EDR Contact: 11/30/2015
	Data Release Frequency: Quarterly

## EPA WATCH LIST: EPA WATCH LIST

EPA maintains a "Watch List" to facilitate dialogue between EPA, state and local environmental agencies on enforcement matters relating to facilities with alleged violations identified as either significant or high priority. Being on the Watch List does not mean that the facility has actually violated the law only that an investigation by EPA or a state or local environmental agency has led those organizations to allege that an unproven violation has in fact occurred. Being on the Watch List does not represent a higher level of concern regarding the alleged violations that were detected, but instead indicates cases requiring additional dialogue between EPA, state and local agencies - primarily because of the length of time the alleged violation has gone unaddressed or unresolved.

# GOVERNMENT RECORDS SEARCHED / DATA CURRENCY TRACKING

Date of Government Version: 08/30/2013  
Date Data Arrived at EDR: 03/21/2014  
Date Made Active in Reports: 06/17/2014  
Number of Days to Update: 88

Source: Environmental Protection Agency  
Telephone: 617-520-3000  
Last EDR Contact: 08/04/2015  
Next Scheduled EDR Contact: 11/23/2015  
Data Release Frequency: Quarterly

## 2020 COR ACTION: 2020 Corrective Action Program List

The EPA has set ambitious goals for the RCRA Corrective Action program by creating the 2020 Corrective Action Universe. This RCRA cleanup baseline includes facilities expected to need corrective action. The 2020 universe contains a wide variety of sites. Some properties are heavily contaminated while others were contaminated but have since been cleaned up. Still others have not been fully investigated yet, and may require little or no remediation. Inclusion in the 2020 Universe does not necessarily imply failure on the part of a facility to meet its RCRA obligations.

Date of Government Version: 04/22/2013  
Date Data Arrived at EDR: 03/03/2015  
Date Made Active in Reports: 03/09/2015  
Number of Days to Update: 6

Source: Environmental Protection Agency  
Telephone: 703-308-4044  
Last EDR Contact: 05/14/2015  
Next Scheduled EDR Contact: 08/24/2015  
Data Release Frequency: Varies

## TSCA: Toxic Substances Control Act

Toxic Substances Control Act. TSCA identifies manufacturers and importers of chemical substances included on the TSCA Chemical Substance Inventory list. It includes data on the production volume of these substances by plant site.

Date of Government Version: 12/31/2012  
Date Data Arrived at EDR: 01/15/2015  
Date Made Active in Reports: 01/29/2015  
Number of Days to Update: 14

Source: EPA  
Telephone: 202-260-5521  
Last EDR Contact: 06/25/2015  
Next Scheduled EDR Contact: 10/05/2015  
Data Release Frequency: Every 4 Years

## TRIS: Toxic Chemical Release Inventory System

Toxic Release Inventory System. TRIS identifies facilities which release toxic chemicals to the air, water and land in reportable quantities under SARA Title III Section 313.

Date of Government Version: 12/31/2013  
Date Data Arrived at EDR: 02/12/2015  
Date Made Active in Reports: 06/02/2015  
Number of Days to Update: 110

Source: EPA  
Telephone: 202-566-0250  
Last EDR Contact: 01/29/2015  
Next Scheduled EDR Contact: 06/08/2015  
Data Release Frequency: Annually

## SSTS: Section 7 Tracking Systems

Section 7 of the Federal Insecticide, Fungicide and Rodenticide Act, as amended (92 Stat. 829) requires all registered pesticide-producing establishments to submit a report to the Environmental Protection Agency by March 1st each year. Each establishment must report the types and amounts of pesticides, active ingredients and devices being produced, and those having been produced and sold or distributed in the past year.

Date of Government Version: 12/31/2009  
Date Data Arrived at EDR: 12/10/2010  
Date Made Active in Reports: 02/25/2011  
Number of Days to Update: 77

Source: EPA  
Telephone: 202-564-4203  
Last EDR Contact: 07/22/2015  
Next Scheduled EDR Contact: 11/09/2015  
Data Release Frequency: Annually

## ROD: Records Of Decision

Record of Decision. ROD documents mandate a permanent remedy at an NPL (Superfund) site containing technical and health information to aid in the cleanup.

Date of Government Version: 11/25/2013  
Date Data Arrived at EDR: 12/12/2013  
Date Made Active in Reports: 02/24/2014  
Number of Days to Update: 74

Source: EPA  
Telephone: 703-416-0223  
Last EDR Contact: 06/12/2015  
Next Scheduled EDR Contact: 09/21/2015  
Data Release Frequency: Annually

# GOVERNMENT RECORDS SEARCHED / DATA CURRENCY TRACKING

## RMP: Risk Management Plans

When Congress passed the Clean Air Act Amendments of 1990, it required EPA to publish regulations and guidance for chemical accident prevention at facilities using extremely hazardous substances. The Risk Management Program Rule (RMP Rule) was written to implement Section 112(r) of these amendments. The rule, which built upon existing industry codes and standards, requires companies of all sizes that use certain flammable and toxic substances to develop a Risk Management Program, which includes a(n): Hazard assessment that details the potential effects of an accidental release, an accident history of the last five years, and an evaluation of worst-case and alternative accidental releases; Prevention program that includes safety precautions and maintenance, monitoring, and employee training measures; and Emergency response program that spells out emergency health care, employee training measures and procedures for informing the public and response agencies (e.g the fire department) should an accident occur.

Date of Government Version: 02/01/2015	Source: Environmental Protection Agency
Date Data Arrived at EDR: 02/13/2015	Telephone: 202-564-8600
Date Made Active in Reports: 03/25/2015	Last EDR Contact: 07/22/2015
Number of Days to Update: 40	Next Scheduled EDR Contact: 11/09/2015
	Data Release Frequency: Varies

## RAATS: RCRA Administrative Action Tracking System

RCRA Administration Action Tracking System. RAATS contains records based on enforcement actions issued under RCRA pertaining to major violators and includes administrative and civil actions brought by the EPA. For administration actions after September 30, 1995, data entry in the RAATS database was discontinued. EPA will retain a copy of the database for historical records. It was necessary to terminate RAATS because a decrease in agency resources made it impossible to continue to update the information contained in the database.

Date of Government Version: 04/17/1995	Source: EPA
Date Data Arrived at EDR: 07/03/1995	Telephone: 202-564-4104
Date Made Active in Reports: 08/07/1995	Last EDR Contact: 06/02/2008
Number of Days to Update: 35	Next Scheduled EDR Contact: 09/01/2008
	Data Release Frequency: No Update Planned

## PRP: Potentially Responsible Parties

A listing of verified Potentially Responsible Parties

Date of Government Version: 10/25/2013	Source: EPA
Date Data Arrived at EDR: 10/17/2014	Telephone: 202-564-6023
Date Made Active in Reports: 10/20/2014	Last EDR Contact: 05/14/2015
Number of Days to Update: 3	Next Scheduled EDR Contact: 08/24/2015
	Data Release Frequency: Quarterly

## PADS: PCB Activity Database System

PCB Activity Database. PADS Identifies generators, transporters, commercial storers and/or brokers and disposers of PCB's who are required to notify the EPA of such activities.

Date of Government Version: 07/01/2014	Source: EPA
Date Data Arrived at EDR: 10/15/2014	Telephone: 202-566-0500
Date Made Active in Reports: 11/17/2014	Last EDR Contact: 07/17/2015
Number of Days to Update: 33	Next Scheduled EDR Contact: 10/28/2015
	Data Release Frequency: Annually

## ICIS: Integrated Compliance Information System

The Integrated Compliance Information System (ICIS) supports the information needs of the national enforcement and compliance program as well as the unique needs of the National Pollutant Discharge Elimination System (NPDES) program.

Date of Government Version: 01/23/2015	Source: Environmental Protection Agency
Date Data Arrived at EDR: 02/06/2015	Telephone: 202-564-5088
Date Made Active in Reports: 03/09/2015	Last EDR Contact: 07/09/2015
Number of Days to Update: 31	Next Scheduled EDR Contact: 10/28/2015
	Data Release Frequency: Quarterly

## GOVERNMENT RECORDS SEARCHED / DATA CURRENCY TRACKING

### FTTS: FIFRA/ TSCA Tracking System - FIFRA (Federal Insecticide, Fungicide, & Rodenticide Act)/TSCA (Toxic Substances Control Act)

FTTS tracks administrative cases and pesticide enforcement actions and compliance activities related to FIFRA, TSCA and EPCRA (Emergency Planning and Community Right-to-Know Act). To maintain currency, EDR contacts the Agency on a quarterly basis.

Date of Government Version: 04/09/2009  
Date Data Arrived at EDR: 04/16/2009  
Date Made Active in Reports: 05/11/2009  
Number of Days to Update: 25

Source: EPA/Office of Prevention, Pesticides and Toxic Substances  
Telephone: 202-566-1667  
Last EDR Contact: 05/20/2015  
Next Scheduled EDR Contact: 09/07/2015  
Data Release Frequency: Quarterly

### FTTS INSP: FIFRA/ TSCA Tracking System - FIFRA (Federal Insecticide, Fungicide, & Rodenticide Act)/TSCA (Toxic Substances Control Act)

A listing of FIFRA/TSCA Tracking System (FTTS) inspections and enforcements.

Date of Government Version: 04/09/2009  
Date Data Arrived at EDR: 04/16/2009  
Date Made Active in Reports: 05/11/2009  
Number of Days to Update: 25

Source: EPA  
Telephone: 202-566-1667  
Last EDR Contact: 05/20/2015  
Next Scheduled EDR Contact: 09/07/2015  
Data Release Frequency: Quarterly

### MLTS: Material Licensing Tracking System

MLTS is maintained by the Nuclear Regulatory Commission and contains a list of approximately 8,100 sites which possess or use radioactive materials and which are subject to NRC licensing requirements. To maintain currency, EDR contacts the Agency on a quarterly basis.

Date of Government Version: 03/31/2015  
Date Data Arrived at EDR: 04/09/2015  
Date Made Active in Reports: 06/11/2015  
Number of Days to Update: 63

Source: Nuclear Regulatory Commission  
Telephone: 301-415-7169  
Last EDR Contact: 06/04/2015  
Next Scheduled EDR Contact: 09/21/2015  
Data Release Frequency: Quarterly

### COAL ASH DOE: Steam-Electric Plant Operation Data

A listing of power plants that store ash in surface ponds.

Date of Government Version: 12/31/2005  
Date Data Arrived at EDR: 08/07/2009  
Date Made Active in Reports: 10/22/2009  
Number of Days to Update: 76

Source: Department of Energy  
Telephone: 202-586-8719  
Last EDR Contact: 07/13/2015  
Next Scheduled EDR Contact: 10/28/2015  
Data Release Frequency: Varies

### COAL ASH EPA: Coal Combustion Residues Surface Impoundments List

A listing of coal combustion residues surface impoundments with high hazard potential ratings.

Date of Government Version: 07/01/2014  
Date Data Arrived at EDR: 09/10/2014  
Date Made Active in Reports: 10/20/2014  
Number of Days to Update: 40

Source: Environmental Protection Agency  
Telephone: N/A  
Last EDR Contact: 06/12/2015  
Next Scheduled EDR Contact: 09/21/2015  
Data Release Frequency: Varies

### PCB TRANSFORMER: PCB Transformer Registration Database

The database of PCB transformer registrations that includes all PCB registration submittals.

Date of Government Version: 02/01/2011  
Date Data Arrived at EDR: 10/19/2011  
Date Made Active in Reports: 01/10/2012  
Number of Days to Update: 83

Source: Environmental Protection Agency  
Telephone: 202-566-0517  
Last EDR Contact: 07/31/2015  
Next Scheduled EDR Contact: 11/09/2015  
Data Release Frequency: Varies

### RADINFO: Radiation Information Database

The Radiation Information Database (RADINFO) contains information about facilities that are regulated by U.S. Environmental Protection Agency (EPA) regulations for radiation and radioactivity.

# GOVERNMENT RECORDS SEARCHED / DATA CURRENCY TRACKING

Date of Government Version: 04/07/2015  
Date Data Arrived at EDR: 04/09/2015  
Date Made Active in Reports: 06/11/2015  
Number of Days to Update: 63

Source: Environmental Protection Agency  
Telephone: 202-343-9775  
Last EDR Contact: 07/09/2015  
Next Scheduled EDR Contact: 10/19/2015  
Data Release Frequency: Quarterly

## HIST FTTS: FIFRA/TSCA Tracking System Administrative Case Listing

A complete administrative case listing from the FIFRA/TSCA Tracking System (FTTS) for all ten EPA regions. The information was obtained from the National Compliance Database (NCDB). NCDB supports the implementation of FIFRA (Federal Insecticide, Fungicide, and Rodenticide Act) and TSCA (Toxic Substances Control Act). Some EPA regions are now closing out records. Because of that, and the fact that some EPA regions are not providing EPA Headquarters with updated records, it was decided to create a HIST FTTS database. It included records that may not be included in the newer FTTS database updates. This database is no longer updated.

Date of Government Version: 10/19/2006  
Date Data Arrived at EDR: 03/01/2007  
Date Made Active in Reports: 04/10/2007  
Number of Days to Update: 40

Source: Environmental Protection Agency  
Telephone: 202-564-2501  
Last EDR Contact: 12/17/2007  
Next Scheduled EDR Contact: 03/17/2008  
Data Release Frequency: No Update Planned

## HIST FTTS INSP: FIFRA/TSCA Tracking System Inspection & Enforcement Case Listing

A complete inspection and enforcement case listing from the FIFRA/TSCA Tracking System (FTTS) for all ten EPA regions. The information was obtained from the National Compliance Database (NCDB). NCDB supports the implementation of FIFRA (Federal Insecticide, Fungicide, and Rodenticide Act) and TSCA (Toxic Substances Control Act). Some EPA regions are now closing out records. Because of that, and the fact that some EPA regions are not providing EPA Headquarters with updated records, it was decided to create a HIST FTTS database. It included records that may not be included in the newer FTTS database updates. This database is no longer updated.

Date of Government Version: 10/19/2006  
Date Data Arrived at EDR: 03/01/2007  
Date Made Active in Reports: 04/10/2007  
Number of Days to Update: 40

Source: Environmental Protection Agency  
Telephone: 202-564-2501  
Last EDR Contact: 12/17/2008  
Next Scheduled EDR Contact: 03/17/2008  
Data Release Frequency: No Update Planned

## DOT OPS: Incident and Accident Data

Department of Transportation, Office of Pipeline Safety Incident and Accident data.

Date of Government Version: 07/31/2012  
Date Data Arrived at EDR: 08/07/2012  
Date Made Active in Reports: 09/18/2012  
Number of Days to Update: 42

Source: Department of Transportation, Office of Pipeline Safety  
Telephone: 202-366-4595  
Last EDR Contact: 08/04/2015  
Next Scheduled EDR Contact: 11/16/2015  
Data Release Frequency: Varies

## CONSENT: Superfund (CERCLA) Consent Decrees

Major legal settlements that establish responsibility and standards for cleanup at NPL (Superfund) sites. Released periodically by United States District Courts after settlement by parties to litigation matters.

Date of Government Version: 12/31/2014  
Date Data Arrived at EDR: 04/17/2015  
Date Made Active in Reports: 06/02/2015  
Number of Days to Update: 46

Source: Department of Justice, Consent Decree Library  
Telephone: Varies  
Last EDR Contact: 06/22/2015  
Next Scheduled EDR Contact: 10/12/2015  
Data Release Frequency: Varies

## BRS: Biennial Reporting System

The Biennial Reporting System is a national system administered by the EPA that collects data on the generation and management of hazardous waste. BRS captures detailed data from two groups: Large Quantity Generators (LQG) and Treatment, Storage, and Disposal Facilities.

Date of Government Version: 12/31/2011  
Date Data Arrived at EDR: 02/26/2013  
Date Made Active in Reports: 04/19/2013  
Number of Days to Update: 52

Source: EPA/NTIS  
Telephone: 800-424-9346  
Last EDR Contact: 05/29/2015  
Next Scheduled EDR Contact: 09/07/2015  
Data Release Frequency: Biennially

# GOVERNMENT RECORDS SEARCHED / DATA CURRENCY TRACKING

## INDIAN RESERV: Indian Reservations

This map layer portrays Indian administered lands of the United States that have any area equal to or greater than 640 acres.

Date of Government Version: 12/31/2005	Source: USGS
Date Data Arrived at EDR: 12/08/2006	Telephone: 202-208-3710
Date Made Active in Reports: 01/11/2007	Last EDR Contact: 07/14/2015
Number of Days to Update: 34	Next Scheduled EDR Contact: 10/28/2015
	Data Release Frequency: Semi-Annually

## UMTRA: Uranium Mill Tailings Sites

Uranium ore was mined by private companies for federal government use in national defense programs. When the mills shut down, large piles of the sand-like material (mill tailings) remain after uranium has been extracted from the ore. Levels of human exposure to radioactive materials from the piles are low; however, in some cases tailings were used as construction materials before the potential health hazards of the tailings were recognized.

Date of Government Version: 09/14/2010	Source: Department of Energy
Date Data Arrived at EDR: 10/07/2011	Telephone: 505-845-0011
Date Made Active in Reports: 03/01/2012	Last EDR Contact: 05/26/2015
Number of Days to Update: 146	Next Scheduled EDR Contact: 09/07/2015
	Data Release Frequency: Varies

## LEAD SMELTER 1: Lead Smelter Sites

A listing of former lead smelter site locations.

Date of Government Version: 11/25/2014	Source: Environmental Protection Agency
Date Data Arrived at EDR: 11/26/2014	Telephone: 703-603-8787
Date Made Active in Reports: 01/29/2015	Last EDR Contact: 07/07/2015
Number of Days to Update: 64	Next Scheduled EDR Contact: 10/19/2015
	Data Release Frequency: Varies

## LEAD SMELTER 2: Lead Smelter Sites

A list of several hundred sites in the U.S. where secondary lead smelting was done from 1931 and 1964. These sites may pose a threat to public health through ingestion or inhalation of contaminated soil or dust.

Date of Government Version: 04/05/2001	Source: American Journal of Public Health
Date Data Arrived at EDR: 10/27/2010	Telephone: 703-305-6451
Date Made Active in Reports: 12/02/2010	Last EDR Contact: 12/02/2009
Number of Days to Update: 36	Next Scheduled EDR Contact: N/A
	Data Release Frequency: No Update Planned

## US AIRS (AFS): Aerometric Information Retrieval System Facility Subsystem (AFS)

The database is a sub-system of Aerometric Information Retrieval System (AIRS). AFS contains compliance data on air pollution point sources regulated by the U.S. EPA and/or state and local air regulatory agencies. This information comes from source reports by various stationary sources of air pollution, such as electric power plants, steel mills, factories, and universities, and provides information about the air pollutants they produce. Action, air program, air program pollutant, and general level plant data. It is used to track emissions and compliance data from industrial plants.

Date of Government Version: 07/22/2015	Source: EPA
Date Data Arrived at EDR: 07/24/2015	Telephone: 202-564-2496
Date Made Active in Reports: 09/02/2015	Last EDR Contact: 06/22/2015
Number of Days to Update: 40	Next Scheduled EDR Contact: 10/05/2015
	Data Release Frequency: Annually

## US AIRS MINOR: Air Facility System Data

A listing of minor source facilities.

Date of Government Version: 07/22/2015	Source: EPA
Date Data Arrived at EDR: 07/24/2015	Telephone: 202-564-2496
Date Made Active in Reports: 09/02/2015	Last EDR Contact: 06/22/2015
Number of Days to Update: 40	Next Scheduled EDR Contact: 10/22/2015
	Data Release Frequency: Annually

# GOVERNMENT RECORDS SEARCHED / DATA CURRENCY TRACKING

## US MINES: Mines Master Index File

Contains all mine identification numbers issued for mines active or opened since 1971. The data also includes violation information.

Date of Government Version: 05/14/2015	Source: Department of Labor, Mine Safety and Health Administration
Date Data Arrived at EDR: 06/03/2015	Telephone: 303-231-5959
Date Made Active in Reports: 09/02/2015	Last EDR Contact: 09/01/2015
Number of Days to Update: 91	Next Scheduled EDR Contact: 12/14/2015
	Data Release Frequency: Semi-Annually

## US MINES 2: Ferrous and Nonferrous Metal Mines Database Listing

This map layer includes ferrous (ferrous metal mines are facilities that extract ferrous metals, such as iron ore or molybdenum) and nonferrous (Nonferrous metal mines are facilities that extract nonferrous metals, such as gold, silver, copper, zinc, and lead) metal mines in the United States.

Date of Government Version: 12/05/2005	Source: USGS
Date Data Arrived at EDR: 02/29/2008	Telephone: 703-648-7709
Date Made Active in Reports: 04/18/2008	Last EDR Contact: 06/05/2015
Number of Days to Update: 49	Next Scheduled EDR Contact: 09/14/2015
	Data Release Frequency: Varies

## US MINES 3: Active Mines & Mineral Plants Database Listing

Active Mines and Mineral Processing Plant operations for commodities monitored by the Minerals Information Team of the USGS.

Date of Government Version: 04/14/2011	Source: USGS
Date Data Arrived at EDR: 06/08/2011	Telephone: 703-648-7709
Date Made Active in Reports: 09/13/2011	Last EDR Contact: 06/05/2015
Number of Days to Update: 97	Next Scheduled EDR Contact: 09/14/2015
	Data Release Frequency: Varies

## FINDS: Facility Index System/Facility Registry System

Facility Index System. FINDS contains both facility information and 'pointers' to other sources that contain more detail. EDR includes the following FINDS databases in this report: PCS (Permit Compliance System), AIRS (Aerometric Information Retrieval System), DOCKET (Enforcement Docket used to manage and track information on civil judicial enforcement cases for all environmental statutes), FURS (Federal Underground Injection Control), C-DOCKET (Criminal Docket System used to track criminal enforcement actions for all environmental statutes), FFIS (Federal Facilities Information System), STATE (State Environmental Laws and Statutes), and PADS (PCB Activity Data System).

Date of Government Version: 01/18/2015	Source: EPA
Date Data Arrived at EDR: 02/27/2015	Telephone: (404) 562-9900
Date Made Active in Reports: 03/25/2015	Last EDR Contact: 06/10/2015
Number of Days to Update: 26	Next Scheduled EDR Contact: 09/21/2015
	Data Release Frequency: Quarterly

## AIRS: Air Quality Information Listing

Air emissions information.

Date of Government Version: 12/31/2013	Source: Department of Environmental Quality
Date Data Arrived at EDR: 03/19/2015	Telephone: 601-961-5276
Date Made Active in Reports: 03/26/2015	Last EDR Contact: 05/22/2015
Number of Days to Update: 7	Next Scheduled EDR Contact: 09/07/2015
	Data Release Frequency: Annually

## ASBESTOS: Asbestos Project Listing

A listing of Air Division Asbestos Branch projects.

Date of Government Version: 06/27/2015	Source: Department of Environmental Quality
Date Data Arrived at EDR: 07/08/2015	Telephone: 601-961-5611
Date Made Active in Reports: 07/20/2015	Last EDR Contact: 06/23/2015
Number of Days to Update: 12	Next Scheduled EDR Contact: 10/12/2015
	Data Release Frequency: Varies

# GOVERNMENT RECORDS SEARCHED / DATA CURRENCY TRACKING

## DRYCLEANERS: Drycleaner Facilities Listing

A listing of drycleaner facilities.

Date of Government Version: 03/13/2015  
Date Data Arrived at EDR: 05/22/2015  
Date Made Active in Reports: 06/05/2015  
Number of Days to Update: 14

Source: Department of Environmental Quality  
Telephone: 601-961-5670  
Last EDR Contact: 05/18/2015  
Next Scheduled EDR Contact: 08/31/2015  
Data Release Frequency: Varies

## NPDES: Industrial & Municipal NPDES Facilities

Water discharge permit data.

Date of Government Version: 03/20/2015  
Date Data Arrived at EDR: 03/24/2015  
Date Made Active in Reports: 04/08/2015  
Number of Days to Update: 15

Source: Department of Environmental Quality  
Telephone: 601-961-5666  
Last EDR Contact: 08/12/2015  
Next Scheduled EDR Contact: 11/30/2015  
Data Release Frequency: Quarterly

## PERMITS: Environmental Site Information System Listing

The purpose of this system is to support the permitting and compliance activities of the Office of Pollution Control. Regulatory programs that are supported by this database are the Surface Water National Pollutant Discharge Elimination System (NPDES) Program; the Air Title V, Construction and Operating Programs; and the Solid and Hazardous Waste Programs.

Date of Government Version: 03/20/2015  
Date Data Arrived at EDR: 03/24/2015  
Date Made Active in Reports: 04/08/2015  
Number of Days to Update: 15

Source: The Office of Pollution Control  
Telephone: 601-961-5670  
Last EDR Contact: 08/12/2015  
Next Scheduled EDR Contact: 11/30/2015  
Data Release Frequency: Quarterly

## UIC: UIC Information

A listing of underground injection control wells.

Date of Government Version: 06/15/2015  
Date Data Arrived at EDR: 06/17/2015  
Date Made Active in Reports: 07/20/2015  
Number of Days to Update: 33

Source: State Oil & Gas Board  
Telephone: 601-576-4923  
Last EDR Contact: 06/17/2015  
Next Scheduled EDR Contact: 09/28/2015  
Data Release Frequency: Quarterly

## EDR HIGH RISK HISTORICAL RECORDS

### ***EDR Exclusive Records***

#### EDR MGP: EDR Proprietary Manufactured Gas Plants

The EDR Proprietary Manufactured Gas Plant Database includes records of coal gas plants (manufactured gas plants) compiled by EDR's researchers. Manufactured gas sites were used in the United States from the 1800's to 1950's to produce a gas that could be distributed and used as fuel. These plants used whale oil, rosin, coal, or a mixture of coal, oil, and water that also produced a significant amount of waste. Many of the byproducts of the gas production, such as coal tar (oily waste containing volatile and non-volatile chemicals), sludges, oils and other compounds are potentially hazardous to human health and the environment. The byproduct from this process was frequently disposed of directly at the plant site and can remain or spread slowly, serving as a continuous source of soil and groundwater contamination.

Date of Government Version: N/A  
Date Data Arrived at EDR: N/A  
Date Made Active in Reports: N/A  
Number of Days to Update: N/A

Source: EDR, Inc.  
Telephone: N/A  
Last EDR Contact: N/A  
Next Scheduled EDR Contact: N/A  
Data Release Frequency: No Update Planned

#### EDR US Hist Auto Stat: EDR Exclusive Historic Gas Stations

EDR has searched selected national collections of business directories and has collected listings of potential gas station/filling station/service station sites that were available to EDR researchers. EDR's review was limited to those categories of sources that might, in EDR's opinion, include gas station/filling station/service station establishments. The categories reviewed included, but were not limited to gas, gas station, gasoline station, filling station, auto, automobile repair, auto service station, service station, etc. This database falls within a category of information EDR classifies as "High Risk Historical Records", or HRHR. EDR's HRHR effort presents unique and sometimes proprietary data about past sites and operations that typically create environmental concerns, but may not show up in current government records searches.



# GOVERNMENT RECORDS SEARCHED / DATA CURRENCY TRACKING

Date of Government Version: N/A  
Date Data Arrived at EDR: N/A  
Date Made Active in Reports: N/A  
Number of Days to Update: N/A

Source: EDR, Inc.  
Telephone: N/A  
Last EDR Contact: N/A  
Next Scheduled EDR Contact: N/A  
Data Release Frequency: Varies

## EDR US Hist Cleaners: EDR Exclusive Historic Dry Cleaners

EDR has searched selected national collections of business directories and has collected listings of potential dry cleaner sites that were available to EDR researchers. EDR's review was limited to those categories of sources that might, in EDR's opinion, include dry cleaning establishments. The categories reviewed included, but were not limited to dry cleaners, cleaners, laundry, laundromat, cleaning/laundry, wash & dry etc. This database falls within a category of information EDR classifies as "High Risk Historical Records", or HRHR. EDR's HRHR effort presents unique and sometimes proprietary data about past sites and operations that typically create environmental concerns, but may not show up in current government records searches.

Date of Government Version: N/A  
Date Data Arrived at EDR: N/A  
Date Made Active in Reports: N/A  
Number of Days to Update: N/A

Source: EDR, Inc.  
Telephone: N/A  
Last EDR Contact: N/A  
Next Scheduled EDR Contact: N/A  
Data Release Frequency: Varies

## EDR RECOVERED GOVERNMENT ARCHIVES

### *Exclusive Recovered Govt. Archives*

#### RGA HWS: Recovered Government Archive State Hazardous Waste Facilities List

The EDR Recovered Government Archive State Hazardous Waste database provides a list of SHWS incidents derived from historical databases and includes many records that no longer appear in current government lists. Compiled from Records formerly available from the Department of Environmental Quality in Mississippi.

Date of Government Version: N/A  
Date Data Arrived at EDR: 07/01/2013  
Date Made Active in Reports: 01/08/2014  
Number of Days to Update: 191

Source: Department of Environmental Quality  
Telephone: N/A  
Last EDR Contact: 06/01/2012  
Next Scheduled EDR Contact: N/A  
Data Release Frequency: Varies

#### RGA LF: Recovered Government Archive Solid Waste Facilities List

The EDR Recovered Government Archive Landfill database provides a list of landfills derived from historical databases and includes many records that no longer appear in current government lists. Compiled from Records formerly available from the Department of Environmental Quality in Mississippi.

Date of Government Version: N/A  
Date Data Arrived at EDR: 07/01/2013  
Date Made Active in Reports: 01/20/2014  
Number of Days to Update: 203

Source: Department of Environmental Quality  
Telephone: N/A  
Last EDR Contact: 06/01/2012  
Next Scheduled EDR Contact: N/A  
Data Release Frequency: Varies

#### RGA LUST: Recovered Government Archive Leaking Underground Storage Tank

The EDR Recovered Government Archive Leaking Underground Storage Tank database provides a list of LUST incidents derived from historical databases and includes many records that no longer appear in current government lists. Compiled from Records formerly available from the Department of Environmental Quality in Mississippi.

Date of Government Version: N/A  
Date Data Arrived at EDR: 07/01/2013  
Date Made Active in Reports: 01/03/2014  
Number of Days to Update: 186

Source: Department of Environmental Quality  
Telephone: N/A  
Last EDR Contact: 06/01/2012  
Next Scheduled EDR Contact: N/A  
Data Release Frequency: Varies

# GOVERNMENT RECORDS SEARCHED / DATA CURRENCY TRACKING

## OTHER DATABASE(S)

Depending on the geographic area covered by this report, the data provided in these specialty databases may or may not be complete. For example, the existence of wetlands information data in a specific report does not mean that all wetlands in the area covered by the report are included. Moreover, the absence of any reported wetlands information does not necessarily mean that wetlands do not exist in the area covered by the report.

### NY MANIFEST: Facility and Manifest Data

Manifest is a document that lists and tracks hazardous waste from the generator through transporters to a TSD facility.

Date of Government Version: 08/01/2015	Source: Department of Environmental Conservation
Date Data Arrived at EDR: 08/06/2015	Telephone: 518-402-8651
Date Made Active in Reports: 08/24/2015	Last EDR Contact: 08/06/2015
Number of Days to Update: 18	Next Scheduled EDR Contact: 11/16/2015
	Data Release Frequency: Annually

### PA MANIFEST: Manifest Information

Hazardous waste manifest information.

Date of Government Version: 12/31/2014	Source: Department of Environmental Protection
Date Data Arrived at EDR: 07/24/2015	Telephone: 717-783-8990
Date Made Active in Reports: 08/18/2015	Last EDR Contact: 07/20/2015
Number of Days to Update: 25	Next Scheduled EDR Contact: 11/02/2015
	Data Release Frequency: Annually

### Oil/Gas Pipelines

Source: PennWell Corporation

Telephone: 281-546-1505

Petroleum Bundle (Crude Oil, Refined Products, Petrochemicals, Gas Liquids (LPG/NGL), and Specialty Gases (Miscellaneous)) N = Natural Gas Bundle (Natural Gas, Gas Liquids (LPG/NGL), and Specialty Gases (Miscellaneous)). This map includes information copyrighted by PennWell Corporation. This information is provided on a best effort basis and PennWell Corporation does not guarantee its accuracy nor warrant its fitness for any particular purpose. Such information has been reprinted with the permission of PennWell.

### Electric Power Transmission Line Data

Source: PennWell Corporation

Telephone: 800-823-6277

This map includes information copyrighted by PennWell Corporation. This information is provided on a best effort basis and PennWell Corporation does not guarantee its accuracy nor warrant its fitness for any particular purpose. Such information has been reprinted with the permission of PennWell.

**Sensitive Receptors:** There are individuals deemed sensitive receptors due to their fragile immune systems and special sensitivity to environmental discharges. These sensitive receptors typically include the elderly, the sick, and children. While the location of all sensitive receptors cannot be determined, EDR indicates those buildings and facilities - schools, daycares, hospitals, medical centers, and nursing homes - where individuals who are sensitive receptors are likely to be located.

### AHA Hospitals:

Source: American Hospital Association, Inc.

Telephone: 312-280-5991

The database includes a listing of hospitals based on the American Hospital Association's annual survey of hospitals.

### Medical Centers: Provider of Services Listing

Source: Centers for Medicare & Medicaid Services

Telephone: 410-786-3000

A listing of hospitals with Medicare provider number, produced by Centers of Medicare & Medicaid Services, a federal agency within the U.S. Department of Health and Human Services.

### Nursing Homes

Source: National Institutes of Health

Telephone: 301-594-6248

Information on Medicare and Medicaid certified nursing homes in the United States.

### Public Schools

Source: National Center for Education Statistics

Telephone: 202-502-7300

The National Center for Education Statistics' primary database on elementary and secondary public education in the United States. It is a comprehensive, annual, national statistical database of all public elementary and secondary schools and school districts, which contains data that are comparable across all states.

## GOVERNMENT RECORDS SEARCHED / DATA CURRENCY TRACKING

### Private Schools

Source: National Center for Education Statistics

Telephone: 202-502-7300

The National Center for Education Statistics' primary database on private school locations in the United States.

### Daycare Centers: Child Care Listing

Source: Department of Health

Telephone: 601-576-7613

**Flood Zone Data:** This data, available in select counties across the country, was obtained by EDR in 2003 & 2011 from the Federal Emergency Management Agency (FEMA). Data depicts 100-year and 500-year flood zones as defined by FEMA.

**NWI:** National Wetlands Inventory. This data, available in select counties across the country, was obtained by EDR in 2002, 2005 and 2010 from the U.S. Fish and Wildlife Service.

### Current USGS 7.5 Minute Topographic Map

Source: U.S. Geological Survey

### STREET AND ADDRESS INFORMATION

© 2010 Tele Atlas North America, Inc. All rights reserved. This material is proprietary and the subject of copyright protection and other intellectual property rights owned by or licensed to Tele Atlas North America, Inc. The use of this material is subject to the terms of a license agreement. You will be held liable for any unauthorized copying or disclosure of this material.

# GEOCHECK<sup>®</sup> - PHYSICAL SETTING SOURCE ADDENDUM

## TARGET PROPERTY ADDRESS

PORT OF GULFPORT  
WEST BEACH BOULEVARD  
GULFPORT, MS 39501

## TARGET PROPERTY COORDINATES

Latitude (North): 30.3643 - 30° 21' 51.48"  
Longitude (West): 89.0958 - 89° 5' 44.88"  
Universal Transverse Mercator: Zone 16  
UTM X (Meters): 298581.1  
UTM Y (Meters): 3360835.0  
Elevation: 10 ft. above sea level

## USGS TOPOGRAPHIC MAP

Target Property Map:	5637359 GULFPORT SOUTH, MS
Version Date:	2012
North Map:	5637355 GULFPORT NORTH, MS
Version Date:	2012
Southwest Map:	5637373 PASS CHRISTIAN, MS
Version Date:	2012
Northwest Map:	5637357 GULFPORT NW, MS
Version Date:	2012

EDR's GeoCheck Physical Setting Source Addendum is provided to assist the environmental professional in forming an opinion about the impact of potential contaminant migration.

Assessment of the impact of contaminant migration generally has two principal investigative components:

1. Groundwater flow direction, and
2. Groundwater flow velocity.

Groundwater flow direction may be impacted by surface topography, hydrology, hydrogeology, characteristics of the soil, and nearby wells. Groundwater flow velocity is generally impacted by the nature of the geologic strata.

# GEOCHECK<sup>®</sup> - PHYSICAL SETTING SOURCE SUMMARY

## GROUNDWATER FLOW DIRECTION INFORMATION

Groundwater flow direction for a particular site is best determined by a qualified environmental professional using site-specific well data. If such data is not reasonably ascertainable, it may be necessary to rely on other sources of information, such as surface topographic information, hydrologic information, hydrogeologic data collected on nearby properties, and regional groundwater flow information (from deep aquifers).

## TOPOGRAPHIC INFORMATION

Surface topography may be indicative of the direction of surficial groundwater flow. This information can be used to assist the environmental professional in forming an opinion about the impact of nearby contaminated properties or, should contamination exist on the target property, what downgradient sites might be impacted.

## TARGET PROPERTY TOPOGRAPHY

General Topographic Gradient: General SSE

## SURROUNDING TOPOGRAPHY: ELEVATION PROFILES

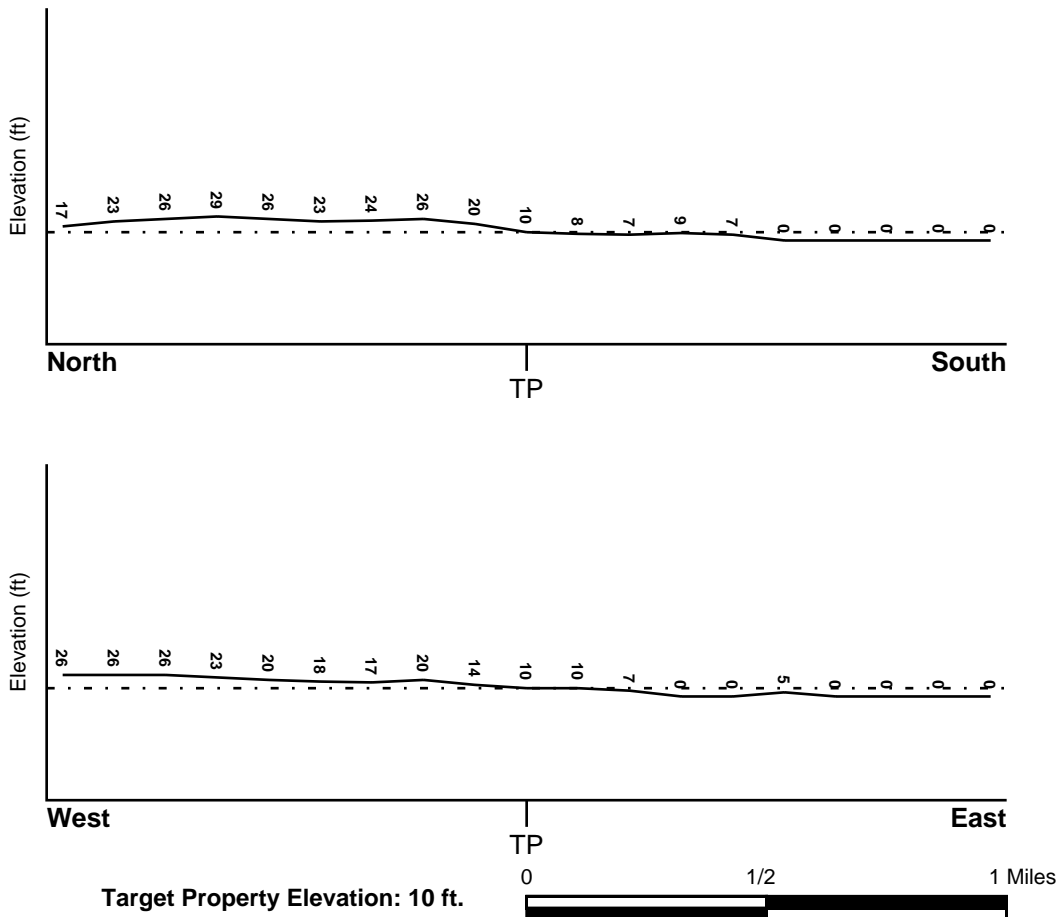

Source: Topography has been determined from the USGS 7.5' Digital Elevation Model and should be evaluated on a relative (not an absolute) basis. Relative elevation information between sites of close proximity should be field verified.

# GEOCHECK® - PHYSICAL SETTING SOURCE SUMMARY

## **HYDROLOGIC INFORMATION**

Surface water can act as a hydrologic barrier to groundwater flow. Such hydrologic information can be used to assist the environmental professional in forming an opinion about the impact of nearby contaminated properties or, should contamination exist on the target property, what downgradient sites might be impacted.

Refer to the Physical Setting Source Map following this summary for hydrologic information (major waterways and bodies of water).

## **FEMA FLOOD ZONE**

<u>Target Property County</u> HARRISON, MS	<u>FEMA Flood Electronic Data</u> YES - refer to the Overview Map and Detail Map
Flood Plain Panel at Target Property:	28047C - FEMA DFIRM Flood data
Additional Panels in search area:	Not Reported

## **NATIONAL WETLAND INVENTORY**

<u>NWI Quad at Target Property</u> GULFPORT SOUTH	<u>NWI Electronic Data Coverage</u> YES - refer to the Overview Map and Detail Map
--	---

## **HYDROGEOLOGIC INFORMATION**

Hydrogeologic information obtained by installation of wells on a specific site can often be an indicator of groundwater flow direction in the immediate area. Such hydrogeologic information can be used to assist the environmental professional in forming an opinion about the impact of nearby contaminated properties or, should contamination exist on the target property, what downgradient sites might be impacted.

## **AQUIFLOW®**

Search Radius: 1.000 Mile.

EDR has developed the AQUIFLOW Information System to provide data on the general direction of groundwater flow at specific points. EDR has reviewed reports submitted by environmental professionals to regulatory authorities at select sites and has extracted the date of the report, groundwater flow direction as determined hydrogeologically, and the depth to water table.

<u>MAP ID</u>	<u>LOCATION FROM TP</u>	<u>GENERAL DIRECTION GROUNDWATER FLOW</u>
Not Reported		

## **GEOCHECK® - PHYSICAL SETTING SOURCE SUMMARY**

### **GROUNDWATER FLOW VELOCITY INFORMATION**

Groundwater flow velocity information for a particular site is best determined by a qualified environmental professional using site specific geologic and soil strata data. If such data are not reasonably ascertainable, it may be necessary to rely on other sources of information, including geologic age identification, rock stratigraphic unit and soil characteristics data collected on nearby properties and regional soil information. In general, contaminant plumes move more quickly through sandy-gravelly types of soils than silty-clayey types of soils.

### **GEOLOGIC INFORMATION IN GENERAL AREA OF TARGET PROPERTY**

Geologic information can be used by the environmental professional in forming an opinion about the relative speed at which contaminant migration may be occurring.

#### **ROCK STRATIGRAPHIC UNIT**

Era:	Cenozoic
System:	Quaternary
Series:	Holocene
Code:	Qh <i>(decoded above as Era, System &amp; Series)</i>

#### **GEOLOGIC AGE IDENTIFICATION**

Category: Stratified Sequence

Geologic Age and Rock Stratigraphic Unit Source: P.G. Schruben, R.E. Arndt and W.J. Bawiec, Geology of the Conterminous U.S. at 1:2,500,000 Scale - a digital representation of the 1974 P.B. King and H.M. Beikman Map, USGS Digital Data Series DDS - 11 (1994).

# SSURGO SOIL MAP - 4407765.2s

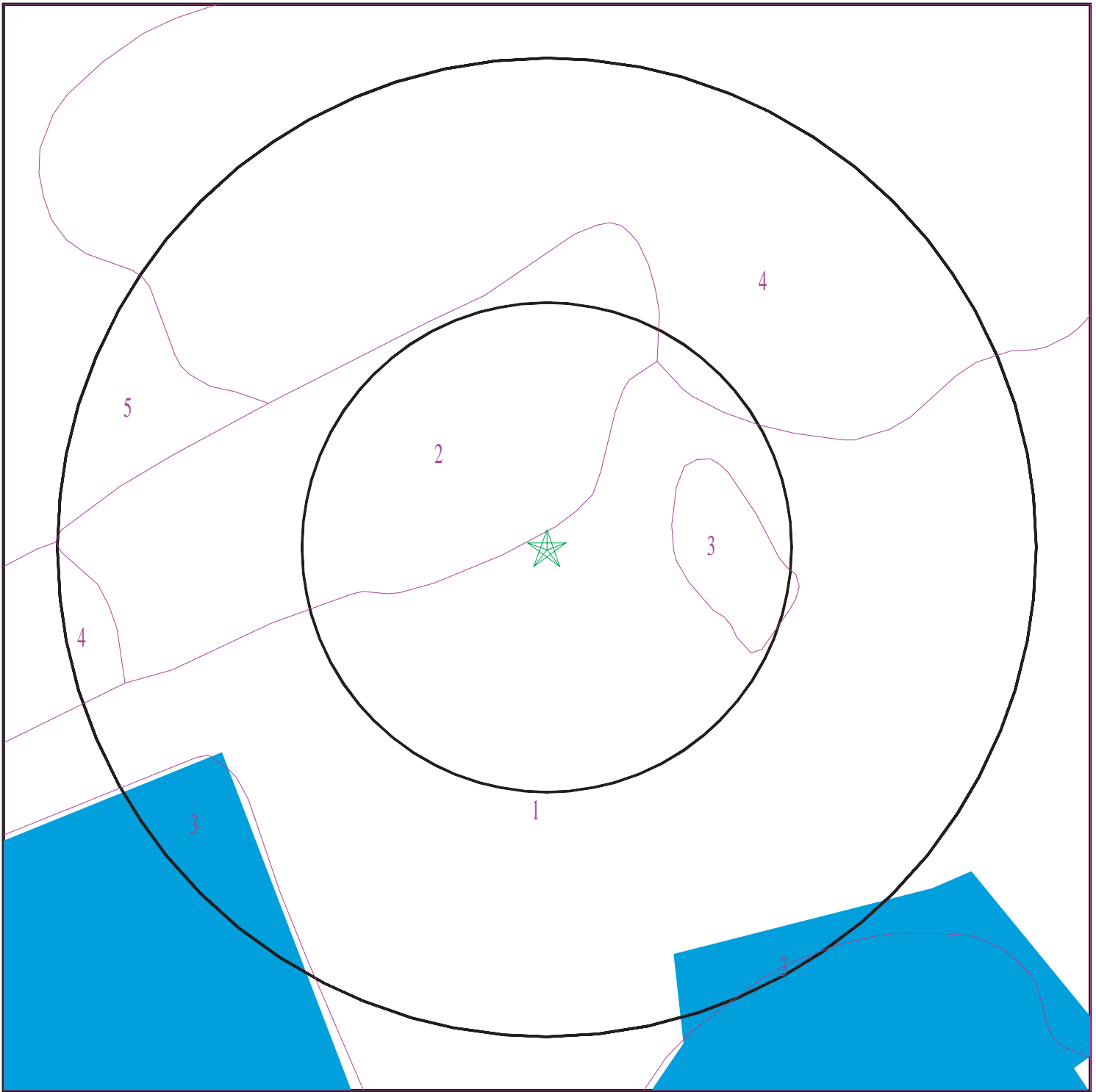

- ★ Target Property
- SSURGO Soil
- Water

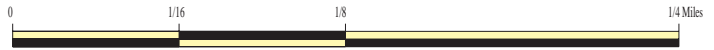

SITE NAME: Port of Gulfport  
ADDRESS: West Beach Boulevard  
Gulfport MS 39501  
LAT/LONG: 30.3643 / 89.0958

CLIENT: Atkins  
CONTACT: Brad Bayne  
INQUIRY #: 4407765.2s  
DATE: September 10, 2015 5:23 pm



# GEOCHECK® - PHYSICAL SETTING SOURCE SUMMARY

## DOMINANT SOIL COMPOSITION IN GENERAL AREA OF TARGET PROPERTY

The U.S. Department of Agriculture's (USDA) Soil Conservation Service (SCS) leads the National Cooperative Soil Survey (NCSS) and is responsible for collecting, storing, maintaining and distributing soil survey information for privately owned lands in the United States. A soil map in a soil survey is a representation of soil patterns in a landscape. The following information is based on Soil Conservation Service SSURGO data.

### Soil Map ID: 1

Soil Component Name: SULFAQUEPTS

Soil Surface Texture: sand

Hydrologic Group: Class D - Very slow infiltration rates. Soils are clayey, have a high water table, or are shallow to an impervious layer.

Soil Drainage Class: Poorly drained

Hydric Status: Not hydric

Corrosion Potential - Uncoated Steel: High

Depth to Bedrock Min: > 0 inches

Depth to Watertable Min: > 61 inches

Soil Layer Information							
Layer	Boundary		Soil Texture Class	Classification		Saturated hydraulic conductivity micro m/sec	Soil Reaction (pH)
	Upper	Lower		AASHTO Group	Unified Soil		
1	0 inches	12 inches	sand	Not reported	Not reported	Max: 141.14 Min: 42.34	Max: 6 Min: 3.6
2	12 inches	50 inches	sand	Not reported	Not reported	Max: 141.14 Min: 42.34	Max: 9 Min: 7.9

### Soil Map ID: 2

Soil Component Name: HARLESTON

Soil Surface Texture: fine sandy loam

Hydrologic Group: Class C - Slow infiltration rates. Soils with layers impeding downward movement of water, or soils with moderately fine or fine textures.

Soil Drainage Class: Moderately well drained

## GEOCHECK® - PHYSICAL SETTING SOURCE SUMMARY

Hydric Status: Partially hydric

Corrosion Potential - Uncoated Steel: Moderate

Depth to Bedrock Min: > 0 inches

Depth to Watertable Min: > 76 inches

Soil Layer Information							
Layer	Boundary		Soil Texture Class	Classification		Saturated hydraulic conductivity micro m/sec	Soil Reaction (pH)
	Upper	Lower		AASHTO Group	Unified Soil		
1	0 inches	9 inches	fine sandy loam	Not reported	Not reported	Max: 42.34 Min: 4.23	Max: 5.5 Min: 3.6
2	9 inches	59 inches		Not reported	Not reported	Max: 14.11 Min: 4.23	Max: 5.5 Min: 4.5
3	59 inches	72 inches		Not reported	Not reported	Max: 14.11 Min: 4.23	Max: 5.5 Min: 4.5

### Soil Map ID: 3

Soil Component Name: Water

Soil Surface Texture: fine sandy loam

Hydrologic Group: Class C - Slow infiltration rates. Soils with layers impeding downward movement of water, or soils with moderately fine or fine textures.

Soil Drainage Class:  
Hydric Status: Unknown

Corrosion Potential - Uncoated Steel: Not Reported

Depth to Bedrock Min: > 0 inches

Depth to Watertable Min: > 0 inches

No Layer Information available.

### Soil Map ID: 4

Soil Component Name: EUSTIS

Soil Surface Texture: loamy fine sand

Hydrologic Group: Class A - High infiltration rates. Soils are deep, well drained to excessively drained sands and gravels.

Soil Drainage Class: Somewhat excessively drained

## GEOCHECK® - PHYSICAL SETTING SOURCE SUMMARY

Hydric Status: Not hydric

Corrosion Potential - Uncoated Steel: Low

Depth to Bedrock Min: > 0 inches

Depth to Watertable Min: > 0 inches

Soil Layer Information							
Layer	Boundary		Soil Texture Class	Classification		Saturated hydraulic conductivity micro m/sec	Soil Reaction (pH)
	Upper	Lower		AASHTO Group	Unified Soil		
1	0 inches	5 inches	loamy fine sand	Not reported	Not reported	Max: 141.14 Min: 42.34	Max: 5.5 Min: 4.5
2	5 inches	24 inches		Not reported	Not reported	Max: 141.14 Min: 42.34	Max: 5.5 Min: 4.5
3	24 inches	75 inches		Not reported	Not reported	Max: 141.14 Min: 42.34	Max: 5.5 Min: 4.5
4	75 inches	98 inches		Not reported	Not reported	Max: 141.14 Min: 42.34	Max: 5.5 Min: 4.5

### Soil Map ID: 5

Soil Component Name: LATONIA

Soil Surface Texture: loamy sand

Hydrologic Group: Class B - Moderate infiltration rates. Deep and moderately deep, moderately well and well drained soils with moderately coarse textures.

Soil Drainage Class: Well drained

Hydric Status: Partially hydric

Corrosion Potential - Uncoated Steel: Low

Depth to Bedrock Min: > 0 inches

Depth to Watertable Min: > 0 inches

Soil Layer Information							
Layer	Boundary		Soil Texture Class	Classification		Saturated hydraulic conductivity micro m/sec	Soil Reaction (pH)
	Upper	Lower		AASHTO Group	Unified Soil		
1	0 inches	3 inches	loamy sand	Not reported	Not reported	Max: 141.14 Min: 42.34	Max: 5.5 Min: 4.5

## GEOCHECK® - PHYSICAL SETTING SOURCE SUMMARY

Soil Layer Information							
Layer	Boundary		Soil Texture Class	Classification		Saturated hydraulic conductivity micro m/sec	Soil Reaction (pH)
	Upper	Lower		AASHTO Group	Unified Soil		
2	3 inches	31 inches		Not reported	Not reported	Max: 42.34 Min: 14.11	Max: 5.5 Min: 4.5
3	31 inches	74 inches		Not reported	Not reported	Max: 141.14 Min: 42.34	Max: 5.5 Min: 4.5

### LOCAL / REGIONAL WATER AGENCY RECORDS

EDR Local/Regional Water Agency records provide water well information to assist the environmental professional in assessing sources that may impact ground water flow direction, and in forming an opinion about the impact of contaminant migration on nearby drinking water wells.

### WELL SEARCH DISTANCE INFORMATION

<u>DATABASE</u>	<u>SEARCH DISTANCE (miles)</u>
Federal USGS	1.000
Federal FRDS PWS	Nearest PWS within 0.500 miles
State Database	1.000

### FEDERAL USGS WELL INFORMATION

<u>MAP ID</u>	<u>WELL ID</u>	<u>LOCATION FROM TP</u>
A2	USGS40000608690	0 - 1/8 Mile SSW
A4	USGS40000608697	0 - 1/8 Mile WNW
B8	USGS40000608733	1/8 - 1/4 Mile North
C10	USGS40000608791	1/8 - 1/4 Mile NNW
D13	USGS40000608732	1/4 - 1/2 Mile NE
E15	USGS40000608790	1/4 - 1/2 Mile North
F19	USGS40000608899	1/4 - 1/2 Mile NNW
G21	USGS40000608593	1/4 - 1/2 Mile ESE
23	USGS40000608646	1/2 - 1 Mile ESE
H24	USGS40000608813	1/2 - 1 Mile NE
J26	USGS40000608851	1/2 - 1 Mile NNE
I28	USGS40000608704	1/2 - 1 Mile West
J30	USGS40000608850	1/2 - 1 Mile NNE
J32	USGS40000608883	1/2 - 1 Mile NNE
K35	USGS40000608882	1/2 - 1 Mile NNE
L38	USGS40000608818	1/2 - 1 Mile NE
M40	USGS40000608922	1/2 - 1 Mile North
N43	USGS40000608838	1/2 - 1 Mile NW
O46	USGS40000608507	1/2 - 1 Mile SE

# GEOCHECK® - PHYSICAL SETTING SOURCE SUMMARY

## FEDERAL USGS WELL INFORMATION

MAP ID	WELL ID	LOCATION FROM TP
N48	USGS40000608873	1/2 - 1 Mile NW
P51	USGS40000608717	1/2 - 1 Mile West
Q53	USGS40000608975	1/2 - 1 Mile North
R55	USGS40000608974	1/2 - 1 Mile NNE
Q57	USGS40000608998	1/2 - 1 Mile North
Q60	USGS40000609015	1/2 - 1 Mile North
S65	USGS40000608622	1/2 - 1 Mile West
U67	USGS40000608682	1/2 - 1 Mile West
T69	USGS40000608417	1/2 - 1 Mile SSE
W75	USGS40000608935	1/2 - 1 Mile NE
W76	USGS40000608936	1/2 - 1 Mile NE
X79	USGS40000609117	1/2 - 1 Mile NNE

## FEDERAL FRDS PUBLIC WATER SUPPLY SYSTEM INFORMATION

MAP ID	WELL ID	LOCATION FROM TP
D14	MS0240154	1/4 - 1/2 Mile NE

Note: PWS System location is not always the same as well location.

## STATE DATABASE WELL INFORMATION

MAP ID	WELL ID	LOCATION FROM TP
A1	MSC300000044307	0 - 1/8 Mile South
A3	MSC300000044308	0 - 1/8 Mile WNW
A5	MSC300000044941	0 - 1/8 Mile ENE
A6	MSC300000044994	0 - 1/8 Mile ENE
A7	MSC300000044942	0 - 1/8 Mile ENE
B9	MSC300000044306	1/8 - 1/4 Mile North
C11	MSC300000044574	1/4 - 1/2 Mile NNW
D12	MSC300000044303	1/4 - 1/2 Mile NE
E16	MSC300000044314	1/4 - 1/2 Mile North
F17	MSP300000000094	1/4 - 1/2 Mile NNW
F18	MSC300000044158	1/4 - 1/2 Mile NNW
G20	MSC300000044315	1/4 - 1/2 Mile ESE
22	MSH300000000074	1/4 - 1/2 Mile NNW
I25	MSC300000044838	1/2 - 1 Mile West
H27	MSC300000044805	1/2 - 1 Mile NE
J29	MSC300000044301	1/2 - 1 Mile NNE
J31	MSC300000044300	1/2 - 1 Mile NNE
J33	MSC300000044290	1/2 - 1 Mile NNE
34	MSU300000000042	1/2 - 1 Mile NNW
K36	MSC300000044302	1/2 - 1 Mile NNE
L37	MSPR300000000996	1/2 - 1 Mile NE
L39	MSC300000044425	1/2 - 1 Mile NE
M41	MSC300000044553	1/2 - 1 Mile North
N42	MSC300000044621	1/2 - 1 Mile NW
N44	MSPR30000001005	1/2 - 1 Mile NW

# GEOCHECK® - PHYSICAL SETTING SOURCE SUMMARY

## STATE DATABASE WELL INFORMATION

MAP ID	WELL ID	LOCATION FROM TP
O45	MSC300000044316	1/2 - 1 Mile SE
N47	MSPR30000001024	1/2 - 1 Mile NW
N49	MSC300000044745	1/2 - 1 Mile NW
P50	MSC300000044786	1/2 - 1 Mile West
P52	MSPR30000000937	1/2 - 1 Mile West
Q54	MSC300000044305	1/2 - 1 Mile North
R56	MSC300000044304	1/2 - 1 Mile NNE
Q58	MSPR30000001095	1/2 - 1 Mile North
Q59	MSC300000044159	1/2 - 1 Mile North
Q61	MSC300000044299	1/2 - 1 Mile North
S62	MSC300000044779	1/2 - 1 Mile West
T63	MSC300000044319	1/2 - 1 Mile SSE
S64	MSPR30000000878	1/2 - 1 Mile West
U66	MSC300000044575	1/2 - 1 Mile West
U68	MSPR30000000920	1/2 - 1 Mile West
T70	MSP300000000053	1/2 - 1 Mile SSE
71	MSC300000045016	1/2 - 1 Mile West
V72	MSC300000045046	1/2 - 1 Mile North
V73	MSC300000045071	1/2 - 1 Mile North
V74	MSC300000045075	1/2 - 1 Mile North
W77	MSC300000044296	1/2 - 1 Mile NE
W78	MSC300000044298	1/2 - 1 Mile NE
X80	MSC300000044541	1/2 - 1 Mile NNE

# PHYSICAL SETTING SOURCE MAP - 4407765.2s

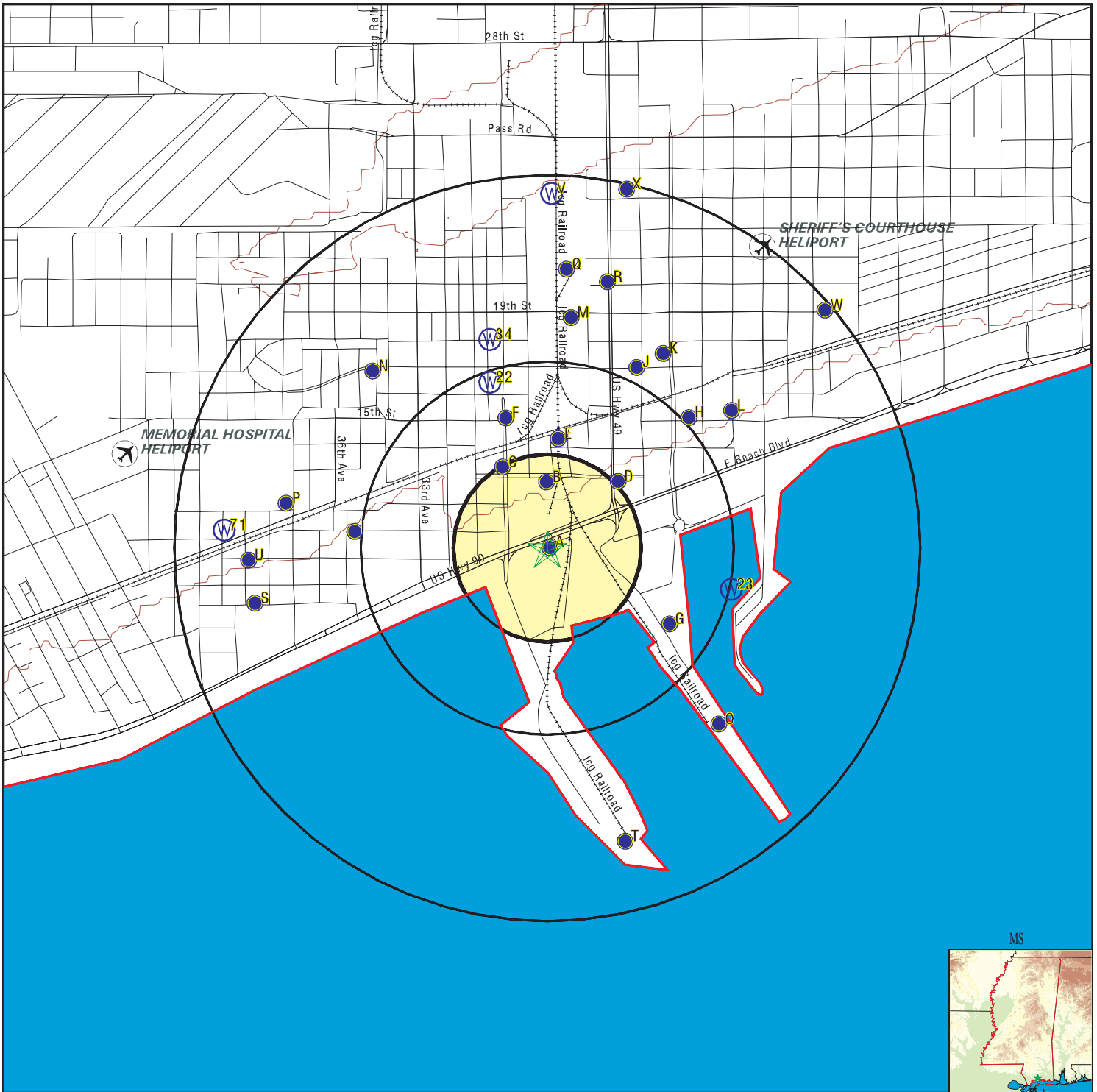

- County Boundary
- Major Roads
- Contour Lines
- Airports
- Earthquake epicenter, Richter 5 or greater
- Water Wells
- Public Water Supply Wells
- Cluster of Multiple Icons



- Groundwater Flow Direction
- Indeterminate Groundwater Flow at Location
- Groundwater Flow Varies at Location
- Oil, gas or related wells



SITE NAME: Port of Gulfport  
 ADDRESS: West Beach Boulevard  
 Gulfport MS 39501  
 LAT/LONG: 30.3643 / 89.0958

CLIENT: Atkins  
 CONTACT: Brad Bayne  
 INQUIRY #: 4407765.2s  
 DATE: September 10, 2015 5:23 pm

# GEOCHECK® - PHYSICAL SETTING SOURCE MAP FINDINGS

Map ID  
 Direction  
 Distance  
 Elevation

Database      EDR ID Number

**A1**  
**South**  
**0 - 1/8 Mile**  
**Higher**

**MS WELLS      MSC300000044307**

Fid:	44307	County nam:	HARRISON
Permit num:	Not Reported	Fip well:	047L0158
Doh number:	Not Reported	Aquifer:	Not Reported
Use:	UNUSED		
Owner name:	GREAT SOUTHERN HOTEL		
Section:	09	Township:	08S
Range:	11W		
Latdd:	30.3642		
Longdd:	-89.0958		
Casing dia:	4		
Casing len:	0		
Screen len:	0		
Well depth:	1260		
Site id:	MSC300000044307		

**A2**  
**SSW**  
**0 - 1/8 Mile**  
**Higher**

**FED USGS      USGS40000608690**

Org. Identifier:	USGS-MS		
Formal name:	USGS Mississippi Water Science Center		
Monloc Identifier:	USGS-302150089054501		
Monloc name:	L0158 HARRISON		
Monloc type:	Well		
Monloc desc:	Not Reported		
Huc code:	03170009	Drainagearea value:	Not Reported
Drainagearea Units:	Not Reported	Contrib drainagearea:	Not Reported
Contrib drainagearea units:	Not Reported	Latitude:	30.3640865
Longitude:	-89.095871	Sourcemap scale:	Not Reported
Horiz Acc measure:	10	Horiz Acc measure units:	seconds
Horiz Collection method:	Interpolated from map		
Horiz coord refsys:	NAD83	Vert measure val:	20.00
Vert measure units:	feet	Vertacc measure val:	.5
Vert accmeasure units:	feet		
Vertcollection method:	Level or other surveying method		
Vert coord refsys:	NGVD29	Countrycode:	US
Aquifername:	Not Reported		
Formation type:	Not Reported		
Aquifer type:	Not Reported		
Construction date:	19130101	Welldepth:	1260
Welldepth units:	ft	Wellholedepth:	Not Reported
Wellholedepth units:	Not Reported		

Ground-water levels, Number of Measurements: 1

Date	Feet below Surface	Feet to Sealevel
-----		
1939-03-01	-26.00	



## GEOCHECK® - PHYSICAL SETTING SOURCE MAP FINDINGS

Map ID  
 Direction  
 Distance  
 Elevation

Database      EDR ID Number

**A3**  
**WNW**  
**0 - 1/8 Mile**  
**Higher**

**MS WELLS      MSC300000044308**

Fid:	44308	County nam:	HARRISON
Permit num:	Not Reported	Fip well:	047L0159
Doh number:	Not Reported	Aquifer:	PASCAGOULA
Use:	UNUSED		
Owner name:	GREAT SOUTHERN HOTEL		
Section:	09	Township:	08S
Range:	11W		
Latdd:	30.3644		
Longdd:	-89.0961		
Casing dia:	4		
Casing len:	0		
Screen len:	0		
Well depth:	904		
Site id:	MSC300000044308		

**A4**  
**WNW**  
**0 - 1/8 Mile**  
**Higher**

**FED USGS      USGS40000608697**

Org. Identifier:	USGS-MS		
Formal name:	USGS Mississippi Water Science Center		
Monloc Identifier:	USGS-302151089054601		
Monloc name:	L0159 HARRISON		
Monloc type:	Well		
Monloc desc:	Not Reported		
Huc code:	03170009	Drainagearea value:	Not Reported
Drainagearea Units:	Not Reported	Contrib drainagearea:	Not Reported
Contrib drainagearea units:	Not Reported	Latitude:	30.3643643
Longitude:	-89.0961489	Sourcemap scale:	Not Reported
Horiz Acc measure:	10	Horiz Acc measure units:	seconds
Horiz Collection method:	Interpolated from map		
Horiz coord refsys:	NAD83	Vert measure val:	17.00
Vert measure units:	feet	Vertacc measure val:	.5
Vert accmeasure units:	feet		
Vertcollection method:	Level or other surveying method		
Vert coord refsys:	NGVD29	Countrycode:	US
Aquifername:	Coastal lowlands aquifer system		
Formation type:	Pascagoula Formation		
Aquifer type:	Not Reported		
Construction date:	19410101	Welldepth:	904
Welldepth units:	ft	Wellholedepth:	Not Reported
Wellholedepth units:	Not Reported		

Ground-water levels, Number of Measurements: 1

Date	Feet below Surface	Feet to Sealevel
-----		
1942-07-01	-21.00	

## GEOCHECK® - PHYSICAL SETTING SOURCE MAP FINDINGS

Map ID  
Direction  
Distance  
Elevation

Database      EDR ID Number

**A5**  
**ENE**  
**0 - 1/8 Mile**  
**Higher**

**MS WELLS      MSC300000044941**

Fid:	44941	County nam:	HARRISON
Permit num:	Not Reported	Fip well:	047L2069
Doh number:	Not Reported	Aquifer:	Not Reported
Use:	DOMESTIC		
Owner name:	SUPER B CONSTRUCTION		
Section:	09	Township:	08S
Range:	11W		
Latdd:	30.3644		
Longdd:	-89.0953		
Casing dia:	2		
Casing len:	430		
Screen len:	10		
Well depth:	440		
Site id:	MSC300000044941		

**A6**  
**ENE**  
**0 - 1/8 Mile**  
**Higher**

**MS WELLS      MSC300000044994**

Fid:	44994	County nam:	HARRISON
Permit num:	Not Reported	Fip well:	047L2125
Doh number:	Not Reported	Aquifer:	Not Reported
Use:	COMMERCIAL		
Owner name:	SOUTHERN FEDERAL		
Section:	09	Township:	08S
Range:	11W		
Latdd:	30.3644		
Longdd:	-89.0953		
Casing dia:	2		
Casing len:	0		
Screen len:	0		
Well depth:	300		
Site id:	MSC300000044994		

**A7**  
**ENE**  
**0 - 1/8 Mile**  
**Higher**

**MS WELLS      MSC300000044942**

Fid:	44942	County nam:	HARRISON
Permit num:	Not Reported	Fip well:	047L2070
Doh number:	Not Reported	Aquifer:	Not Reported
Use:	DOMESTIC		
Owner name:	SUPER B CONSTRUCTION		
Section:	09	Township:	08S
Range:	11W		
Latdd:	30.3644		
Longdd:	-89.0953		
Casing dia:	2		

# GEOCHECK® - PHYSICAL SETTING SOURCE MAP FINDINGS

Casing len: 430  
 Screen len: 10  
 Well depth: 440  
 Site id: MSC300000044942

**B8**  
**North**  
**1/8 - 1/4 Mile**  
**Higher**

**FED USGS      USGS40000608733**

Org. Identifier:	USGS-MS			
Formal name:	USGS Mississippi Water Science Center			
Monloc Identifier:	USGS-302200089054501			
Monloc name:	L0157 HARRISON			
Monloc type:	Well			
Monloc desc:	Not Reported			
Huc code:	03170009	Drainagearea value:	Not Reported	
Drainagearea Units:	Not Reported	Contrib drainagearea:	Not Reported	
Contrib drainagearea units:	Not Reported	Latitude:	30.3668643	
Longitude:	-89.0958711	Sourcemap scale:	Not Reported	
Horiz Acc measure:	10	Horiz Acc measure units:	seconds	
Horiz Collection method:	Interpolated from map			
Horiz coord refsys:	NAD83	Vert measure val:	24.00	
Vert measure units:	feet	Vertacc measure val:	.5	
Vert accmeasure units:	feet			
Vertcollection method:	Level or other surveying method			
Vert coord refsys:	NGVD29	Countrycode:	US	
Aquifername:	Coastal lowlands aquifer system			
Formation type:	Graham Ferry Formation			
Aquifer type:	Not Reported			
Construction date:	Not Reported	Welldepth:	865	
Welldepth units:	ft	Wellholedepth:	Not Reported	
Wellholedepth units:	Not Reported			

Ground-water levels, Number of Measurements: 1

Date	Feet below Surface	Feet to Sealevel
-----		
1939-01-01	-19.00	

**B9**  
**North**  
**1/8 - 1/4 Mile**  
**Higher**

**MS WELLS      MSC300000044306**

Fid:	44306	County nam:	HARRISON
Permit num:	Not Reported	Fip well:	047L0157
Doh number:	Not Reported	Aquifer:	GRAHAM FERRY
Use:	UNUSED		
Owner name:	MILNER, J W		
Section:	04	Township:	08S
Range:	11W		
Latdd:	30.3669		
Longdd:	-89.0958		
Casing dia:	0		

# GEOCHECK® - PHYSICAL SETTING SOURCE MAP FINDINGS

Casing len: 0  
 Screen len: 0  
 Well depth: 865  
 Site id: MSC300000044306

**C10**  
**NNW**  
**1/8 - 1/4 Mile**  
**Higher**

**FED USGS      USGS40000608791**

Org. Identifier:	USGS-MS			
Formal name:	USGS Mississippi Water Science Center			
Monloc Identifier:	USGS-302206089054302			
Monloc name:	L0450 HARRISON			
Monloc type:	Well			
Monloc desc:	Not Reported			
Huc code:	03170009	Drainagearea value:	Not Reported	
Drainagearea Units:	Not Reported	Contrib drainagearea:	Not Reported	
Contrib drainagearea units:	Not Reported	Latitude:	30.3674198	
Longitude:	-89.0978156	Sourcemap scale:	Not Reported	
Horiz Acc measure:	5	Horiz Acc measure units:	seconds	
Horiz Collection method:	Interpolated from map			
Horiz coord refsys:	NAD83	Vert measure val:	26.00	
Vert measure units:	feet	Vertacc measure val:	10	
Vert accmeasure units:	feet			
Vertcollection method:	Unknown			
Vert coord refsys:	NGVD29	Countrycode:	US	
Aquifername:	Coastal lowlands aquifer system			
Formation type:	Pascagoula Formation			
Aquifer type:	Not Reported			
Construction date:	19810929	Welldepth:	850	
Welldepth units:	ft	Wellholedepth:	850	
Wellholedepth units:	ft			

Ground-water levels, Number of Measurements: 1

Date	Feet below Surface	Feet to Sealevel
-----		
1981-09-29	35.00	

**C11**  
**NNW**  
**1/4 - 1/2 Mile**  
**Higher**

**MS WELLS      MSC300000044574**

Fid:	44574	County nam:	HARRISON
Permit num:	Not Reported	Fip well:	047L0450
Doh number:	Not Reported	Aquifer:	PASCAGOULA
Use:	INDUSTRIAL		
Owner name:	AMERICAN LINEN SUPPLY		
Section:	09	Township:	08S
Range:	11W		
Latdd:	30.3675		
Longdd:	-89.0978		
Casing dia:	6		

## GEOCHECK® - PHYSICAL SETTING SOURCE MAP FINDINGS

Casing len: 830  
 Screen len: 0  
 Well depth: 850  
 Site id: MSC300000044574

**D12**  
**NE**  
**1/4 - 1/2 Mile**  
**Higher**

**MS WELLS      MSC300000044303**

Fid:	44303	County nam:	HARRISON
Permit num:	Not Reported	Fip well:	047L0154
Doh number:	Not Reported	Aquifer:	PASCAGOULA
Use:	UNUSED		
Owner name:	US POSTAL SERVICE		
Section:	09	Township:	08S
Range:	11W		
Latdd:	30.3667		
Longdd:	-89.0925		
Casing dia:	3		
Casing len:	0		
Screen len:	0		
Well depth:	1262		
Site id:	MSC300000044303		

**D13**  
**NE**  
**1/4 - 1/2 Mile**  
**Higher**

**FED USGS      USGS40000608732**

Org. Identifier:	USGS-MS	Drainagearea value:	Not Reported
Formal name:	USGS Mississippi Water Science Center	Contrib drainagearea:	Not Reported
Monloc Identifier:	USGS-302200089053301	Latitude:	30.3668643
Monloc name:	L0154 HARRISON	Sourcemap scale:	Not Reported
Monloc type:	Well	Horiz Acc measure units:	seconds
Monloc desc:	Not Reported		
Huc code:	03170009	Vert measure val:	21.00
Drainagearea Units:	Not Reported	Vertacc measure val:	.1
Contrib drainagearea units:	Not Reported		
Longitude:	-89.0925376	Countrycode:	US
Horiz Acc measure:	1		
Horiz Collection method:	Interpolated from map		
Horiz coord refsys:	NAD83		
Vert measure units:	feet		
Vert accmeasure units:	feet		
Vertcollection method:	Level or other surveying method		
Vert coord refsys:	NGVD29		
Aquifername:	Coastal lowlands aquifer system		
Formation type:	Pascagoula Formation		
Aquifer type:	Not Reported		
Construction date:	19110101	Welldepth:	1262
Welldepth units:	ft	Wellholedepth:	Not Reported
Wellholedepth units:	Not Reported		

## GEOCHECK® - PHYSICAL SETTING SOURCE MAP FINDINGS

Ground-water levels, Number of Measurements: 297

Date	Feet below Surface	Feet to Sealevel	Date	Feet below Surface	Feet to Sealevel
1996-10-30	13.60		1996-07-11	13.45	
1996-04-24	13.08		1996-01-23	12.45	
1995-11-28	13.78		1995-04-10	12.95	
1994-10-18	13.72		1994-09-20	13.15	
1994-04-20	13.09		1994-04-13	13.70	
1994-01-20	13.31		1993-05-19	12.76	
1992-10-15	13.06		1992-04-16	13.81	
1991-10-22	12.58		1991-04-03	13.01	
1990-04-18	13.30		1990-03-21	13.90	
1989-10-03	14.29		1989-04-06	14.36	
1988-10-20	14.40		1988-04-07	14.03	
1987-10-15	14.65		1987-04-08	14.36	
1986-04-23	14.01		1985-11-20	13.52	
1984-09-13	13.08		1984-05-11	13.16	
1984-03-29	15.14		1983-10-26	13.68	
1983-04-20	13.31		1982-10-28	14.24	
1982-10-27	14.24		1982-04-28	13.22	
1981-10-21	13.85		1981-03-19	13.19	
1980-12-17	14.95		1980-04-18	12.49	
1980-04-15	12.49		1979-06-04	13.31	
1979-03-06	13.23		1978-10-04	14.59	
1978-04-11	13.33		1977-07-25	13.50	
1977-04-20	12.55		1976-10-28	12.96	
1976-09-02	12.59		1976-04-02	11.86	
1976-02-06	11.85		1975-10-01	11.20	
1975-06-11	10.82		1975-01-22	11.10	
1974-11-06	11.10		1974-07-16	11.44	
1974-04-03	9.78		1974-01-08	9.83	
1973-10-24	9.46		1973-07-26	9.25	
1973-04-24	7.93		1973-02-01	8.63	
1972-11-29	7.99		1972-10-20	7.54	
1972-07-11	7.34		1972-04-14	6.74	
1972-01-13	6.56		1971-10-22	7.05	
1971-08-12	6.62		1971-04-28	6.12	
1971-01-06	5.88		1970-10-21	5.45	
1970-07-22	5.97		1970-04-22	5.76	
1970-01-07	5.50		1969-10-08	4.89	
1969-08-20	4.20		1969-06-03	5.20	
1969-05-15	4.89		1969-01-22	3.80	
1968-11-22	3.96		1968-08-07	4.32	
1968-04-10	3.69		1968-01-09	2.44	
1967-10-03	3.12		1967-04-14	1.32	
1967-01-11	2.29		1966-10-07	2.19	
1966-07-29	1.90		1966-07-06	1.81	
1966-03-31	1.66		1966-01-04	1.62	
1965-09-30	1.36		1965-07-07	1.38	
1965-04-13	0.85		1965-01-20	1.01	
1964-10-21	-0.63		1964-07-14	-1.00	
1964-01-22	-2.30		1963-04-22	-3.00	
1963-01-16	-3.30		1962-11-07	-3.40	
1962-07-25	-3.80		1962-04-17	-3.60	
1962-01-31	-3.90		1961-10-26	-4.00	
1961-07-26	-5.20		1961-04-19	-5.20	
1961-01-25	-5.00		1960-11-01	-5.20	
1960-04-20	-6.00		1959-11-01	-5.20	

## GEOCHECK® - PHYSICAL SETTING SOURCE MAP FINDINGS

Ground-water levels, continued.

Date	Feet below Surface	Feet to Sealevel	Date	Feet below Surface	Feet to Sealevel
1959-07-14	-5.52		1959-03-03	-6.30	
1958-12-10	-6.40		1958-08-18	-6.70	
1958-06-04	-5.50		1958-05-14	-5.00	
1957-11-13	-6.90		1957-08-30	-7.90	
1957-06-17	-6.30		1957-03-21	-7.00	
1956-11-09	-6.90		1956-10-18	-6.50	
1956-10-15	-6.50		1956-06-19	-6.50	
1956-05-14	-7.20		1955-11-01	-7.10	
1955-08-24	-8.00		1955-06-02	-9.40	
1955-03-29	-8.50		1955-02-28	-7.70	
1955-01-18	-7.00		1954-12-22	-7.60	
1954-11-18	-7.60		1954-10-25	-7.60	
1954-09-06	-6.20		1954-08-16	-7.90	
1954-07-26	-8.00		1954-06-05	-8.10	
1954-05-05	-9.50		1954-04-25	-9.60	
1954-03-21	-9.40		1954-02-15	-9.90	
1954-01-25	-9.60		1950-10-12	-16.60	
1950-09-04	-16.50		1950-08-30	-16.00	
1950-07-19	-16.00		1950-06-11	-16.00	
1950-05-22	-16.30		1950-04-03	-18.00	
1950-03-08	-18.20		1950-02-14	-18.70	
1950-01-31	-18.50		1949-12-22	-18.40	
1949-11-12	-18.00		1949-10-05	-17.80	
1949-09-26	-17.80		1949-08-27	-17.30	
1948-12-01	-16.10		1948-11-27	-16.10	
1948-10-31	-15.00		1948-09-04	-13.40	
1948-08-23	-11.80		1948-07-04	-7.60	
1948-06-02	-12.20		1948-05-10	-17.30	
1948-04-04	-17.70		1948-03-23	-18.40	
1948-02-23	-18.30		1947-12-25	-18.00	
1947-11-30	-15.50		1947-10-31	-13.40	
1947-09-09	-12.00		1947-08-15	-11.90	
1947-07-01	-9.70		1947-06-05	-14.00	
1947-05-05	-15.70		1947-04-01	-17.90	
1947-03-07	-18.90		1947-02-01	-20.10	
1947-01-29	-18.70		1946-12-26	-17.50	
1946-11-22	-15.50		1946-10-07	-16.70	
1946-09-30	-16.50		1946-08-01	-16.30	
1946-07-08	-16.70		1946-06-02	-17.70	
1946-05-28	-17.50		1946-04-03	-20.30	
1946-03-30	-19.50		1946-02-21	-18.70	
1946-01-30	-19.70		1945-12-27	-18.70	
1945-11-12	-15.40		1945-10-15	-14.90	
1945-09-25	-10.90		1945-08-23	-10.70	
1945-07-01	-10.60		1945-06-05	-11.20	
1945-05-01	-14.20		1945-04-01	-14.50	
1945-03-04	-14.00		1945-02-06	-13.70	
1945-01-01	-14.40		1944-12-18	-13.90	
1944-11-04	-14.30		1944-10-02	-11.40	
1944-09-04	-12.50		1944-08-14	-14.00	
1944-07-17	-12.70		1944-06-04	-12.80	
1944-05-10	-20.20		1944-04-15	-20.20	
1944-03-22	-20.30		1944-02-28	-18.90	
1944-01-30	-18.90		1943-12-04	-19.10	
1943-11-15	-19.10		1943-10-06	-19.00	

## GEOCHECK® - PHYSICAL SETTING SOURCE MAP FINDINGS

Ground-water levels, continued.

Date	Feet below Surface	Feet to Sealevel	Date	Feet below Surface	Feet to Sealevel
1943-09-29	-18.70		1943-08-23	-17.90	
1943-07-05	-17.90		1943-06-28	-18.00	
1943-05-13	-19.70		1943-04-09	-21.20	
1943-03-11	-20.80		1943-02-10	-20.80	
1943-01-20	-20.60		1942-12-26	-20.10	
1942-11-06	-20.50		1942-10-08	-21.40	
1942-09-28	-21.10		1942-08-20	-21.70	
1942-07-07	-22.10		1942-06-04	-23.30	
1942-05-18	-23.40		1942-04-09	-23.70	
1942-03-17	-23.70		1942-02-16	-23.50	
1942-01-01	-23.50		1941-12-23	-22.20	
1941-11-15	-21.90		1941-10-02	-23.20	
1941-09-13	-23.00		1941-08-02	-22.90	
1941-07-05	-23.10		1941-06-23	-23.20	
1941-05-05	-25.50		1941-04-04	-24.00	
1941-03-20	-23.70		1941-02-13	-23.30	
1941-01-16	-23.90		1940-12-27	-24.00	
1940-12-22	-22.80		1940-12-17	-26.10	
1940-12-10	-21.70		1940-11-30	-25.80	
1940-11-25	-23.70		1940-11-15	-21.80	
1940-11-03	-20.60		1940-10-23	-20.70	
1940-10-13	-23.80		1940-10-09	-20.10	
1940-09-30	-23.70		1940-09-13	-18.60	
1940-09-07	-19.80		1940-08-15	-24.00	
1940-08-02	-20.70		1940-07-25	-23.10	
1940-07-18	-20.60		1940-06-11	-23.10	
1940-06-07	-21.00		1940-05-31	-20.90	
1940-05-01	-24.20		1940-04-23	-25.40	
1940-04-14	-21.70		1940-03-30	-24.50	
1940-03-09	-18.60		1940-02-10	-16.60	
1940-02-09	-24.00		1940-01-31	-27.10	
1940-01-29	-16.00		1939-12-22	-22.80	
1939-12-17	-26.10		1939-11-30	-25.80	
1939-11-03	-20.60		1939-10-21	-20.10	
1939-10-09	-24.70		1939-09-02	-23.70	
1939-08-11	-20.60		1939-08-01	-26.00	
1939-07-31	-26.30		1939-07-01	-22.80	
1939-06-25	-23.00		1939-06-15	-26.50	
1939-03-15	-21.70				

**D14  
NE  
1/4 - 1/2 Mile  
Higher**

**FRDS PWS MS0240154**

Epa region:	04	State:	MS
Pwsid:	MS0240154		
Pwsname:	HARRISON CENTRAL HIGH SCHOOL		
City served:	Not Reported	State served:	MS
Zip served:	Not Reported	Fips county:	28047
Status:	Active	Pop srvd:	1446
Pwsvconn:	1	Source:	Groundwater
Pws type:	NTNCWS	Owner:	Local_Govt
Contact:	BENEFIELD, LARRY		
Contacto rname:	BENEFIELD, LARRY		



## GEOCHECK® - PHYSICAL SETTING SOURCE MAP FINDINGS

Contact phone:	228-539-7215	Contact address1:	11072 HWY 49
Contact address2:	Not Reported	Contact city:	GULFPORT
Contact state:	MS	Contact zip:	39503
Activity code:	A		
Facid:	32142		
Facname:	TREATMENT FACILITY TF101		
Facility type:	Treatment_plant	Activity code:	A
Treatment obj:	corrosion control	Treatment process:	inhibitor, polyphosphate
Treatment obj:	disinfection	Treatment process:	gaseous chlorination, post

**Location Information:**

Name:	HARRISON CENTRAL HIGH SCHOOL		
Pwstypcd:	NTNCWS	Prmsrccd:	GW
Popserved:	1175		
Add1:	11072 HWY 49		
Add2:	Not Reported		
City:	GULFPORT	State:	MS
Zip:	39503	Phone:	228-832-1592
Cityserv:	Not Reported	Cntyserv:	Harrison
Stateserv:	MS	Zipserv:	Not Reported

PWS ID:	MS0240154		
Date Initiated:	7401	Date Deactivated:	Not Reported
PWS Name:	HARRISON CENTRAL HIGH SCHOOL KENNETH J. ABSHIRE P.O. BOX 1090 GULFPORT, MS 39502		

Addressee / Facility: Other  
HARRISON CENTRAL HIGH SCHOOL  
STEPHEN D WITTMANN  
P O BOX 6336  
BILOXI, MS 39532

Facility Latitude:	30 22 01	Facility Longitude:	089 05 34
City Served:	GULFPORT		
Treatment Class:	Untreated	Population:	00001400

Violations information not reported.

**ENFORCEMENT INFORMATION:**

Truedate:	03/31/2009	Pwsid:	MS0240154
Pwsname:	HARRISON CENTRAL HIGH SCHOOL		
Retpopsrvd:	1667	Pwstypcod:	NTNC
Void:	13504	Contaminant:	0999
Viol. Type:	Monitoring and Reporting Stage 1		
Complperbe:	4/1/2004 0:00:00		
Complperen:	6/30/2004 0:00:00	Enfdate:	No Enf Action as of
Enf action:	7/8/2009 0:00:00		
Violmeasur:	Not Reported		

System Name:	HARRISON CENTRAL HIGH SCHO		
Violation Type:	MCL, Monthly (TCR)		
Contaminant:	COLIFORM (TCR)		
Compliance Period:	1998-10-09 - 1998-11-09		
Violation ID:	98V00001		
Enforcement Date:	1998-10-09	Enf. Action:	State Public Notif Requested

# GEOCHECK® - PHYSICAL SETTING SOURCE MAP FINDINGS

**ENFORCEMENT INFORMATION:**

System Name: HARRISON CENTRAL HIGH SCHO  
 Violation Type: MCL, Monthly (TCR)  
 Contaminant: COLIFORM (TCR)  
 Compliance Period: 1998-10-09 - 1998-11-09  
 Violation ID: 98V00001  
 Enforcement Date: 1998-10-16      Enf. Action: State Public Notif Received

**CONTACT INFORMATION:**

Name: HARRISON CENTRAL HIGH SCHOOL      Population: 1667  
 Contact: DAVIS, COOPER      Phone: Not Reported  
 Address: 11072 HWY 49  
 Address 2: GULFPORT  
 MS, 39 228-8

**E15  
 North  
 1/4 - 1/2 Mile  
 Higher**

**FED USGS      USGS40000608790**

Org. Identifier: USGS-MS  
 Formal name: USGS Mississippi Water Science Center  
 Monloc Identifier: USGS-302206089054301  
 Monloc name: L0169 HARRISON  
 Monloc type: Well  
 Monloc desc: Not Reported  
 Huc code: 03170009      Drainagearea value: Not Reported  
 Drainagearea Units: Not Reported      Contrib drainagearea: Not Reported  
 Contrib drainagearea units: Not Reported      Latitude: 30.3685309  
 Longitude: -89.0953156      Sourcemap scale: Not Reported  
 Horiz Acc measure: 5      Horiz Acc measure units: seconds  
 Horiz Collection method: Interpolated from map  
 Horiz coord refsys: NAD83      Vert measure val: 11.00  
 Vert measure units: feet      Vertacc measure val: .5  
 Vert accmeasure units: feet  
 Vertcollection method: Level or other surveying method  
 Vert coord refsys: NGVD29      Countrycode: US  
 Aquifername: Coastal lowlands aquifer system  
 Formation type: Graham Ferry Formation  
 Aquifer type: Not Reported  
 Construction date: 19350101      Welldepth: 890  
 Welldepth units: ft      Wellholedepth: Not Reported  
 Wellholedepth units: Not Reported

Ground-water levels, Number of Measurements: 4

Date	Feet below Surface	Feet to Sealevel	Date	Feet below Surface	Feet to Sealevel
1982-10-27	15.92		1979-06-05	7.43	
1956-06-20	18.20		1939-03-14	38.70	

**E16  
 North  
 1/4 - 1/2 Mile  
 Higher**

**MS WELLS      MSC300000044314**

## GEOCHECK® - PHYSICAL SETTING SOURCE MAP FINDINGS

Fid:	44314	County nam:	HARRISON
Permit num:	Not Reported	Fip well:	047L0169
Doh number:	Not Reported	Aquifer:	GRAHAM FERRY
Use:	UNUSED		
Owner name:	GULFPORT PORT	Township:	08S
Section:	04		
Range:	11W		
Latdd:	30.3686		
Longdd:	-89.0953		
Casing dia:	6		
Casing len:	0		
Screen len:	0		
Well depth:	890		
Site id:	MSC300000044314		

**F17  
NNW  
1/4 - 1/2 Mile  
Higher**

**MS WELLS    MSP300000000094**

Cnty:	47	Aquifer:	PCGLU
Latn:	302209	Longn:	890551
Use 1:	MU	Source:	UPPER PASCAGOULA AQUIFER
Depth:	821		
Ownname:	GULFPORT, CITY OF		
Applname:	GULFPORT, CITY OF		
Site id:	MSP300000000094		

**F18  
NNW  
1/4 - 1/2 Mile  
Higher**

**MS WELLS    MSC300000044158**

Fid:	44158	County nam:	HARRISON
Permit num:	Not Reported	Fip well:	047L0002
Doh number:	0240003-03	Aquifer:	LOWER GRAHAM FERRY
Use:	PUBLIC SUPPLY		
Owner name:	GULFPORT, CITY OF	Township:	08S
Section:	04		
Range:	11W		
Latdd:	30.3694		
Longdd:	-89.0978		
Casing dia:	16		
Casing len:	750		
Screen len:	0		
Well depth:	821		
Site id:	MSC300000044158		

**F19  
NNW  
1/4 - 1/2 Mile  
Higher**

**FED USGS    USGS40000608899**

## GEOCHECK® - PHYSICAL SETTING SOURCE MAP FINDINGS

Org. Identifier:	USGS-MS		
Formal name:	USGS Mississippi Water Science Center		
Monloc Identifier:	USGS-302220089055401		
Monloc name:	L0002 HARRISON		
Monloc type:	Well		
Monloc desc:	Not Reported		
Huc code:	03170009	Drainagearea value:	Not Reported
Drainagearea Units:	Not Reported	Contrib drainagearea:	Not Reported
Contrib drainagearea units:	Not Reported	Latitude:	30.3695083
Longitude:	-89.097675	Sourcemap scale:	Not Reported
Horiz Acc measure:	.1	Horiz Acc measure units:	seconds
Horiz Collection method:	Differentially corrected Global Positioning System (DGPS)		
Horiz coord refsys:	NAD83	Vert measure val:	22.
Vert measure units:	feet	Vertacc measure val:	10
Vert accmeasure units:	feet		
Vertcollection method:	Interpolated from topographic map		
Vert coord refsys:	NGVD29	Countrycode:	US
Aquifername:	Coastal lowlands aquifer system		
Formation type:	Pascagoula Formation		
Aquifer type:	Not Reported		
Construction date:	19640101	Welldepth:	815
Welldepth units:	ft	Wellholedepth:	Not Reported
Wellholedepth units:	Not Reported		

Ground-water levels, Number of Measurements: 65

Date	Feet below Surface	Feet to Sealevel	Date	Feet below Surface	Feet to Sealevel
1986-12-30	36.88				
	Note: The site had been pumped recently.				
1986-11-26	49.17				
	Note: The site had been pumped recently.				
1986-10-30	50.87				
	Note: The site had been pumped recently.				
1986-09-30	48.42				
	Note: The site had been pumped recently.				
1986-06-27	37.38				
	Note: The site had been pumped recently.				
1986-05-29	49.16				
	Note: The site had been pumped recently.				
1986-04-28	45.61				
	Note: The site had been pumped recently.				
1986-03-27	45.08				
	Note: The site had been pumped recently.				
1986-02-27	46.55				
	Note: The site had been pumped recently.				
1986-01-29	47.04				
	Note: The site had been pumped recently.				
1985-12-30	52.89				
	Note: The site had been pumped recently.				
1985-11-26	46.71				
	Note: The site had been pumped recently.				
1985-10-30	45.07				
	Note: The site had been pumped recently.				
1985-09-25	46.73				
	Note: The site had been pumped recently.				
1985-08-28	41.11				
	Note: The site had been pumped recently.				
1985-07-30	47.80				
	Note: The site had been pumped recently.				

## GEOCHECK® - PHYSICAL SETTING SOURCE MAP FINDINGS

Ground-water levels, continued.

Date	Feet below Surface	Feet to Sealevel	Date	Feet below Surface	Feet to Sealevel
1985-06-26	40.22				
	Note: The site had been pumped recently.				
1985-05-31	54.72				
	Note: The site had been pumped recently.				
1985-04-29	32.03				
	Note: The site had been pumped recently.				
1985-02-27	51.12				
	Note: The site had been pumped recently.				
1985-01-28	44.43				
	Note: The site had been pumped recently.				
1984-12-19	47.78				
	Note: The site had been pumped recently.				
1984-11-29	35.28				
	Note: The site had been pumped recently.				
1984-10-30	36.82				
	Note: The site had been pumped recently.				
1984-09-27	36.48				
	Note: The site had been pumped recently.				
1984-08-30	37.29				
	Note: The site had been pumped recently.				
1984-07-31	37.82				
	Note: The site had been pumped recently.				
1984-06-29	35.63				
	Note: The site had been pumped recently.				
1984-05-30	49.86				
	Note: The site had been pumped recently.				
1984-04-27	49.31				
	Note: The site had been pumped recently.				
1984-03-28	84.55				
	Note: The site had been pumped recently.				
1984-02-27	51.36				
	Note: The site had been pumped recently.				
1984-01-30	50.75				
	Note: The site had been pumped recently.				
1983-12-29	47.91				
	Note: The site had been pumped recently.				
1983-11-30	48.52				
	Note: The site had been pumped recently.				
1983-03-31	46.05				
	Note: The site had been pumped recently.				
1983-02-24	44.64				
	Note: The site had been pumped recently.				
1983-01-28	44.36				
	Note: The site had been pumped recently.				
1982-11-29	48.46				
	Note: The site had been pumped recently.				
1982-11-09	50.97				
	Note: The site had been pumped recently.				
1982-09-29	51.63				
	Note: The site had been pumped recently.				
1982-08-30	51.00				
	Note: The site had been pumped recently.				
1982-07-26	47.42				
	Note: The site had been pumped recently.				
1982-06-29	50.88				
	Note: The site had been pumped recently.				

## GEOCHECK® - PHYSICAL SETTING SOURCE MAP FINDINGS

Ground-water levels, continued.

Date	Feet below Surface	Feet to Sealevel	Date	Feet below Surface	Feet to Sealevel
1982-05-27	50.02				
	Note: The site had been pumped recently.				
1982-04-30	48.52				
	Note: The site had been pumped recently.				
1982-03-31	48.18				
	Note: The site had been pumped recently.				
1982-02-25	47.51				
	Note: The site had been pumped recently.				
1982-01-27	46.76				
	Note: The site had been pumped recently.				
1981-12-28	49.21				
	Note: The site had been pumped recently.				
1981-10-29	49.00				
	Note: The site had been pumped recently.				
1981-09-24	48.50				
	Note: The site had been pumped recently.				
1981-07-30	48.40				
	Note: The site had been pumped recently.				
1981-06-24	56.10				
	Note: The site had been pumped recently.				
1981-05-26	44.75				
	Note: The site had been pumped recently.				
1981-04-24	41.47				
	Note: The site had been pumped recently.				
1981-03-26	35.60				
	Note: The site had been pumped recently.				
1980-12-29	25.35				
	Note: The site had been pumped recently.				
1980-12-28	47.06				
	Note: The site had been pumped recently.				
1980-08-19	42.72				
	Note: The site had been pumped recently.				
1979-06-05	47.95				
	Note: The site had been pumped recently.				
1969-11-03	15.49				
	Note: The site had been pumped recently.				
1969-05-28	22.33				
	Note: The site had been pumped recently.				
1968-09-12	18.42				
	Note: The site had been pumped recently.				
1964-10-01	8.00				

**G20  
ESE  
1/4 - 1/2 Mile  
Lower**

**MS WELLS      MSC30000044315**

Fid:	44315	County nam:	HARRISON
Permit num:	Not Reported	Fip well:	047L0171
Doh number:	Not Reported	Aquifer:	GRAHAM FERRY
Use:	OTHER		
Owner name:	GULFPORT PORT		
Section:	04	Township:	08S
Range:	11W		
Latdd:	30.3614		
Longdd:	-89.0903		
Casing dia:	0		

# GEOCHECK® - PHYSICAL SETTING SOURCE MAP FINDINGS

Casing len: 0  
 Screen len: 0  
 Well depth: 730  
 Site id: MSC300000044315

**G21**  
**ESE**  
**1/4 - 1/2 Mile**  
**Lower**

**FED USGS USGS40000608593**

Org. Identifier:	USGS-MS		
Formal name:	USGS Mississippi Water Science Center		
Monloc Identifier:	USGS-302140089052501		
Monloc name:	L0171 HARRISON		
Monloc type:	Well		
Monloc desc:	Not Reported		
Huc code:	03170009	Drainagearea value:	Not Reported
Drainagearea Units:	Not Reported	Contrib drainagearea:	Not Reported
Contrib drainagearea units:	Not Reported	Latitude:	30.3613089
Longitude:	-89.0903153	Sourcemap scale:	Not Reported
Horiz Acc measure:	10	Horiz Acc measure units:	seconds
Horiz Collection method:	Interpolated from map		
Horiz coord refsys:	NAD83	Vert measure val:	7.00
Vert measure units:	feet	Vertacc measure val:	.5
Vert accmeasure units:	feet		
Vertcollection method:	Level or other surveying method		
Vert coord refsys:	NGVD29	Countrycode:	US
Aquifername:	Coastal lowlands aquifer system		
Formation type:	Graham Ferry Formation		
Aquifer type:	Not Reported		
Construction date:	Not Reported	Welldepth:	730
Welldepth units:	ft	Wellholedepth:	Not Reported
Wellholedepth units:	Not Reported		

Ground-water levels, Number of Measurements: 1

Date	Feet below Surface	Feet to Sealevel
-----		
1939-03-01	-40.00	

**22**  
**NNW**  
**1/4 - 1/2 Mile**  
**Higher**

**MS WELLS MSH30000000074**

Wellid:	240003-03	Name:	CITY OF GULFPORT
Latn:	302214	Longn:	890554
Type 1:	C	Cnty:	HARRISON
Fips:	47	Region:	1
Coname:	Harrison	Site id:	MSH300000000074

**23**  
**ESE**  
**1/2 - 1 Mile**  
**Lower**

**FED USGS USGS40000608646**

## GEOCHECK® - PHYSICAL SETTING SOURCE MAP FINDINGS

Org. Identifier:	USGS-MS		
Formal name:	USGS Mississippi Water Science Center		
Monloc Identifier:	USGS-302145089051501		
Monloc name:	L0191 HARRISON		
Monloc type:	Well		
Monloc desc:	Not Reported		
Huc code:	03170009	Drainagearea value:	Not Reported
Drainagearea Units:	Not Reported	Contrib drainagearea:	Not Reported
Contrib drainagearea units:	Not Reported	Latitude:	30.3626978
Longitude:	-89.0875374	Sourcemap scale:	Not Reported
Horiz Acc measure:	1	Horiz Acc measure units:	minutes
Horiz Collection method:	Interpolated from map		
Horiz coord refsys:	NAD83	Vert measure val:	7.00
Vert measure units:	feet	Vertacc measure val:	5.
Vert accmeasure units:	feet		
Vertcollection method:	Interpolated from topographic map		
Vert coord refsys:	NGVD29	Countrycode:	US
Aquifername:	Coastal lowlands aquifer system		
Formation type:	Graham Ferry Formation		
Aquifer type:	Not Reported		
Construction date:	19690101	Welldepth:	675
Welldepth units:	ft	Wellholedepth:	Not Reported
Wellholedepth units:	Not Reported		

Ground-water levels, Number of Measurements: 1

Date	Feet below Surface	Feet to Sealevel
-----		
1969-01-01	-10.00	

**H24  
NE  
1/2 - 1 Mile  
Higher**

**FED USGS      USGS40000608813**

Org. Identifier:	USGS-MS		
Formal name:	USGS Mississippi Water Science Center		
Monloc Identifier:	USGS-302209089052201		
Monloc name:	L0694 HARRISON		
Monloc type:	Well		
Monloc desc:	Not Reported		
Huc code:	03170009	Drainagearea value:	Not Reported
Drainagearea Units:	Not Reported	Contrib drainagearea:	Not Reported
Contrib drainagearea units:	Not Reported	Latitude:	30.3693643
Longitude:	-89.089482	Sourcemap scale:	Not Reported
Horiz Acc measure:	5	Horiz Acc measure units:	seconds
Horiz Collection method:	Interpolated from map		
Horiz coord refsys:	NAD83	Vert measure val:	22.
Vert measure units:	feet	Vertacc measure val:	5
Vert accmeasure units:	feet		
Vertcollection method:	Interpolated from topographic map		
Vert coord refsys:	NGVD29	Countrycode:	US
Aquifername:	Not Reported		
Formation type:	Not Reported		



## GEOCHECK® - PHYSICAL SETTING SOURCE MAP FINDINGS

Aquifer type:	Not Reported	Welldepth:	Not Reported
Construction date:	19940303	Wellholeddepth:	850
Welldepth units:	Not Reported		
Wellholeddepth units:	ft		

Ground-water levels, Number of Measurements: 0

**I25**  
**West**  
**1/2 - 1 Mile**  
**Higher**

**MS WELLS    MSC300000044838**

Fid:	44838	County nam:	HARRISON
Permit num:	Not Reported	Fip well:	047L0728
Doh number:	0240003-14	Aquifer:	UPPER PASCAGOULA
Use:	PUBLIC SUPPLY		
Owner name:	ISLAND VIEW CASINO GULFSIDE CASINO PARTNERS		
Section:	08	Township:	08S
Range:	11W		
Latdd:	30.3647		
Longdd:	-89.1044		
Casing dia:	16		
Casing len:	1776		
Screen len:	60		
Well depth:	1840		
Site id:	MSC300000044838		

**J26**  
**NNE**  
**1/2 - 1 Mile**  
**Higher**

**FED USGS    USGS40000608851**

Org. Identifier:	USGS-MS		
Formal name:	USGS Mississippi Water Science Center		
Monloc Identifier:	USGS-302215089053101		
Monloc name:	L0152 HARRISON		
Monloc type:	Well		
Monloc desc:	Not Reported		
Huc code:	03170009	Drainagearea value:	Not Reported
Drainagearea Units:	Not Reported	Contrib drainagearea:	Not Reported
Contrib drainagearea units:	Not Reported	Latitude:	30.3710309
Longitude:	-89.0919821	Sourcemap scale:	Not Reported
Horiz Acc measure:	10	Horiz Acc measure units:	seconds
Horiz Collection method:	Interpolated from map		
Horiz coord refsys:	NAD83	Vert measure val:	27.00
Vert measure units:	feet	Vertacc measure val:	.5
Vert accmeasure units:	feet		
Vertcollection method:	Level or other surveying method		
Vert coord refsys:	NGVD29	Countrycode:	US
Aquifername:	Coastal lowlands aquifer system		
Formation type:	Graham Ferry Formation		
Aquifer type:	Not Reported		
Construction date:	19040101	Welldepth:	862
Welldepth units:	ft	Wellholeddepth:	Not Reported
Wellholeddepth units:	Not Reported		

# GEOCHECK® - PHYSICAL SETTING SOURCE MAP FINDINGS

Ground-water levels, Number of Measurements: 1

Date	Feet below Surface	Feet to Sealevel
1904-01-01	-60.00	

**H27**  
**NE**  
**1/2 - 1 Mile**  
**Higher**

**MS WELLS      MSC300000044805**

Fid:	44805	County nam:	HARRISON
Permit num:	Not Reported	Fip well:	047L0694
Doh number:	Not Reported	Aquifer:	Not Reported
Use:	Not Reported		
Owner name:	GULFPORT, CITY OF		
Section:	04	Township:	08S
Range:	11W		
Latdd:	30.3694		
Longdd:	-89.0894		
Casing dia:	0		
Casing len:	0		
Screen len:	0		
Well depth:	0		
Site id:	MSC300000044805		

**I28**  
**West**  
**1/2 - 1 Mile**  
**Higher**

**FED USGS      USGS40000608704**

Org. Identifier:	USGS-MS		
Formal name:	USGS Mississippi Water Science Center		
Monloc Identifier:	USGS-302154089061601		
Monloc name:	L0728 HARRISON		
Monloc type:	Well		
Monloc desc:	Not Reported		
Huc code:	03170009	Drainagearea value:	Not Reported
Drainagearea Units:	Not Reported	Contrib drainagearea:	Not Reported
Contrib drainagearea units:	Not Reported	Latitude:	30.3651975
Longitude:	-89.1044825	Sourcemap scale:	Not Reported
Horiz Acc measure:	5	Horiz Acc measure units:	seconds
Horiz Collection method:	Interpolated from map		
Horiz coord refsys:	NAD83	Vert measure val:	7.
Vert measure units:	feet	Vertacc measure val:	5
Vert accmeasure units:	feet		
Vertcollection method:	Interpolated from topographic map		
Vert coord refsys:	NGVD29	Countrycode:	US
Aquifername:	Coastal lowlands aquifer system		
Formation type:	Hattiesburg Formation		
Aquifer type:	Not Reported		
Construction date:	19990212	Welldepth:	1840
Welldepth units:	ft	Wellholedepth:	1879
Wellholedepth units:	ft		

Ground-water levels, Number of Measurements: 0

## GEOCHECK® - PHYSICAL SETTING SOURCE MAP FINDINGS

Map ID  
Direction  
Distance  
Elevation

Database      EDR ID Number

**J29**  
**NNE**  
**1/2 - 1 Mile**  
**Higher**

**MS WELLS      MSC300000044301**

Fid:	44301	County nam:	HARRISON
Permit num:	Not Reported	Fip well:	047L0152
Doh number:	Not Reported	Aquifer:	GRAHAM FERRY
Use:	UNUSED		
Owner name:	GULFPORT, CITY OF		
Section:	04	Township:	08S
Range:	11W		
Latdd:	30.3711		
Longdd:	-89.0919		
Casing dia:	8		
Casing len:	0		
Screen len:	0		
Well depth:	862		
Site id:	MSC300000044301		

**J30**  
**NNE**  
**1/2 - 1 Mile**  
**Higher**

**FED USGS      USGS40000608850**

Org. Identifier:	USGS-MS		
Formal name:	USGS Mississippi Water Science Center		
Monloc Identifier:	USGS-302215089053001		
Monloc name:	L0151 HARRISON		
Monloc type:	Well		
Monloc desc:	Not Reported		
Huc code:	03170009	Drainagearea value:	Not Reported
Drainagearea Units:	Not Reported	Contrib drainagearea:	Not Reported
Contrib drainagearea units:	Not Reported	Latitude:	30.3710309
Longitude:	-89.0917043	Sourcemap scale:	Not Reported
Horiz Acc measure:	10	Horiz Acc measure units:	seconds
Horiz Collection method:	Interpolated from map		
Horiz coord refsys:	NAD83	Vert measure val:	25.00
Vert measure units:	feet	Vertacc measure val:	.5
Vert accmeasure units:	feet		
Vertcollection method:	Level or other surveying method		
Vert coord refsys:	NGVD29	Countrycode:	US
Aquifername:	Coastal lowlands aquifer system		
Formation type:	Pascagoula Formation		
Aquifer type:	Not Reported		
Construction date:	19210101	Welldepth:	1244
Welldepth units:	ft	Wellholedepth:	Not Reported
Wellholedepth units:	Not Reported		

Ground-water levels, Number of Measurements: 0

**J31**  
**NNE**  
**1/2 - 1 Mile**  
**Higher**

**MS WELLS      MSC300000044300**

## GEOCHECK® - PHYSICAL SETTING SOURCE MAP FINDINGS

Fid:	44300	County nam:	HARRISON
Permit num:	Not Reported	Fip well:	047L0151
Doh number:	Not Reported	Aquifer:	PASCAGOULA
Use:	UNUSED		
Owner name:	GULFPORT, CITY OF		
Section:	04	Township:	08S
Range:	11W		
Latdd:	30.3711		
Longdd:	-89.0917		
Casing dia:	10		
Casing len:	0		
Screen len:	0		
Well depth:	1244		
Site id:	MSC300000044300		

**J32  
NNE  
1/2 - 1 Mile  
Higher**

**FED USGS      USGS40000608883**

Org. Identifier:	USGS-MS		
Formal name:	USGS Mississippi Water Science Center		
Monloc Identifier:	USGS-302218089053001		
Monloc name:	L0140 HARRISON		
Monloc type:	Well		
Monloc desc:	Not Reported		
Huc code:	03170009	Drainagearea value:	Not Reported
Drainagearea Units:	Not Reported	Contrib drainagearea:	Not Reported
Contrib drainagearea units:	Not Reported	Latitude:	30.3718642
Longitude:	-89.0917043	Sourcemap scale:	Not Reported
Horiz Acc measure:	10	Horiz Acc measure units:	seconds
Horiz Collection method:	Interpolated from map		
Horiz coord refsys:	NAD83	Vert measure val:	25.00
Vert measure units:	feet	Vertacc measure val:	.5
Vert accmeasure units:	feet		
Vertcollection method:	Level or other surveying method		
Vert coord refsys:	NGVD29	Countrycode:	US
Aquifername:	Coastal lowlands aquifer system		
Formation type:	Pascagoula Formation		
Aquifer type:	Not Reported		
Construction date:	19150101	Welldepth:	960
Welldepth units:	ft	Wellholedepth:	Not Reported
Wellholedepth units:	Not Reported		

Ground-water levels, Number of Measurements: 1

Date	Feet below Surface	Feet to Sealevel
-----		
1939-03-01	5.90	

**J33  
NNE  
1/2 - 1 Mile  
Higher**

**MS WELLS      MSC300000044290**

## GEOCHECK® - PHYSICAL SETTING SOURCE MAP FINDINGS

Fid:	44290	County nam:	HARRISON
Permit num:	Not Reported	Fip well:	047L0140
Doh number:	Not Reported	Aquifer:	PASCAGOULA
Use:	UNUSED		
Owner name:	GULFPORT, CITY OF	Township:	08S
Section:	04		
Range:	11W		
Latdd:	30.3719		
Longdd:	-89.0917		
Casing dia:	4		
Casing len:	0		
Screen len:	0		
Well depth:	960		
Site id:	MSC300000044290		

**34  
NNW  
1/2 - 1 Mile  
Higher**

**MS WELLS      MSU300000000042**

Latn:	302220	Longn:	890554
Fips:	47	Local no:	L002
Use 1:	P	Aquifer:	121GRMF
Depth:	815	Site id:	MSU300000000042

**K35  
NNE  
1/2 - 1 Mile  
Higher**

**FED USGS      USGS40000608882**

Org. Identifier:	USGS-MS		
Formal name:	USGS Mississippi Water Science Center		
Monloc Identifier:	USGS-302218089052601		
Monloc name:	L0153 HARRISON		
Monloc type:	Well		
Monloc desc:	Not Reported		
Huc code:	03170009	Drainagearea value:	Not Reported
Drainagearea Units:	Not Reported	Contrib drainagearea:	Not Reported
Contrib drainagearea units:	Not Reported	Latitude:	30.3718642
Longitude:	-89.0905932	Sourcemap scale:	Not Reported
Horiz Acc measure:	10	Horiz Acc measure units:	seconds
Horiz Collection method:	Interpolated from map		
Horiz coord refsys:	NAD83	Vert measure val:	29.00
Vert measure units:	feet	Vertacc measure val:	.5
Vert accmeasure units:	feet		
Vertcollection method:	Level or other surveying method		
Vert coord refsys:	NGVD29	Countrycode:	US
Aquifername:	Coastal lowlands aquifer system		
Formation type:	Graham Ferry Formation		
Aquifer type:	Not Reported		
Construction date:	19000101	Welldepth:	900
Welldepth units:	ft	Wellholedepth:	Not Reported
Wellholedepth units:	Not Reported		

# GEOCHECK® - PHYSICAL SETTING SOURCE MAP FINDINGS

Ground-water levels, Number of Measurements: 1

Date	Feet below Surface	Feet to Sealevel
1939-03-01	-7.00	

**K36**  
**NNE**  
**1/2 - 1 Mile**  
**Higher**

**MS WELLS      MSC300000044302**

Fid:	44302	County nam:	HARRISON
Permit num:	Not Reported	Fip well:	047L0153
Doh number:	Not Reported	Aquifer:	GRAHAM FERRY
Use:	UNUSED		
Owner name:	GULFPORT, CITY OF		
Section:	04	Township:	08S
Range:	11W		
Latdd:	30.3719		
Longdd:	-89.0906		
Casing dia:	10		
Casing len:	0		
Screen len:	0		
Well depth:	900		
Site id:	MSC300000044302		

**L37**  
**NE**  
**1/2 - 1 Mile**  
**Higher**

**MS WELLS      MSPR30000000996**

Latn:	302210	Longn:	890515
Local no:	L289	Use 1:	H
Aquifer:	121CRNL	Depth:	30
County:	HARRISON	Fips:	47
Site id:	MSPR30000000996		

**L38**  
**NE**  
**1/2 - 1 Mile**  
**Higher**

**FED USGS      USGS40000608818**

Org. Identifier:	USGS-MS		
Formal name:	USGS Mississippi Water Science Center		
Monloc Identifier:	USGS-302210089051501		
Monloc name:	L0289 HARRISON		
Monloc type:	Well		
Monloc desc:	Not Reported		
Huc code:	03170009	Drainagearea value:	Not Reported
Drainagearea Units:	Not Reported	Contrib drainagearea:	Not Reported
Contrib drainagearea units:	Not Reported	Latitude:	30.3696421
Longitude:	-89.0875375	Sourcemap scale:	Not Reported

## GEOCHECK® - PHYSICAL SETTING SOURCE MAP FINDINGS

Horiz Acc measure:	10	Horiz Acc measure units:	seconds
Horiz Collection method:	Interpolated from map		
Horiz coord refsys:	NAD83	Vert measure val:	25.00
Vert measure units:	feet	Vertacc measure val:	5.
Vert accmeasure units:	feet		
Vertcollection method:	Interpolated from topographic map		
Vert coord refsys:	NGVD29	Countrycode:	US
Aquifername:	Coastal lowlands aquifer system		
Formation type:	Citronelle Formation		
Aquifer type:	Not Reported		
Construction date:	19690101	Welldepth:	30
Welldepth units:	ft	Wellholedepth:	Not Reported
Wellholedepth units:	Not Reported		

Ground-water levels, Number of Measurements: 1

Date	Feet below Surface	Feet to Sealevel
-----		
1969-04-01	4.00	

**L39**  
**NE**  
**1/2 - 1 Mile**  
**Higher**

**MS WELLS    MSC300000044425**

Fid:	44425	County nam:	HARRISON
Permit num:	Not Reported	Fip well:	047L0289
Doh number:	Not Reported	Aquifer:	CITRONELLE
Use:	DOMESTIC		
Owner name:	FAYARD, MARGARET		
Section:	09	Township:	07S
Range:	11W		
Latdd:	30.3697		
Longdd:	-89.0875		
Casing dia:	1		
Casing len:	0		
Screen len:	0		
Well depth:	30		
Site id:	MSC300000044425		

**M40**  
**North**  
**1/2 - 1 Mile**  
**Higher**

**FED USGS    USGS40000608922**

Org. Identifier:	USGS-MS		
Formal name:	USGS Mississippi Water Science Center		
Monloc Identifier:	USGS-302223089054101		
Monloc name:	L0425 HARRISON		
Monloc type:	Well		
Monloc desc:	Not Reported		
Huc code:	03170009	Drainagearea value:	Not Reported
Drainagearea Units:	Not Reported	Contrib drainagearea:	Not Reported
Contrib drainagearea units:	Not Reported	Latitude:	30.3732531
Longitude:	-89.09476	Sourcemap scale:	Not Reported

## GEOCHECK® - PHYSICAL SETTING SOURCE MAP FINDINGS

Horiz Acc measure:	5	Horiz Acc measure units:	seconds
Horiz Collection method:	Interpolated from map		
Horiz coord refsys:	NAD83	Vert measure val:	25.
Vert measure units:	feet	Vertacc measure val:	10
Vert accmeasure units:	feet		
Vertcollection method:	Unknown		
Vert coord refsys:	NGVD29	Countrycode:	US
Aquifername:	Not Reported		
Formation type:	Not Reported		
Aquifer type:	Not Reported		
Construction date:	19770628	Welldepth:	Not Reported
Welldepth units:	Not Reported	Wellholedepth:	996
Wellholedepth units:	ft		

Ground-water levels, Number of Measurements: 0

**M41  
North  
1/2 - 1 Mile  
Higher**

**MS WELLS    MSC300000044553**

Fid:	44553	County nam:	HARRISON
Permit num:	Not Reported	Fip well:	047L0425
Doh number:	Not Reported	Aquifer:	Not Reported
Use:	UNUSED		
Owner name:	GULFPORT, CITY OF		
Section:	04	Township:	08S
Range:	11W		
Latdd:	30.3733		
Longdd:	-89.0947		
Casing dia:	0		
Casing len:	0		
Screen len:	0		
Well depth:	0		
Site id:	MSC300000044553		

**N42  
NW  
1/2 - 1 Mile  
Higher**

**MS WELLS    MSC300000044621**

Fid:	44621	County nam:	HARRISON
Permit num:	Not Reported	Fip well:	047L0497
Doh number:	Not Reported	Aquifer:	CITRONELLE
Use:	DOMESTIC		
Owner name:	GARETT, JIMMY		
Section:	05	Township:	08S
Range:	11W		
Latdd:	30.3708		
Longdd:	-89.1033		
Casing dia:	2		
Casing len:	20		
Screen len:	0		
Well depth:	30		
Site id:	MSC300000044621		



## GEOCHECK® - PHYSICAL SETTING SOURCE MAP FINDINGS

Map ID  
 Direction  
 Distance  
 Elevation

Database      EDR ID Number

**N43**  
**NW**  
**1/2 - 1 Mile**  
**Higher**

**FED USGS      USGS40000608838**

Org. Identifier:	USGS-MS		
Formal name:	USGS Mississippi Water Science Center		
Monloc Identifier:	USGS-302214089061201		
Monloc name:	L0497 HARRISON		
Monloc type:	Well		
Monloc desc:	Not Reported		
Huc code:	03170009	Drainagearea value:	Not Reported
Drainagearea Units:	Not Reported	Contrib drainagearea:	Not Reported
Contrib drainagearea units:	Not Reported	Latitude:	30.370753
Longitude:	-89.1033715	Sourcemap scale:	Not Reported
Horiz Acc measure:	5	Horiz Acc measure units:	seconds
Horiz Collection method:	Interpolated from map		
Horiz coord refsys:	NAD83	Vert measure val:	10.00
Vert measure units:	feet	Vertacc measure val:	10
Vert accmeasure units:	feet		
Vertcollection method:	Unknown		
Vert coord refsys:	NGVD29	Countrycode:	US
Aquifername:	Coastal lowlands aquifer system		
Formation type:	Citronelle Formation		
Aquifer type:	Not Reported		
Construction date:	19770516	Welldepth:	30
Welldepth units:	ft	Wellholedepth:	30
Wellholedepth units:	ft		

Ground-water levels, Number of Measurements: 1

Date	Feet below Surface	Feet to Sealevel
-----		
1977-05-16	4.00	

**N44**  
**NW**  
**1/2 - 1 Mile**  
**Higher**

**MS WELLS      MSPR30000001005**

Latn:	302214	Longn:	890612
Local no:	L497	Use 1:	H
Aquifer:	121CRNL	Depth:	30
County:	HARRISON	Fips:	47
Site id:	MSPR30000001005		

**O45**  
**SE**  
**1/2 - 1 Mile**  
**Lower**

**MS WELLS      MSC300000044316**

## GEOCHECK® - PHYSICAL SETTING SOURCE MAP FINDINGS

Fid:	44316	County nam:	HARRISON
Permit num:	Not Reported	Fip well:	047L0172
Doh number:	Not Reported	Aquifer:	GRAHAM FERRY
Use:	UNUSED		
Owner name:	GULFPORT HARBOR		
Section:	09	Township:	08S
Range:	11W		
Latdd:	30.3575		
Longdd:	-89.0881		
Casing dia:	4		
Casing len:	0		
Screen len:	0		
Well depth:	800		
Site id:	MSC300000044316		

**O46  
SE  
1/2 - 1 Mile  
Lower**

**FED USGS      USGS4000608507**

Org. Identifier:	USGS-MS		
Formal name:	USGS Mississippi Water Science Center		
Monloc Identifier:	USGS-302127089051901		
Monloc name:	L0172 HARRISON		
Monloc type:	Well		
Monloc desc:	Not Reported		
Huc code:	03170009	Drainagearea value:	Not Reported
Drainagearea Units:	Not Reported	Contrib drainagearea:	Not Reported
Contrib drainagearea units:	Not Reported	Latitude:	30.3574201
Longitude:	-89.0880929	Sourcemap scale:	Not Reported
Horiz Acc measure:	1	Horiz Acc measure units:	seconds
Horiz Collection method:	Interpolated from map		
Horiz coord refsys:	NAD83	Vert measure val:	10.00
Vert measure units:	feet	Vertacc measure val:	.1
Vert accmeasure units:	feet		
Vertcollection method:	Level or other surveying method		
Vert coord refsys:	NGVD29	Countrycode:	US
Aquifername:	Coastal lowlands aquifer system		
Formation type:	Graham Ferry Formation		
Aquifer type:	Not Reported		
Construction date:	19160101	Welldepth:	800
Welldepth units:	ft	Wellholedepth:	Not Reported
Wellholedepth units:	Not Reported		

Ground-water levels, Number of Measurements: 68

Date	Feet below Surface	Feet to Sealevel	Date	Feet below Surface	Feet to Sealevel
1982-10-28	20.39		1978-04-11	5.38	
1977-04-20	5.07		1974-11-06	5.80	
1974-07-16	5.00		1973-10-24	2.10	
1973-07-26	4.80		1973-04-24	-0.35	
1973-02-01	-0.06		1972-11-29	2.00	
1972-10-20	-3.20		1972-07-11	0.60	
1972-04-14	-8.60		1972-01-13	-7.00	
1971-10-22	-5.00		1971-04-28	-8.00	
1971-01-05	-13.00		1970-10-21	-12.00	
1970-07-22	-3.00		1970-04-22	-9.00	

## GEOCHECK® - PHYSICAL SETTING SOURCE MAP FINDINGS

Ground-water levels, continued.

Date	Feet below Surface	Feet to Sealevel	Date	Feet below Surface	Feet to Sealevel
1970-01-07	-6.00		1969-10-08	-4.50	
1969-08-20	-4.50		1969-06-03	-5.00	
1969-05-15	-9.00		1968-11-22	-7.00	
1968-08-07	-6.00		1968-04-10	-13.00	
1968-01-09	-12.50		1967-10-03	-10.70	
1967-04-19	-13.00		1967-01-11	-13.00	
1966-10-07	-11.00		1966-07-06	-11.00	
1966-03-31	-14.00		1966-01-04	-14.00	
1965-09-30	-9.00		1965-04-13	-12.10	
1965-01-20	-12.10		1964-10-20	-14.50	
1964-07-14	-13.00		1964-05-22	-20.50	
1964-01-22	-18.00		1963-10-21	-16.50	
1963-07-24	-16.30		1963-04-22	-20.10	
1963-01-16	-14.90		1962-11-07	-18.70	
1962-07-25	-16.60		1962-04-18	-20.00	
1962-01-31	-15.80		1961-10-26	-18.20	
1961-07-26	-19.00		1961-04-19	-21.50	
1961-01-25	-20.60		1960-11-01	-19.00	
1960-04-20	-18.00		1959-07-14	-22.00	
1959-03-05	-21.20		1958-12-10	-23.50	
1958-08-18	-22.40		1958-08-01	-19.00	
1957-11-12	-24.00		1957-06-17	-15.50	
1956-11-09	-18.10		1956-10-18	-24.00	
1956-08-23	-21.80		1956-06-20	-23.20	

**N47  
NW  
1/2 - 1 Mile  
Higher**

**MS WELLS      MSPR30000001024**

Latn:	302217	Longn:	890614
Local no:	L621	Use 1:	H
Aquifer:	121CRNL	Depth:	30
County:	HARRISON	Fips:	47
Site id:	MSPR30000001024		

**N48  
NW  
1/2 - 1 Mile  
Higher**

**FED USGS      USGS40000608873**

Org. Identifier:	USGS-MS	Drainagearea value:	Not Reported
Formal name:	USGS Mississippi Water Science Center	Contrib drainagearea:	Not Reported
Monloc Identifier:	USGS-302217089061401	Latitude:	30.3715863
Monloc name:	L0621 HARRISON	Sourcemap scale:	Not Reported
Monloc type:	Well		
Monloc desc:	Not Reported		
Huc code:	03170009		
Drainagearea Units:	Not Reported		
Contrib drainagearea units:	Not Reported		
Longitude:	-89.103927		

## GEOCHECK® - PHYSICAL SETTING SOURCE MAP FINDINGS

Horiz Acc measure:	5	Horiz Acc measure units:	seconds
Horiz Collection method:	Interpolated from map		
Horiz coord refsys:	NAD83	Vert measure val:	25.0
Vert measure units:	feet	Vertacc measure val:	10
Vert accmeasure units:	feet		
Vertcollection method:	Unknown		
Vert coord refsys:	NGVD29	Countrycode:	US
Aquifername:	Coastal lowlands aquifer system		
Formation type:	Citronelle Formation		
Aquifer type:	Not Reported		
Construction date:	19830331	Welldepth:	30
Welldepth units:	ft	Wellholedepth:	30
Wellholedepth units:	ft		

Ground-water levels, Number of Measurements: 1

Date	Feet below Surface	Feet to Sealevel
-----		
1983-03-31	5.00	

**N49  
NW  
1/2 - 1 Mile  
Higher**

**MS WELLS    MSC300000044745**

Fid:	44745	County nam:	HARRISON
Permit num:	Not Reported	Fip well:	047L0621
Doh number:	Not Reported	Aquifer:	CITRONELLE
Use:	DOMESTIC		
Owner name:	PARKERSON, G A		
Section:	05	Township:	07S
Range:	11W		
Latdd:	30.3717		
Longdd:	-89.1039		
Casing dia:	2		
Casing len:	20		
Screen len:	0		
Well depth:	30		
Site id:	MSC300000044745		

**P50  
West  
1/2 - 1 Mile  
Higher**

**MS WELLS    MSC300000044786**

Fid:	44786	County nam:	HARRISON
Permit num:	Not Reported	Fip well:	047L0666
Doh number:	Not Reported	Aquifer:	Not Reported
Use:	DOMESTIC		
Owner name:	GULFPORT, CITY OF		
Section:	08	Township:	08S
Range:	11W		
Latdd:	30.3661		
Longdd:	-89.1075		
Casing dia:	0		

# GEOCHECK® - PHYSICAL SETTING SOURCE MAP FINDINGS

Casing len: 0  
 Screen len: 0  
 Well depth: 0  
 Site id: MSC300000044786

**P51**  
**West**  
**1/2 - 1 Mile**  
**Higher**

**FED USGS USGS40000608717**

Org. Identifier:	USGS-MS		
Formal name:	USGS Mississippi Water Science Center		
Monloc Identifier:	USGS-302157089062701		
Monloc name:	L0666 HARRISON		
Monloc type:	Well: Test hole not completed as a well		
Monloc desc:	Not Reported		
Huc code:	03170009	Drainagearea value:	Not Reported
Drainagearea Units:	Not Reported	Contrib drainagearea:	Not Reported
Contrib drainagearea units:	Not Reported	Latitude:	30.3660308
Longitude:	-89.1075382	Sourcemap scale:	Not Reported
Horiz Acc measure:	1	Horiz Acc measure units:	minutes
Horiz Collection method:	Interpolated from map		
Horiz coord refsys:	NAD83	Vert measure val:	26.
Vert measure units:	feet	Vertacc measure val:	5.
Vert accmeasure units:	feet		
Vertcollection method:	Interpolated from topographic map		
Vert coord refsys:	NGVD29	Countrycode:	US
Aquifername:	Not Reported		
Formation type:	Not Reported		
Aquifer type:	Not Reported		
Construction date:	19880502	Welldepth:	Not Reported
Welldepth units:	Not Reported	Wellholedepth:	460
Wellholedepth units:	ft		

Ground-water levels, Number of Measurements: 0

**P52**  
**West**  
**1/2 - 1 Mile**  
**Higher**

**MS WELLS MSPR30000000937**

Latn:	302157	Longn:	890627
Local no:	L666	Use 1:	H
Aquifer:	Not Reported	Depth:	0
County:	HARRISON	Fips:	47
Site id:	MSPR30000000937		

**Q53**  
**North**  
**1/2 - 1 Mile**  
**Higher**

**FED USGS USGS40000608975**

## GEOCHECK® - PHYSICAL SETTING SOURCE MAP FINDINGS

Org. Identifier:	USGS-MS		
Formal name:	USGS Mississippi Water Science Center		
Monloc Identifier:	USGS-302228089054001		
Monloc name:	L0156 HARRISON		
Monloc type:	Well		
Monloc desc:	Not Reported		
Huc code:	03170009	Drainagearea value:	Not Reported
Drainagearea Units:	Not Reported	Contrib drainagearea:	Not Reported
Contrib drainagearea units:	Not Reported	Latitude:	30.3746419
Longitude:	-89.0944823	Sourcemap scale:	Not Reported
Horiz Acc measure:	10	Horiz Acc measure units:	seconds
Horiz Collection method:	Interpolated from map		
Horiz coord refsys:	NAD83	Vert measure val:	23.00
Vert measure units:	feet	Vertacc measure val:	.5
Vert accmeasure units:	feet		
Vertcollection method:	Level or other surveying method		
Vert coord refsys:	NGVD29	Countrycode:	US
Aquifername:	Coastal lowlands aquifer system		
Formation type:	Graham Ferry Formation		
Aquifer type:	Not Reported		
Construction date:	19250101	Welldepth:	771
Welldepth units:	ft	Wellholedepth:	Not Reported
Wellholedepth units:	Not Reported		

Ground-water levels, Number of Measurements: 1

Date	Feet below Surface	Feet to Sealevel
-----		
1939-03-01	-22.00	

**Q54**  
**North**  
**1/2 - 1 Mile**  
**Higher**

**MS WELLS      MSC300000044305**

Fid:	44305	County nam:	HARRISON
Permit num:	Not Reported	Fip well:	047L0156
Doh number:	Not Reported	Aquifer:	GRAHAM FERRY
Use:	UNUSED		
Owner name:	SO MS ICE CO		
Section:	09	Township:	08S
Range:	11W		
Latdd:	30.3747		
Longdd:	-89.0944		
Casing dia:	4		
Casing len:	0		
Screen len:	0		
Well depth:	771		
Site id:	MSC300000044305		

**R55**  
**NNE**  
**1/2 - 1 Mile**  
**Higher**

**FED USGS      USGS40000608974**

## GEOCHECK® - PHYSICAL SETTING SOURCE MAP FINDINGS

Org. Identifier:	USGS-MS		
Formal name:	USGS Mississippi Water Science Center		
Monloc Identifier:	USGS-302228089053501		
Monloc name:	L0155 HARRISON		
Monloc type:	Well		
Monloc desc:	Not Reported		
Huc code:	03170009	Drainagearea value:	Not Reported
Drainagearea Units:	Not Reported	Contrib drainagearea:	Not Reported
Contrib drainagearea units:	Not Reported	Latitude:	30.3746419
Longitude:	-89.0930933	Sourcemap scale:	Not Reported
Horiz Acc measure:	10	Horiz Acc measure units:	seconds
Horiz Collection method:	Interpolated from map		
Horiz coord refsys:	NAD83	Vert measure val:	23.00
Vert measure units:	feet	Vertacc measure val:	.5
Vert accmeasure units:	feet		
Vertcollection method:	Level or other surveying method		
Vert coord refsys:	NGVD29	Countrycode:	US
Aquifername:	Coastal lowlands aquifer system		
Formation type:	Graham Ferry Formation		
Aquifer type:	Not Reported		
Construction date:	19030101	Welldepth:	840
Welldepth units:	ft	Wellholedepth:	Not Reported
Wellholedepth units:	Not Reported		

Ground-water levels, Number of Measurements: 1

Date	Feet below Surface	Feet to Sealevel
-----		
1939-03-01	-20.00	

**R56**  
**NNE**  
**1/2 - 1 Mile**  
**Higher**

**MS WELLS      MSC300000044304**

Fid:	44304	County nam:	HARRISON
Permit num:	Not Reported	Fip well:	047L0155
Doh number:	Not Reported	Aquifer:	GRAHAM FERRY
Use:	UNUSED		
Owner name:	SO MS ICE CO		
Section:	09	Township:	08S
Range:	11W		
Latdd:	30.3747		
Longdd:	-89.0931		
Casing dia:	4		
Casing len:	0		
Screen len:	0		
Well depth:	840		
Site id:	MSC300000044304		

**Q57**  
**North**  
**1/2 - 1 Mile**  
**Higher**

**FED USGS      USGS40000608998**

## GEOCHECK® - PHYSICAL SETTING SOURCE MAP FINDINGS

Org. Identifier:	USGS-MS		
Formal name:	USGS Mississippi Water Science Center		
Monloc Identifier:	USGS-302230089054401		
Monloc name:	L0003 HARRISON		
Monloc type:	Well		
Monloc desc:	Not Reported		
Huc code:	03170009	Drainagearea value:	Not Reported
Drainagearea Units:	Not Reported	Contrib drainagearea:	Not Reported
Contrib drainagearea units:	Not Reported	Latitude:	30.3751975
Longitude:	-89.0955934	Sourcemap scale:	Not Reported
Horiz Acc measure:	10	Horiz Acc measure units:	seconds
Horiz Collection method:	Interpolated from map		
Horiz coord refsys:	NAD83	Vert measure val:	25.
Vert measure units:	feet	Vertacc measure val:	10
Vert accmeasure units:	feet		
Vertcollection method:	Interpolated from topographic map		
Vert coord refsys:	NGVD29	Countrycode:	US
Aquifername:	Coastal lowlands aquifer system		
Formation type:	Pascagoula Formation		
Aquifer type:	Not Reported		
Construction date:	19580101	Welldepth:	783
Welldepth units:	ft	Wellholedepth:	Not Reported
Wellholedepth units:	Not Reported		

Ground-water levels, Number of Measurements: 0

**Q58**  
**North**  
**1/2 - 1 Mile**  
**Higher**

**MS WELLS      MSPR30000001095**

Latn:	302230	Longn:	890544
Local no:	L003	Use 1:	H
Aquifer:	122PCGL	Depth:	783
County:	HARRISON	Fips:	47
Site id:	MSPR30000001095		

**Q59**  
**North**  
**1/2 - 1 Mile**  
**Higher**

**MS WELLS      MSC300000044159**

Fid:	44159	County nam:	HARRISON
Permit num:	Not Reported	Fip well:	047L0003
Doh number:	Not Reported	Aquifer:	PASCAGOULA
Use:	DOMESTIC		
Owner name:	BARRETT, JACK		
Section:	09	Township:	08S
Range:	11W		
Latdd:	30.3753		
Longdd:	-89.0956		
Casing dia:	4		
Casing len:	0		
Screen len:	0		
Well depth:	783		
Site id:	MSC300000044159		



## GEOCHECK® - PHYSICAL SETTING SOURCE MAP FINDINGS

Map ID  
 Direction  
 Distance  
 Elevation

Database      EDR ID Number

**Q60**  
**North**  
**1/2 - 1 Mile**  
**Higher**

**FED USGS      USGS40000609015**

Org. Identifier:	USGS-MS		
Formal name:	USGS Mississippi Water Science Center		
Monloc Identifier:	USGS-302231089054001		
Monloc name:	L0150 HARRISON		
Monloc type:	Well		
Monloc desc:	Not Reported		
Huc code:	03170009	Drainagearea value:	Not Reported
Drainagearea Units:	Not Reported	Contrib drainagearea:	Not Reported
Contrib drainagearea units:	Not Reported	Latitude:	30.3754752
Longitude:	-89.0944823	Sourcemap scale:	Not Reported
Horiz Acc measure:	10	Horiz Acc measure units:	seconds
Horiz Collection method:	Interpolated from map		
Horiz coord refsys:	NAD83	Vert measure val:	13.00
Vert measure units:	feet	Vertacc measure val:	.5
Vert accmeasure units:	feet		
Vertcollection method:	Level or other surveying method		
Vert coord refsys:	NGVD29	Countrycode:	US
Aquifername:	Coastal lowlands aquifer system		
Formation type:	Pascagoula Formation		
Aquifer type:	Not Reported		
Construction date:	19100101	Welldepth:	1173
Welldepth units:	ft	Wellholedepth:	Not Reported
Wellholedepth units:	Not Reported		

Ground-water levels, Number of Measurements: 1

Date	Feet below Surface	Feet to Sealevel
-----		
1910-08-01	-65.00	

**Q61**  
**North**  
**1/2 - 1 Mile**  
**Higher**

**MS WELLS      MSC300000044299**

Fid:	44299	County nam:	HARRISON
Permit num:	Not Reported	Fip well:	047L0150
Doh number:	Not Reported	Aquifer:	PASCAGOULA
Use:	UNUSED		
Owner name:	GULFPORT, CITY OF		
Section:	04	Township:	08S
Range:	11W		
Latdd:	30.3756		
Longdd:	-89.0944		
Casing dia:	8		
Casing len:	0		
Screen len:	0		
Well depth:	1173		
Site id:	MSC300000044299		

## GEOCHECK® - PHYSICAL SETTING SOURCE MAP FINDINGS

Map ID  
Direction  
Distance  
Elevation

Database      EDR ID Number

**S62**  
**West**  
**1/2 - 1 Mile**  
**Higher**

**MS WELLS      MSC300000044779**

Fid:	44779	County nam:	HARRISON
Permit num:	Not Reported	Fip well:	047L0659
Doh number:	Not Reported	Aquifer:	CITRONELLE
Use:	DOMESTIC		
Owner name:	BROOME, V B		
Section:	08	Township:	08S
Range:	11W		
Latdd:	30.3622		
Longdd:	-89.1089		
Casing dia:	2		
Casing len:	20		
Screen len:	0		
Well depth:	30		
Site id:	MSC300000044779		

**T63**  
**SSE**  
**1/2 - 1 Mile**  
**Lower**

**MS WELLS      MSC300000044319**

Fid:	44319	County nam:	HARRISON
Permit num:	Not Reported	Fip well:	047L0175
Doh number:	Not Reported	Aquifer:	LOWER PASCAGOULA
Use:	FIRE PROTECTION		
Owner name:	MISSISSIPPI STATE PORT AUTHORITY		
Section:	09	Township:	08S
Range:	11W		
Latdd:	30.3531		
Longdd:	-89.0925		
Casing dia:	8		
Casing len:	1260		
Screen len:	1320		
Well depth:	1320		
Site id:	MSC300000044319		

**S64**  
**West**  
**1/2 - 1 Mile**  
**Higher**

**MS WELLS      MSPR30000000878**

Latn:	302143	Longn:	890632
Local no:	L659	Use 1:	H
Aquifer:	121CRNL	Depth:	30
County:	HARRISON	Fips:	47
Site id:	MSPR30000000878		

# GEOCHECK® - PHYSICAL SETTING SOURCE MAP FINDINGS

Map ID  
 Direction  
 Distance  
 Elevation

Database      EDR ID Number

**S65**  
**West**  
**1/2 - 1 Mile**  
**Higher**

**FED USGS      USGS40000608622**

Org. Identifier:	USGS-MS				
Formal name:	USGS Mississippi Water Science Center				
Monloc Identifier:	USGS-302143089063201				
Monloc name:	L0659 HARRISON				
Monloc type:	Well				
Monloc desc:	Not Reported				
Huc code:	03170009	Drainagearea value:	Not Reported		
Drainagearea Units:	Not Reported	Contrib drainagearea:	Not Reported		
Contrib drainagearea units:	Not Reported	Latitude:	30.362142		
Longitude:	-89.1089271	Sourcemap scale:	Not Reported		
Horiz Acc measure:	5	Horiz Acc measure units:	seconds		
Horiz Collection method:	Interpolated from map				
Horiz coord refsys:	NAD83	Vert measure val:	17.00		
Vert measure units:	feet	Vertacc measure val:	10		
Vert accmeasure units:	feet				
Vertcollection method:	Unknown				
Vert coord refsys:	NGVD29	Countrycode:	US		
Aquifername:	Coastal lowlands aquifer system				
Formation type:	Citronelle Formation				
Aquifer type:	Not Reported				
Construction date:	19850503	Welldepth:	30		
Welldepth units:	ft	Wellholedepth:	30		
Wellholedepth units:	ft				

Ground-water levels, Number of Measurements: 1

	Feet below	Feet to
Date	Surface	Sealevel
-----		
1985-05-03	10.00	

**U66**  
**West**  
**1/2 - 1 Mile**  
**Higher**

**MS WELLS      MSC300000044575**

Fid:	44575	County nam:	HARRISON		
Permit num:	Not Reported	Fip well:	047L0451		
Doh number:	Not Reported	Aquifer:	CITRONELLE		
Use:	DOMESTIC				
Owner name:	ACADIAN VILLAGE CONDO				
Section:	08	Township:	08S		
Range:	11W				
Latdd:	30.3639				
Longdd:	-89.1092				
Casing dia:	4				
Casing len:	120				
Screen len:	0				
Well depth:	140				
Site id:	MSC300000044575				

# GEOCHECK® - PHYSICAL SETTING SOURCE MAP FINDINGS

Map ID  
 Direction  
 Distance  
 Elevation

Database      EDR ID Number

**U67**  
**West**  
**1/2 - 1 Mile**  
**Higher**

**FED USGS      USGS40000608682**

Org. Identifier:	USGS-MS		
Formal name:	USGS Mississippi Water Science Center		
Monloc Identifier:	USGS-302149089063301		
Monloc name:	L0451 HARRISON		
Monloc type:	Well		
Monloc desc:	Not Reported		
Huc code:	03170009	Drainagearea value:	Not Reported
Drainagearea Units:	Not Reported	Contrib drainagearea:	Not Reported
Contrib drainagearea units:	Not Reported	Latitude:	30.3638086
Longitude:	-89.1092049	Sourcemap scale:	Not Reported
Horiz Acc measure:	5	Horiz Acc measure units:	seconds
Horiz Collection method:	Interpolated from map		
Horiz coord refsys:	NAD83	Vert measure val:	20.00
Vert measure units:	feet	Vertacc measure val:	10
Vert accmeasure units:	feet		
Vertcollection method:	Unknown		
Vert coord refsys:	NGVD29	Countrycode:	US
Aquifername:	Coastal lowlands aquifer system		
Formation type:	Citronelle Formation		
Aquifer type:	Not Reported		
Construction date:	19820604	Welldepth:	140
Welldepth units:	ft	Wellholedepth:	140
Wellholedepth units:	ft		

Ground-water levels, Number of Measurements: 1

	Feet below	Feet to
Date	Surface	Sealevel
-----		
1982-06-04	12.00	

**U68**  
**West**  
**1/2 - 1 Mile**  
**Higher**

**MS WELLS      MSPR30000000920**

Latn:	302149	Longn:	890633
Local no:	L451	Use 1:	H
Aquifer:	121CRNL	Depth:	140
County:	HARRISON	Fips:	47
Site id:	MSPR30000000920		

**T69**  
**SSE**  
**1/2 - 1 Mile**  
**Lower**

**FED USGS      USGS40000608417**

# GEOCHECK® - PHYSICAL SETTING SOURCE MAP FINDINGS

Org. Identifier:	USGS-MS		
Formal name:	USGS Mississippi Water Science Center		
Monloc Identifier:	USGS-302110089053301		
Monloc name:	L0175 HARRISON		
Monloc type:	Well		
Monloc desc:	Not Reported		
Huc code:	03170009	Drainagearea value:	Not Reported
Drainagearea Units:	Not Reported	Contrib drainagearea:	Not Reported
Contrib drainagearea units:	Not Reported	Latitude:	30.3527778
Longitude:	-89.0925	Sourcemap scale:	Not Reported
Horiz Acc measure:	1	Horiz Acc measure units:	seconds
Horiz Collection method:	Global positioning system (GPS), uncorrected		
Horiz coord refsys:	NAD83	Vert measure val:	5.
Vert measure units:	feet	Vertacc measure val:	5.
Vert accmeasure units:	feet		
Vertcollection method:	Interpolated from topographic map		
Vert coord refsys:	NAVD88	Countrycode:	US
Aquifername:	Coastal lowlands aquifer system		
Formation type:	Pascagoula Formation		
Aquifer type:	Not Reported		
Construction date:	19680101	Welldepth:	1320
Welldepth units:	ft	Wellholedepth:	Not Reported
Wellholedepth units:	Not Reported		

Ground-water levels, Number of Measurements: 1

Date	Feet below Surface	Feet to Sealevel
-----		
1968-09-01	-9.00	

**T70**  
**SSE**  
**1/2 - 1 Mile**  
**Lower**

**MS WELLS      MSP30000000053**

Cnty:	47	Aquifer:	GRMF
Latn:	302110	Longn:	890531
Use 1:	FP	Source:	GRAHAM FERRY AQUIFER
Depth:	1320		
Ownname:	MISS. STATE PORT AUTHORITY		
Applname:	MISS. STATE PORT AUTHORITY		
Site id:	MSP300000000053		

**71**  
**West**  
**1/2 - 1 Mile**  
**Higher**

**MS WELLS      MSC300000045016**

Fid:	45016	County nam:	HARRISON
Permit num:	Not Reported	Fip well:	047L2147
Doh number:	Not Reported	Aquifer:	Not Reported
Use:	DOMESTIC		
Owner name:	VERNON WILDER		
Section:	08	Township:	08S
Range:	11W		
Latdd:	30.365		
Longdd:	-89.1103		
Casing dia:	2		

## GEOCHECK® - PHYSICAL SETTING SOURCE MAP FINDINGS

Casing len: 20  
 Screen len: 10  
 Well depth: 30  
 Site id: MSC300000045016

**V72**  
**North**  
**1/2 - 1 Mile**  
**Higher**

**MS WELLS      MSC300000045046**

Fid:	45046	County nam:	HARRISON
Permit num:	Not Reported	Fip well:	047L2178
Doh number:	Not Reported	Aquifer:	Not Reported
Use:	DOMESTIC		
Owner name:	JOYNER, DOUGLAS		
Section:	04	Township:	08S
Range:	11W		
Latdd:	30.3781		
Longdd:	-89.0956		
Casing dia:	2		
Casing len:	390		
Screen len:	10		
Well depth:	400		
Site id:	MSC300000045046		

**V73**  
**North**  
**1/2 - 1 Mile**  
**Higher**

**MS WELLS      MSC300000045071**

Fid:	45071	County nam:	HARRISON
Permit num:	Not Reported	Fip well:	047L2208
Doh number:	Not Reported	Aquifer:	Not Reported
Use:	DOMESTIC		
Owner name:	LUTILLIE STEPHY		
Section:	04	Township:	08S
Range:	11W		
Latdd:	30.3781		
Longdd:	-89.0956		
Casing dia:	2		
Casing len:	20		
Screen len:	10		
Well depth:	30		
Site id:	MSC300000045071		

**V74**  
**North**  
**1/2 - 1 Mile**  
**Higher**

**MS WELLS      MSC300000045075**

Fid:	45075	County nam:	HARRISON
Permit num:	Not Reported	Fip well:	047L2212
Doh number:	Not Reported	Aquifer:	Not Reported
Use:	DOMESTIC		
Owner name:	ST PIERRE, MARY		
Section:	04	Township:	08S
Range:	11W		
Latdd:	30.3781		
Longdd:	-89.0956		
Casing dia:	2		

# GEOCHECK® - PHYSICAL SETTING SOURCE MAP FINDINGS

Casing len: 20  
 Screen len: 10  
 Well depth: 30  
 Site id: MSC300000045075

**W75**  
**NE**  
**1/2 - 1 Mile**  
**Higher**

**FED USGS      USGS40000608935**

Org. Identifier:	USGS-MS		
Formal name:	USGS Mississippi Water Science Center		
Monloc Identifier:	USGS-302224089050006		
Monloc name:	L0147 HARRISON		
Monloc type:	Well		
Monloc desc:	Not Reported		
Huc code:	03170009	Drainagearea value:	Not Reported
Drainagearea Units:	Not Reported	Contrib drainagearea:	Not Reported
Contrib drainagearea units:	Not Reported	Latitude:	30.3735309
Longitude:	-89.0833707	Sourcemap scale:	Not Reported
Horiz Acc measure:	1	Horiz Acc measure units:	minutes
Horiz Collection method:	Interpolated from map		
Horiz coord refsys:	NAD83	Vert measure val:	26.
Vert measure units:	feet	Vertacc measure val:	.1
Vert accmeasure units:	feet		
Vertcollection method:	Level or other surveying method		
Vert coord refsys:	NGVD29	Countrycode:	US
Aquifername:	Coastal lowlands aquifer system		
Formation type:	Miocene Series		
Aquifer type:	Not Reported		
Construction date:	19370101	Welldepth:	953
Welldepth units:	ft	Wellholedepth:	Not Reported
Wellholedepth units:	Not Reported		

Ground-water levels, Number of Measurements: 1

Date	Feet below Surface	Feet to Sealevel
-----		
1966-03-01	32.00	

**W76**  
**NE**  
**1/2 - 1 Mile**  
**Higher**

**FED USGS      USGS40000608936**

Org. Identifier:	USGS-MS		
Formal name:	USGS Mississippi Water Science Center		
Monloc Identifier:	USGS-302224089050007		
Monloc name:	L0149 HARRISON		
Monloc type:	Well		
Monloc desc:	Not Reported		
Huc code:	03170009	Drainagearea value:	Not Reported
Drainagearea Units:	Not Reported	Contrib drainagearea:	Not Reported
Contrib drainagearea units:	Not Reported	Latitude:	30.3735309
Longitude:	-89.0833707	Sourcemap scale:	Not Reported

## GEOCHECK® - PHYSICAL SETTING SOURCE MAP FINDINGS

Horiz Acc measure:	10	Horiz Acc measure units:	seconds
Horiz Collection method:	Interpolated from map		
Horiz coord refsys:	NAD83	Vert measure val:	29.
Vert measure units:	feet	Vertacc measure val:	.5
Vert accmeasure units:	feet		
Vertcollection method:	Level or other surveying method		
Vert coord refsys:	NGVD29	Countrycode:	US
Aquifername:	Coastal lowlands aquifer system		
Formation type:	Miocene Series		
Aquifer type:	Not Reported		
Construction date:	19270101	Welldepth:	1242
Welldepth units:	ft	Wellholedepth:	Not Reported
Wellholedepth units:	Not Reported		

Ground-water levels, Number of Measurements: 1

Date	Feet below Surface	Feet to Sealevel
-----		
1966-03-01	6.00	

**W77**  
**NE**  
**1/2 - 1 Mile**  
**Higher**

**MS WELLS    MSC300000044296**

Fid:	44296	County nam:	HARRISON
Permit num:	Not Reported	Fip well:	047L0147
Doh number:	Not Reported	Aquifer:	MIOCENE
Use:	Not Reported		
Owner name:	GULFPORT, CITY OF		
Section:	04	Township:	08S
Range:	11W		
Latdd:	30.3736		
Longdd:	-89.0833		
Casing dia:	10		
Casing len:	0		
Screen len:	0		
Well depth:	953		
Site id:	MSC300000044296		

**W78**  
**NE**  
**1/2 - 1 Mile**  
**Higher**

**MS WELLS    MSC300000044298**

Fid:	44298	County nam:	HARRISON
Permit num:	Not Reported	Fip well:	047L0149
Doh number:	Not Reported	Aquifer:	MIOCENE
Use:	Not Reported		
Owner name:	GULFPORT, CITY OF		
Section:	04	Township:	08S
Range:	11W		
Latdd:	30.3736		
Longdd:	-89.0833		
Casing dia:	12		



# GEOCHECK® - PHYSICAL SETTING SOURCE MAP FINDINGS

Casing len: 0  
 Screen len: 0  
 Well depth: 1242  
 Site id: MSC300000044298

**X79**  
**NNE**  
**1/2 - 1 Mile**  
**Higher**

**FED USGS USGS40000609117**

Org. Identifier:	USGS-MS		
Formal name:	USGS Mississippi Water Science Center		
Monloc Identifier:	USGS-302244089053801		
Monloc name:	L0410 HARRISON		
Monloc type:	Well		
Monloc desc:	Not Reported		
Huc code:	03170009	Drainagearea value:	Not Reported
Drainagearea Units:	Not Reported	Contrib drainagearea:	Not Reported
Contrib drainagearea units:	Not Reported	Latitude:	30.378253
Longitude:	-89.09226	Sourcemap scale:	Not Reported
Horiz Acc measure:	10	Horiz Acc measure units:	seconds
Horiz Collection method:	Interpolated from map		
Horiz coord refsys:	NAD83	Vert measure val:	20.
Vert measure units:	feet	Vertacc measure val:	5.
Vert accmeasure units:	feet		
Vertcollection method:	Interpolated from topographic map		
Vert coord refsys:	NGVD29	Countrycode:	US
Aquifername:	Coastal lowlands aquifer system		
Formation type:	Pascagoula Formation		
Aquifer type:	Not Reported		
Construction date:	19740101	Welldepth:	757
Welldepth units:	ft	Wellholedepth:	Not Reported
Wellholedepth units:	Not Reported		

Ground-water levels, Number of Measurements: 1

Date	Feet below Surface	Feet to Sealevel
-----		
1974-07-01	3.00	

**X80**  
**NNE**  
**1/2 - 1 Mile**  
**Higher**

**MS WELLS MSC300000044541**

Fid:	44541	County nam:	HARRISON
Permit num:	Not Reported	Fip well:	047L0410
Doh number:	Not Reported	Aquifer:	PASCAGOULA
Use:	UNUSED		
Owner name:	LITCHFIELD CO		
Section:	04	Township:	08S
Range:	11W		
Latdd:	30.3783		
Longdd:	-89.0922		
Casing dia:	4		

## GEOCHECK® - PHYSICAL SETTING SOURCE MAP FINDINGS

Casing len: 0  
Screen len: 0  
Well depth: 757  
Site id: MSC300000044541

# GEOCHECK® - PHYSICAL SETTING SOURCE MAP FINDINGS RADON

## AREA RADON INFORMATION

State Database: MS Radon

### Radon Test Results

County	Num Sites	Avg Pci/L	Max Pci/L	Median Pci/L	% > 4 Pci/L	% > 20 Pci/L
HARRISON	40	0.3	2.0	0.3	0	0

Federal EPA Radon Zone for HARRISON County: 3

- Note: Zone 1 indoor average level > 4 pCi/L.  
 : Zone 2 indoor average level >= 2 pCi/L and <= 4 pCi/L.  
 : Zone 3 indoor average level < 2 pCi/L.

Federal Area Radon Information for Zip Code: 39501

Number of sites tested: 1

Area	Average Activity	% <4 pCi/L	% 4-20 pCi/L	% >20 pCi/L
Living Area - 1st Floor	0.400 pCi/L	100%	0%	0%
Living Area - 2nd Floor	Not Reported	Not Reported	Not Reported	Not Reported
Basement	Not Reported	Not Reported	Not Reported	Not Reported

# PHYSICAL SETTING SOURCE RECORDS SEARCHED

## TOPOGRAPHIC INFORMATION

### USGS 7.5' Digital Elevation Model (DEM)

Source: United States Geologic Survey

EDR acquired the USGS 7.5' Digital Elevation Model in 2002 and updated it in 2006. The 7.5 minute DEM corresponds to the USGS 1:24,000- and 1:25,000-scale topographic quadrangle maps. The DEM provides elevation data with consistent elevation units and projection.

### Current USGS 7.5 Minute Topographic Map

Source: U.S. Geological Survey

## HYDROLOGIC INFORMATION

Flood Zone Data: This data, available in select counties across the country, was obtained by EDR in 2003 & 2011 from the Federal Emergency Management Agency (FEMA). Data depicts 100-year and 500-year flood zones as defined by FEMA.

NWI: National Wetlands Inventory. This data, available in select counties across the country, was obtained by EDR in 2002, 2005 and 2010 from the U.S. Fish and Wildlife Service.

## HYDROGEOLOGIC INFORMATION

### AQUIFLOW<sup>R</sup> Information System

Source: EDR proprietary database of groundwater flow information

EDR has developed the AQUIFLOW Information System (AIS) to provide data on the general direction of groundwater flow at specific points. EDR has reviewed reports submitted to regulatory authorities at select sites and has extracted the date of the report, hydrogeologically determined groundwater flow direction and depth to water table information.

## GEOLOGIC INFORMATION

### Geologic Age and Rock Stratigraphic Unit

Source: P.G. Schruben, R.E. Arndt and W.J. Bawiec, Geology of the Conterminous U.S. at 1:2,500,000 Scale - A digital representation of the 1974 P.B. King and H.M. Beikman Map, USGS Digital Data Series DDS - 11 (1994).

### STATSGO: State Soil Geographic Database

Source: Department of Agriculture, Natural Resources Conservation Services

The U.S. Department of Agriculture's (USDA) Natural Resources Conservation Service (NRCS) leads the national Conservation Soil Survey (NCSS) and is responsible for collecting, storing, maintaining and distributing soil survey information for privately owned lands in the United States. A soil map in a soil survey is a representation of soil patterns in a landscape. Soil maps for STATSGO are compiled by generalizing more detailed (SSURGO) soil survey maps.

### SSURGO: Soil Survey Geographic Database

Source: Department of Agriculture, Natural Resources Conservation Services (NRCS)

Telephone: 800-672-5559

SSURGO is the most detailed level of mapping done by the Natural Resources Conservation Services, mapping scales generally range from 1:12,000 to 1:63,360. Field mapping methods using national standards are used to construct the soil maps in the Soil Survey Geographic (SSURGO) database. SSURGO digitizing duplicates the original soil survey maps. This level of mapping is designed for use by landowners, townships and county natural resource planning and management.

# PHYSICAL SETTING SOURCE RECORDS SEARCHED

## LOCAL / REGIONAL WATER AGENCY RECORDS

### FEDERAL WATER WELLS

#### PWS: Public Water Systems

Source: EPA/Office of Drinking Water

Telephone: 202-564-3750

Public Water System data from the Federal Reporting Data System. A PWS is any water system which provides water to at least 25 people for at least 60 days annually. PWSs provide water from wells, rivers and other sources.

#### PWS ENF: Public Water Systems Violation and Enforcement Data

Source: EPA/Office of Drinking Water

Telephone: 202-564-3750

Violation and Enforcement data for Public Water Systems from the Safe Drinking Water Information System (SDWIS) after August 1995. Prior to August 1995, the data came from the Federal Reporting Data System (FRDS).

#### USGS Water Wells: USGS National Water Inventory System (NWIS)

This database contains descriptive information on sites where the USGS collects or has collected data on surface water and/or groundwater. The groundwater data includes information on wells, springs, and other sources of groundwater.

### STATE RECORDS

#### Health Department Wells

Source: Mississippi Automated Resource Information System Technical Center

Telephone: 601-432-6149

Public supply water wells monitored by the Environmental Division of the Department of Health.

#### Permitted Wells

Source: Mississippi Automated Resource Information System Technical Center

Telephone: 601-432-6149

Water wells, 6-inches in diameter or larger that are permitted and monitored by the Office of Land and Water Resources.

#### USGS Private Wells

Source: Mississippi Automated Resource Information System Technical Center

Telephone: 601-432-6149

Privately owned water wells monitored by the USGS.

#### USGS Public Wells

Source: Mississippi Automated Resource Information System Technical Center

Telephone: 601-432-6149

Publicly owned water wells monitored by the USGS.

## OTHER STATE DATABASE INFORMATION

### Oil and Gas Well Location Listing

Source: Mississippi Oil and Gas Board

Telephone: 601-354-7119

### RADON

#### State Database: MS Radon

Source: Department of Health

Telephone: 601-987-6893

Radon Levels

#### Area Radon Information

Source: USGS

Telephone: 703-356-4020

The National Radon Database has been developed by the U.S. Environmental Protection Agency (USEPA) and is a compilation of the EPA/State Residential Radon Survey and the National Residential Radon Survey. The study covers the years 1986 - 1992. Where necessary data has been supplemented by information collected at private sources such as universities and research institutions.

## PHYSICAL SETTING SOURCE RECORDS SEARCHED

### EPA Radon Zones

Source: EPA

Telephone: 703-356-4020

Sections 307 & 309 of IRAA directed EPA to list and identify areas of U.S. with the potential for elevated indoor radon levels.

### OTHER

Airport Landing Facilities: Private and public use landing facilities

Source: Federal Aviation Administration, 800-457-6656

Epicenters: World earthquake epicenters, Richter 5 or greater

Source: Department of Commerce, National Oceanic and Atmospheric Administration

Earthquake Fault Lines: The fault lines displayed on EDR's Topographic map are digitized quaternary faultlines, prepared in 1975 by the United State Geological Survey

### STREET AND ADDRESS INFORMATION

© 2010 Tele Atlas North America, Inc. All rights reserved. This material is proprietary and the subject of copyright protection and other intellectual property rights owned by or licensed to Tele Atlas North America, Inc. The use of this material is subject to the terms of a license agreement. You will be held liable for any unauthorized copying or disclosure of this material.



**Port of Gulfport**

2900 West Beach Blvd  
Gulfport, MS 39501

Inquiry Number: 3058388.6  
May 10, 2011



# The EDR-City Directory Abstract

## TABLE OF CONTENTS

### SECTION

Executive Summary

Findings

*Thank you for your business.*  
Please contact EDR at 1-800-352-0050  
with any questions or comments.

#### **Disclaimer - Copyright and Trademark Notice**

This Report contains certain information obtained from a variety of public and other sources reasonably available to Environmental Data Resources, Inc. It cannot be concluded from this Report that coverage information for the target and surrounding properties does not exist from other sources. **NO WARRANTY EXPRESSED OR IMPLIED, IS MADE WHATSOEVER IN CONNECTION WITH THIS REPORT. ENVIRONMENTAL DATA RESOURCES, INC. SPECIFICALLY DISCLAIMS THE MAKING OF ANY SUCH WARRANTIES, INCLUDING WITHOUT LIMITATION, MERCHANTABILITY OR FITNESS FOR A PARTICULAR USE OR PURPOSE. ALL RISK IS ASSUMED BY THE USER. IN NO EVENT SHALL ENVIRONMENTAL DATA RESOURCES, INC. BE LIABLE TO ANYONE, WHETHER ARISING OUT OF ERRORS OR OMISSIONS, NEGLIGENCE, ACCIDENT OR ANY OTHER CAUSE, FOR ANY LOSS OR DAMAGE, INCLUDING, WITHOUT LIMITATION, SPECIAL, INCIDENTAL, CONSEQUENTIAL, OR EXEMPLARY DAMAGES. ANY LIABILITY ON THE PART OF ENVIRONMENTAL DATA RESOURCES, INC. IS STRICTLY LIMITED TO A REFUND OF THE AMOUNT PAID FOR THIS REPORT.** Purchaser accepts this Report "AS IS". Any analyses, estimates, ratings, environmental risk levels or risk codes provided in this Report are provided for illustrative purposes only, and are not intended to provide, nor should they be interpreted as providing any facts regarding, or prediction or forecast of, any environmental risk for any property. Only a Phase I Environmental Site Assessment performed by an environmental professional can provide information regarding the environmental risk for any property. Additionally, the information provided in this Report is not to be construed as legal advice.

Copyright 2009 by Environmental Data Resources, Inc. All rights reserved. Reproduction in any media or format, in whole or in part, of any report or map of Environmental Data Resources, Inc. or its affiliates is prohibited without prior written permission.

EDR and its logos (including Sanborn and Sanborn Map) are trademarks of Environmental Data Resources, Inc. or its affiliates. All other trademarks used herein are the property of their respective owners.



## EXECUTIVE SUMMARY

### DESCRIPTION

Environmental Data Resources, Inc.'s (EDR) City Directory Abstract is a screening tool designed to assist environmental professionals in evaluating potential liability on a target property resulting from past activities. EDR's City Directory Abstract includes a search and abstract of available city directory data. For each address, the directory lists the name of the corresponding occupant at five year intervals.

### RESEARCH SUMMARY

The following research sources were consulted in the preparation of this report. An "X" indicates where information was identified in the source and provided in this report.

<u>Year</u>	<u>Source</u>	<u>TP</u>	<u>Adjoining</u>	<u>Text Abstract</u>	<u>Source Image</u>
2010	Polk's City Director	-	X	X	-
2005	Polk's City Director	-	X	X	-
2001	Polk's City Director	-	X	X	-
1997	Polk's City Director	-	X	X	-
1990	Polk's City Director	-	X	X	-
1986	Polk's City Director	-	X	X	-
1981	Polk's City Director	-	X	X	-
1976	Polk's City Director	-	X	X	-
1972	Polk's City Director	-	X	X	-
1968	Con Survey City Directory	-	X	X	-
1962	Con Survey City Directory	-	X	X	-

## FINDINGS

### TARGET PROPERTY INFORMATION

#### ADDRESS

2900 West Beach Blvd  
Gulfport, MS 39501

#### FINDINGS DETAIL

Target Property research detail.

No Addresses Found

## FINDINGS

### ADJOINING PROPERTY DETAIL

The following Adjoining Property addresses were researched for this report. Detailed findings are provided for each address.

#### Beach Blvd

##### Beach Blvd

<u>Year</u>	<u>Uses</u>	<u>Source</u>
2010	No other address listings 2505-3206 range West Beach Blvd	Polk's City Director
2005	No other address listings 2505-3206 range West Beach Blvd	Polk's City Director
2001	No other address listings 2600-3206 range West Beach Blvd	Polk's City Director
1997	No other address listings 2668-3206 range West Beach Blvd	Polk's City Director
1990	No other address listings 2605-3206 range West Beach Blvd	Polk's City Director
1986	No other address listings 2605-3206 range West Beach Blvd	Polk's City Director
1981	No other address listings 2605-3206 range West Beach Blvd	Polk's City Director
1972	No other address listings 2605-3206 range West Beach Blvd	Polk's City Director
1968	No other address listings 2605-3206 range West Beach Blvd	Con Survey City Directory
1962	No other address listings 2605-3206 range West Beach Blvd	Con Survey City Directory

#### 2808 Beach Blvd

<u>Year</u>	<u>Uses</u>	<u>Source</u>
1990	Vacant	Polk's City Director
1986	Vacant	Polk's City Director
1981	Vacant	Polk's City Director
1976	Walter Jim Homes Inc	Polk's City Director
1972	Walter Jim Homes Inc	Polk's City Director
1968	Jim Walter Corp	Con Survey City Directory

#### 2818 Beach Blvd

<u>Year</u>	<u>Uses</u>	<u>Source</u>
1990	Sears Service Center	Polk's City Director
1981	Sears Automotive Service	Polk's City Director
1976	Sears Automotive Service	Polk's City Director

## FINDINGS

<u>Year</u>	<u>Uses</u>	<u>Source</u>
1972	Sears Automotive Service	Polk's City Director
1968	Sears Super Serv Station	Con Survey City Directory
1962	Sears Super Serv Station	Con Survey City Directory

### 2901 Beach Blvd

<u>Year</u>	<u>Uses</u>	<u>Source</u>
1997	Residential	Polk's City Director

### 2922 Beach Blvd

<u>Year</u>	<u>Uses</u>	<u>Source</u>
2005	Best Western Inn	Polk's City Director
2001	Best Western Inn	Polk's City Director
1997	Best Western Inn	Polk's City Director
1990	Best Western-Beach View Inn	Polk's City Director
1986	Best Western-Gulfport Inn	Polk's City Director
	Steak Place Restaurant	Polk's City Director
1981	Best Western-Gulfport Inn	Polk's City Director
1976	Best Western	Polk's City Director
1972	Downtown Motor Inn	Polk's City Director

### 2992 Beach Blvd

<u>Year</u>	<u>Uses</u>	<u>Source</u>
2010	Mississippi Power Co	Polk's City Director
	Powerco Federal Credit Union	Polk's City Director
2005	Mississippi Power Co	Polk's City Director
2001	Mississippi Power Company	Polk's City Director
	The Southern Company	Polk's City Director
1990	Mississippi Power Co (genl ofc)	Polk's City Director
1986	Mississippi Power Co (genl ofc)	Polk's City Director
1981	Mississippi Power Co (genl ofc)	Polk's City Director
1976	Mississippi Power Co (genl ofc)	Polk's City Director
1972	Mississippi Power Co (genl ofc)	Polk's City Director

### 3002 Beach Blvd

<u>Year</u>	<u>Uses</u>	<u>Source</u>
1990	Vacant	Polk's City Director
1986	Superior Chrysler Plymouth Inc	Polk's City Director
1981	Bohn Clay Chrysler Inc	Polk's City Director
1976	Gulfside Chrysler Center Inc	Polk's City Director
	Gulfside Chrysler Center Used Cars	Polk's City Director

## FINDINGS

<u>Year</u>	<u>Uses</u>	<u>Source</u>
1972	John Gimma Chrysler	Polk's City Director
	John Gimma P Sports Cars	Polk's City Director
1968	John Gimma Chrysler	Con Survey City Directory
1962	John Gimma Chrysler	Con Survey City Directory

### 3016 Beach Blvd

<u>Year</u>	<u>Uses</u>	<u>Source</u>
1968	West Beach Shell Service	Con Survey City Directory
1962	West Beach Shell Service	Con Survey City Directory

### 3028 Beach Blvd

<u>Year</u>	<u>Uses</u>	<u>Source</u>
1968	Vacant	Con Survey City Directory
1962	Residential	Con Survey City Directory

### 3028 1/2 Beach Blvd

<u>Year</u>	<u>Uses</u>	<u>Source</u>
1968	Residential	Con Survey City Directory
1962	Residential	Con Survey City Directory

### 3100 Beach Blvd

<u>Year</u>	<u>Uses</u>	<u>Source</u>
1997	St Peter's By-The-Sea Epscpl	Polk's City Director
1990	St Peter's By-The-Sea Episcopal Church	Polk's City Director
1986	St Peter's By-The-Sea Episcopal Church	Polk's City Director
1981	St Peter's By-The-Sea Episcopal Church	Polk's City Director
1976	Saint Peter's By-The-Sea Episcopal Church	Polk's City Director
1972	Saint Peter's By-The-Sea Episcopal Church	Polk's City Director
1968	Saint Peter's By-The-Sea Episcopal Church	Con Survey City Directory
1962	Saint Peter's By-The-Sea Episcopal Church	Con Survey City Directory

### 3110 Beach Blvd

<u>Year</u>	<u>Uses</u>	<u>Source</u>
1997	Residential	Polk's City Director
1990	Vacant	Polk's City Director
1986	King's Daughters Manor Apartments	Polk's City Director
1981	Harbour Square Apartments	Polk's City Director
1976	Menendez & Ditcharo Co Inc	Polk's City Director

## FINDINGS

<u>Year</u>	<u>Uses</u>	<u>Source</u>
1972	Menendez & Ditcharo Co Inc	Polk's City Director

### 3111 Beach Blvd

<u>Year</u>	<u>Uses</u>	<u>Source</u>
1976	Price's Beauty Shoppe	Polk's City Director
1972	Gulf Aire Apartments	Polk's City Director

### 3120 Beach Blvd

<u>Year</u>	<u>Uses</u>	<u>Source</u>
1997	Sawyer Real Estate	Polk's City Director
1990	Agency Rent A Car	Polk's City Director
	Sawyer Building	Polk's City Director
	Sawyer Real Estate Inc	Polk's City Director
1986	I T T Financial Services	Polk's City Director
	Sawyer Building	Polk's City Director
	Sawyer Real Estate Inc	Polk's City Director
1981	Aetna Finance Company	Polk's City Director
	Sawyer Building	Polk's City Director
	Sawyer Real Estate & Insurance	Polk's City Director
1968	Gulf Aire Apartments	Con Survey City Directory
1962	Gulf Aire Apartments	Con Survey City Directory

### 3124 Beach Blvd

<u>Year</u>	<u>Uses</u>	<u>Source</u>
1981	Vacant	Polk's City Director
1976	Beachview Texaco Self Service Station (gas station)	Polk's City Director
1972	Beachview Texaco Self Service Station (gas station)	Polk's City Director
1968	Jim & Jim Texaco Service	Con Survey City Directory
1962	Webb Kent Texaco Station	Con Survey City Directory

## FINDINGS

### TARGET PROPERTY: ADDRESS NOT IDENTIFIED IN RESEARCH SOURCE

The following Target Property addresses were researched for this report, and the addresses were not identified in the research source.

#### Address Researched

2900 West Beach Blvd

#### Address Not Identified in Research Source

2010, 2005, 2001, 1997, 1990, 1986, 1981, 1976, 1972, 1968, 1962

### ADJOINING PROPERTY: ADDRESSES NOT IDENTIFIED IN RESEARCH SOURCE

The following Adjoining Property addresses were researched for this report, and the addresses were not identified in research source.

#### Address Researched

Beach Blvd

2808 Beach Blvd

2818 Beach Blvd

2901 Beach Blvd

2922 Beach Blvd

2992 Beach Blvd

3002 Beach Blvd

3016 Beach Blvd

3028 1/2 Beach Blvd

3028 Beach Blvd

3100 Beach Blvd

3110 Beach Blvd

3111 Beach Blvd

3120 Beach Blvd

3124 Beach Blvd

#### Address Not Identified in Research Source

No Years Found

1962

1986

1990, 1986, 1981, 1976, 1972, 1968, 1962

1968, 1962

1997, 1968, 1962

No Years Found

No Years Found

No Years Found

No Years Found

No Years Found

1968, 1962

1968, 1962

1976, 1972

No Years Found

## **Appendix G**

### **Benthic Habitat Assessment**





Job No. 100018536

**BENTHIC HABITAT ASSESSMENT FOR THE PROPOSED  
PORT OF GULFPORT EXPANSION PROJECT  
HARRISON COUNTY  
GULFPORT, MISSISSIPPI**

U.S. Army Corps of Engineers  
Mobile District  
109 Saint Joseph Street  
Mobile, Alabama 36602

Prepared by:

Atkins  
6504 Bridge Point Parkway, Suite 200  
Austin, Texas 78730

October 2015



# Contents

---

	Page
List of Figures .....	iv
List of Tables .....	iv
Acronyms and Abbreviations .....	v
<b>1.0 INTRODUCTION .....</b>	<b>1-1</b>
1.1 GULF STURGEON .....	1-2
<b>2.0 METHODS .....</b>	<b>2-1</b>
2.1 HABITAT SURVEY .....	2-1
2.1.1 Field Methods .....	2-1
2.1.2 Data Analyses .....	2-1
2.2 SEDIMENT, WATER, AND ELUTRIATE SURVEY .....	2-3
2.2.1 Dioxins and Furans Analyses .....	2-5
2.2.2 Sample Preservation and Storage .....	2-5
2.2.3 Chain of Custody .....	2-5
2.2.4 Chemical Analyses .....	2-5
2.3 WATER QUALITY .....	2-5
<b>3.0 RESULTS .....</b>	<b>3-1</b>
3.1 HABITAT SURVEY .....	3-1
3.1.1 Macrobenthic Organisms .....	3-1
3.1.2 Seagrass .....	3-6
3.1.3 Grain Size .....	3-6
3.2 SEDIMENT, WATER, AND ELUTRIATE SURVEY .....	3-7
3.2.1 Dioxins and Furans Analyses .....	3-8
3.3 WATER QUALITY .....	3-8
<b>4.0 DISCUSSION .....</b>	<b>4-1</b>
4.1 HABITAT SURVEY .....	4-1
4.1.1 Seagrass .....	4-2
4.1.2 Grain Size .....	4-2
4.2 SEDIMENT, WATER, AND ELUTRIATE .....	4-3
4.3 WATER SURVEY .....	4-4
<b>5.0 CONCLUSIONS .....</b>	<b>5-1</b>
<b>6.0 REFERENCES .....</b>	<b>6-1</b>

**Appendixes:**

- A Maps
- B Scope of Work
  - Attachment A: Figure 1
  - Attachment B: Figures 2 and 3
  - Attachment C: Detection Limits
- C Benthic Data
- D Water and Sediment Chemistry Data
- E Water Quality Data

**Figures**

		<b>Page</b>
1	Relative Species Richness Found in the Project Footprint, Project Area, and Study Area of the Proposed Gulfport Expansion Project in Gulfport, Mississippi .....	3-4
2	Average Relative Species Abundance Within the Project Footprint, Project Area, and Study Area of the Proposed Gulfport Expansion Project in Gulfport, Mississippi .....	3-5

**Tables**

1	Gulf Sturgeon Habitat Characteristics .....	1-4
2	Sampling Nomenclature, Matrix, and Location for Sediment, Water, and Elutriate Samples Collected Within the Proposed Project Area, Gulfport, Mississippi .....	2-4
3	Percent Relative Abundance of Macrobenthic Organisms Collected from the Proposed Port of Gulfport Expansion Project Footprint, Project Area, and Study Area, Gulfport, Mississippi .....	3-2
4	Percent Occurrence of Macrobenthic Organisms Collected from the Proposed Port of Gulfport Expansion Project Footprint, Project Area, and Study Area, Gulfport, Mississippi .....	3-3
5	Species Diversity, Species Evenness, and Species Richness for the Proposed Port of Gulfport Expansion Project, Gulfport, Mississippi .....	3-6
6	Grain Size Percent and Substratum of the Proposed Port of Gulfport Expansion Project, Gulfport, Mississippi .....	3-7
7	Comparison of Water Quality Data Observed During this Habitat Survey .....	3-9
8	Percent Relative Abundance of Species that Overlap with Ross et al. (2009) .....	4-2
9	Percent Occurrence of Species that Overlap with Ross et al. (2009) .....	4-3
10	Grain Size and Substratum from Port of Gulfport Expansion Project Compared to Ross et al. (2009) .....	4-3
11	Water Quality Parameters from the Proposed Port of Gulfport Expansion Project, Gulfport, Mississippi .....	4-4
12	Habitat Characteristics of Gulf Sturgeon Observed at Each Sampling Location .....	5-2

## Acronyms and Abbreviations

---

°C	degrees Celsius
CMC	Criteria Maximum Concentration
DO	dissolved oxygen
EFH	Essential Fish Habitat
EIS	Environmental Impact Statement
EPA	U.S. Environmental Protection Agency
ERDC	Energy Research and Development Center
ERL	Effects Range Low
ERM	Effects Range Medium
FNC	Federal Navigation Channel
GPS	Global Positioning System
Gulf	Gulf of Mexico
H'	Shannon-Wiener Index
LPIL	lowest practical identifiable level
MDEQ	Mississippi Department of Environmental Quality
mg/L	milligrams per liter
MsCIIP	Mississippi Coastal Improvement Project
NMFS	National Marine Fisheries Service
NOAA	National Oceanic and Atmospheric Administration
PAH	polycyclic aromatic hydrocarbon
PE	East Pier expansion
PGEP	Port of Gulfport Expansion Project
pg/g	picograms/gram
PM	West Pier expansion
PN	North Harbor fill
psu	practical salinity unit(s)
SOW	Scope of Work
TB	turning basin
TEQ	toxic equivalent
USACE	U.S. Army Corps of Engineers
USFWS	U.S. Fish and Wildlife Service
USM-GCRL	University of Southern Mississippi Gulf Coast Research Laboratory
WHO	World Health Organization
WQC	water quality criteria
WQS	water quality standards

This page intentionally left blank.

## 1.0 INTRODUCTION

---

An Environmental Impact Statement (EIS) has been prepared to analyze and disclose the potential impacts of the proposed Port of Gulfport Expansion Project (PGEP) located in Gulfport, Mississippi (Appendix A, Figure 1). The proposed action is the expansion of the Port of Gulfport (Port) in Harrison County, Mississippi. The proposed PGEP involves the dredging and filling of approximately 282 acres of estuarine mud and sand bottom habitat in Mississippi Sound for construction of wharfs, bulkheads, terminal facilities, container storage areas, intermodal container transfer facilities, expanded turning basin, and construction of a breakwater in addition to placement of new work and maintenance dredged material (Appendix A, Figure 1).

During pre-application coordination with state and Federal agencies, Stephania Bolden, Ph.D., of the National Marine Fisheries Service (NMFS) Southeast Regional Office, Protected Resources Division, provided a list of comments to the U.S. Army Corps of Engineers (USACE) Mobile District via e-mail in April 2010. The comments indicated concern for potential Project-related impacts to Gulf sturgeon (*Acipenser oxyrinchus desotoi*). Additionally, during the scoping and public meetings, various agency personnel from NMFS responded with comments regarding the presence of Gulf sturgeon in the vicinity of proposed Project expansion activities and the inability to adequately determine potential impacts to Gulf Sturgeon from the expansion with the current data set. They also responded with comments regarding the need to adequately disclose contaminants in the dredging footprint and the potential impacts from dredging on aquatic organisms.

As a result of these comments, the USACE and Atkins, the Applicant's third-party EIS consultant, engaged in a discussion with the agencies to determine what information would be necessary to adequately estimate impacts to Gulf sturgeon, habitat (including Critical Habitat), prey species, and other aquatic organisms, including fisheries species. A consensus was reached that a habitat assessment of the proposed Project footprint, Project area, and study area would be necessary to address these concerns (see Appendix B).

The objectives of this Habitat Assessment are to:

1. Characterize the benthic habitat and community including substrate, seagrasses, macrobenthic organisms, and ambient water conditions within the Project footprint, Project area, and study area.
2. Compare similarities and differences in the benthic community between the Project footprint, Project area, and study area.
3. Compare benthic habitat and community in the Project footprint, Project area, and study area to areas where Gulf sturgeon are known to occur in the Mississippi Sound per Ross et al. (2009).
4. Describe the chemical parameters detected in the sediment, water, and elutriate samples collected within the Project footprint.



The data collected in this assessment will be used in the EIS to describe potential adverse impacts from proposed dredging operations and construction of proposed PGEP facilities on Gulf sturgeon, Essential Fish Habitat (EFH), EFH-designated species, and fisheries species.

## **1.1 GULF STURGEON**

Gulf sturgeon is a federally listed species with designated critical habitat and is a state-listed critically imperiled species in all three coastal counties of Mississippi, including Harrison County. Gulf sturgeon is an anadromous species, which means it breeds in freshwater after migrating up rivers from marine and estuarine environments. Since 1997, several research studies have posed hypotheses to better understand the freshwater and marine habitat requirements of the Gulf sturgeon, the genetic relationship of Gulf sturgeon throughout their distribution in the Gulf of Mexico (Gulf), their reproduction, and population size (Ross et al., 2003, 2009; Heise et al., 2005, 2009; Heise et al., 2004; Dugo et al., 2004). This research is ongoing and has more urgency and new questions since hurricanes Ivan (2004) and Katrina (2005) made landfall, because it is unknown what impact, if any, the hurricanes had on the population as a whole.

Historically, Gulf sturgeon occurred in rivers from the Mississippi River to the Tampa Bay, and in bays and estuaries from Florida to Louisiana, including the Pearl River and Pascagoula River (U.S. Fish and Wildlife Service [USFWS] et al., 1995). Gulf sturgeon have been documented to inhabit coastal rivers from Louisiana to Florida during the warmer months and overwinter in estuaries, bays, and the Gulf. In Florida, Gulf sturgeon have been documented to spend summer months near the mouth of springs and cool water rivers in the Suwannee River (USFWS et al., 1995). Fox et al. (2002) found that Gulf sturgeon occupied the shoreline areas of Choctawhatchee Bay, Florida, in 7 to 10 feet waters over sand substrate.

Immature and mature Gulf sturgeon participate in freshwater migration. Studies have shown that subadults and adults spend 8 to 9 months each year in rivers and 3 to 4 of the coolest months in the estuaries or Gulf waters (USFWS et al., 1995).

Gulf sturgeon are found in rivers, bays, and estuaries along the Mississippi Gulf coast. Ross et al. (2009) and Heise et al. (2004) conducted an extensive tagging and tracking study from 1997 to 2004, where they followed individual Gulf sturgeon throughout the Pascagoula and Pearl rivers, Mississippi Sound, and in Breton Sound. In Mississippi Sound, the majority of the tracking effort was near the barrier islands and concentrated in the central and eastern portion of Mississippi Sound. Gulf sturgeon from both the Pearl and Pascagoula rivers are known to use the Mississippi Gulf Coast, including the barrier islands, for migration and foraging. Rogillio et al. (2007) and Ross et al. (2009) located tagged adult Gulf sturgeon among Cat, Ship, Horn, and Petit Bois islands from October through March.

The USACE Engineer Research and Development Center (ERDC) is conducting an ongoing Gulf sturgeon monitoring effort at Ship Island in association with the Mississippi Coastal Improvements Program (MsCIP). The study's objective is to define the seasonal occurrences and movements of Gulf

sturgeon around Ship Island and within Camille Cut. This research has shown that between September 2011 and June 2012, a total of 13,720 detections from approximately 14 Gulf sturgeons originating from five rivers (Pearl, Pascagoula, Escambia, Blackwater, and Yellow) were found in their study area (ERDC, 2012).

Comparatively, between September 2012 and June 2013, ERDC logged 94,244 detections from 21 Gulf sturgeon originating from the Pearl, Pascagoula, Escambia, Blackwater, Yellow, Choctawhatchee, and Brothers Rivers. The greatest number of Gulf sturgeon detected during the 2011-2012 sampling period occurred in November and December followed by decreasing monthly numbers from January through March. Whereas, the greatest number of fish documented during the 2012-2013 sampling period occurred in December with similar numbers through March. They noted a significant decrease in Gulf Sturgeon activity in the array in April, while the greatest number of detections was recorded in December and January. The fewest number of detections per month were reported for October and April (ERDC, 2013). The summary for the 2014 deployment period had not yet been submitted to the USACE.

Gulf sturgeon monitoring from fall 2012 to 2014 was conducted in the Mississippi Sound, between West and East Ship Islands, and around the Project area (Peterson et al., 2015, Appendix O of the EIS). The Gulf sturgeon monitoring study was conducted using a network of telemetry receivers in the vicinity of the proposed Project area (referred to as the Gulfport array in the study) and further east (east gate) and west (west gate) between the Port and the Pascagoula and Pearl Rivers, respectively, to determine the use of near shore and the Project area by Gulf sturgeon (Peterson et al., 2015, Appendix O of the EIS). Key results from this study are summarized below.

- Adult Gulf sturgeon are mainly from the Pascagoula and Pearl drainages but there were some eastern population fish [Escambia, Choctawhatchee and Blackwater (recaptured fish) drainages] that appeared in the Gulfport array.
- Overall, Gulf sturgeon occurrence appears to be more concentrated on the east gate and eastern portion of the Gulfport array compared to the west gate and western portion of the array.
- Total detections were markedly lower in the year 2 data set than year 1, with four individuals (two from each drainage) returning to the array over the 2 years of this project. These data suggest some level of consistent and repeatable regional-scale movement patterns in Gulf sturgeon from the western Gulf drainages.
- The number of detections per fish and time within the array varied greatly among all the detected Gulf sturgeon, with individuals taking both transitory paths through the Gulfport array, and localized movements within the entire array.
- Gulf sturgeon from each life stage category (adult, sub-adult, juvenile) were detected. The adults, unexpectedly, had the greatest number of occurrences and detections. Juveniles and sub-adults life history stages may experience restricted movements away from natal rivers as young fish, and only begin to expand their range later with age, based on the relative low occurrence of detections of those two life history stages. However, adults have been documented within the proposed Project area during pre- and post-migratory periods. The data suggest that the Gulf sturgeon

habitat monitored serves as a corridor between other habitat types, drainages, feeding zones, or is used as a pre-/post-migratory acclimation zone.

Gulf sturgeon spend their time feeding and searching for food while they overwinter in the Mississippi Sound and fast while in a freshwater environment, which makes them totally dependent on the marine/estuarine food web for growth (Gu et al., 2001). Heard et al. (2002) examined the stomach contents of one Gulf sturgeon that was found dead in Mississippi, and the Florida lancelet (*Branchiostoma floridae*) was the sole organism that was identified. Later studies, as well as studies conducted in other parts of the Gulf, confirm that Florida lancelets are one of the key prey items of Gulf sturgeon (USFWS and National Oceanic and Atmospheric Administration [NOAA], 2009). However, Gulf sturgeon also eat various types of polychaetes (segmented worms), mollusks (including sand dollars [*Mellita quinquesperforata*] and other bivalve shells), and other arthropods (USFWS and NOAA, 2009).

The habitat where most subadult and adult Gulf sturgeon were located in the Mississippi Sound is shown in Table 1. Gulf sturgeon winter habitat is characterized by relatively shallow (less than 23 feet), well oxygenated and clear water located over sand and shell fragment substrate (Ross et al., 2009). Habitats are also characterized by abundant food items, including lancelets, sand dollars, haustoriid amphipods (bottom dwelling crustaceans), bivalve shells, and various types of polychaetes.

Table 1  
Gulf Sturgeon Habitat Characteristics

Characteristic	Average	Minimum	Maximum
Dissolved oxygen (mg/L*)	7.5	4.7	9.2
Water Depth (feet)	12.8	3.9	22.9
Bottom temperature (°C)	15.6	11.5	21.5
Salinity (psu**)	22.8	0	33.7
Dominant substrate	Mixture of fine to medium sized sand	Mud and clay	Medium to coarse sand
Sub-dominant substrate	Medium to coarse sand	Mud and clay	Shell fragments

Source: Ross et al. (2009)

\*mg/L = milligrams per liter

\*\*psu = practical salinity unit(s)

According to the Gulf sturgeon 5-year review (USFWS and NOAA, 2009), the most aggressive threats to the Gulf sturgeon population include channel improvements and maintenance dredging activities, poor water quality associated with contamination by pesticides/heavy metals/industrial contaminants, red tide, climate change, and impeding river flow via dams or diversions.

## **2.0 METHODS**

---

### **2.1 HABITAT SURVEY**

#### **2.1.1 Field Methods**

On April 3 and 5, 2012, substrate was collected using a Petite Ponar dredge from 48 sample locations within the Project footprint, Project area, and study area of the proposed PGEP (Appendix A, Figures 2 and 3). Petite Ponar dredge grabs were collected at each sample location. A composite sample of approximately 1 liter of material was obtained at each sample location (three to ten Petit Ponar grabs per location). Each benthic sample was field-washed through a 541-micron mesh wash bucket (WildCo®). Each benthos sample was preserved in 10 percent formalin and stored in a 9-x-12-inch, 4-milliliter resealable plastic bag labeled with the date and sample location identification number.

Benthos samples were identified in a laboratory using a dissecting microscope to the lowest practical identifiable level (LPIL) and enumerated. The references (keys) used to identify taxa included *Shells and Shores of Texas* (Andrews, 1977), *Guide to the Identification of Marine and Estuarine Invertebrates* (Gosner, 1971), *The Polychaete Worms, Definitions and Keys to the Orders, Families and Genera* (Fauchald, 1977), and *Macrobenthic Inventory of the Aquatic Shoreline Habitat Within the Gulf Islands National Seashore* (Rakocinski et al., 1995). Michael A. Poirrier, PhD., an emeritus professor at The University of New Orleans aided in identifying a portion of the macrobenthic organisms. Benthic macroinvertebrate data are presented in Appendix C.

A visual characterization score of the dominant substrata (substrate) was recorded as 1-clay, mud; 2-fine sand; 3-medium to coarse sand; and 4-shell fragments (Ross et al., 2009). Additionally, grain size was analyzed for each of the sampling locations to determine the percent composition of sediment type throughout the Project footprint, Project area, and study area.

Water quality conditions were measured using similar methods as Ross et al. (2009) and are detailed in Section 2.3 (Water Quality).

#### **2.1.2 Data Analyses**

Several metrics were identified for comparing the benthic community in the Project footprint, Project area, and study area. These included:

- Percent relative abundance
- Percent occurrence
- Relative species richness and species richness
- Average relative species abundance

- Shannon-Wiener Diversity Index
- Species evenness

Relative abundance refers to how numerous a taxon is relative to other taxon in a defined location or community (Brower et al., 1998). Relative abundance was calculated for all the samples, and separately for the Project footprint, Project area, and study area, by taking the number of individuals collected in a particular species divided by the total number of organisms collected in a particular group. This was calculated to determine which species were the most abundant species collected and if any similarities occurred between the survey and Ross et al. (2009).

Percent occurrence is the number of samples containing a taxon compared to the number of samples taken in a particular area (Brower et al., 1998). It was calculated for all samples, and individually for samples in the Project footprint, Project area, and study area. Percent occurrence was calculated by dividing the number of times a taxa was collected by the number of samples collected in a particular area (Project footprint, Project area, or study area). This was calculated to determine whether or not a taxa was widely distributed.

Species richness is the number of species collected in a particular area (Brower et al., 1998). Cumulative species richness was calculated for all samples and separately for samples in the Project footprint, Project area, and study area.

Average relative abundance refers to the mean number of individuals collected in a particular area. This was calculated by adding the individual species' relative abundance from each of the three sample areas and then dividing by three. The cumulative relative abundance was calculated by adding the number of each species in all three sampling areas and dividing it by the total number of species collected.

The Shannon-Wiener index takes into account both species richness and relative abundance of each species to quantify how well species are represented within a community. The Shannon-Wiener index was calculated to measure the diversity of the Project footprint, Project area, and study area using the following equation:  $H' = - \sum p_i \ln p_i$ ; where  $H'$  = the Shannon-Wiener index, and  $p_i$  = the proportional abundance of each taxon (Brower et al., 1998). The index value ranges from 0 to about 4.5 with low numbers representing less diverse communities and high numbers representing more diverse communities. In general, it is thought that more disturbed and less stable environments should have a lower index value.

Species evenness is used to measure the evenness in the distribution of organisms across all species present in a community. Evenness was calculated using  $E_{var}$ .  $E_{var}$  is based on the variance in abundance (Keeney et al., 2007). The index ranges from 0 to 1, with increasing values indicating an increasingly even distribution. Low values are representative of communities dominated by one to a few taxa; whereas, high numbers are representative of communities with many taxa with similar abundance.

## 2.2 SEDIMENT, WATER, AND ELUTRIATE SURVEY

Sediment, water, and elutriate sampling was only performed in the proposed Project footprint and was conducted simultaneously with the benthic sampling. Field sampling procedures and laboratory analyses were conducted according to the same methodology used by the USACE for routine sediment, water, and elutriate analysis prior to maintenance dredging (Environmental Protection Agency [EPA]/USACE, 1998). Additionally, all sample collections and chemical analyses were conducted according to the Mississippi Department of Environmental Quality (MDEQ) State of Mississippi Water Quality Criteria for Intrastate, Interstate, and Coastal Waters (MDEQ, 2007). Prior to sample collection, all containers and sampling equipment were cleaned according to protocols described in Plumb (1981). Care was taken to avoid contamination to sampling devices from the boat deck or other surfaces. Powderless latex gloves were worn during sample collection.

Samples in Gulfport Harbor were taken from four areas within the proposed Project footprint, including the Turning Basin Expansion, the West Pier Expansion, the East Pier Expansion, and the North Harbor Expansion areas (Appendix A, Figure 4). All sample locations were located and documented using a hand-held Garmin 76 CS Global Positioning System (GPS) accurate to <16.4 feet. Coordinates for all locations are included in Table 2. Sediment samples (surface grab samples) were collected at each of the four Project footprint areas, approximately every 500–1,000 linear feet, depending on the area.

Samples were collected so that three subsamples (PE-11-A,B,C) were composited into one sample within the East Pier Expansion; two subsamples (PN-11-A,B) were composited into one sample within the North Harbor Expansion; nine subsamples (PM-11-A through PM-11-I) were composited into three samples within the West Pier Expansion; and six subsamples (TB-11-A through TB-11-F) were composited into two samples for the Turning Basin Expansion (Table 2).

Sediment samples were collected using a Petit Ponar to grab surface sediment. Prior to collecting each sample, all residual sediment was removed from the Petit Ponar dredge with a brush. It was rinsed with deionized water and then with ambient water. Each sample was deposited into a clean polyethylene pan. Composite samples were mixed thoroughly and then placed into a pre-cleaned glass jar. The jar was filled completely to avoid headspace and ensure the total sample volume. The lid was tightly secured and placed into a cooler with ice.

**Table 2**  
**Sampling Nomenclature, Matrix, and Location for Sediment, Water, and Elutriate Samples**  
**Collected Within the Proposed Project Area, Gulfport, Mississippi**

Sample Number	GPS Location	Sample Matrix	Analyses
<b>Pier Expansion</b>			
PE-11-A	N30 21 19.3 W89 05 12.6	Sediment	W, S, E, GS
PE-11-B	N30 21 19.3 W89 05 07.8	Sediment, Water	Component of PE location above
PE-11-C	N30 21 14.4 W89 05 07.8	Sediment	Component of PE location above
PN-11-A	N30 21 34.0 W89 05 37.9	Sediment, Water	W, S, E, GS
PN-11-B	N30 21 38.8 W89 05 37.9	Sediment	Component of PN location above
PM-11-A	N30 20 59.5 W89 05 22.9	Sediment	W, S, E, GS
PM-11-B	N30 20 49.9 W89 05 32.7	Sediment, Water	Component of PM location above
PM-11-C	N30 20 49.7 W89 05 22.9	Sediment	Component of PM location above
PM-11-D	N30 20 39.9 W89 05 22.8	Sediment	W, S, E, GS
PM-11-E	N30 20 39.7 W89 05 13.1	Sediment, Water	Component of PM location above
PM-11-F	N30 20 39.6 W89 05 03.7	Sediment	Component of PM location above
PM-11-G	N30 20 30.2 W89 05 22.8	Sediment	W, S, E, GS
PM-11-H	N30 20 30.1 W89 05 12.9	Sediment, Water	Component of PM location above
PM-11-I	N30 20 30.3 W89 05 37.9	Sediment	Component of PM location above
<b>Basin Expansion</b>			
TB-11-A	N30 20 49.5 W89 05 03.1	Sediment	W, S, E, GS
TB-11-B	N30 20 49.7 W89 04 53.0	Sediment, Water	Component of BE location above
TB-11-C	N30 20 39.9 W89 04 53.4	Sediment	Component of BE location above
TB-11-D	N30 20 39.7 W89 04 43.2	Sediment	W, S, E, GS
TB-11-E	N30 20 29.8 W89 04 33.5	Sediment, Water	Component of BE location above
TB-11-F	N30 20 30.4 W89 04 44.6	Sediment	Component of BE location above

GPS Coordinate System WGS 84

PE = East Pier; PN = North Harber; PM – West Pier; TB = Turning Basin

W = Water; E = Elutriate; S = Sediment; GS = Grain Size

Water samples were collected one time using a suitable nonmetallic bilge pump with a foodgrade hose and a peristaltic pump. The depth of each water sample collected was at mid-depth. Prior to filling sample containers, the pump was allowed to run and purge water from the hose from any previous samples to ensure water collected was representative of the sample location. Water samples were then collected in polyethylene and glass bottles provided by the laboratory. Water samples to be analyzed for metals were collected using a variable-speed peristaltic pump and Teflon<sup>®</sup> tubing. Water samples to be analyzed for metals other than mercury and selenium were filtered through a clean 0.45- $\mu\text{m}$  filter prior to dispensing into containers. Pre-cleaned brown glass bottles were used for organic analyses. All bottles contained the appropriate preservatives and were filled completely to avoid headspace.

Elutriates for chemical analyses were prepared from sediment and water collected. Sediment and water was combined at a 1:4 ratio, respectively, and prepared as designated in EPA/USACE (1998) by laboratory personnel.

### **2.2.1 Dioxins and Furans Analyses**

All sediment samples were analyzed for dioxins and furans. Laboratory results were reported as toxic equivalents (TEQ). The laboratory used World Health Organization (WHO) 2005 toxic equivalency factors to calculate TEQ (WHO, 2005). The target detection limits for each individual congener were 0.1 picograms/gram (pg/g) dry weight for sediment. Higher detection limits may be acceptable if these detection limits could not be met.

### **2.2.2 Sample Preservation and Storage**

Collected samples were cooled and stored at 2 to 4 degrees Celsius ( $^{\circ}\text{C}$ ) until laboratory analysis. Analyses were performed within the recommended holding times, as described in EPA/USACE (1998).

### **2.2.3 Chain of Custody**

A chain of custody was completed and accompanied the samples until laboratory analysis.

### **2.2.4 Chemical Analyses**

Each composite sample was analyzed for water, sediment, and elutriate conditions. All chemical analyses were performed by Anacon, Inc, who is accredited for the analytes/analyte groups and matrices analyzed by the Texas Commission on Environmental Quality, an accrediting authority recognized by the National Environmental Laboratory Accreditation Program. The constituents for which analyses were conducted, the methods used, and the method detection limits are provided in Appendix D.

## **2.3 WATER QUALITY**

*In situ* standard water quality parameters were recorded at each sample site (n = 48) at the surface and 1 foot off the bottom at the time sediment, water, and benthic samples were collected. A YSI 6920 v2



Series multi-parameter instrument was used to measure water quality parameters, including: dissolved oxygen (DO) measured in milligrams per liter (mg/L), pH measured in standard units, salinity (psu), water temperature (°C), air temperature (°C), and water depth (feet). Turbidity was measured as water clarity using a Secchi disk in centimeters, but converted to inches to keep the units consistent. In addition to water quality parameters, ambient water and weather conditions were recorded. Multi-parameter water quality instrument calibrations were performed before and after sampling. Water quality data are presented in Appendix E.

## 3.0 RESULTS

---

### 3.1 HABITAT SURVEY

#### 3.1.1 Macrobenthic Organisms

Benthic samples were taken from 48 sample locations within the proposed Project footprint, Project area, and study area. The location of each site is shown in Appendix A, Figures 2-4. Samples yielded a total 105 different macrobenthic taxa identified to the LPIL (Appendix C). A study area location (SA 18) yielded the highest total number of individuals collected and the highest total number of taxa. A location in the East Pier Expansion Area (PE-11-B) yielded the lowest number of total individuals collected and taxa.

Tables 3 and 4 contain taxa that comprise  $\geq 1$  percent cumulative relative abundance and taxa that overlap with Ross et al. (2009). *Leitoscoloplos fragilis* (polychaete worm) had the highest cumulative and area-specific percent relative abundance with an average of 23.3 (Table 3). *L. fragilis* also exhibited the second highest frequency of occurrence in the Project footprint (90.0 percent) and tied for the highest in the Project area (88.9 percent), refer to Table 4. Nemertea (LPIL), ribbon worm, was collected and had a cumulative occurrence of 92 percent, but only accounted for 9 percent of the cumulative relative abundance. In contrast, *Mediomastus ambiseta*, a polychaete, showed the second highest relative abundance (14 percent), but had a low cumulative percent occurrence (27 percent) when compared to *L. fragilis* (85 percent), Nemertea (92 percent), and *Glycinde solitaria* (polychaete worm, 88 percent).

Species richness was calculated for the Project footprint, Project area, and study area, and compared to the total number of taxa found over the entire area sampled. The Project area and the Project footprint had similar relative species richness, 44.2 percent and 38.1 percent, respectively. The study area had much higher relative species richness than the Project footprint and Project area with 86.6 percent of the total taxa encountered. The North Harbor and Turning Basin areas within the existing Federal Navigation Channel (FNC) at the Port had a lower relative species richness than the West Pier and East Pier areas outside of the existing channel (Figure 1).

Table 3  
Percent Relative Abundance of Macrobenthic Organisms Collected from the Proposed Port of Gulfport Expansion Project Footprint, Project Area, and Study Area, Gulfport, Mississippi

Taxa	Percent Relative Abundance				
	Cumulative	Footprint	Project Area	Study Area	Average
<i>Leitoscoloplos fragilis</i> *	19	28.0	27.6	14.3	23.3
<i>Mediomastus ambiseta</i> *	14	11.8	1.1	17.6	10.2
Nemertea (LPIL)	9	7.8	16.4	8.2	10.8
<i>Glycinde solitaria</i>	8	7.6	13.6	7.5	9.6
<i>Sigambra tentaculata</i>	5	2.2	0.3	7.0	3.2
<i>Magelona</i> sp. (LPIL)	4	—	0.6	6.1	2.2
<i>Balanoglossus aurantiacus</i>	4	6.2	1.7	3.1	3.7
<i>Acteocina canaliculata</i>	3	9.2	1.1	1.5	3.9
<i>Cossura soyeri</i>	3	5.1	2.5	2.6	3.4
<i>Paraprionospio pinnata</i>	3	3.9	1.7	2.5	2.7
Actinaria (LPIL)	2	0.7	7.2	1.6	3.2
<i>Notomastus</i> sp. (LPIL)	2	—	—	2.4	0.8
<i>Macoma tenta</i>	2	—	—	2.3	0.8
<i>Capitella capitata</i>	1	1.2	5.0	0.4	2.2
Decapoda	1	0.4		1.4	0.6
<i>Oxyurostylis</i> sp. (LPIL)	1	0.4	2.2	1.0	1.2
Mysidaceae (LPIL)	1	0.3	1.1	1.2	0.9
<i>Pectinaria gouldii</i>	1	1.0	0.3	1.0	0.7
<i>Apocorophium louisianum</i>	1	—	—	1.3	0.4
<i>Spiophanes bombyx</i> *	1	—	—	1.3	0.4
<i>Streblospio benedicti</i>	1	2.4	—	0.4	0.9
Amphipoda (LPIL)	1	—	1.7	0.9	0.9
<i>Glycera americana</i>	1	0.4		1.0	0.5
Hesionidae	1	1.1	0.3	0.6	0.7
Oligochaeta (LPIL)	1	1.1	—	0.7	0.6
<i>Spiochaetopterus oculus</i>	1	1.0	0.8	0.6	0.8
Chaetognatha	1	0.3	3.6	0.3	1.4
<i>Tharyx acutus</i>	1	0.3		0.7	0.3
<i>Amphicteis floridus</i>	1	0.3	0.3	0.6	0.4
<i>Nassarius acutus</i> *	1	0.6	—	0.6	0.4
Bivalvia (LPIL)*	<0.1	—	—	0.2	0.1
<i>Mulinia lateralis</i> *	<0.1	0.4	—	—	0.1
<i>Prionospio cristata</i> *	<0.1	—	—	<0.1	<0.1

— Taxa was not recorded

\* Taxa identified in Ross et al. (2009)

Table 4  
Percent Occurrence of Macrobenthic Organisms Collected from the Proposed Port of Gulfport Expansion Project Footprint, Project Area, and Study Area, Gulfport, Mississippi

Taxa	Percent Occurrence				
	Cumulative	Footprint	Project Area	Study Area	Average
<i>Leitoscoloplos fragilis</i> *	85	90.0	88.9	78.9	85.9
<i>Mediomastus ambiseta</i> *	27	60.0	22.2	5.3	29.2
Nemertea (LPIL)	92	95.0	77.8	94.7	89.2
<i>Glycinde solitaria</i>	88	85.0	88.9	89.5	87.8
<i>Sigambra tentaculata</i>	46	30.0	11.1	78.9	40.0
<i>Magelona</i> (LPIL)	29	—	22.2	63.2	28.5
<i>Balanoglossus aurantiacus</i>	38	55.0	22.2	26.3	34.5
<i>Acteocina canaliculata</i>	50	55.0	44.4	47.4	48.9
<i>Cossura soyeri</i>	23	25.0	55.6	5.3	28.6
<i>Paraprionospio pinnata</i>	63	65.0	55.6	63.2	61.2
Actinaria (LPIL)	29	15.0	33.3	42.1	30.1
<i>Notomastus</i> (LPIL)	15	—	—	36.8	12.3
<i>Macoma tenta</i>	6	—	—	15.8	5.3
<i>Capitella capitata</i>	21	25.0	11.1	21.1	19.1
Decapoda	23	10.0	0.0	47.4	19.1
<i>Oxyurostylis</i> (LPIL)	29	10.0	33.3	47.4	30.2
Mysidaceae (LPIL)	21	10.0	11.1	36.8	19.3
<i>Pectinaria gouldii</i>	21	25.0	11.1	21.1	19.1
<i>Apocorophium louisianum</i>	4	—	—	10.5	3.5
<i>Spiophanes bombyx</i> *	6	—	—	15.8	5.3
<i>Streblospio benedicti</i>	10	15.0	—	10.5	8.5
Amphipoda (LPIL)	15	0.0	11.1	31.6	14.2
<i>Glycera americana</i>	15	15.0	<0.1	21.1	12.0
Hesionidae	21	20.0	11.1	26.3	19.1
Oligochaeta (LPIL)	8	10.0	0.0	10.5	6.8
<i>Spiochaetopterus oculatus</i>	35	25.0	33.3	47.4	35.2
Chaetognatha	13	5.0	11.1	21.1	12.4
<i>Tharyx acutus</i>	6	5.0	—	10.5	5.2
<i>Amphicteis floridus</i>	2	10.5	11.1	26.3	16.0
<i>Nassarius acutus</i> *	13	15.0	—	15.8	10.3
Bivalvia (LPIL)*	8	—	—	21.1	7.0
<i>Mulinia lateralis</i> *	6	15.0	—	—	5.0
<i>Prionospio cristata</i> *	2	—	—	5.3	1.8

— Taxa was not recorded

\* Taxa identified in Ross et al. (2009)

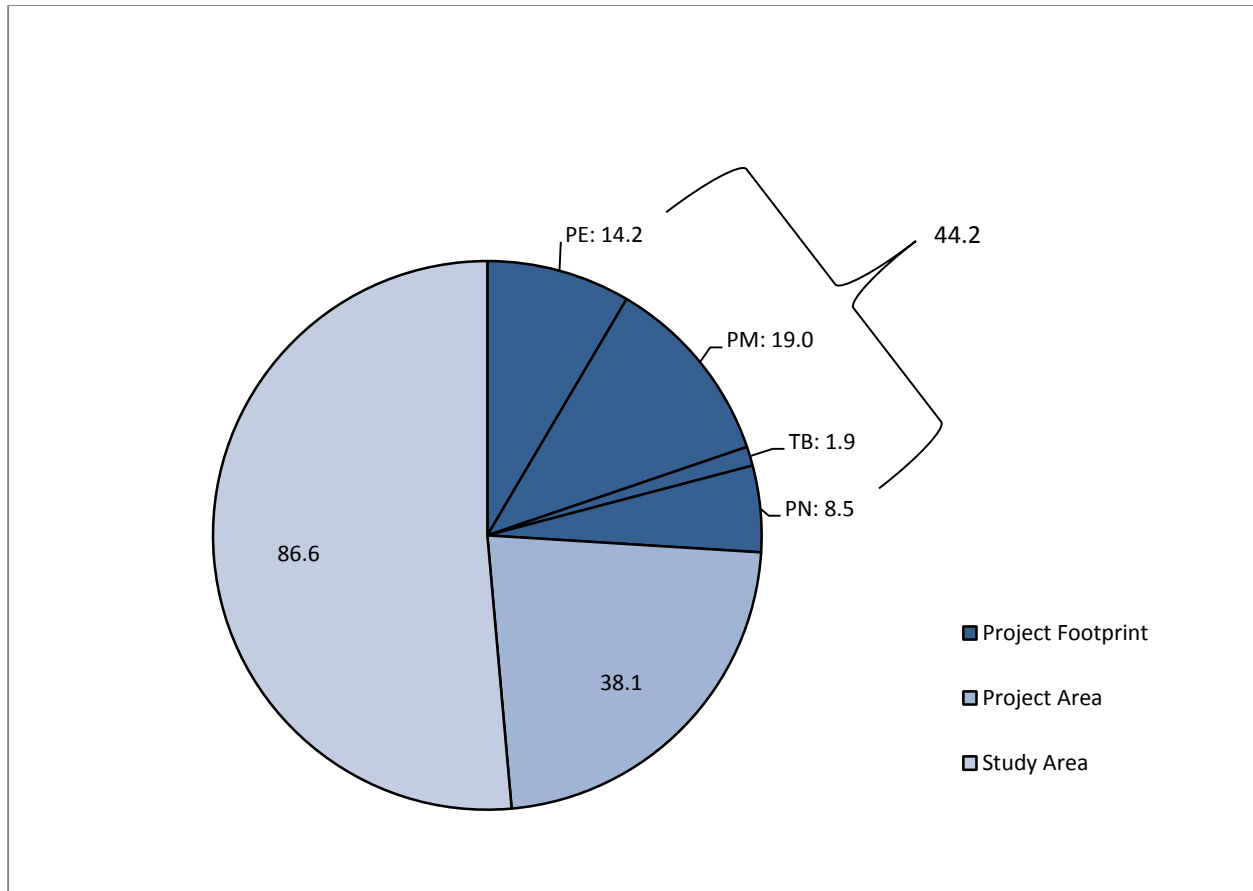

Figure 1  
 Relative Species Richness Found in the ProjectFootprint, Project Area, and Study Area of the Proposed Gulfport Expansion Project in Gulfport, Mississippi

Average species abundance showed the same trends as relative species richness with the Project footprint and the Project area having an overall lower abundance than the study area. The average number of species collected at each sample location was not only higher in the study area, but the number of species collected at each sample location varied more widely in the study area than in the Project footprint and Project area (Figure 2).

The median number of taxa collected in each group of samples (Project footprint, Project area, and study area) is shown on Figure 2, where the light blue and dark blue boxes meet in the middle. The median number of taxa collected within the Project footprint and the Project area were similar, with 9 taxa being collected in the Project footprint and 8.5 taxa in the Project area. A median of 15 taxa were collected in the study area.

The 25 and 75 percent quartile are shown as the lower and upper limits of the blue boxes in each group of samples. Both the Project footprint and the Project area had similar 25 and 75 percent quartile limits. The quartile limits for the Project footprint ranged from 8 to 10.25 taxa, while the Project area ranged from 7.75 to 10.75 taxa, and the study area ranged from 13 to 21.5 taxa.

The limits of the error bars are the minimum and the maximum number of taxa collected in each group of samples. The average relative abundance of taxa in the study area ranged from 8 to 36, as compared to the Project footprint which ranged from 4 to 16 taxa, and the Project area that had 7 to 15 taxa.

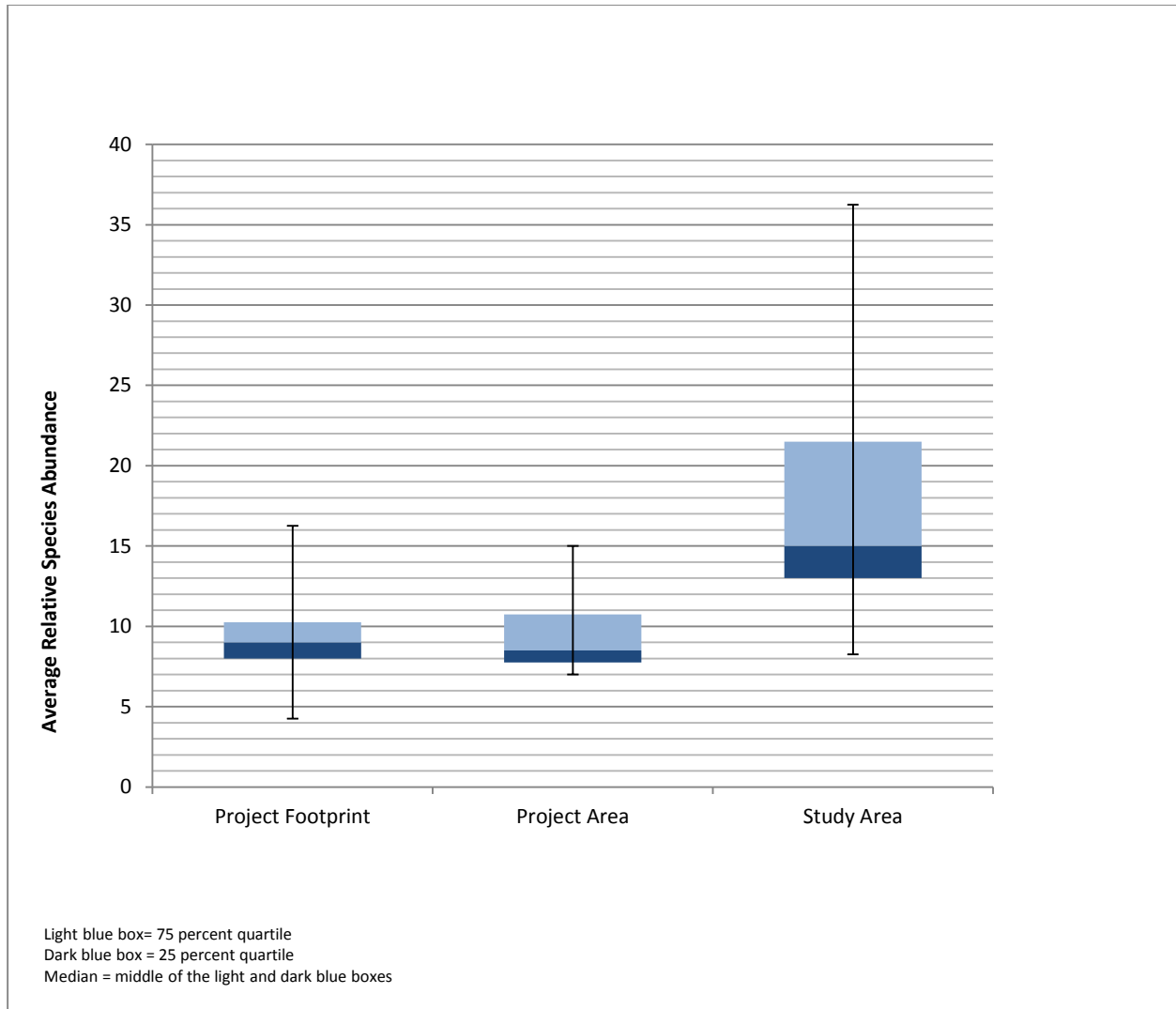

Figure 2  
 Average Relative Species Abundance within the Project Footprint, Project Area, and Study Area of the Proposed Gulfport Expansion Project in Gulfport, Mississippi

The Shannon-Wiener ( $H'$ ) diversity index, species evenness, and species richness were calculated for the Project footprint, Project area, and study area (Table 5). The cumulative values were computed and yielded a 3.16 Shannon-Wiener index and 0.88 in species evenness. The study area had the highest diversity as compared to the Project footprint and Project area, which were relatively similar (see Table 5). The study area also had the most species (highest species richness value) and was dominated by single occurrences of species (low evenness value). The Project area had the lowest diversity of species (2.60), but had the most even distribution of species (0.37) as compared to the study area and the

footprint. However, the distribution of species (species evenness) within the Project footprint, Project area, and study area were relatively similar. Twice as many species were collected in the study area when compared to the Project footprint and Project area.

Table 5  
Species Diversity, Species Evenness, and Species Richness for the  
Proposed Port of Gulfport Expansion Project, Gulfport, Mississippi

	Number of Samples	Shannon-Wiener Index	Species Evenness Index	Species Richness
Project Footprint	20	2.67	0.30	46
Project Area	9	2.60	0.37	40
Study Area	19	3.17	0.26	91
Cumulative	48	3.16	0.88	105

### 3.1.2 Seagrass

No seagrass was observed during the habitat survey.

### 3.1.3 Grain Size

Sediment was collected for grain size analyses from 48 sample locations, but only 47 samples were analyzed by Anacon, Inc., because one jar broke while transporting samples back to the lab. Sand was the most dominant sediment type and ranged from 31.4 to 68.7 percent, whereas clay ranged from 13.6 to 33.6 percent, and silt ranged from 16.4 to 33.1 percent (Table 6). Sample PA 5 from the Project area was the only location that had sediment that was fine, comprising 0.6 percent of the three sample areas. Sand dominated the North Harbor and West Pier sample areas within the Project footprint, whereas the East Pier and Turning Basin sample areas had sediment evenly divided between sand/clay/silt. Sand was also the dominant sediment type in both the Project area and study area (Appendix A, Figures 5-7).

The substratum ranged from 1 (clay/mud) to 2 (fine sand). No medium to coarse sand or shell fragments were observed during the field survey. The areas that contained sand via visual characterization were located in the North Harbor Expansion area within the Project footprint and the study area. This visual comparison varied from the grain size analysis with the visual characterization biased toward characterizing fine sand as mud.

Table 6  
Grain Size Percent and Substratum of the Proposed  
Port of Gulfport Expansion Project, Gulfport, Mississippi

		N	Mean % (95% Confidence Interval)				Substratum <sup>b</sup> Mean (95% Confidence Interval)
			Sand <sup>a</sup>	Clay <sup>a</sup>	Silt <sup>a</sup>	Fines <sup>a</sup>	
Project Footprint	PE	3	31.4 (0.3)	31.4 (0.2)	33.1 (0.2)	—	1.0
	PM	9	56.3 (0.7)	23.4 (0.4)	20.1 (0.3)	—	1.4 (<0.0)
	PN	2	68.7 (0.6)	13.6 (0.5)	16.4 (0.2)	—	2.0 (0.1)
	TB	6	36.4 (0.9)	33.6 (0.4)	26.7 (0.5)	—	1.0
Project Area		9	51.0 (0.6)	22.3 (0.3)	26.1 (0.3)	0.6 (0.0)	1.3 (<0.0)
Study Area		18	48.4 (0.5)	22.3 (0.3)	29.0 (0.3)	—	1.9 (<0.0)

a Anacon, Inc., Data

b Substratum coded as 1-clay, mud; 2-fine sand; 3-medium to coarse sand; 4-shell fragments

### 3.2 SEDIMENT, WATER, AND ELUTRIATE SURVEY

Sediment, water, and elutriate analyses were conducted for those locations within the proposed Project footprint. The water quality parameters taken at the time of collection are presented in Appendix E, as are the coordinates at which samples were collected. Included in Appendix D, Tables D2-D5 list the parameters and the concentrations of detected parameters in the various media. Also included in the tables are appropriate standards, criteria, or screening values to which the detected parameters can be compared.

The results of the chemical analyses for compounds detected in the water and elutriate samples are presented in Tables D3 and D4 in Appendix D. Also included in Tables D3 and D4 are the Mississippi Surface Water Quality Standards (WQS), provided by the MDEQ for the protection of aquatic life and the EPA water quality criteria (WQC). Since the sediment and water samples used to prepare the elutriates are from grab samples from a marine environment and thus are a snapshot in time, not from a series of samples taken over time as they are in various studies, such as the four-day chronic WQC (Criteria Continuous Concentration), the acute marine WQS and acute WQC (Criteria Maximum Concentration [CMC]) were used to determine water criteria. The ammonia CMCs are specific to each individual pH, temperature, and salinity, and the values given in Tables D3 and D4 are approximate for the range of values of these parameters in Appendix E. An examination of Table D3 indicates that there are no exceedances of any acute WQS or CMC for any of the sample locations.

Elutriates were prepared from collected sediment and station water, filtered to remove suspended material for trace metal analysis (except mercury and selenium) or centrifuged, and submitted for chemical analysis. Therefore, the elutriates provide information on those constituents that are dissolved into the water column during dredging, filling, or open-water placement. A comparison of the elutriate results with the water results indicates increases in concentration of arsenic at most locations and zinc at one



location, upon elutriate preparation. Although increases are detected in arsenic and zinc, Table D4 indicates that there are no exceedances of any acute WQS or CMC for the sample locations.

Sediment concentrations of detected compounds are presented in Table D5A. A number of metals and polycyclic aromatic hydrocarbons (PAHs), and one phthalate ester (the ubiquitous Bis (2-ethylhexyl) phthalate) were detected, although few PAHs were found at the Turning Basin sampling locations.

There are no enforceable sediment quality criteria or standards with which to compare concentrations in the various sediment types. However, there are several different guidelines that are used to look for a cause for concern in sediment samples, one of which is the Effects Range Low (ERL). No ERLs were exceeded except for arsenic at a Turning Basin station (TB-11-[D, E, F]). Although the ERL was exceeded, the level did not exceed the Effects Range Medium (ERM) for arsenic, which is 70 mg/L.

### **3.2.1 Dioxins and Furans Analyses**

Dioxin and furan analyses on sediment samples were conducted for the sample locations inside the Project footprint. The results, both raw data and data normalized to total organic content of the individual sediments, are included in Table D5A. The range of un-normalized values, 2.9 to 14 pg/g dry weight, total TEQ of 2,3,7,8 tetrachlorodibenzo p Dioxin, are similar to those found in the Panhandle Bay Systems of Florida (1-78 pg/g TEQ) (USFWS, 2002) or results (1.8–11 pg/g TEQ) from Sampling for the Naval Construction Battalion Center, Gulfport, Mississippi, in November 2005 (EPA, 2006).

## **3.3 WATER QUALITY**

Standard water quality parameters were collected at 48 locations within the Project footprint, Project area, and study area of the proposed PGEP. Because the sampling was conducted over a two-day period, temperature and salinity showed little variation over the 211,000-acre area that was sampled. The lowest salinity level was recorded at Station SA 16, located at the mouth of Biloxi Bay and was 4.22 psu. This salinity reading was the only sampling location in a bay-type habitat; therefore, it was removed from further temperature analysis as shown in Table 7. The highest salinity reading was 33.39 psu, observed at Station SA 18 from the study area, located just north of the eastern tip of Ship Island. The average salinity in the Project footprint was 19.6 psu, but only 13.5 psu in the surrounding Project area. Higher salinity is typically observed in deeper areas, because salt water is denser than fresh water. This difference in salinity is likely due to the depths in the proposed Project footprint (Mean = 11.8 feet), compared to the surrounding Project area (Mean = 9.2 feet). The salinity within the entire study area averaged approximately 20 psu. This was higher than the Project footprint and the Project area, because the study area encompassed a much larger area that stretched from just south of the barrier islands to the beach (shoreline), and from the eastern tip of St. Louis Bay to the mouth of Biloxi Bay.

The average DO levels in the Project footprint, Project area, and the study area were 4.48, 6.51, and 4.76 mg/L, respectively. Difference in the DO can be attributed to the differences in water depth, as deeper water tends to exhibit lower DO values. The average water clarity ranged from 21.0 to 31.4 inches.

Table 7  
Comparison of Water Quality Data Observed During this Habitat Survey<sup>1</sup>

		Mean % (95% Confidence Interval)					
	N	Depth (m)	Bottom Temperature (°C)	Salinity (psu)	Bottom Dissolved Oxygen (mg/L)	Secchi Depth (inches)	
Footprint	PE	3	17.4 (0.3)	20.0 (0.1)	20.56 (0.34)	3.56 (<0.0)	24.0 (—)
	PM	9	8.5 (<0.0)	21.1 (<0.0)	17.6 (0.12)	5.45 (0.1)	21.3 (0.1)
	PN	2	11.5 (0.3)	20.3 (0.1)	18.16 (0.36)	6.15 (0.1)	21.0 (0.2)
	TB	6	14.4 (0.3)	20.1 (0.1)	21.58 (0.11)	3.38 (<0.0)	24.0 (—)
Project Area	9	9.2 (<0.0)	21.3 (<0.0)	13.51 (0.05)	6.51 (<0.0)	20.0 (0.1)	
Study Area	19	12.8 (<0.0)	21.2*(<0.0)	20.03 (0.12)	4.76 (<0.0)	31.4 (0.2)	

<sup>1</sup> Complete water quality data are presented in Appendix E.

\* Station SA16 was omitted from the mean and 95% Confidence Interval.

— The standard deviation is 0 and no Confidence Interval calculated.

This page intentionally left blank.

## 4.0 DISCUSSION

---

### 4.1 HABITAT SURVEY

Benthic samples were collected in 2012 from 48 locations within the Project footprint, Project area, and the study area. The data collected at these sites were used to calculate several metrics to compare the similarities and differences between the three areas sampled and the results from Ross et al. (2009). The goal of comparing these data to Ross et al. (2009) was to discern whether Gulf sturgeon habitat was present in the Project footprint of the proposed PGEP and to use the information in this report to quantify the potential impacts to Gulf sturgeon in the EIS to the extent the data will allow.

Several trends were shown in comparing the Project footprint, the Project area, and the study area. The study area had greater species diversity than the Project footprint and the Project area. It also had a slightly lower evenness value than the Project footprint and the Project area, which may indicate that more “rare” species were collected (high single species dominance) from the study area. The Project footprint and Project had similar relative abundance, species diversity, and species richness with a slightly more even distribution of species.

One reason the surrounding Project area may have a lower cumulative species richness and species diversity is that there were fewer samples collected in this area ( $n = 9$ ) compared to the study area ( $n = 19$ ) and Project footprint ( $n = 20$ ). Another reason may be that the existing operations of the Port facilities, such as routine maintenance dredging and placement activities, may have an effect on the ambient condition surrounding the existing Port facility. This is difficult to discern, as this habitat assessment was conducted one time and not over a period of months or years to capture seasonal temporal variations. The higher species richness and species diversity observed in the study area compared to the Project footprint could be due to the fact that the study area encompasses a larger area that includes near-shore habitats, Mississippi Sound, Biloxi Bay estuarine habitats, and barrier islands.

Ross et al. (2009) recorded 17 macrobenthic taxa that comprised at least 1 percent in relative abundance over the study; the 2012 study recorded 30 macrobenthic taxa that comprised at least 1 percent in relative abundance from 48 sampling locations over three sample areas. Of the taxa that comprised  $>1$  percent, seven taxa overlapped between the two studies (Table 8). The macrobenthic organisms collected in 2012 were dominated by polychaetes (four of the five most abundant organisms). However, the macrobenthic samples by Ross et al. (2009) were dominated (58.9 percent of all organisms) by Florida lancelets, sand dollars, amphipods, and bivalves. Polychaetes found by Ross et al. (2009) only totaled 7.9 percent of all organisms. The most abundant organisms recorded in 2012 were *L. fragilis* (19 percent) and *M. ambiseta* (14 percent). Ross et al. (2009) recorded the same two species, but they were much more abundant in the 2012 survey. The two data sets compared show the 2012 data have a much lower value for all of the cumulative relative abundance across all the overlapped species. Additionally, the 2012 study did not record any Florida lancelets or sand dollars from the 48 sample locations. In the Ross et al. (2009) study, the percent relative abundance of Florida lancelets was 28.7 percent.

Table 8  
Percent Relative Abundance of Species that Overlap with Ross et al. (2009)

Taxa	Ross et al. (2009)	2012				
	Cumulative	Cumulative	Project Footprint	Project Area	Study Area	Average
<i>Leitoscoloplos fragilis</i>	74.4	19.0	28.0	27.6	14.3	23.2
<i>Mediomastus ambiseta</i>	83.3	14.0	11.8	1.1	17.6	10.2
<i>Mulinia lateralis</i>	76.9	<0.1	0.4	—	—	0.1
<i>Nassarius acutus</i>	84.7	1.0	0.6	—	0.6	0.4
<i>Prionospio cristata</i>	91.6	<0.1	—	—	<0.1	<0.1
<i>Spiophanes bombyx</i>	66.8	1.0	—	—	1.3	0.4
Unidentified bivalve	71.1	<0.1	—	—	0.2	0.1

— Species was not present

The organisms with the highest relative occurrence recorded in 2012 were *L. fragilis* (85 percent) and *M. ambiseta* (27 percent), refer to Table 9. Ross et al. (2009) recorded the same two species, but they were collected much less frequently than in 2012. The two data sets compared show that the Ross et al. (2009) study had a much lower value of percent occurrence across all the overlapped species. Some of the species were only collected in the study area such as *Prionospio cristata*, *Spiophanes bombyx*, and the unidentified bivalve. These species are likely found only in bay habitat or near barrier islands.

#### 4.1.1 Seagrass

No seagrass was observed during the survey.

#### 4.1.2 Grain Size

Sediment was collected in 2012 from 48 sample locations for grain size analysis, but only 47 samples were analyzed by Anacon, Inc. Ross et al. (2009) did not run grain size analysis, but visually inspected the substratum and recorded its dominant and subdominant code. Ross et al. (2009) coded the substratum in four codes: 1—clay/mud; 2—fine sand; 3—medium to coarse sand; and 4—shell fragments. The same codes were used in 2012, and only the dominant substratum was recorded. Table 10 represents the grain size and dominant data collected in 2012 as compared to Ross et al. (2009). The substrate in the Project footprint, Project area and study area was dominated by sand; however, the sand was a fine grain as opposed to a coarse grain more typical of sturgeon habitat as recorded by Ross et al. (2009). Additionally, the locations where Gulf sturgeon were found were determined by visual inspection to be made up of at least 70 percent sand size particle, while the highest mean percentage of sand found in 2012 was 51 percent. The visual substratum code recorded in 2012 ranged from 1.3 to 1.9 (a clay mud to a fine sand), whereas the mean dominant substratum code recorded by Ross et al. (2009) was 2.6, medium

coarse sand. No coarse sand or shell fragment type substrate was found in 2012 during the visual characterization of the substrate in the Project footprint, Project area, or the study area.

Table 9  
Percent Occurrence of Species that Overlap with Ross et al. (2009)

Taxa	Ross et al. (2009)	2012				
	Cumulative	Cumulative	Project Footprint	Project Area	Study Area	Average
<i>Leitoscoloplos fragilis</i>	14.8	85.0	90.0	88.9	78.9	85.9
<i>Mediomastus ambiseta</i>	14.8	27.0	60.0	22.2	5.3	29.2
<i>Mulinia lateralis</i>	11.1	6.0	15.0	—	—	5.0
<i>Nassarius acutus</i>	18.5	13.0	15.0	—	15.8	10.3
<i>Prionospio cristata</i>	22.2	2.0	—	—	5.3	1.8
<i>Spiophanes bombyx</i>	48.1	6.0	—	—	15.8	5.3
Unidentified bivalve	40.7	8.0	—	—	21.1	7.0

— Species was not present

Table 10  
Grain Size and Substratum from Port of Gulfport Expansion Project  
Compared to Ross et al. (2009)

	N	Mean % (95% Confidence Interval)				Substratum <sup>b</sup> Mean (95% Confidence Interval)	Ross et al. (2009)	
		Sand <sup>a</sup>	Clay <sup>a</sup>	Silt <sup>a</sup>	Fines <sup>a</sup>		Dominant Substratum	Subdominant Substratum
Footprint	20	48.7 (0.4)	26.7 (0.2)	23.7 (0.2)	—	1.4 (0.1)		
Project Area	9	51.0 (0.6)	22.3 (0.3)	26.1 (0.3)	0.6 (<0.0)	1.3 (<0.0)	2.6 (0.2)	3.2 (0.3)
Study Area	18	48.4 (0.5)	22.3 (0.3)	29.0 (0.3)	—	1.9 (<0.0)		

a Anacon, Inc., Data

b Substratum are coded as 1 – clay, mud; 2 – fine sand; 3 – medium to coarse sand; 4 – shell fragments

## 4.2 SEDIMENT, WATER, AND ELUTRIATE

A number of metals (zinc and arsenic), PAHs, and one phthalate ester were detected in the proposed Project footprint. These compounds will be compared against the ambient levels that exist in nature and that have been documented during routine maintenance dredging near the Port, as further discussed in the EIS to determine whether potential negative impacts could occur from dredging and filling activities as part of the proposed Project. Based on the results shown in this report, no exceedances occurred; however, these need to be evaluated with regard to each of the organisms discussed in the EIS, each of which have a varying tolerance level to chemicals.

Dioxin and furan analyses on sediment samples were conducted for the sample locations inside the Project footprint. Both raw data and data normalized to total organic content of the individual sediments appear to be similar to ambient conditions, but this will be discussed further in the EIS.

### 4.3 WATER SURVEY

No sampling locations exhibited all the water quality habitat characteristics found in Ross et al. (2009) (depth, DO, and water clarity).

Temperature was higher during the 2012 survey in comparison to the Ross et al. (2009) study (Table 11). This difference is likely an artifact of the 2012 survey being done over a 2-day period in April instead of over several years between the months of November and April for the Ross et al. (2009) study.

The DO was overall much lower than recorded in areas where adult Gulf sturgeon were found, according to data reported in Ross et al. (2009). The mean DO recorded in Ross et al. (2009) was 7.5 mg/L as compared to 4.48 to 6.51 mg/L for the 2012 survey. However, this may be an artifact of the 2012 survey being done over a two-day period in April instead of over several years between the months of November and April.

Water clarity was also much lower in the Project footprint, Project area, and study area as compared to the Ross et al. (2009) data. However, the Ross et al. (2009) data were collected primarily between the barrier islands where tagged adult Gulf sturgeon were located, as compared to the sample design for this study which was a grid of sample locations with a wide variety of habitats.

Table 11  
Water Quality Parameters from the Proposed Port of Gulfport  
Expansion Project, Gulfport, Mississippi

	N	Depth (feet)	Mean % (95% Confidence Interval)			
			Bottom Temperature (°C)	Salinity (psu)	Bottom Dissolved Oxygen (mg/L)	Secchi depth (inches)
Project Footprint	20	11.8 (<0.0)	20.6 (<0.0)	19.61 (<0.00)	4.48 (0.1)	22.50 (0.04)
Project Area	9	9.2 (<0.0)	21.3 (<0.0)	13.51 (0.05)	6.51 (<0.0)	20.00 (0.08)
Study Area	19	12.8 (<0.0)	21.2 (<0.0)	20.03 (0.12)	4.76 (<0.0)	31.40 (0.12)
Ross et al. (2009)	40-69	12.8 (1.0)	16.0 (0.7)	22.8 (2.30)	7.5 (0.3)	77.68 (8.46)

## 5.0 CONCLUSIONS

---

Ross and other researchers in Louisiana, Mississippi, and Florida have worked diligently trying to find out as much as possible about Gulf sturgeon, including what they eat and what habitat type they prefer during overwintering. In a 2009 publication by Ross et al., they found that adult Gulf sturgeon were found at locations exhibiting the below characteristics:

- Less than 23 feet deep (mean of 13 feet)
- Well oxygenated water (mean of 7.5 mg/L)
- Clear water (mean Secchi dish transparency of 77.7 inches)
- Dominant substrates of coarse to fine sand and shell fragments
- Benthic community dominated by Florida lancelets, sand dollars, amphipods, and bivalves

None of the sampling locations visited in 2012 exhibited all the habitat characteristics found in Ross et al. (2009) (depth, DO, water clarity, benthic organisms, and substrate type). However, several sampling locations did have similar substrate type, high DO conditions, shallow depth, and an overlap of one to four benthic species with those collected during the Ross et al. (2009) study. The sampling locations that exhibited the majority of the characteristics thought to be indicative of adult Gulf sturgeon wintering habitat included two locations in the West Pier Expansion area within the Project footprint (PM-11-D and PM-11-E), one location in the Project area (PA-5), and two locations in the study area (SA-16 and SA-17). Several additional locations in the study area (SA-2, SA-7, SA-9, SA-13, and SA-18), adjacent to the barrier islands, exhibited only two characteristics but are noted here, because they showed at least three benthic species similar to Ross et al. (2009) and were dominated by sand substrate. These similarities are shown spatially on maps provided in Appendix A (Figures 5-7) and in Table 12 below.



Table 12  
Habitat Characteristics of Gulf Sturgeon Observed at Each Sampling Location<sup>1</sup>

Sample Location	Depth (feet)	Dissolved Oxygen (mg/L)	Secchi Depth (feet)	Dominant Substratum Sand	Benthic Species Overlap >2 <sup>2</sup>
<b>Footprint</b>					
PE-11-A					X (2)
PE-11-B					
PE-11-C					X (2)
PM-11-A					X (3)
PM-11-B					X (2)
PM-11-C					
<b>PM-11-D</b>	<b>X</b>	<b>X</b>		<b>X</b>	<b>X (2)</b>
<b>PM-11-E</b>	<b>X</b>	<b>X</b>		<b>X</b>	<b>X (3)</b>
PM-11-F					X (2)
PM-11-G				X	
PM-11-H					X (3)
PM-11-I				X	
PN-11-A				X	X (2)
PN-11-B				X	X (2)
TB-11-A					
TB-11-B				X	X (2)
TB-11-C				X	X (2)
TB-11-D					
TB-11-E					X (3)
TB-11-F				X	
<b>Project Area</b>					
PA-1				X	X (2)
PA-2				X	X (2)
PA-3	X	X			
PA-4				X	
<b>PA-5</b>	<b>X</b>	<b>X</b>		<b>X</b>	
PA-6				X	
PA-7					
PA-8					
PA-10				X	

Sample Location	Depth (feet)	Dissolved Oxygen (mg/L)	Secchi Depth (feet)	Dominant Substratum Sand	Benthic Species Overlap >2 <sup>2</sup>
<b>Study Area</b>					
SA-1				X	
SA-2				X	X (3)
SA-3					
SA-4				X	
SA-5					
SA-6					X (2)
<b>SA-7</b>				X	X (3)
SA-8					
<b>SA-9</b>				X	X (3)
SA-10				X	
SA-11	X	X			
SA-12					X (3)
<b>SA-13</b>				X	X (4)
SA-14					
SA-15					
<b>SA-16</b>	X	X		X	X (3)
<b>SA-17</b>	X	X			X (2)
<b>SA-18</b>				X	X (4)
SA-19	X	X			

1 X - Sample location has Gulf Sturgeon characteristics (Ross et al. 2009)

2 (#) - Number of benthic species overlap with Ross et al. (2009)

Sample location exhibits 4 of 5 habitat characteristics

Sample location exhibits 3 of 5 habitat characteristics

Macrobenthic organisms collected in 2012 from all sample areas were dominated by polychaetes. Although Ross et al. (2009) does not indicate that polychaetes are a primary food source for Gulf sturgeon in the Mississippi Sound, Brooks and Sulak (2005) indicate they are a secondary food source for juvenile Gulf sturgeon in the Suwannee River. Since the movements and habitat use of juvenile and sub-adult life history stages are not well known, a habitat comparison of the area surveyed in 2012 with the habitat used by young Gulf Sturgeon cannot be made at this time.

The inshore region of the Mississippi Sound (north of the barrier island) showed similarities in habitat characteristics used by Gulf sturgeon; however, this portion of the Sound is not used extensively by adult sturgeon according to Ross et al. (2009). It is thought that the Mississippi Sound, as well as coastal rivers and bays, such as Biloxi Bay, are likely nursery areas for younger fish (Ross et al. 2009). Four juvenile Gulf sturgeon were captured in February in Pascagoula River Estuary (Ross et al. 2003). More recently,

Havrylkoff et al. (2012) found evidence of prolonged and extensive use of the Pascagoula River mouth and immediate adjacent coastal habitats by juvenile Gulf sturgeon in April and May.

Anecdotal evidence from Ross et al. (2009) and Havrylkoff et al. (2012) show that juveniles and sub-adults may prefer estuarine and river mouth habitat for feeding. The proposed Project area is located along the shoreline in sandy, shallow, beach habitat. However, because the Port is situated between two rivers that contain Gulf sturgeon, it is likely that all life history stages, including juveniles and sub-adults, may pass near or through the Project area. Based on data collected by Peterson et al. (2015) (Appendix O of the EIS), the number of detections per fish and time within the monitoring area surrounding the proposed Project area varied greatly among all the detected Gulf sturgeon, with individuals taking both transitory paths through the area, and localized movements within the entire monitoring area. Gulf sturgeon from each life stage category were detected (adult, sub-adult, juvenile), with adults, unexpectedly, having the greatest number of occurrences and detections. The relative low occurrence of juveniles and sub-adults suggests these life history stages may experience restricted movements away from natal rivers as young fish, and only begin to expand their range later with age. On the other hand, adults have been documented within the proposed Project area during pre- and post-migratory periods, illustrating the importance of the area for the Gulf sturgeon. This suggests that the Gulfport sturgeon habitat monitored area serves as a corridor between other habitat types, drainages, feeding zones, or pre-/post-migratory acclimation zone for the Gulf sturgeon (see Appendix O of the EIS).

Based on the information gathered for this report and published data, it is unlikely that adult Gulf sturgeon would use the proposed Project footprint for feeding. Although some of the habitat characteristics are similar to Gulf sturgeon habitat in other parts of Mississippi Sound, not all habitat characteristics were present at any one sample location, and the ongoing Port operations likely deter Gulf sturgeon from persisting in this area. Additionally, published literature show adult Gulf sturgeon congregate near the barrier islands and use nearshore habitat for moving between river mouths (Ross et al., 2009; Havrylkoff et al., 2012). Therefore, adult Gulf sturgeon are likely to pass through the Project area but are not likely to feed there.

## 6.0 REFERENCES

---

- Andrews, J. 1977. *Seashells of the Texas Coast*. University of Texas Press, Austin. 298 pp.
- Brooks, R.A., and K.J. Sulak. 2005. Quantitative Assessment of Benthic Food Resources for Juvenile Gulf Sturgeon, *Acipenser oxyrinchus desotoi* in the Suwannee River Estuary, Florida, USA. *Estuaries* 28(5): 767-775.
- Brower, J.E., J.H. Zar, and C.N. von Ende. 1998. *Field and Laboratory Methods for General Ecology – Fourth Edition*. WCB/McGraw-Hill Companies.
- Dugo, M.A., B.R. Kreiser, S.T. Ross, W.T. Slack, R.J. Heise, and B.R. Bowen. 2004. Conservation and management implications of fine scale genetic structure of Gulf Sturgeon in the Pascagoula River, Mississippi. *Journal of Applied Ichthyology* 20:243-251.
- Environmental Protection Agency (EPA). 2006. *Katrina Response Environmental Soil and Sediment Sampling Gulf Coast of Mississippi October 2005, with January 2006 Addendum, Region 4, SESD, Athens, Georgia*.
- Environmental Protection Agency/U.S. Army Corps of Engineers (EPA/USACE). 1998. *Evaluation of Dredged Material Proposed for Discharge in Waters of the U.S. – Testing Manual. Inland Testing Manual. EPA-823-B-98-004. 143 pp + Appendices*.
- ERDC, Army Engineer Research and Development Center, 2012. Unpublished report, Gulf Sturgeon telemetry study in Mississippi Sound, MS Barrier Islands.
- ERDC, Army Engineer Research and Development Center, 2013. Unpublished report, Gulf Sturgeon telemetry study in Mississippi Sound, MS Barrier Islands.
- Fauchald, K. 1977. *The Polychaete Worms, Definitions and Keys to the Order, Families and Genera*. Natural History Museum of Los Angeles County. The Allan Hancock Foundation University of Southern California.
- Fox, D.A., J.E. Hightower, and F.M. Parauka. 2002. Estuarine and nearshore marine habitat use of Gulf Sturgeon from the Choctawhatchee River system, Florida, pp. 111–126. In (W Van Winkle, P.J. Anders, D.H. Secor, and D.A. Dixon, editors): *Biology, management and protection of North American sturgeon*. American Fisheries Society Symposium 28, Bethesda, Maryland.
- Gosner, K.L. 1971. *A Guide to Identification of Marine and Estuarine Invertebrates*. Cape Hatteras and the Bay of Fundy. 693 pp. New York, London, Sydney, Toronto. Wiley-Interscience, John Wiley & Sons, Ltd.
- Gu, B.E., D.M. Schell, T. Frazer, M. Hoyer, and F.A. Chapman. 2001. Stable carbon isotope evidence for reduced feeding of Gulf of Mexico sturgeon during their prolonged river residence period. *Estuarine, Coastal and Shelf* 53:275–280.

- Havrylkoff, J.M, M.S. Peterson, and W.T. Slack. 2012. Assessment of the seasonal usage of the lower Pascagoula River estuary by Gulf surgeon (*Acipenser oxyrinchus desotoi*). Applied Ichthyology. Vol 28. pp 681-686.
- Heard, R.W., J.A. McLelland, and J.M. Foster. 2002. Direct and indirect observations of the diet, seasonal occurrence, and distribution of the Gulf Sturgeon, *Acipenser oxyrinchus desotoi* Valdykov, 1955, from the Choctawhatchee Bay System, Florida, in relation to macroinvertebrate assemblages and parasites. Final report to Florida Fish and Wildlife Service.
- Heise, R.J., R.B. Bringolf, R. Patterson, and W.G. Cope. 2009. Plasma Vitellogenin and Estradiol concentrations of adult Gulf Sturgeon from the Pascagoula River Drainage, Mississippi. Transactions of the American Fisheries Society 138:1028-1035.
- Heise, R.J., W.T. Slack, S.T. Ross, and M.A. Dugo. 2004. Spawning and associated movement patterns of gulf sturgeon in the Pascagoula River Drainage. Transactions of the American Fisheries Society 133:221-230.
- . 2005. Gulf Sturgeon habitat use and fall migration in the Pascagoula River, Mississippi. USA Journal of Applied Ichthyology 21:461-468.
- Keeney, D.B., and R. Poulin. 2007. Functional Richness, Functional Evenness, and Use of Niche Space in Parasite Communities. American Society of Parasitologists 93(1): 216-219.
- Mississippi Commission on Environmental Quality (MDEQ). 2007. State of Mississippi Water Quality Criteria and Intrastate, Interstate, and Coastal Waters. Mississippi Department of Environmental Quality, Office of Pollution Control. Jackson Mississippi.
- Peterson, M.S., W.T. Slack, J.M. Havrylkoff, P.O. Grammer, and P.F. Mickle. 2015. Final Report (2012 – 2014) Gulf Sturgeon Monitoring Study for the Proposed Port of Gulfport Expansion Project, Gulfport, Mississippi. Department of Coastal Sciences, Gulf Coast Research Laboratory, University of Southern Mississippi and U.S. Army Engineer Research and Development Center, Vicksburg, Mississippi. January 2015.
- Plumb, R.H., Jr. 1981. Procedure for Handling and Chemical Analysis of Sediment and Water Samples. EPA/CE-81-1. Prepared by State University College at Buffalo, Great Lakes Laboratory, Buffalo, New York. U.S. Environmental Protection Agency and U.S. Army Corps of Engineers, Waterways Experiment Station, Vicksburg, Mississippi.
- Rakocinski, C., S.E. LeCroy, J.A. McLelland, and R.W. Heard. 1995. Macrobenthic Inventory of the Aquatic Shoreline Habitats Within the Gulf Islands National Seashore. Gulf Coast Research Laboratory, Ocean Springs, Mississippi. University of Southern Mississippi.
- Rogillio, H.E., R.T. Ruth, E.H. Behrens, C.N. Doolittle, W.J. Granger, and J.P. Kirk. 2007. Gulf Sturgeon movements in the Pearl River drainage and the Mississippi Sound. North Amer. J. Fish. Mgmt 27:89–95.

- Ross, S.T., B.R. Kreiser, W.T. Slack, M.A. Dugo, R.J. Heise, B.R. Bowen, and P. Mickle. 2003. Movement, spawning sites, habitat use, and genetic structure of Gulf Sturgeon (*Acipenser oxyrinchus desotoi*) in the Pascagoula drainage, Mississippi (Year 7). Museum Technical Report 103. Mississippi Department of Wildlife, Fisheries and Parks, Mississippi Museum of Natural Science, Jackson.
- Ross, S.T., W.T. Slack, R.J. Heise, M.A. Dugo, H. Rogillio, B.R. Bowen, P. Mickle, R.W. Heard. 2009. Estuarine and Coastal Habitat Use of Gulf Sturgeon (*Acipenser oxyrinchus desotoi*) in the North-Central Gulf of Mexico. *Estuaries and Coast* 32:360-374.
- U.S. Fish and Wildlife Service and Gulf States Marine Fisheries Commission. 1995. Gulf Sturgeon Recovery Plan. Atlanta, Georgia. 170 pp.
- U.S. Fish and Wildlife Service (USFWS). 2002. Survey of Dioxin and Furan Compounds in Sediments of Florida Panhandle Bay Systems, Publication No. PCFO-EC 02-01, USFWS, Panama City, Florida.
- U.S. Fish and Wildlife Service (USFWS) and National Oceanic and Atmospheric Administration (NOAA). 2009. Gulf Sturgeon (*Acipenser oxyrinchus desotoi*) 5-year review: Summary and Evaluation.
- World Health Organization (WHO). 2005. Toxic Equivalency Factors for Dioxins and Dioxin Like Compounds.

This page intentionally left blank.



# **Appendix A**

## **Maps**



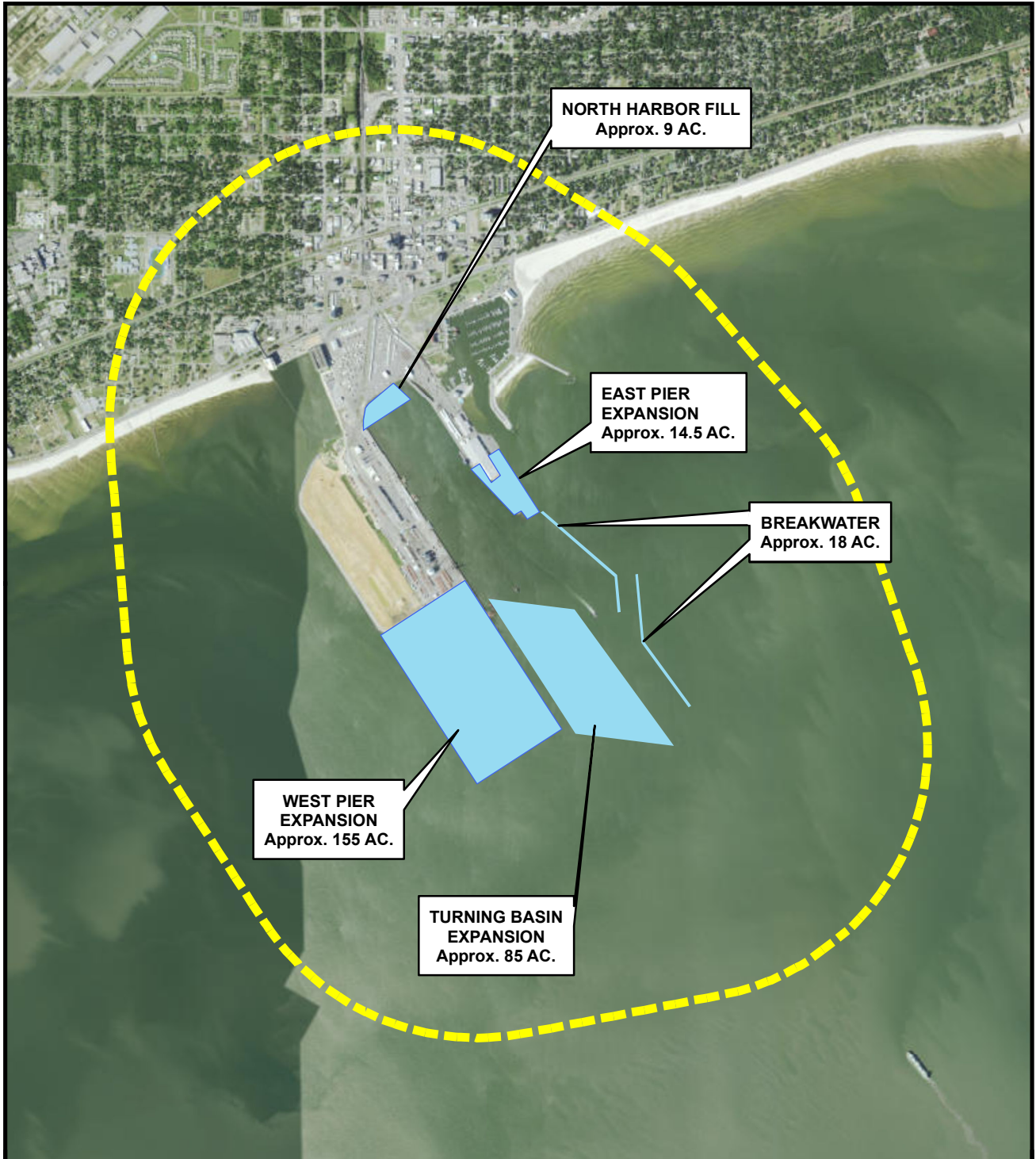



-  Project Area
-  Proposed Project Features
-  Federal Navigation Channel (FNC)



**Figure 1**  
**Port of Gulfport Expansion Project**  
**Proposed Project Features and Project Area**

Prepared By: 13188

Scale: 1" = 3000'

Job No.: 100018536

Date: Jul 24, 2015





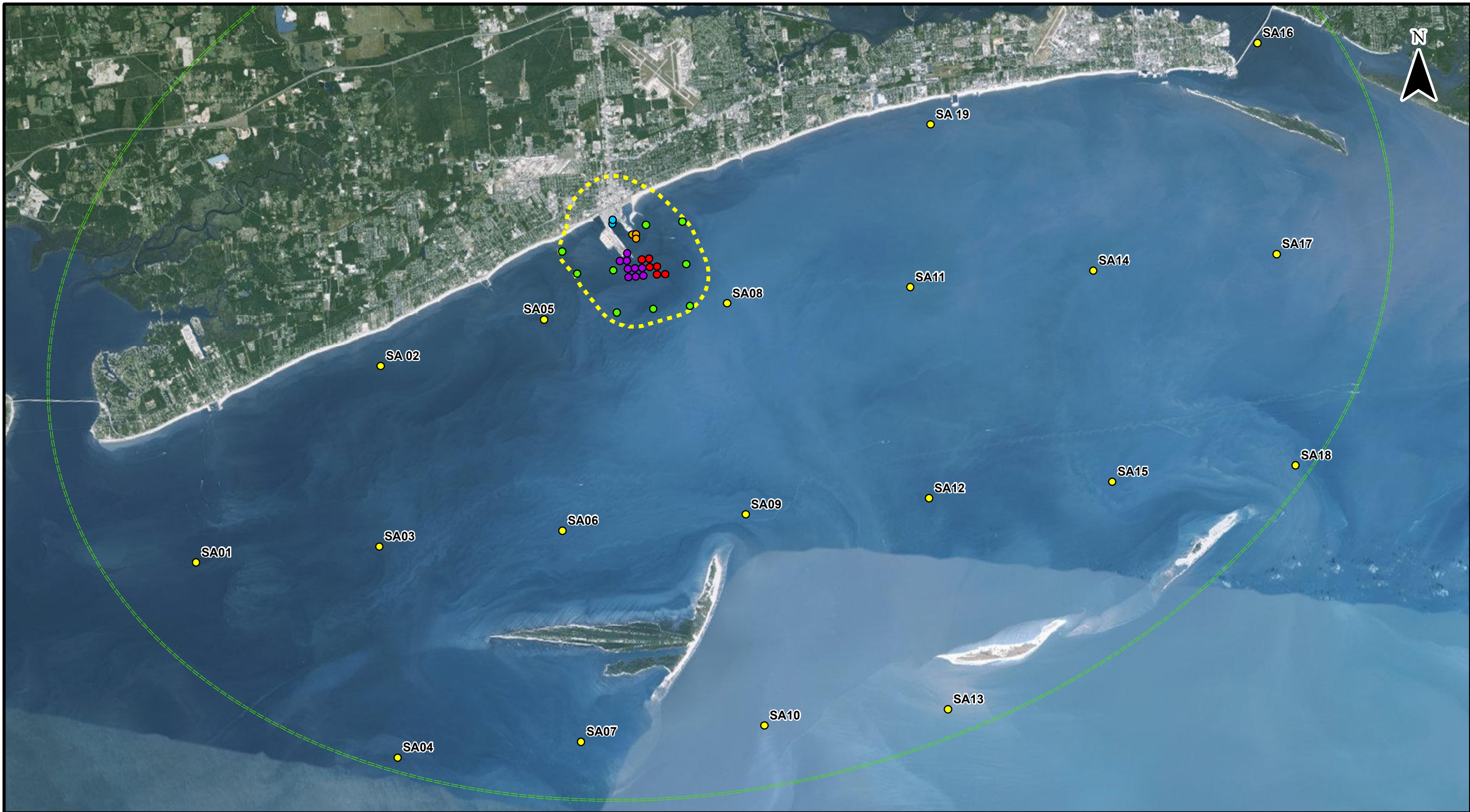

N:\Clients\MI\_N\Mississippi\_State\_Port\_Authority\100018536\geospatial\Figs\_BHA\PGEP\_BHA\_Figure\_2\_StudyArea\_Map.mxd

Source: ESRI World Imagery

**Legend**

- Study Area Sample Location (SA - 25,000 ft spacing)
- Project Area Sample Location (PA - 5,000 ft spacing)

**Project Footprint**

- Turning Basin Sample Location (TB - 1,000 ft spacing)
- West Pier Expansions Sample Location (PM - 1,000 ft spacing)
- North Harbor Fill Sample Location (PN - 500 ft spacing)
- East Pier Expansions Sample Location (PE - 500 ft spacing)

- Study Area
- Project Area

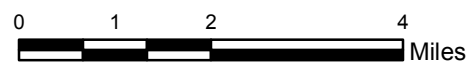

**ATKINS**

**Figure 2**  
**Study Area Map and Sample Locations**  
**Port of Gulfport Expansion Project**  
**Gulfport, Mississippi**

Project No.: 100018536	Scale: 1" = 2 miles
Drawn By: ATKINS / 13037	Date: Jul 23, 2015





Source: ESRI World Imagery

**Legend**

- Study Area Sample Location (SA - 25,000 ft spacing)
- Project Area Sample Location (PA - 5,000 ft spacing)

**Project Footprint**

- Turning Basin Sample Location (TB - 1,000 ft spacing)
- West Pier Expansions Sample Location (PM - 1,000 ft spacing)
- North Harbor Fill Sample Location (PN - 500 ft spacing)
- East Pier Expansions Sample Location (PE - 500 ft spacing)

- Project Area

- Proposed Pier Expansion

- Proposed Turning Basin Expansion

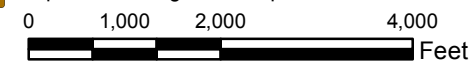

**ATKINS**

**Figure 3**  
**Project Area Map and Sample Locations**  
**Port of Gulfport Expansion Project**  
**Gulfport, Mississippi**

Project No.: 100018536

Scale: 1" = 2000'

Drawn By: ATKINS / 13037

Date: Jul 23, 2015





N:\Clients\W\_M\Mississippi\_State\_Porf\_Authority\100018536\geospatial\Figs\_BHA\PGEP\_BHA\_Figure\_4\_ProjFootprint\_and\_SampLoc.mxd

**Legend**

- Study Area Sample Location (SA - 25,000 ft spacing)
- Project Area Sample Location (PA - 5,000 ft spacing)

**Project Footprint**

- Turning Basin Sample Location (TB - 1,000 ft spacing)
- West Pier Expansions Sample Location (PM - 1,000 ft spacing)
- North Harbor Fill Sample Location (PN - 500 ft spacing)
- East Pier Expansions Sample Location (PE - 500 ft spacing)

Project Area

Proposed Pier Expansion

Proposed Turning Basin Expansion

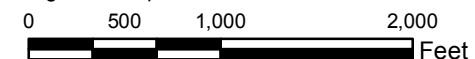

**ATKINS**

**Figure 4**  
**Project Footprint Map and Sample Locations**  
**Port of Gulfport Expansion Project**  
**Gulfport, Mississippi**

Project No.: 100018536

Scale: 1" = 1000'

Drawn By: ATKINS / 13037

Date: Jul 23, 2015



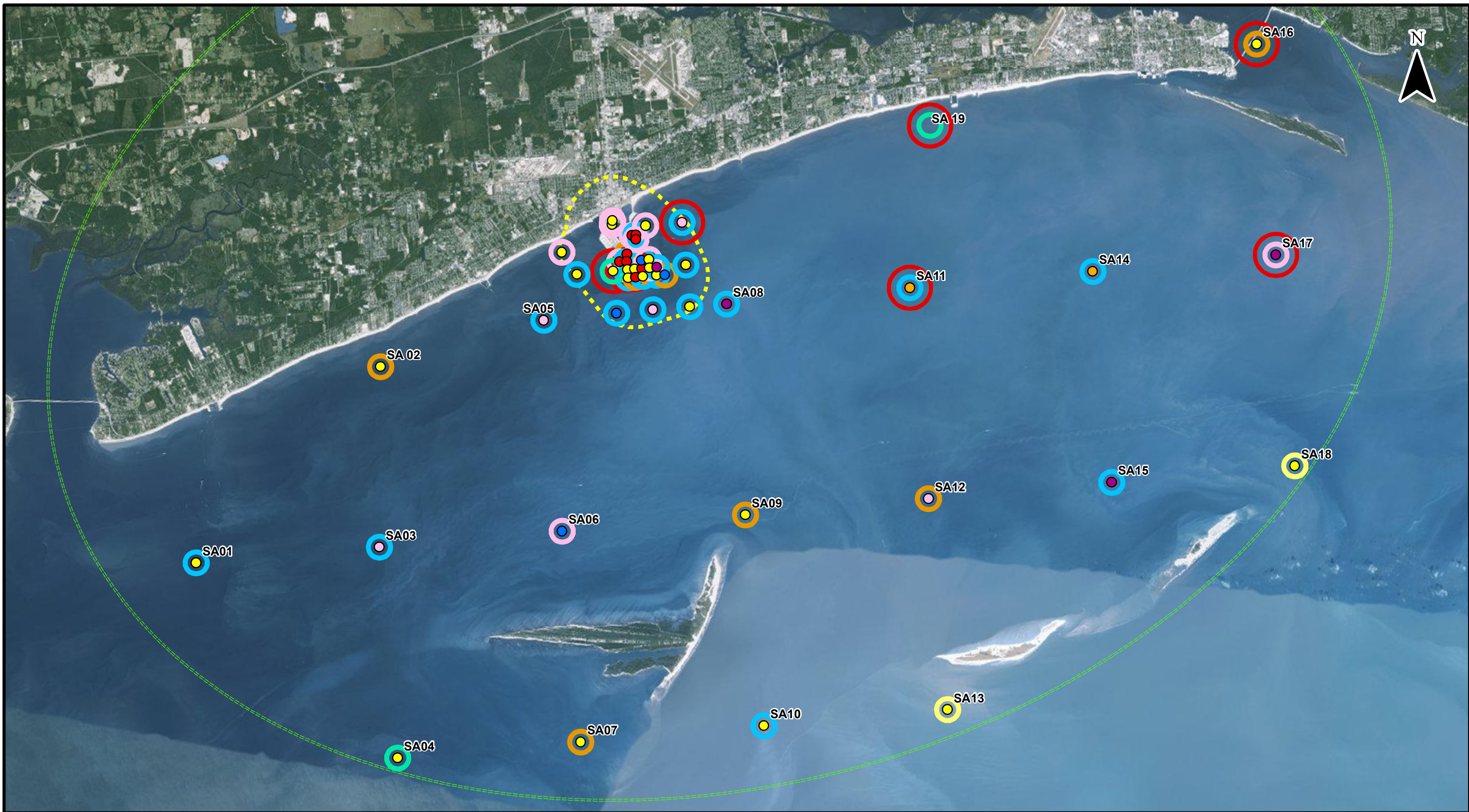

**Legend**

**Anacon Inc. Dominant Sediment Types**

- Sand
- Sand/Silt
- Sand/Clay/Silt
- Silt
- Clay/Silt
- Clay

**Number of Benthic species overlapping with Ross et al. (2009)**

- 4
- 3
- 2
- 1
- 0

Sample Locations with shallow water (< 13.5 ft) and high dissolved oxygen (DO > 7.2 mg/L)

Study Area

Project Area

Source: ESRI World Imagery

**ATKINS**

**Figure 5**  
Study Area Map showing Sample Locations with Gulf sturgeon Habitat Characteristics Port of Gulfport Expansion Project Gulfport, Mississippi

Project No.: 100018536	Scale: 1" = 2 miles
Drawn By: ATKINS / 13037	Date: Jul 23, 2015





N:\Clients\W\_M\Mississippi\_State\_Port\_Authority\100018536\geospatial\Figs\_BHA\PGEP\_BHA\_Figure\_6\_ProjectArea\_Map\_show\_SampLoc.mxd

**Legend**

Source: ESRI World Imagery

Anacon Inc. Dominant Sediment Types

- Sand
- Sand/Silt
- Sand/Clay/Silt
- Silt
- Clay/Silt
- Clay

Number of Benthic species overlapping with Ross et al. (2009)

- 4
- 3
- 2
- 1
- 0

- Sample Locations with shallow water (< 13.5 ft) and high dissolved oxygen (DO > 7.2 mg/L)

- Project Area
- Proposed Expansion
- Proposed Turning Basin Expansion

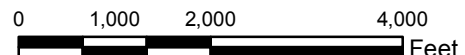

**ATKINS**

**Figure 6**  
Project Area Map showing Sample Locations with Gulf sturgeon Habitat Characteristics Port of Gulfport Expansion Project Gulfport, Mississippi

Project No.: 100018536

Scale: 1" = 2000'

Drawn By: ATKINS / 13037

Date: Jul 24, 2015





**Legend**

<b>Anacon Inc. Dominant Sediment Types</b>		<b>Number of Benthic species overlapping with Ross et al. (2009)</b>		Sample Locations with shallow water (< 13.5 ft) and high dissolved oxygen (DO > 7.2 mg/L)
Sand	Silt	4	1	
Sand/Silt	Clay/Silt	3	0	Project Area
Sand/Clay/Silt	Clay	2		Proposed Expansion
				Proposed Turning Basin Expansion

Source: ESRI World Imagery

0 500 1,000 2,000 Feet

**ATKINS**

**Figure 7**  
Project Footprint Map Showing Sample Locations with Gulf sturgeon Habitat Characteristics Port of Gulfport Expansion Project Gulfport, Mississippi

Project No.: 100018536	Scale: 1" = 1000'
Drawn By: ATKINS / 13037	Date: Jul 24, 2015



## **Appendix B**

### **Scope of Work**



**Proposed Port of Gulfport Expansion Project  
Proposed Scope of Work  
for  
Benthic Habitat Assessment of Wintering Grounds of  
Gulf Sturgeon (*Acipenser oxyrinchus desotio*) and EFH  
in the Study Area for the Proposed Gulfport Harbor Expansion Project  
Harrison County, Gulfport, Mississippi**

## **Introduction**

Atkins was contracted to write a third-party Environmental Impact Statement (EIS) for the Port of Gulfport Expansion Project. The proposed action involves dredging a new turning basin and adding new piers in three locations adjacent to the existing port (Figure 1, Attachment A).

During pre-application coordination with other agencies, Dr. Bolden from National Marine Fisheries Service (NMFS) Southeast Regional Office, Protected Resources Division, provided a list of comments to USACE Mobile District via e-mail in April 2010. The comments indicated concern for potential project-related impacts to Gulf sturgeon (*Acipenser oxyrinchus desotio*) and species with designated essential fish habitat (EFH). Additionally, during the scoping and public meetings, various agency personnel from NMFS responded with comments regarding the presence of Gulf sturgeon in the proposed project vicinity and the ability to adequately disclose potential impacts to Gulf sturgeon from the expansion with the current data set. They also responded with comments regarding the need to adequately disclose contaminants in the dredging footprint and the potential impacts from dredging on aquatic organisms (specifically, species with designated EFH).

This scope of work is being proposed to conduct a benthic habitat and epifauna survey (Habitat Survey) within the project area and study area of the Port of Gulfport Expansion Project (Figures 2 and 3, Attachment B), and a sediment, water, and elutriate analysis in the project area (Figure 2), Attachment B) in response to the agency comments mentioned above.

The objective of the Habitat Survey is to delineate the benthic (substrate type) habitat including submerged aquatic vegetation (SAV), determine the benthos present, and characterize the ambient water conditions in the project area and study area. Atkins will use similar data collection methodology and techniques used in Ross, et al, 2009, for easy comparison between this habitat survey and past and ongoing research in the study area. The results of the Habitat survey will be used to determine anticipated direct, secondary and cumulative impacts from the proposed construction and operation of the Port of Gulfport Expansion project on Gulf sturgeon and habitats designated as EFH.

The objective of the sediment, water, and elutriate sampling and analysis is to evaluate potential adverse impacts from the dredging operations performed during the construction of proposed facilities. The data collected in this scope of work will not be used in consideration the Marine Protection, Research, and Sanctuaries Act Section 103 Permit, as the proposed ODMDS site is not being evaluated under this scope of work.

## **Methods**

### Habitat Survey

Substrate will be collected using a petite Ponar dredge from each sampling location within the dredging footprint, project area, and study area. Petite Ponar dredge grabs will be collected at each sample until a minimum of 1 liter of material is obtained. Ponar grabs will be composited for each station. A visual characterization score of the dominant and subdominant substrata will

be recorded as 1 - clay, mud; 2 - fine sand; 3 - medium to coarse sand; 4 - shell fragments, per Ross, et al, (2009). Afterward, each benthic sample will be field-washed through a number 30 mesh screen and preserved in the field. Each benthos sample will be preserved in 10 percent formalin and stored in a glass jar labeled with the sample location identification number. Benthos samples will be sent to a laboratory (most likely the Gulf Coast Research Laboratory, GCRL) where each sample will be identified to the lowest practical taxonomic level and enumerated.

Substrate data will be presented in a table and depicted on a map. Benthic data will be presented in tabular format with the most abundant taxa at the top of the list and the least abundant taxa at the bottom. The average percent relative abundance, cumulative relative abundance, and percent occurrence will be calculated for the project footprint, project area, and study area.

Ambient water quality conditions will be collected one time from each sample location at the surface and 1 foot off the bottom at the time benthic data are collected. Temperature (Celsius, °C), dissolved oxygen (DO) measured in milligrams per liter (mg/L), and salinity (parts per thousand, ppt) will be collected using a YSI 6920 v2 meter. Turbidity will be measured using secchi disk in centimeters (cm). Air temperature (°C), wind speed (mile per hour, mph), and direction will be recorded with a digital altimeter. Water conditions and weather will be recorded in the field and verified using the closest on-line weather station. One water quality meter may be deployed for the duration of sampling in the study area to record any diurnal differences in ambient water conditions.

#### Sediment, Water, and Elutriate Survey

Field sampling procedures and laboratory analyses will be conducted according to the same methodology used by the U.S. Army Corps of Engineers (USACE) for routine sediment, water, and elutriate analysis prior to maintenance dredging (Environmental Protection Agency [EPA]/USACE, 1998). Additionally, all sample collections and chemical analyses will be conducted according to the Mississippi Department of Environmental Quality (MSDEQ) State of Mississippi Water Quality Criteria for Intrastate, Interstate, and Coastal Waters (MsDEQ, 2007). Prior to sample collection, all containers and sampling equipment will be cleaned according to protocols described in Plumb (1981) or other appropriate guidance manuals. Care will be taken to avoid contamination to sampling devices from the boat deck or other surfaces. Powderless latex gloves will be worn during sample collection.

Sample locations identified in Gulfport Harbor will be taken from four areas within the port, including the turning basin (TB), the main pier expansion (PM), east pier expansion (PE), and the north pier expansion (PN) (Figure 2, Attachment B). All sample locations will be located and documented using a hand-held Garmin 76 CS Global Positioning System accurate to <5 meters. Coordinates for all locations will be included in a table and submitted with the findings report. Sediment samples (surface grab samples) will be collected at each of the four dredging footprints and will occur approximately every 500–1,000 linear feet, depending on the area.

The sample number, matrix and analysis to be run are shown in Table 1 below. Samples will be collected so that three sub samples will be composited into one sample in the PE area; two subsamples will be composited into one sample in the PN area; eight subsamples will be composited into three samples to the PM area; and five subsamples will be composited into two samples for the TB.

Prior to sample collection with a surface grab, all residual sediment will be removed from the dredge with a brush. The dredge will be rinsed with deionized water and then with ambient water. Each sample will be deposited into a clean polyethylene pan. Composite samples will be mixed thoroughly and then placed into a pre-cleaned glass jar. The jar will be filled completely to avoid headspace and ensure the total sample volume. The lid will be tightly secured and placed into a cooler with ice.

Water samples will be collected one time using a suitable non-metallic bilge pump with a food-grade hose and a peristaltic pump. The depth of each water sample will be at the surface, mid-depth, and to one-third of the way to the bottom. Prior to filling sample containers, the pump will be allowed to run and purge the existing hose from any previous samples to ensure water collected was representative of the sample location. Water samples will then be collected in polyethylene and glass bottles provided by laboratory. Water samples to be analyzed for metals will be collected using a variable-speed peristaltic pump and Teflon tubing. Water samples to be analyzed for metals other than mercury and selenium will be filtered through a clean 0.45- $\mu\text{m}$  filter prior to dispensing into containers. Pre-cleaned brown glass bottles will be used for organic analyses. All bottles will contain the appropriate preservatives and will be filled completely to avoid headspace.

**Table 1: Sampling Nomenclature, Matrix, and Location**

<b>Sample Number</b>	<b>GPS Location</b>	<b>Sample Matrix</b>	<b>Analyses</b>
<b>Pier Expansion</b>			
PE-11-A	TBD	Sediment, Water	W,S, E, GS,
PE-11-B	TBD	Sediment, Water	Component of PE station above
PE-11-C	TBD	Sediment, Water	Component of PE stations above
PN-11-A	TBD	Sediment, Water	W,S, E, GS,
PN- 1-B	TBD	Sediment, Water	Component of PN station above
PM-11-3A	TBD	Sediment, Water	W, S, E, GS
PM-11-3B	TBD	Sediment, Water	Component of PM station above
PM-11-3C	TBD	Sediment, Water	Component of PM stations above
PM-11-3D	TBD	Sediment, Water	W, S, E, GS
PM-11-3E	TBD	Sediment, Water	Component of PM station above
PM-11-3F	TBD	Sediment, Water	Component of PM stations above
PM-11-3G	TBD	Sediment, Water	W, S, E, GS
PM-11-3H	TBD	Sediment, Water	Component of PM station above
<b>Basin Expansion</b>			
TB-11-A	TBD	Water, Sediment	W, S, E, GS
TB-11-B	TBD	Sediment	Component of BE station above
TB-11-C	TBD	Sediment, Water	Component of BE stations above
TB-11-E	TBD	Sediment	W, S, E, GS
TB-11-F	TBD	Sediment	Component of BE station above

Elutriates for chemical analyses will be prepared from sediment and water collected at sample sites 500 linear feet apart. Sediment and water will be a combined at a 1:4 ratio, respectively, and prepared as designated in EPA/USACE (1998) by laboratory personnel.

During sediment collections, water chemistry, elutriates, and in situ standard water quality parameters will also be recorded at each sample site. A YSI 600 Series multi-parameter instrument will be used to measure water quality parameters, which include: dissolved oxygen (mg/L), pH (SU), salinity (ppt), water temperature (°C), air temperature (°C), and water depth (feet). In addition to water quality parameters, ambient water and weather conditions will be recorded. Multi-parameter water quality instrument calibrations were performed before and after sampling according to MDEQ's SWQM Procedure Manual.

### Analyses for Dioxins and Furans

All sediment samples will be analyzed for the dioxins and furans listed in the table below. Laboratory results will be reported as TEQ. The laboratory will use WHO 2005 TEF to calculate TEQ. The target detection limits for each individual congener will be 0.1 pg/g dry weight for sediment. Higher detection limits may be acceptable if these detection limits cannot be met.

**Table 2: Dioxin and Furan Congeners to be Analyzed in the Gulfport Expansion Project Area**

Analyte	CAS Numbers	EPA Method
<b>Polychlorinated Dibenzo-p-dioxins</b>		
2,3,7,8 - Tetrachloro Dibenzo- <i>p</i> -Dioxin	1746-01-6	1613, 8280b, or 8290a
1,2,3,7,8 - Pentachloro Dibenzo- <i>p</i> -Dioxin	40321-76-4	1613, 8280b, or 8290a
1,2,3,4,7,8 - Hexachloro Dibenzo- <i>p</i> -Dioxin	39227-28-6	1613, 8280b, or 8290a
1,2,3,6,7,8 - Hexachloro Dibenzo- <i>p</i> -Dioxin	57653-85-7	1613, 8280b, or 8290a
1,2,3,7,8,9 - Hexachloro Dibenzo- <i>p</i> -Dioxin	19408-74-3	1613, 8280b, or 8290a
1,2,3,4,6,7,8 - Heptachloro Dibenzo- <i>p</i> -Dioxin	35822-46-9	1613, 8280b, or 8290a
Octachloro Dibenzo- <i>p</i> -Dioxin	3268-87-9	1613, 8280b, or 8290a
<b>Polychlorinated Dibenzofurans</b>		
2,3,7,8 - Tetrachloro Dibenzo- <i>p</i> -Furan	51207-31-9	1613, 8280b, or 8290a
1,2,3,7,8 - Pentachloro Dibenzo- <i>p</i> -Furan	57117-41-6	1613, 8280b, or 8290a
2,3,4,7,8 - Pentachloro Dibenzo- <i>p</i> -Furan	57117-31-4	1613, 8280b, or 8290a
1,2,3,4,7,8 - Hexachloro Dibenzo- <i>p</i> -Furan	70648-26-9	1613, 8280b, or 8290a
1,2,3,6,7,8 - Hexachloro Dibenzo- <i>p</i> -Furan	57117-44-9	1613, 8280b, or 8290a
2,3,4,6,7,8 - Hexachloro Dibenzo- <i>p</i> -Furan	60851-34-5	1613, 8280b, or 8290a
1,2,3,7,8,9 - Hexachloro Dibenzo- <i>p</i> -Furan	72918-21-9	1613, 8280b, or 8290a
1,2,3,4,6,7,8 - Heptachloro Dibenzo- <i>p</i> -Furan	67562-39-4	1613, 8280b, or 8290a
1,2,3,4,7,8,9 - Heptachloro Dibenzo- <i>p</i> -Furan	55673-89-7	1613, 8280b, or 8290a
Octachloro Dibenzo- <i>p</i> -Furan	39001-02-0	1613, 8280b, or 8290a

### Sample Preservation and Storage

Collected samples will be cooled and stored at 2 to 4°C until laboratory analysis. Analyses will be performed within the recommended holding times, as described in the referenced guidance documents.

### Chain of Custody

A chain of custody will be completed according to appropriate guidance manuals and accompany the samples until laboratory analysis.

### Chemical Analyses

Each composite sample will be analyzed for water, sediment, and elutriate conditions. All chemical analyses will be performed by Anacon, which is accredited for the analytes/analyte groups and matrices analyzed by the TCEQ, an accrediting authority recognized by the National Environmental Laboratory Accreditation Program (NELAP). The constituents for which analyses will be conducted, the methods used, and the Method Detection Limits are provided in Attachment C.

### **Results**

#### Habitat Survey

Results from this survey will be summarized in a report. The habitat will be presented in a map and data will be presented with tables and graphs as necessary. A draft report will be sent out for review, and comments will be addressed before the final report is submitted.

#### Sediment, Water and Elutriate Analysis

Results from the sampling effort will be compiled into tables and summarized. Any analysis that results in levels that would potentially cause negative impacts to Gulf sturgeon or species with designated EFH in the project vicinity will be discussed and impacts will be disclosed in the EIS. Potential impacts will be described by each category of EFH affected and life stages of fish and invertebrate species potentially affected by the action. Secondary and cumulative effects on EFH and associated fishery species will also be described.

### **Cost**

The cost for completing the scope of work outlined above would be done on a time a materials basis not to exceed \$ 101,785.00.

<b>Task</b>	<b>Cost</b>
<b>Labor</b>	<b>\$ 46,922.02</b>
<b>Field Effort &amp; Reporting Expenses</b>	<b>\$ 10,911.50</b>
<b>Laboratory Analysis</b>	<b>\$ 42,203.40</b>
<b>Total</b>	<b>\$ 100,036.92</b>



## Literature Cited

---



- Plumb, R. H., Jr. 1981. Procedure for Handling and Chemical Analysis of Sediment and Water Samples. EPA/CE-81-1. Prepared by State University College at Buffalo, Great Lakes Laboratory, Buffalo, New York. U.S. Environmental Protection Agency and U.S. Army Corps of Engineers, Waterways Experiment Station, Vicksburg, Mississippi.
- Ross, S. T., W. T. Slack, R. J. Heise, M. A. Dugo, H. Rogillio, B. R. Bowen, P. Mickle, and R. W. Heard. 2009. Estuarine and coastal habitat use of Gulf sturgeon (*Acipenser oxyrinchus desotoi*) in the North-Central Gulf of Mexico. *Estuaries and Coasts*. 32: 360-374.
- U.S. Army Corps of Engineers (Waterways Experiment Station). 1998. Use of Sediment Quality Guidelines (SQG's) in Dredged Material Management. Dredging Research Technical Note EEDP-04-29.
- U.S. Environmental Protection Agency/U.S. Army Corps of Engineers (EPA/USACE). 1998. Evaluation of Dredged Material Proposed for Discharge in Waters of the U.S. – Testing Manual. Inland Testing Manual. EPA-823-B-98-004. 143pp + Appendices.

## **Attachment A**

### **Figure 1**

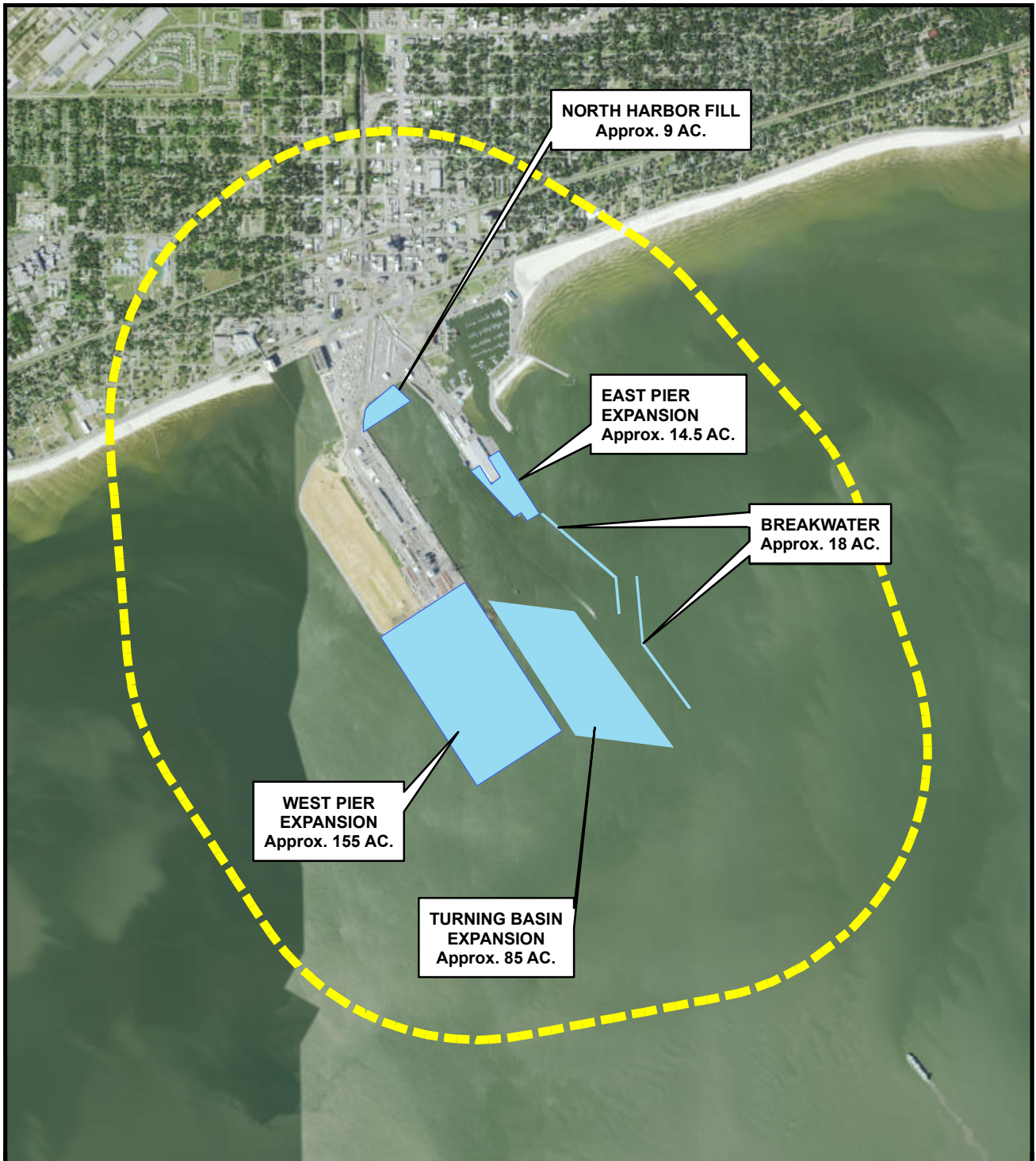



-  Project Area
-  Proposed Project Features
-  Federal Navigation Channel (FNC)



**Figure 1**

**Port of Gulfport Expansion Project**

**Proposed Project Features and Project Area**

Prepared By: 13188	Scale: 1" = 3000'
Job No.: 100018536	Date: Jul 24, 2015



**Attachment B**

**Figures 2 and 3**



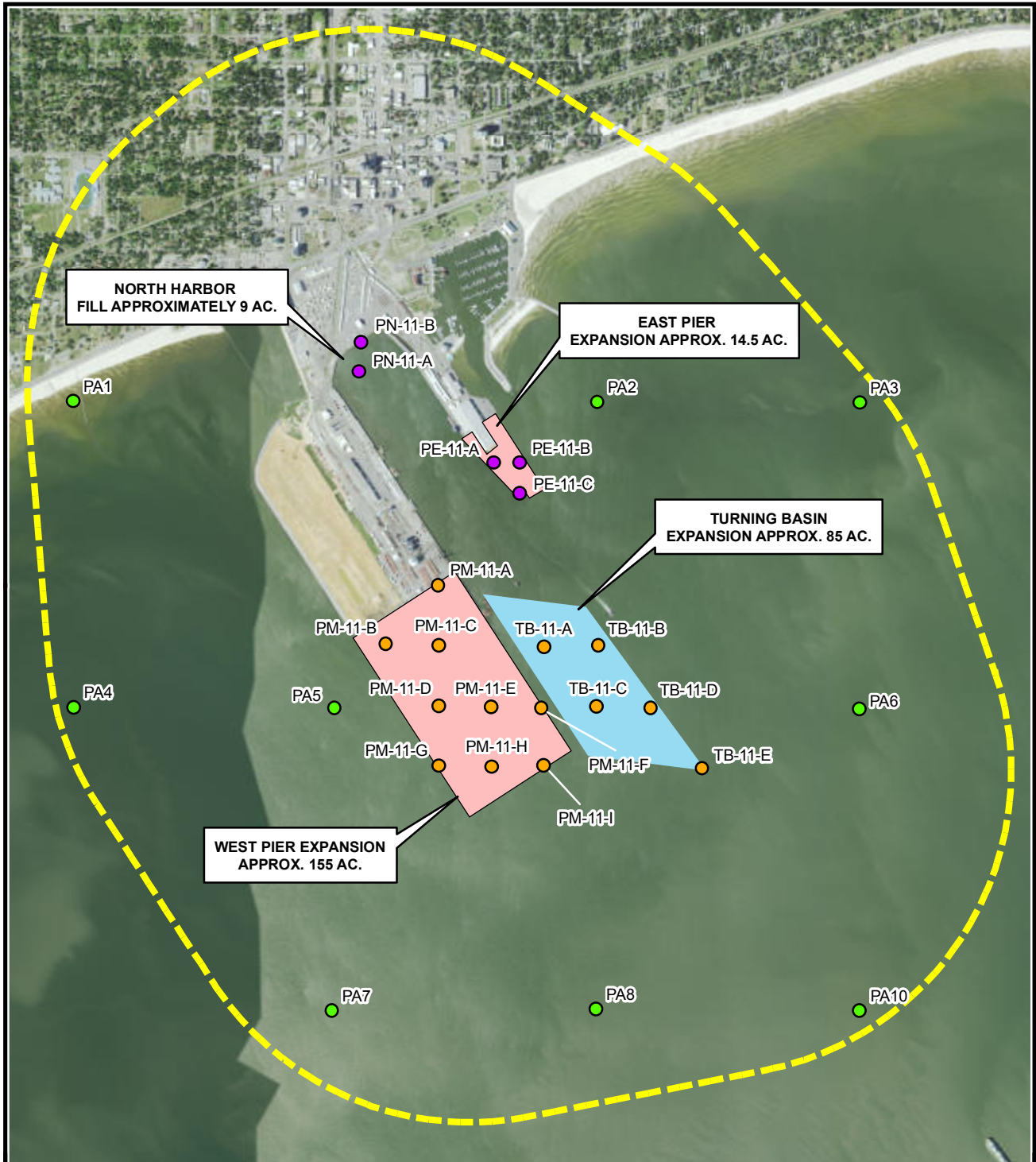

- North and East Pier (500 ft Transects)
- Project Area (5,000 ft Transects)
- South Pier and Turning Basin (1,000 ft Transects)
- Proposed Turning Basin Expansion
- Proposed Pier Expansion
- Project Area



Source: ESRI World Imagery

**Figure 2**  
**Port of Gulfport Expansion Project**  
**Project Area Proposed Sampling**

Prepared By: 24125	Scale: 1" = 2500'
Job No.: 100018536	Date: Jul 24, 2015



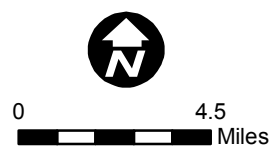
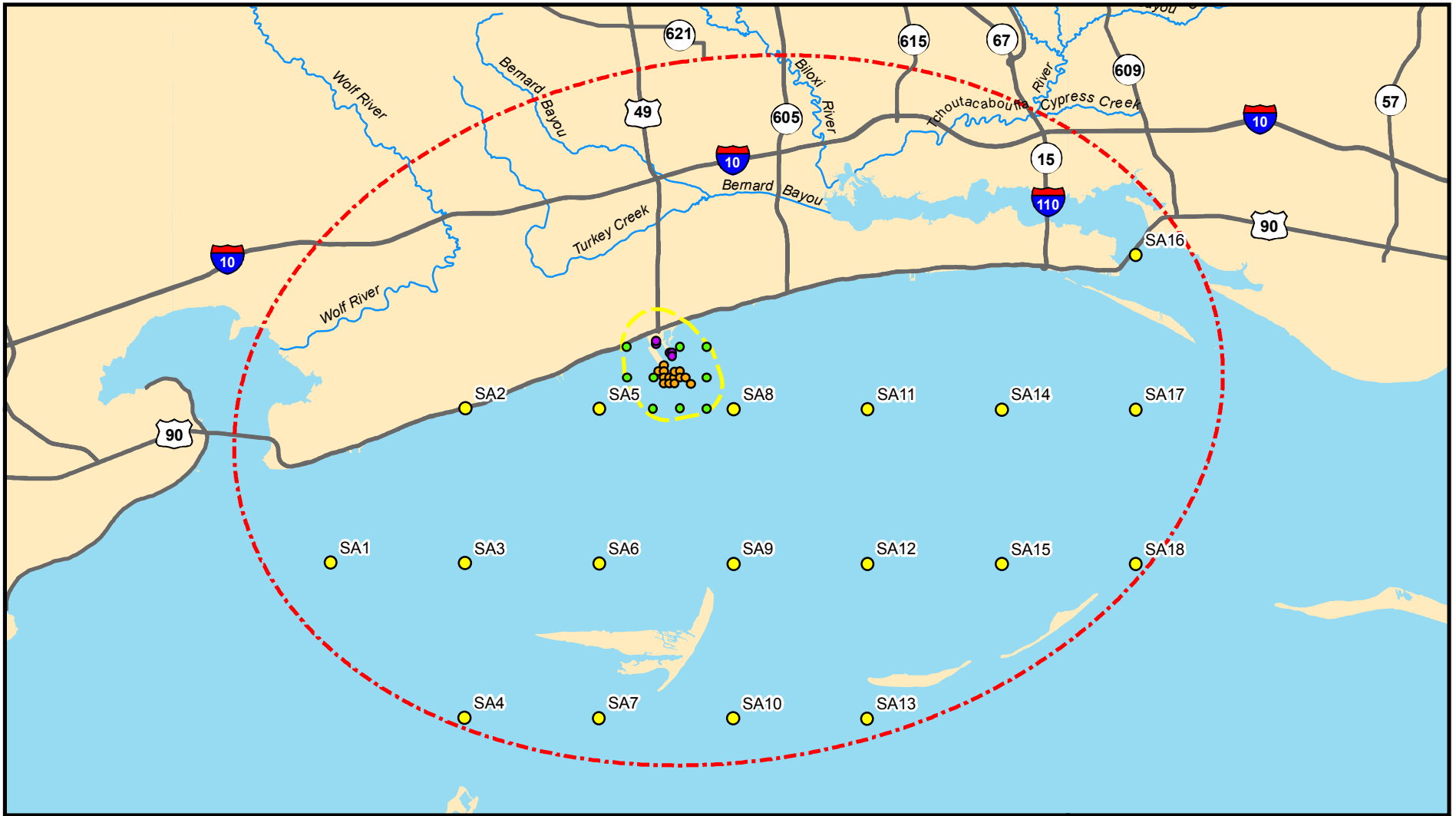

- North and East Pier (500 ft Transects)
- Project Area (5,000 ft Transects)
- South Pier and Turning Basin (1,000 ft Transects)
- Study Area (25,000 ft Transects)
- Project Area
- Study Area

**Figure 3**  
**Port of Gulfport Expansion Project**  
**Study Area Proposed Sampling**

Prepared By: 24125	Scale: 1" = 4.5 miles
Job No.: 100018536	Date: Jul 24, 2015

## **Attachment C**

### **Detection Limits**



**Analytical Methodology and Minimum Detection Limits**

<b>Parameter</b>	<b>Contract Required Detection Limit</b>	<b>Units</b>	<b>EPA Method</b>
<b><u>Water and Elutriate</u></b>			
<b><u>Metals</u></b>			
Antimony	3.00	ug/L	200.8**
Arsenic	1.00	ug/L	200.8**
Beryllium	0.20	ug/L	200.8**
Cadmium	1.00	ug/L	200.8**
Chromium, Total	1.00	ug/L	200.8**
Chromium, Trivalent	1.00	ug/L	200.8**
Chromium, Hexavalent	1.00	ug/L	200.8**
Copper	1.00	ug/L	200.8**
Lead	1.00	ug/L	200.8**
Mercury	0.20	ug/L	200.8**
Nickel	1.00	ug/L	200.8**
Selenium	2.00	ug/L	200.8**
Silver	1.00	ug/L	200.8**
Thallium	1.00	ug/L	200.8**
Zinc	1.00	ug/L	200.8**
<b><u>Pesticides and PCB's</u></b>			
Aldrin	0.03	ug/L	608*
Alpha-BHC	0.03	ug/L	608*
Beta-BHC	0.03	ug/L	608*
Gamma-BHC (Lindane)	0.03	ug/L	608*
Delta-BHC	0.03	ug/L	608*
Chlordane	0.03	ug/L	608*
Alpha-Chlordane	0.03	ug/L	608*
Gamma- Chlordane	0.03	ug/L	608*
4,4'-DDD	0.10	ug/L	608*
4,4'-DDE	0.10	ug/L	608*
4,4'-DDT	0.10	ug/L	608*
Dieldrin	0.02	ug/L	608*
Endosulfan I	0.10	ug/L	608*
Endosulfan II	0.10	ug/L	608*
Endosulfan sulfate	0.10	ug/L	608*
Endrin	0.10	ug/L	608*
Endrin aldehyde	0.10	ug/L	608*
Heptachlor	0.10	ug/L	608*
Heptachlor epoxide	0.10	ug/L	608*
Toxaphene	0.50	ug/L	608*
<b>Total PCB's</b>	<b>0.01</b>	<b>ug/L</b>	<b>608*</b>

**Analytical Methodology and Minimum Detection Limits**

Parameter	Contract Required Detection Limit	Units	EPA Method
<b><u>Water and Elutriate</u></b>			
<b><u>Semivolatiles</u></b>			
Acenaphthene	0.75	ug/L	625*
Acenaphthylene	1.00	ug/L	625*
Anthracene	0.60	ug/L	625*
Benzidine	1.00	ug/L	625*
Benzo(a)anthracene	0.40	ug/L	625*
Benzo(a)pyrene	0.30	ug/L	625*
Benzo(ghi)perylene	1.20	ug/L	625*
Benzo(b&k)fluoranthene	0.60	ug/L	625*
Bis(2-chloroethoxy)methane	1.00	ug/L	625*
Bis(2-chloroethyl)ether	0.90	ug/L	625*
Bis(2-chloroisopropyl)ether	0.70	ug/L	625*
Bis(2-ethylhexyl)phthalate	2.00	ug/L	625*
4-Bromophenyl phenyl ether	0.40	ug/L	625*
Butyl benzyl phthalate	4.00	ug/L	625*
4-chloro-3-methylphenol	0.70	ug/L	625*
2-Chloronaphthalene	0.80	ug/L	625*
2-Chlorophenol	0.90	ug/L	625*
4-Chlorophenyl phenyl ether	0.60	ug/L	625*
Chrysene	0.30	ug/L	625*
Dibenzo(ah)anthracene	1.30	ug/L	625*
Dibutyl phthalate	1.00	ug/L	625*
1,2-Dichlorobenzene	0.80	ug/L	625*
1,3-Dichlorobenzene	0.90	ug/L	625*
1,4-Dichlorobenzene	1.00	ug/L	625*
3,3-Dichlorobenzidene	3.00	ug/L	625*
2,4-Dichlorophenol	0.80	ug/L	625*
Diethyl phthalate	1.00	ug/L	625*
2,4-Dimethylphenol	10.0	ug/L	625*
Dimethyl phthalate	1.00	ug/L	625*
2,4-Dinitrophenol	5.00	ug/L	625*
Dimethyl phthalate	50.0	ug/kg	8270C
2,4-Dinitrophenol	500	ug/kg	8270C
2,4-Dinitrotoluene	200	ug/kg	8270C
2,6-Dinitrotoluene	200	ug/kg	8270C
Di-n-octyl phthalate	50.0	ug/kg	8270C

**Analytical Methodology and Minimum Detection Limits**

<b>Parameter</b>	<b>Contract Required Detection Limit</b>	<b>Units</b>	<b>EPA Method<sup>1</sup></b>
<b><u>Sediment</u></b>			
1,2-Diphenylhydrazine	10.0	ug/kg	8270C
Fluoranthene	20.0	ug/kg	8270C
Fluorene	20.0	ug/kg	8270C
Hexachlorobenzene	10.0	ug/kg	8270C
Hexachlorobutadiene	20.0	ug/kg	8270C
Hexachlorocyclopentadiene	300	ug/kg	8270C
Hexachloroethane	100	ug/kg	8270C
Indeno(123-CD)pyrene	20.0	ug/kg	8270C
Isophorone	10.0	ug/kg	8270C
2-Methyl-4,6-dinitrophenol	600	ug/kg	8270C
Naphthalene	20.0	ug/kg	8270C
Nitrobenzene	160	ug/kg	8270C
2-Nitrophenol	200	ug/kg	8270C
4-Nitrophenol	500	ug/kg	8270C
N-nitrosodimethylamine	20.0	ug/kg	8270C
N-nitrosodi-n-propylamine	150	ug/kg	8270C
N-nitrosodiphenylamine	20.0	ug/kg	8270C
Phenanthrene	20.0	ug/kg	8270C
Phenol	100	ug/kg	8270C
Pentachlorophenol	100	ug/kg	8270C
Pryene	20.0	ug/kg	8270C
1,2,4-Trichlorobenzene	10.0	ug/kg	8270C
2,4,6-Trichlorophenol	140	ug/kg	8270C
<b><u>Conventional Parameters*</u></b>			
Total Organic Carbon	0.1	%	9060
Total Petroleum Hydrocarbons	5.00	mg/kg	8021
Cyanide	2.00	mg/kg	SM-4500 CN-/335.2
Ammonia	0.10	mg/kg	350.3
<b>Total Solids</b>	-	%	160.3

<sup>1</sup> U.S. EPA, "Test Methods for the Evaluation of Solid Waste," SW-846, Latest Edition.

\* Sediments only.



**Appendix C**  
**Benthic Data**





# ATKINS

Macrobenthic Organisms Collected from the Proposed Port of Gulfport Expansion Project, Gulfport  
Mississippi

Site ID	LPIL	Taxon	Number present
PE-11-A	S	<i>Amphicteis floridus</i>	1
	S	<i>Balanoglossus aurantiacus</i>	1
	S	<i>Chione inta purpurea</i>	1
	S	<i>Glycinde solitaria</i>	1
	F	Hesionidae	3
	S	<i>Leitoscoloplos fragilis*</i>	45
	S	<i>Mediomastus ambiseta*</i>	4
	S	<i>Paraprionospio pinnata</i>	3
	P	Nemertea (LPIL)	2
	S	<i>Sigambra tentaculata</i>	1
	S	<i>Tharyx acutus</i>	2
<b>Total</b>			<b>64</b>
PE-11-B	S	<i>Glycinde solitaria</i>	3
	S	<i>Leitoscoloplos fragilis*</i>	4
	S	<i>Paraprionospio pinnata</i>	1
	P	Nemertea (LPIL)	1
<b>Total</b>			<b>9</b>
PE-11-C	F	Hesionidae	1
	S	<i>Leitoscoloplos fragilis*</i>	1
	S	<i>Mediomastus ambiseta*</i>	1
	S	<i>Paraprionospio pinnata</i>	1
	F	Phyllodocidae (LPIL)	1
	P	Nemertea (LPIL)	2
	S	<i>Sigambra tentaculata</i>	1
	S	<i>Spiochaetopterus oculatus</i>	1
	S	<i>Streblospio benedicti</i>	2
	G	<i>Stylochus</i> (LPIL)	1
<b>Total</b>			<b>12</b>
PM-11-A	S	<i>Acteocina canaliculata</i>	1
	S	<i>Balanoglossus aurantiacus</i>	4
	S	<i>Glycinde solitaria</i>	2
	S	<i>Leitoscoloplos fragilis*</i>	2
	S	<i>Mediomastus ambiseta*</i>	3
	S	<i>Nassarius acutus*</i>	2
	S	<i>Sigambra tentaculata</i>	1
	<b>Total</b>		
PM-11-B	S	<i>Acteocina canaliculata</i>	1
	S	<i>Amphicteis floridus</i>	1
	O	Copepoda (LPIL)	1
	S	<i>Glycera americana</i>	1
	S	<i>Glycinde solitaria</i>	5
	F	Hesionidae	1

LPIL - Lowest Practical Identification Level

\* Taxa overlap with species identified in Ross et al. 2009

P = Phylum; C = Class; O = Order; F = Family; G = Genus; S = Species

PN : 100018536

# ATKINS

Macrobenthic Organisms Collected from the Proposed Port of Gulfport Expansion Project, Gulfport  
Mississippi

Site ID	LPIL	Taxon	Number present
PM-11-B	S	<i>Leitoscoloplos fragilis</i> *	8
	S	<i>Mediomastus ambiseta</i> *	1
	S	<i>Paraprionospio pinnata</i>	3
	P	Nemertea (LPIL)	3
	S	<i>Sigambra tentaculata</i>	2
	S	<i>Spiochaetopterus oculatus</i>	2
	G	<i>Stylochus</i> (LPIL)	1
<b>Total</b>			<b>30</b>
PM11C	S	<i>Glycera americana</i>	1
	S	<i>Leitoscoloplos fragilis</i> *	3
	O	Nudibranchia	1
	S	<i>Paraprionospio pinnata</i>	4
	S	<i>Pectinaria gouldii</i>	1
	P	Nemertea (LPIL)	1
	S	<i>Spiochaetopterus oculatus</i>	1
<b>Total</b>			<b>12</b>
PM-11-D	S	<i>Glycinde solitaria</i>	2
	S	<i>Mediomastus ambiseta</i> *	4
	S	<i>Mulinia lateralis</i> *	1
	S	<i>Myriochele oculata</i>	2
	F	Mysidaceae (LPIL)	1
	P	Nematoda	1
	G	<i>Oxyurostylis</i> (LPIL)	1
	S	<i>Pagurus pollicaris</i>	1
	G	<i>Pagurus</i> (LPIL)	1
	P	Nemertea (LPIL)	2
<b>Total</b>			<b>16</b>
PM-11-E	S	<i>Acteocina canaliculata</i>	38
	S	<i>Glycinde solitaria</i>	2
	S	<i>Leitoscoloplos fragilis</i> *	1
	S	<i>Mediomastus ambiseta</i> *	15
	S	<i>Mulinia lateralis</i> *	1
	F	Mysidaceae (LPIL)	1
	S	<i>Paraprionospio pinnata</i>	1
	S	<i>Pectinaria gouldii</i>	3
	P	Nemertea (LPIL)	15
<b>Total</b>			<b>77</b>
PM-11-F	S	<i>Acteocina canaliculata</i>	2
	S	<i>Glycinde solitaria</i>	1
	S	<i>Leitoscoloplos fragilis</i> *	5
	S	<i>Nassarius acutus</i> *	1
	S	<i>Paraprionospio pinnata</i>	2

LPIL - Lowest Practical Identification Level

\* Taxa overlap with species identified in Ross et al. 2009

P = Phylum; C = Class; O = Order; F = Family; G = Genus; S = Species

PN : 100018536

# ATKINS

Macrobenthic Organisms Collected from the Proposed Port of Gulfport Expansion Project, Gulfport  
Mississippi

Site ID	LPIL	Taxon	Number present
PM-11-F	S	<i>Pectinaria gouldii</i>	1
	P	Nemertea (LPIL)	1
	S	<i>Spiochaetopterus oculatus</i>	1
	G	<i>Stylochus</i> (LPIL)	1
<b>Total</b>			<b>15</b>
PM-11-G	S	<i>Capitella capitata</i>	1
	S	<i>Cossura soyeri</i>	1
	S	<i>Glycinde solitaria</i>	2
	S	<i>Mediomastus ambiseta</i> *	6
	S	<i>Pectinaria gouldii</i>	1
	P	Phoronida (LPIL)	3
	P	Nemertea (LPIL)	5
	S	<i>Teinostoma biscaynense</i>	1
<b>Total</b>			<b>20</b>
PM-11-H	S	<i>Acteocina canaliculata</i>	1
	S	<i>Balanoglossus aurantiacus</i>	1
	S	<i>Cossura soyeri</i>	1
	S	<i>Glycera americana</i>	1
	S	<i>Glycinde solitaria</i>	2
	F	Hesionidae	3
	S	<i>Leitoscoloplos fragilis</i> *	3
	S	<i>Paraprionospio pinnata</i>	2
	P	Nemertea (LPIL)	4
	S	<i>Spiochaetopterus oculatus</i>	2
<b>Total</b>			<b>20</b>
PM-11-I	S	<i>Acteocina canaliculata</i>	9
	O	Actinaria (LPIL)	1
	S	<i>Amygdalium papyria</i>	1
	S	<i>Balanoglossus aurantiacus</i>	4
	S	<i>Capitella capitata</i>	4
	S	<i>Glycinde solitaria</i>	7
	S	<i>Leitoscoloplos fragilis</i> *	1
	S	<i>Mediomastus ambiseta</i> *	1
	S	<i>Nassarius acutus</i> *	1
	C	Oligochaeta (LPIL)	2
	S	<i>Paraprionospio pinnata</i>	1
	P	Nemertea (LPIL)	3
<b>Total</b>			<b>35</b>
PN-11-A	S	<i>Balanoglossus aurantiacus</i>	6
	S	<i>Cossura soyeri</i>	2
	S	<i>Glycinde solitaria</i>	3
	S	<i>Leitoscoloplos fragilis</i> *	8

LPIL - Lowest Practical Identification Level

\* Taxa overlap with species identified in Ross et al. 2009

P = Phylum; C = Class; O = Order; F = Family; G = Genus; S = Species

PN : 100018536

# ATKINS

Macrobenthic Organisms Collected from the Proposed Port of Gulfport Expansion Project, Gulfport  
Mississippi

Site ID	LPIL	Taxon	Number present
PN-11-A	S	<i>Mediomastus ambiseta</i> *	1
	S	<i>Paraprionospio pinnata</i>	3
	G	<i>Pinnixa</i> (LPIL)	1
	P	Nemertea (LPIL)	3
	S	<i>Sigambra tentaculata</i>	1
<b>Total</b>			<b>28</b>
PN-11-B	S	<i>Acteocina canaliculata</i>	3
	O	Decapoda (LPIL)	2
	S	<i>Leitoscoloplos fragilis</i> *	2
	S	<i>Mediomastus ambiseta</i> *	39
	S	<i>Myriochele oculata</i>	1
	S	<i>Pectinaria gouldii</i>	1
	P	Nemertea (LPIL)	1
	S	<i>Streblospio benedicti</i>	13
	G	<i>Stylochus</i> (LPIL)	1
<b>Total</b>			<b>63</b>
TB-11-A	S	<i>Balanoglossus aurantiacus</i>	7
	S	<i>Capitella capitata</i>	1
	S	<i>Cossura soyeri</i>	4
	S	<i>Glycinde solitaria</i>	2
	S	<i>Leitoscoloplos fragilis</i> *	22
	C	Oligochaeta (LPIL)	2
	P	Nemertea (LPIL)	3
	S	<i>Streblospio benedicti</i>	2
<b>Total</b>			<b>43</b>
TB-11-B	S	<i>Acteocina canaliculata</i>	5
	S	<i>Balanoglossus aurantiacus</i>	6
	F	Cirratulidae (LPIL)	1
	S	<i>Glycinde solitaria</i>	4
	S	<i>Leitoscoloplos fragilis</i> *	9
	S	<i>Mediomastus ambiseta</i> *	6
	F	Nereidae (LPIL)	1
	G	<i>Oxyurostylis</i> (LPIL)	1
	S	<i>Paramphinome</i> (LPIL)	3
	S	<i>Paraprionospio pinnata</i>	1
	G	<i>Phoronis</i> (LPIL)	3
	G	<i>Pinnixa</i> (LPIL)	1
	C	Polychaeta (LPIL)	1
	P	Nemertea (LPIL)	3
<b>Total</b>			<b>45</b>
TB-11-C	S	<i>Acteocina canaliculata</i>	3
	O	Actinaria (LPIL)	1

LPIL - Lowest Practical Identification Level

\* Taxa overlap with species identified in Ross et al. 2009

P = Phylum; C = Class; O = Order; F = Family; G = Genus; S = Species

PN : 100018536

# ATKINS

Macrobenthic Organisms Collected from the Proposed Port of Gulfport Expansion Project, Gulfport  
Mississippi

Site ID	LPIL	Taxon	Number present
TB-11-C	S	<i>Balanoglossus aurantiacus</i>	2
	S	<i>Glycinde solitaria</i>	6
	S	<i>Leitoscoloplos fragilis*</i>	1
	S	<i>Mulinia lateralis*</i>	1
	F	Nereidae (LPIL)	1
	P	Nemertea (LPIL)	1
	<b>Total</b>		
TB-11-D	S	<i>Acteocina canaliculata</i>	1
	S	<i>Amygdalium papyria</i>	1
	S	<i>Balanoglossus aurantiacus</i>	5
	S	<i>Capitella capitata</i>	2
	F	Cirratulidae (LPIL)	1
	O	Decapoda (LPIL)	1
	S	<i>Glycinde solitaria</i>	3
	S	<i>Leitoscoloplos fragilis*</i>	28
	G	<i>Oxyurostylis</i> (LPIL)	1
	P	Nemertea (LPIL)	4
<b>Total</b>			<b>47</b>
TB-11-E	O	Actinaria (LPIL)	3
	S	<i>Americamysis stucki</i>	1
	S	<i>Balanoglossus aurantiacus</i>	4
	P	Chaetognatha	2
	S	<i>Cossura soyeri</i>	29
	S	<i>Glycinde solitaria</i>	2
	S	<i>Leitoscoloplos fragilis*</i>	54
	S	<i>Mediomastus ambiseta*</i>	4
	G	<i>Naineris</i> (LPIL)	5
	F	Nereidae (LPIL)	2
	C	Oligochaeta (LPIL)	2
	S	<i>Paraprionospio pinnata</i>	4
	G	<i>Phoronis</i> (LPIL)	3
	C	Polychaeta (LPIL)	1
	P	Nemertea (LPIL)	1
	S	<i>Sigambra tentaculata</i>	10
	<b>Total</b>		
TB-11-F	S	<i>Acteocina canaliculata</i>	2
	S	<i>Balanoglossus aurantiacus</i>	5
	S	<i>Capitella capitata</i>	1
	S	<i>Glycinde solitaria</i>	8
	C	Hydrozoa (LPIL)	1
	S	<i>Leitoscoloplos fragilis*</i>	5
	C	Oligochaeta (LPIL)	2

LPIL - Lowest Practical Identification Level

\* Taxa overlap with species identified in Ross et al. 2009

P = Phylum; C = Class; O = Order; F = Family; G = Genus; S = Species

PN : 100018536

# ATKINS

Macrobenthic Organisms Collected from the Proposed Port of Gulfport Expansion Project, Gulfport  
Mississippi

Site ID	LPIL	Taxon	Number present
TB-11-F	S	<i>Paraprionospio pinnata</i>	2
	P	Nemertea (LPIL)	1
<b>Total</b>			<b>27</b>
PA01	S	<i>Acteocina canaliculata</i>	1
	S	<i>Glycinde solitaria</i>	3
	S	<i>Hypereteone heteropoda</i>	1
	S	<i>Leitoscoloplos fragilis*</i>	7
	S	<i>Mediomastus ambiseta*</i>	3
	G	<i>Monoculodes</i> (LPIL)	1
	F	Mysidaceae (LPIL)	4
	G	<i>Oxyurostylis</i> (LPIL)	5
	S	<i>Pectinaria gouldii</i>	1
	S	<i>Polydora cornuta</i>	2
	P	Nemertea (LPIL)	7
<b>Total</b>			<b>35</b>
PA 02	S	<i>Cossura soyeri</i>	1
	S	<i>Glycinde solitaria</i>	3
	P	Isopoda	1
	S	<i>Leitoscoloplos fragilis*</i>	7
	S	<i>Mediomastus ambiseta*</i>	1
	S	<i>Myriochele oculata</i>	5
	S	<i>Paraprionospio pinnata</i>	1
	P	Nemertea (LPIL)	2
	S	<i>Spiochaetopterus oculatus</i>	1
<b>Total</b>			<b>22</b>
PA 03	O	Actinaria (LPIL)	1
	S	<i>Cossura soyeri</i>	2
	S	<i>Glycinde solitaria</i>	12
	S	<i>Leitoscoloplos fragilis*</i>	9
	G	<i>Magelona</i> (LPIL)	2
	S	<i>Paraprionospio pinnata</i>	1
	P	Nemertea (LPIL)	8
<b>Total</b>			<b>35</b>
PA 04	S	<i>Balanoglossus aurantiacus</i>	4
	S	<i>Glycinde solitaria</i>	6
	G	<i>Hermandura</i> (LPIL)	1
	S	<i>Hypereteone heteropoda</i>	1
	S	<i>Leitoscoloplos fragilis*</i>	8
	G	<i>Pinnixa</i> (LPIL)	1
	F	Sabellariidae (LPIL)	1
	S	<i>Sigambra bassi</i>	2
<b>Total</b>			<b>24</b>

LPIL - Lowest Practical Identification Level

\* Taxa overlap with species identified in Ross et al. 2009

P = Phylum; C = Class; O = Order; F = Family; G = Genus; S = Species

PN : 100018536

# ATKINS

Macrobenthic Organisms Collected from the Proposed Port of Gulfport Expansion Project, Gulfport  
Mississippi

Site ID	LPIL	Taxon	Number present
PA 05	O	Amphipoda (LPIL)	6
	S	<i>Astrangia poculata</i>	2
	F	Balanidae (LPIL)	1
	S	<i>Balanoglossus aurantiacus</i>	2
	G	<i>Bowmaniella</i> (LPIL)	4
	S	<i>Capitella capitata</i>	18
	P	Chaetognatha	13
	C	Hydrozoa (LPIL)	4
	S	<i>Hypereteone heteropoda</i>	1
	P	Nematoda	1
	F	Nereidae (LPIL)	3
	G	<i>Oxyurostylis</i> (LPIL)	1
	C	Polychaeta (LPIL)	1
	P	Nemertea (LPIL)	33
	G	<i>Stylochus</i> (LPIL)	1
<b>Total</b>			<b>91</b>
PA 06	S	<i>Acteocina canaliculata</i>	1
	O	Actinaria (LPIL)	18
	S	<i>Cossura soyeri</i>	1
	S	<i>Glycinde solitaria</i>	7
	S	<i>Leitoscoloplos fragilis</i> *	16
	P	Nemertea (LPIL)	5
	S	<i>Spiochaetopterus oculatus</i>	1
<b>Total</b>			<b>49</b>
PA 07	S	<i>Acteocina canaliculata</i>	1
	S	<i>Glycinde solitaria</i>	2
	F	Hesionidae	1
	S	<i>Leitoscoloplos fragilis</i> *	15
	S	<i>Monoculodes sp. D</i>	1
	G	<i>Oxyurostylis</i> (LPIL)	2
	S	<i>Paraprionospio pinnata</i>	2
	S	<i>Polydora ligni</i>	1
	S	<i>Sigambra tentaculata</i>	1
	G	<i>Stylochus</i> (LPIL)	1
<b>Total</b>			<b>27</b>
PA08	S	<i>Acteocina canaliculata</i>	1
	S	<i>Cossura soyeri</i>	2
	S	<i>Glycinde solitaria</i>	4
	S	<i>Leitoscoloplos fragilis</i> *	18
	S	<i>Paraprionospio pinnata</i>	1
	S	<i>Phascolion strombi</i>	1
	S	<i>Phyllodoce mucosa</i>	1

LPIL - Lowest Practical Identification Level

\* Taxa overlap with species identified in Ross et al. 2009

P = Phylum; C = Class; O = Order; F = Family; G = Genus; S = Species

PN : 100018536



# ATKINS

Macrobenthic Organisms Collected from the Proposed Port of Gulfport Expansion Project, Gulfport  
Mississippi

Site ID	LPIL	Taxon	Number present
PA08	P	Nemertea (LPIL)	1
<b>Total</b>			<b>29</b>
PA 10	O	Actinaria (LPIL)	7
	S	<i>Amphicteis floridus</i>	1
	S	<i>Cossura soyeri</i>	3
	S	<i>Glycinde solitaria</i>	12
	S	<i>Leitoscoloplos fragilis*</i>	19
	S	<i>Paraprionospio pinnata</i>	1
	P	Nemertea (LPIL)	3
	S	<i>Spiochaetopterus oculatus</i>	1
<b>Total</b>			<b>47</b>
SA 01	S	<i>Acteocina canaliculata</i>	7
	S	<i>Ampelisca abdita</i>	1
	S	<i>Glycinde solitaria</i>	13
	G	Hermandura (LPIL)	1
	S	<i>Leitoscoloplos fragilis*</i>	6
	G	<i>Leucon</i> (LPIL)	1
	F	Nereidae (LPIL)	2
	G	<i>Oxyurostylis</i> (LPIL)	2
	S	<i>Pectinaria gouldii</i>	1
	P	Nemertea (LPIL)	4
	<b>Total</b>		
SA 02	O	Actinaria (LPIL)	1
	C	Bivalvia (LPIL)*	1
	O	Copepoda	1
	S	<i>Cossura soyeri</i>	3
	O	Decapoda (LPIL)	1
	S	<i>Edotea triloba</i>	1
	S	<i>Glycera americana</i>	9
	S	<i>Glycinde solitaria</i>	17
	S	<i>Leitoscoloplos fragilis*</i>	17
	S	<i>Mediomastus ambiseta*</i>	6
	G	<i>Monoculodes</i> (LPIL)	1
	F	Mysidaceae (LPIL)	3
	G	<i>Oxyurostylis</i> (LPIL)	1
	S	<i>Parandalia tricuspis</i>	2
	S	<i>Paraprionospio pinnata</i>	2
	S	<i>Pectinaria gouldii</i>	16
	S	<i>Phascolion strombi</i>	1
	P	Phoronida (LPIL)	1
	S	<i>Phyllodoce mucosa</i>	1
	P	Nemertea (LPIL)	5

LPIL - Lowest Practical Identification Level

\* Taxa overlap with species identified in Ross et al. 2009

P = Phylum; C = Class; O = Order; F = Family; G = Genus; S = Species

PN : 100018536

# ATKINS

Macrobenthic Organisms Collected from the Proposed Port of Gulfport Expansion Project, Gulfport  
Mississippi

Site ID	LPIL	Taxon	Number present
SA 02	S	<i>Sigambra tentaculata</i>	5
	S	<i>Spiochaetopterus oculatus</i>	1
	S	<i>Streblospio benedicti</i>	2
	G	<i>Stylochus</i> (LPIL)	1
<b>Total</b>			<b>99</b>
SA 03	S	<i>Acteocina canaliculata</i>	1
	O	Actinaria (LPIL)	2
	S	<i>Cossura soyeri</i>	8
	S	<i>Glycinde solitaria</i>	4
	F	Hesionidae	2
	S	<i>Leitoscoloplos fragilis*</i>	18
	G	<i>Magelona</i> (LPIL)	1
	S	<i>Paraprionospio pinnata</i>	1
	P	Nemertea (LPIL)	1
	S	<i>Sigambra tentaculata</i>	1
	S	<i>Spiochaetopterus oculatus</i>	1
<b>Total</b>			<b>40</b>
SA 04	S	<i>Acteocina canaliculata</i>	1
	O	Actinaria (LPIL)	9
	S	<i>Amphicteis floridus</i>	1
	S	<i>Gammarus mucronatus</i>	1
	S	<i>Glycera americana</i>	2
	G	<i>Magelona</i> (LPIL)	5
	S	<i>Nereis falsa</i>	10
	S	<i>Ophiophragmus moorei</i>	2
	S	<i>Owenia fusiformis</i>	1
	S	<i>Phyllodoce mucosa</i>	1
	G	<i>Pinnixa</i> (LPIL)	1
	P	Nemertea (LPIL)	2
	S	<i>Sigambra tentaculata</i>	5
<b>Total</b>			<b>41</b>
SA 05	O	Actinaria (LPIL)	14
	S	<i>Ampelisca abdita</i>	1
	S	<i>Cossura soyeri</i>	1
	S	<i>Glycinde solitaria</i>	11
	S	<i>Leitoscoloplos fragilis*</i>	26
	S	<i>Pectinaria gouldii</i>	1
	P	Nemertea (LPIL)	2
	S	<i>Spiochaetopterus oculatus</i>	1
<b>Total</b>			<b>57</b>
SA 06	S	<i>Acteocina canaliculata</i>	1
	S	<i>Balanoglossus aurantiacus</i>	2

LPIL - Lowest Practical Identification Level

\* Taxa overlap with species identified in Ross et al. 2009

P = Phylum; C = Class; O = Order; F = Family; G = Genus; S = Species

PN : 100018536

# ATKINS

Macrobenthic Organisms Collected from the Proposed Port of Gulfport Expansion Project, Gulfport  
Mississippi

Site ID	LPIL	Taxon	Number present
SA 06	P	Chaetognatha	3
	S	<i>Cossura soyeri</i>	6
	S	<i>Glycinde solitaria</i>	5
	F	Hesionidae	5
	S	<i>Leitoscoloplos fragilis*</i>	24
	S	<i>Mediomastus ambiseta*</i>	1
	S	<i>Paraprionospio pinnata</i>	1
	S	<i>Phascolion strombi</i>	1
	P	Nemertea (LPIL)	4
	S	<i>Sigambra tentaculata</i>	2
	O	Decapoda (LPIL)	3
	<b>Total</b>		
SA 07	O	Actinaria (LPIL)	1
	S	<i>Americamysis alleni</i>	2
	S	<i>Americamysis bahia</i>	1
	O	Amphipoda (LPIL)	2
	S	<i>Balanoglossus aurantiacus</i>	45
	G	<i>Callinectes</i> (LPIL)	1
	G	<i>Ceratoneis</i> (LPIL)	1
	O	Cumacea (LPIL)	3
	S	<i>Edotea triloba</i>	1
	S	<i>Glycinde solitaria</i>	15
	S	<i>Hypereteone heteropoda</i>	1
	S	<i>Leitoscoloplos fragilis*</i>	2
	S	<i>Macoma tenta</i>	2
	G	<i>Magelona</i> (LPIL)	28
	S	<i>Mediomastus ambiseta*</i>	83
	S	<i>Notomastus hemipodus</i>	1
	C	Oligochaeta (LPIL)	13
	C	Ophiuroidea (LPIL)	1
	G	<i>Oxyurostylis</i> (LPIL)	1
	S	<i>Paraprionospio pinnata</i>	7
	S	<i>Pectinaria gouldii</i>	2
	G	<i>Pinnixa</i> (LPIL)	6
	C	Polychaeta (LPIL)	1
	P	Nemertea (LPIL)	43
F	Sabellariidae (LPIL)	6	
S	<i>Sigambra tentaculata</i>	17	
S	<i>Spiophanes bombyx*</i>	2	
<b>Total</b>			<b>288</b>
SA 08	O	Actinaria (LPIL)	2
	P	Chaetognatha	1

LPIL - Lowest Practical Identification Level

\* Taxa overlap with species identified in Ross et al. 2009

P = Phylum; C = Class; O = Order; F = Family; G = Genus; S = Species

PN : 100018536

# ATKINS

Macrobenthic Organisms Collected from the Proposed Port of Gulfport Expansion Project, Gulfport  
Mississippi

Site ID	LPIL	Taxon	Number present
SA 08	S	<i>Cossura soyeri</i>	10
	O	Decapoda (LPIL)	4
	S	<i>Glycinde solitaria</i>	11
	S	<i>Leitoscoloplos fragilis*</i>	29
	S	<i>Leitoscoloplos robustus</i>	4
	G	<i>Magelona</i> (LPIL)	2
	F	Mysidacae (LPIL)	1
	G	<i>Oxyurostylis</i> (LPIL)	1
	S	<i>Paraprionospio pinnata</i>	2
	G	<i>Pinnixa</i> (LPIL)	1
	P	Nemertea (LPIL)	3
	S	<i>Sigambra tentaculata</i>	3
	S	<i>Spiochaetopterus oculatus</i>	1
<b>Total</b>			<b>75</b>
SA 09	S	<i>Acteocina canaliculata</i>	16
	S	<i>Amphicteis floridus</i>	3
	O	Amphipoda (LPIL)	2
	S	<i>Balanoglossus aurantiacus</i>	3
	S	<i>Capitella capitata</i>	2
	O	Copepoda	1
	S	<i>Cossura soyeri</i>	2
	S	<i>Edotea triloba</i>	1
	S	<i>Glycinde solitaria</i>	3
	S	<i>Leitoscoloplos fragilis*</i>	15
	S	<i>Macoma tenta</i>	1
	G	<i>Magelona</i> (LPIL)	13
	S	<i>Mediomastus ambiseta*</i>	23
	S	<i>Myriochele oculata</i>	1
	F	Mysidacae (LPIL)	3
	G	<i>Notomastus</i> (LPIL)	1
	G	<i>Oxyurostylis</i> (LPIL)	1
	S	<i>Paraprionospio pinnata</i>	1
	S	<i>Phyllodoce mucosa</i>	1
	S	<i>Pinnixa chaetopterus</i>	4
	S	<i>Polydora cornuta</i>	1
	S	<i>Prionospio cristata*</i>	1
	P	Nemertea (LPIL)	23
	S	<i>Sigambra tentaculata</i>	13
	S	<i>Spiochaetopterus oculatus</i>	2
	O	Decapoda (LPIL)	1
<b>Total</b>			<b>138</b>
SA 10	S	<i>Acteocina canaliculata</i>	1

LPIL - Lowest Practical Identification Level

\* Taxa overlap with species identified in Ross et al. 2009

P = Phylum; C = Class; O = Order; F = Family; G = Genus; S = Species

PN : 100018536

# ATKINS

Macrobenthic Organisms Collected from the Proposed Port of Gulfport Expansion Project, Gulfport  
Mississippi

Site ID	LPIL	Taxon	Number present
SA 10	O	Actinaria (LPIL)	2
	O	Amphipoda (LPIL)	1
	S	<i>Ancistrosyllis jonesi</i>	2
	S	<i>Balanoglossus aurantiacus</i>	8
	S	<i>Capitella capitata</i>	1
	P	Chaetognatha	1
	S	<i>Glycinde solitaria</i>	12
	S	<i>Leitoscoloplos fragilis*</i>	6
	G	<i>Magelona</i> (LPIL)	5
	C	Oligochaeta (LPIL)	1
	G	<i>Paramphinome</i> (LPIL)	2
	S	<i>Paraprionospio pinnata</i>	10
	S	<i>Sigambra tentaculata</i>	12
	F	Tomopteridae (LPIL)	1
<b>Total</b>			<b>65</b>
SA 11	S	<i>Acteocina canaliculata</i>	1
	S	<i>Balanoglossus aurantiacus</i>	4
	S	<i>Capitella capitata</i>	4
	S	<i>Cossura soyeri</i>	9
	S	<i>Glycinde solitaria</i>	6
	S	<i>Leitoscoloplos fragilis*</i>	63
	G	<i>Magelona</i> (LPIL)	3
	G	<i>Ophichthus</i> (LPIL)	1
	G	<i>Oxyurostylis</i> (LPIL)	1
	S	<i>Paraprionospio pinnata</i>	1
	G	<i>Phoronis</i> (LPIL)	3
	F	Pilargidae (LPIL)	1
	G	<i>Pinnixa</i> (LPIL)	4
	P	Nemertea (LPIL)	8
	S	<i>Sigambra tentaculata</i>	10
G	<i>Stylochus</i> (LPIL)	1	
<b>Total</b>			<b>120</b>
SA 12	P	Chaetognatha	1
	O	Copepoda	1
	S	<i>Cossura soyeri</i>	1
	O	Decapoda (LPIL)	1
	S	<i>Glycinde solitaria</i>	1
	S	<i>Leitoscoloplos fragilis*</i>	16
	G	<i>Magelona</i> (LPIL)	7
	S	<i>Mediomastus ambiseta*</i>	7
	S	<i>Nassarius acutus*</i>	1
	G	<i>Notomastus</i> (LPIL)	1

LPIL - Lowest Practical Identification Level

\* Taxa overlap with species identified in Ross et al. 2009

P = Phylum; C = Class; O = Order; F = Family; G = Genus; S = Species

PN : 100018536

# ATKINS

Macrobenthic Organisms Collected from the Proposed Port of Gulfport Expansion Project, Gulfport  
Mississippi

Site ID	LPIL	Taxon	Number present
SA 12	S	<i>Paraprionospio pinnata</i>	3
	S	<i>Phascolion strombi</i>	1
	S	<i>Pinnixa chaetopterus</i>	1
	P	Nemertea (LPIL)	8
	S	<i>Sigambra tentaculata</i>	13
	S	<i>Spiochaetopterus oculatus</i>	1
<b>Total</b>			<b>64</b>
SA 13	O	Amphipoda (LPIL)	3
	S	<i>Anadera transversa</i>	1
	S	<i>Armandia maculata</i>	1
	C	Bivalvia (LPIL)*	2
	S	<i>Chione inta purpurea</i>	1
	S	<i>Glycera americana</i>	3
	S	<i>Glycinde solitaria</i>	9
	S	<i>Heteromastus filiformis</i>	1
	S	<i>Mediomastus ambiseta*</i>	89
	F	Mysidaceae (LPIL)	3
	S	<i>Nassarius acutus*</i>	1
	G	<i>Notomastus</i> (LPIL)	1
	F	Ophiuroidea (LPIL)	1
	S	<i>Owenia fusiformis</i>	1
	G	<i>Oxyurostylis</i> (LPIL)	11
	S	<i>Pandora trilineata</i>	3
	S	<i>Paraprionospio pinnata</i>	12
	S	<i>Phyllodoce mucosa</i>	1
	P	Nemertea (LPIL)	13
	F	Sigalionidae (LPIL)	1
	S	<i>Sigambra tentaculata</i>	23
	S	<i>Spiophanes bombyx*</i>	1
	F	Tellinidae (LPIL)	8
S	<i>Tharyx acutus</i>	7	
O	Decapoda (LPIL)	1	
<b>Total</b>			<b>198</b>
SA 14	S	<i>Armandia maculata</i>	1
	O	Copepoda	1
	S	<i>Cossura soyeri</i>	8
	S	<i>Glycinde solitaria</i>	11
	S	<i>Leitoscoloplos fragilis*</i>	39
	G	<i>Magelona</i> (LPIL)	7
	S	<i>Myriochele oculata</i>	2
	G	<i>Notomastus</i> (LPIL)	1
G	<i>Oxyurostylis</i> (LPIL)	1	

LPIL - Lowest Practical Identification Level

\* Taxa overlap with species identified in Ross et al. 2009

P = Phylum; C = Class; O = Order; F = Family; G = Genus; S = Species

PN : 100018536

# ATKINS

Macrobenthic Organisms Collected from the Proposed Port of Gulfport Expansion Project, Gulfport  
Mississippi

Site ID	LPIL	Taxon	Number present
<b>SA 14</b>	G	<i>Paramphinome</i> (LPIL)	8
	S	<i>Paraprionospio pinnata</i>	1
	P	Nemertea (LPIL)	5
	S	<i>Sigambra tentaculata</i>	4
	S	<i>Spiochaetopterus oculatus</i>	2
	O	Decapoda (LPIL)	3
	<b>Total</b>		
<b>SA 15</b>	O	Actinaria (LPIL)	2
	C	Bivalvia (LPIL)*	1
	S	<i>Glycinde solitaria</i>	5
	F	Hesionidae	3
	G	<i>Magelona</i> (LPIL)	4
	G	<i>Notomastus</i> (LPIL)	20
	S	<i>Owenia fusiformis</i>	1
	C	Polychaeta (LPIL)	1
	P	Nemertea (LPIL)	11
	S	<i>Sigambra tentaculata</i>	9
	S	<i>Spiochaetopterus oculatus</i>	2
	F	Tellinidae (LPIL)	1
	O	Decapoda (LPIL)	1
<b>Total</b>			<b>61</b>
<b>SA 16</b>	S	<i>Acteocina canaliculata</i>	1
	S	<i>Ampelisca abdita</i>	2
	S	<i>Amphicteis floridus</i>	5
	O	Amphipoda (LPIL)	2
	S	<i>Apocorophium louisianum</i>	26
	C	Bivalvia (LPIL)*	1
	S	<i>Glycinde solitaria</i>	1
	F	Hesionidae	2
	S	<i>Leitoscoloplos fragilis</i> *	19
	S	<i>Mediomastus ambiseta</i> *	5
	S	<i>Myriochele oculata</i>	1
	S	<i>Parandalia tricuspis</i>	2
	C	Polychaeta (LPIL)	1
	S	<i>Polydora cornuta</i>	3
	S	<i>Protomystides bidentata</i>	1
	P	Nemertea (LPIL)	3
	S	<i>Streblospio benedicti</i>	7
	S	<i>Teinostoma biscaynense</i>	2
<b>Total</b>			<b>84</b>
<b>SA 17</b>	S	<i>Amphicteis floridus</i>	1
	S	<i>Cossura soyeri</i>	5

LPIL - Lowest Practical Identification Level

\* Taxa overlap with species identified in Ross et al. 2009

P = Phylum; C = Class; O = Order; F = Family; G = Genus; S = Species

PN : 100018536

# ATKINS

Macrobenthic Organisms Collected from the Proposed Port of Gulfport Expansion Project, Gulfport  
Mississippi

Site ID	LPIL	Taxon	Number present
SA 17	S	<i>Glycera americana</i>	7
	S	<i>Leitoscoloplos fragilis*</i>	9
	G	<i>Magelona</i> (LPIL)	1
	S	<i>Mediomastus ambiseta*</i>	1
	S	<i>Myriochele oculata</i>	1
	F	Mysidaceae (LPIL)	1
	G	<i>Notomastus</i> (LPIL)	14
	S	<i>Nuculana acuta</i>	1
	P	Nemertea (LPIL)	4
	S	<i>Sigambra tentaculata</i>	6
	S	<i>Spiochaetopterus oculatus</i>	1
	G	<i>Stylochus</i> (LPIL)	1
	<b>Total</b>		
SA 18	S	<i>Ampelisca abdita</i>	3
	F	Ampharetidae	4
	S	<i>Amphicteis floridus</i>	3
	O	Amphipoda (LPIL)	8
	S	<i>Apocorophium louisianum</i>	1
	S	<i>Axiothella mucosa</i>	4
	S	<i>Capitella capitata</i>	2
	S	<i>Eteone fauchaldi</i>	1
	S	<i>Glycinde solitaria</i>	15
	F	Hesionidae	1
	S	<i>Leitoscoloplos fragilis*</i>	1
	S	<i>Linga amiantus</i>	1
	S	<i>Macoma tenta</i>	44
	G	<i>Magelona</i> (LPIL)	47
	S	<i>Mediomastus ambiseta*</i>	136
	G	<i>Megalomma</i> (LPIL)	3
	F	Mysidaceae (LPIL)	7
	S	<i>Nassarius acutus*</i>	10
	G	<i>Notomastus</i> (LPIL)	10
	F	Ophiuroidea (LPIL)	1
	S	<i>Owenia fusiformis</i>	1
	G	<i>Pagurus</i> (LPIL)	1
	S	<i>Pandora trilineata</i>	2
	S	<i>Paraprionospio pinnata</i>	9
	F	Phyllodocidae (LPIL)	3
	S	<i>Pinnixa chaetopterus</i>	2
	S	<i>Podarke obscura</i>	2
	P	Nemertea (LPIL)	23
S	<i>Sigambra tentaculata</i>	19	

LPIL - Lowest Practical Identification Level

\* Taxa overlap with species identified in Ross et al. 2009

P = Phylum; C = Class; O = Order; F = Family; G = Genus; S = Species

PN : 100018536



# ATKINS

Macrobenthic Organisms Collected from the Proposed Port of Gulfport Expansion Project, Gulfport  
Mississippi

Site ID	LPIL	Taxon	Number present
SA 18	S	<i>Spiophanes bombyx</i> *	23
	S	<i>Teinostoma biscaynense</i>	1
	S	<i>Tellidora cristata</i>	1
	F	Tellinidae (LPIL)	1
	F	Terebellidae (LPIL)	3
	S	<i>Tharyx acutus</i>	8
	O	Decapoda (LPIL)	14
<b>Total</b>			<b>415</b>
SA 19	S	<i>Acteocina canaliculata</i>	1
	S	<i>Glycinde solitaria</i>	13
	S	<i>Mediomastus ambiseta</i> *	6
	S	<i>Monoculodes sp. D</i>	2
	F	Mysidacae (LPIL)	6
	P	Nematoda	1
	G	<i>Oxyurostylis</i> (LPIL)	2
	G	<i>Pagurus</i> (LPIL)	1
	P	Nemertea (LPIL)	4
	G	<i>Stylochus</i> (LPIL)	1
	S	<i>Tagelus plebeius</i>	1
<b>Total</b>			<b>38</b>

LPIL - Lowest Practical Identification Level

\* Taxa overlap with species identified in Ross et al. 2009

P = Phylum; C = Class; O = Order; F = Family; G = Genus; S = Species

PN : 100018536

## **Appendix D**

### **Water and Sediment Chemistry Data**



TABLE D1

STANDARD PARAMETERS  
GULPORT SHIP CHANNEL - 2012

Station*	Date	Time	Subs trate	Secchi Depth (ft)	Water Depth (ft)	Dissolved		pH		Salinity		Water Temp		NTU		Air Temp (°C)	Coordinates							
						Sfc	Bot	Sfc	Bot	Sfc	Bot	Sfc	Bot	Sfc	Bot		Sfc	Bot	Latitude (N)			Longitude (W)		
																			Deg.	Min.	Sec.	Deg.	Min.	Sec.
SA-01	4/3/2012	0738	2	1.5	8.4	7.73	6.42	7.08	7.02	7.11	7.21	22.0	22.1	8.03	8.14	22.5	30	15	43.2	89	15	34.2		
SA-02	4/3/2012	1233	3	2	7.5	7.70	6.88	7.70	7.54	8.88	9.13	22.6	22.5	9.89	10.16	26.9	30	19	49.9	89	11	27.5		
SA-03	4/3/2012	0811	2	2.5	12.0	7.96	5.67	7.52	7.54	10.78	13.68	21.3	21.5	11.82	14.83	23.2	30	15	43.2	89	11	27.5		
SA-04	4/3/2012	0841	3	3.0	17.0	7.82	3.73	7.67	7.44	14.06	19.64	21.5	21.3	15.09	20.58	22.2	30	11	36.5	89	7	20.8		
SA-05	4/3/2012	1316	1	1.5	9.4	9.39	4.63	7.97	7.43	10.54	11.73	23.0	22.2	11.62	12.78	27.2	30	19	49.9	89	7	20.8		
SA-06	4/3/2012	1206	1	3.5	13.4	7.50	4.11	7.74	7.36	14.18	19.31	21.8	21.2	15.20	20.16	26.8	30	15	43.2	89	7	20.8		
SA-07	4/3/2012	0911	2	3.0	11.5	7.51	5.02	7.78	7.58	17.30	20.67	21.8	21.6	18.23	15.26	22.4	30	11	36.5	89	3	14.1		
SA-08	4/3/2012	1333	1	2.0	10.5	8.61	2.99	7.88	7.31	12.94	17.29	22.7	21.4	13.99	18.20	26.8	30	19	49.9	89	3	14.1		
SA-09	4/3/2012	1148	3	3.5	16.5	7.64	2.43	7.82	7.72	16.96	25.32	22.4	20.3	17.92	25.78	26.3	30	15	43.2	89	3	14.1		
SA-10	4/3/2012	0937	2	3.0	22.0	7.45	1.08	7.81	7.31	19.37	32.42	21.6	18.7	20.21	32.16	22.8	30	11	36.5	89	3	14.1		
SA-11	4/3/2012	1351	1	2.0	11.4	8.80	9.21	7.91	7.36	12.08	17.30	23.4	21.8	13.17	18.22	26.5	30	19	49.9	88	59	7.4		
SA-12	4/3/2012	1129	1	3.5	16.7	7.74	1.42	7.83	7.27	16.79	29.83	21.9	19.6	17.74	29.66	25.9	30	15	43.2	88	59	7.4		
SA-13	4/3/2012	1100	3	4.0	23.0	7.47	4.49	7.95	7.46	19.79	33.93	21.7	18.4	20.62	33.53	25.5	30	11	36.5	88	59	7.4		
SA-14	4/3/2012	1409	1	2.5	11.4	8.15	3.83	7.85	7.52	14.57	16.02	22.3	22.0	15.59	16.91	26.8	30	19	49.9	88	55	0.7		
SA-15	4/3/2012	1114	1	3.5	16.0	6.46	2.26	7.84	7.47	16.08	21.19	21.9	21.4	17.06	22.07	25.7	30	15	43.2	88	55	0.7		
SA-16	4/3/2012	1502	3	1.5	3.6	8.21	7.39	7.81	7.55	4.12	4.22	23.4	23.1	4.86	4.96	26.8	30	23	56.6	88	50	54.0		
SA-17	4/3/2012	1426	2	1.5	10.0	9.42	7.58	7.99	7.69	10.00	12.42	22.7	22.3	11.04	13.05	27.0	30	19	49.9	88	50	54.0		
SA-18	4/3/2012	1057	3	2.0	18.0	7.57	3.99	7.87	7.55	13.90	33.39	21.7	18.6	14.90	33.02	25.6	30	15	43.2	89	6	31.3		
SA-19	4/3/2012	1533	3	2.0	5.4	6.76	7.28	7.85	7.62	11.14	11.68	24.6	22.9	12.24	15.46	26.9	30	22	56.1	88	58	20.9		
PA-01	4/5/2012	1009	2	1.5	6.4	7.27	6.16	7.36	7.28	11.73	12.29	21.2	21.4	12.78	13.37	24.6	30	21	7.0	89	6	48.8		
PA-02	4/5/2012	1204	1	2.0	9.5	7.89	2.77	7.60	7.13	11.24	19.01	21.6	20.8	12.28	20.28	25.2	30	21	29.2	89	4	53.3		
PA-03	4/5/2012	1155	1	1.5	9.5	8.23	7.20	7.58	7.48	11.10	11.23	21.6	21.5	12.14	12.26	25.0	30	21	29.2	89	4	4.2		
PA-04	4/5/2012	1029	1	2.5	9.0	7.85	6.75	7.52	7.45	11.70	12.98	21.1	21.5	12.74	14.20	24.7	30	20	39.5	89	6	31.1		
PA-05	4/5/2012	1033	3	1.5	5.8	7.69	7.50	7.59	7.57	11.80	11.96	21.2	21.2	12.86	13.00	24.7	30	20	39.5	89	5	42.3		
PA-06	4/5/2012	1143	1	1.5	9.3	7.44	7.09	7.61	7.52	11.46	12.30	21.4	21.4	12.51	13.39	25.5	30	20	39.5	89	4	4.2		
PA-07	4/5/2012	1056	1	1.5	11.0	8.07	6.74	7.61	7.50	11.61	14.28	21.2	21.6	12.66	15.44	25.4	30	19	50.4	89	5	42.7		
PA-08	4/5/2012	1112	1	1.5	11.4	8.01	6.96	7.60	7.53	11.71	14.58	21.2	21.4	12.78	15.97	25.5	30	19	50.8	89	4	53.3		
PA-10	4/5/2012	1124	1	1.5	10.4	7.91	7.45	7.55	7.52	11.92	12.99	21.3	21.3	12.97	14.23	25.7	30	19	50.6	89	4	4.0		
PE-11-A	4/5/2012	1259	1	2.0	31.0	8.30	0.83	7.72	7.03	11.68	30.82	21.6	18.8	12.78	30.71	25.6	30	21	19.3	89	12	12.6		
PE-11-B	4/5/2012	1221	1	2.0	8.0	7.78	2.93	7.59	7.17	11.39	18.32	21.8	20.7	12.44	19.00	24.7	30	21	19.3	88	5	7.8		
PE-11-C	4/5/2012	1233	1	2.0	13.0	8.54	6.92	7.72	7.62	11.51	12.55	21.6	20.3	12.55	20.55	24.8	30	21	14.4	89	5	7.8		
PM-11-A	4/5/2012	1904	1	1.5	9.8	8.28	3.05	7.81	7.28	12.88	24.30	21.8	20.0	13.91	24.80	26.8	30	20	59.5	89	5	22.9		
PM-11-B	4/5/2012	1851	1	2.0	9.0	8.09	2.58	7.69	7.28	12.71	23.15	22.1	20.2	13.74	21.78	27.3	30	20	49.9	89	5	32.7		
PM-11-C	4/5/2012	1830	1	1.5	11.2	8.07	1.82	7.80	7.23	13.08	26.75	21.9	19.7	14.14	26.97	27.8	30	20	49.7	89	5	22.9		
PM-11-D	4/5/2012	1731	3	1.5	6.2	7.61	9.01	7.94	7.89	11.94	11.95	22.3	22.3	13.00	13.00	28.8	30	20	39.9	89	5	22.8		
PM-11-E	4/5/2012	1752	3	2.0	7.8	7.88	7.30	8.02	7.70	11.77	13.31	22.4	22.0	12.82	14.62	28.7	30	20	39.7	89	5	13.1		
PM-11-F	4/5/2012	1805	1	1.5	8.2	9.22	6.98	7.93	7.60	11.74	14.23	22.2	21.8	12.79	15.42	28.3	30	20	39.6	89	5	3.7		
PM-11-G	4/5/2012	1620	1	2.0	8.8	8.09	6.05	7.87	7.52	11.69	13.52	22.1	21.6	12.75	14.92	28.9	30	20	30.2	89	5	22.8		
PM-11-H	4/5/2012	1641	1	2.0	8.8	8.92	3.47	7.78	7.46	11.79	19.41	22.1	20.7	12.83	20.29	28.9	30	20	30.1	89	5	12.9		
PM-11-I	4/5/2012	1657	1	2.0	7.2	7.70	8.83	7.81	7.81	11.79	11.74	22.2	22.2	12.85	12.81	28.9	30	20	30.3	89	5	3.2		
PN-11-A	4/5/2012	1315	1	1.5	15.3	9.41	3.45	7.95	7.32	11.63	27.13	21.6	19.6	12.68	26.57	25.9	30	21	34.0	89	5	37.9		
PN-11-B	4/5/2012	1325	3	2.0	7.6	2.44	6.17	7.98	7.52	11.71	15.62	21.8	20.9	12.75	17.01	25.9	30	21	38.8	89	5	37.6		
TB-11-A	4/5/2012	1352	1	2.0	16.0	7.70	5.77	7.91	7.43	12.03	15.95	22.1	20.0	13.09	16.98	25.9	30	20	49.5	88	5	3.1		
TB-11-B	4/5/2012	1423	1	2.0	10.7	7.75	2.60	7.81	7.24	12.21	23.43	21.8	20.2	13.36	23.92	26.0	30	20	49.7	89	4	53.0		
TB-11-C	4/5/2012	1453	1	2.0	9.5	8.57	3.24	7.82	7.24	11.90	20.96	22.0	20.5	12.95	21.05	26.8	30	20	39.9	89	4	53.4		
TB-11-D	4/5/2012	1511	1	2.0	10.5	8.86	4.10	7.85	7.31	11.86	21.28	22.1	20.4	12.92	5.27	26.7	30	20	39.7	89	4	43.2		
TB-11-E	4/5/2012	1527	1	2.0	31.4	8.83	0.83	7.81	7.24	11.79	28.26	22.1	18.8	12.66	28.44	26.3	30	20	29.8	89	4	33.5		
TB-11-F	4/5/2012	1541	1	2.0	9.2	8.64	3.76	7.85	7.27	11.47	19.60	22.2	20.7	12.51	20.40	27.1	30	20	30.4	89	4	44.6		

NTU = Nephelometric Turbidity Unit

TABLE D2

## PARAMETERS DETERMINED BY CHEMICAL ANALYSIS

<u>METALS</u>	
Antimony	Lead
Arsenic	Mercury
Beryllium	Nickel
Cadmium	Selenium
Chromium, Total	Silver
Chromium, Trivalent	Thallium
Chromium, Hexavalent	Zinc
Copper	
<u>PESTICIDES AND PCBs</u>	
Aldrin	Dieldrin
Alpha-BHC	Endosulfan I
Beta-BHC	Endosulfan II
Gamma-BHC (Lindane)	Endosulfan sulfate
Delta-BHC	Endrin
Chlordane	Endrin aldehyde
Alpha-Chlordane	Heptachlor
Gamma-Chlordane	Heptachlor epoxide
4,4'-DDD	Toxaphene
4,4'-DDE	Total PCBs
4,4'-DDT	
<u>SEMIVOLATILES</u>	
Acenaphthene	Dimethyl phthalate
Acenaphthylene	Di-n-butyl phthalate
Anthracene	2,4-Dinitrotoluene
Benzidine	2,6-Dinitrotoluene
Benzo(a)anthracene	Di-n-octyl phthalate
Benzo(a)pyrene	1,2-Diphenylhydrazine
Benzo(ghi)perylene	Fluoranthene
Benzo(b&k)fluoranthene	Fluorene
Bis(2-chloroethoxy)methane	Hexachlorobenzene
Bis(2-chloroethyl)ether	Hexachlorobutadiene
Bis(2-chloroisopropyl)ether	Hexachlorocyclopentadiene
Bis(2-ethylhexyl)phthalate	Hexachloroethane
4-Bromophenyl phenyl ether	Indeno(123-CD)pyrene
Butyl benzyl phthalate	Isophorone
4-chloro-3-methylphenol	2-Methyl-4,6-dinitrophenol (4,6-dinitro-o-cresol)
2-Chloronaphthalene	Naphthalene
2-Chlorophenol	Nitrobenzene
4-Chlorophenyl phenyl ether	2-Nitrophenol
Chrysene	4-Nitrophenol
Dibenzo(ah)anthracene	N-nitrosodimethylamine
1,2-Dichlorobenzene	N-nitrosodi-n-propylamine
1,3-Dichlorobenzene	N-nitrosodiphenylamine
1,4-Dichlorobenzene	Phenanthrene
3,3'-Dichlorobenzidine	Phenol
2,4-Dichlorophenol	Pentachlorophenol
2,4-Dinitrophenol	Pryene
Diethyl phthalate	1,2,4-Trichlorobenzene
2,4-Dimethylphenol	2,4,6-Trichlorophenol

TABLE D2 (Concluded)

## PARAMETERS DETERMINED BY CHEMICAL ANALYSIS

CONVENTIONAL PARAMETERS

Ammonia	Total Petroleum Hydrocarbons
Cyanide	Lipids**
Total Organic Carbon	% Solids*

## DIOXIN/FURAN CONGENERS

2,3,7,8 - Tetrachloro Dibenzo- <i>p</i> -Dioxin	
1,2,3,7,8 - Pentachloro Dibenzo- <i>p</i> -Dioxin	1,2,3,7,8,9 - Hexachloro Dibenzo- <i>p</i> -Dioxin
1,2,3,4,7,8 - Hexachloro Dibenzo- <i>p</i> -Dioxin	1,2,3,4,6,7,8 - Heptachloro Dibenzo- <i>p</i> -Dioxin
1,2,3,6,7,8 - Hexachloro Dibenzo- <i>p</i> -Dioxin	Octachloro Dibenzo- <i>p</i> -Dioxin
2,3,7,8 - Tetrachloro Dibenzo- <i>p</i> -Furan	2,3,4,6,7,8 - Hexachloro Dibenzo- <i>p</i> -Furan
1,2,3,7,8 - Pentachloro Dibenzo- <i>p</i> -Furan	1,2,3,7,8,9 - Hexachloro Dibenzo- <i>p</i> -Furan
2,3,4,7,8 - Pentachloro Dibenzo- <i>p</i> -Furan	1,2,3,4,6,7,8 - Heptachloro Dibenzo- <i>p</i> -Furan
1,2,3,4,7,8 - Hexachloro Dibenzo- <i>p</i> -Furan	1,2,3,4,7,8,9 - Heptachloro Dibenzo- <i>p</i> -Furan
1,2,3,6,7,8 - Hexachloro Dibenzo- <i>p</i> -Furan	Octachloro Dibenzo- <i>p</i> -Furan

---

\* sediment only

\*\* tissue only

TABLE D3

CONCENTRATIONS OF DETECTED COMPOUNDS (ug/L)  
WATER  
GULPORT SHIP CHANNEL - 2012

Date Sampled: April 05, 2012

Parameter	WQC		WQS		Detection Limit	PE-11- (A,B,C)	PM-11- (A,B,C)	PM-11-3- (D,E,F)	PM-11-3 (G,H,I)	PN-11- (A,B)	TB-11- (A,B,C)	TB-11- (D,E,F)	TB-11- (D,E,F) Dup	Field Blank
	CMC	CCC	Acute	Chronic										
Arsenic	69	36	69	36	1.00	1.50	2.90	BDL	BDL	BDL	BDL	BDL	1.20	BDL
Copper	4.8	3.1	4.8	3.1	1.00	2.50	7.26	BDL	2.80	4.50	1.80	3.20	2.10	BDL
Nickel	74	8.2	75	8.3	1.00	BDL	BDL	BDL	BDL	BDL	BDL	BDL	BDL	BDL
Selenium	290	71	290	71	2.00	BDL	2.56	2.30	1.29 J	2.40	1.90 J	0.46 J	0.60 J	BDL
Zinc	90	81	90.0	81.0	1.00	BDL	BDL	BDL	BDL	BDL	BDL	BDL	BDL	BDL
Ammonia*	11.8	1.75	11.8	1.75	0.03	0.34	0.18	0.13	0.12	0.17	0.10	0.12	0.12	N/A
TOC*	N/A	N/A	N/A	N/A	0.10	5.15	5.04	5.49	5.39	5.61	5.15	5.31	4.93	N/A

Dup = Duplicate Sample

BDL = Below Detection Limits

\* mg/L = micrograms per liter

J Compound detected value below Quantitation Limits

TABLE D4

CONCENTRATIONS OF DETECTED COMPOUNDS (ug/L)  
ELUTRIATE  
GULPORT SHIP CHANNEL - 2012

Date Sampled: April 05, 2012

Parameter	WQC		WQS		Detection Limit	PE-11- (A,B,C)	PM-11- (A,B,C)	PM-11-3- (D,E,F)	PM-11-3 (G,H,I)	PN-11- (A,B)	TB-11- (A,B,C)	TB-11- (D,E,F)	TB-11- (D,E,F) Dup
	CMC	CCC	Acute	Chronic									
Arsenic	69	36	69	36	1.00	2.30	2.60	1.90	3.00	2.30	2.20	2.60	2.60
Copper	4.8	3.1	4.8	3.1	1.00	BDL	BDL	BDL	BDL	BDL	BDL	BDL	BDL
Nickel	74	8.2	75	8.3	1.00	1.40	BDL	BDL	BDL	BDL	BDL	BDL	BDL
Selenium	290	71	290	71	2.00	BDL	BDL	BDL	BDL	BDL	BDL	BDL	BDL
Zinc	90	81	90.0	81.0	1.00	BDL	BDL	BDL	24.9	BDL	BDL	BDL	BDL
Ammonia*	11.8	1.75	11.8	1.75	0.03	0.14	0.16	0.13	0.14	0.12	0.13	0.13	0.13
TOC*	N/A	N/A	N/A	N/A	0.10	4.40	4.50	4.11	4.53	4.59	4.59	5.21	5.45

Dup = Duplicate Sample

BDL = Below Detection Limits

\* mg/L

J Compound detected value below Quantitation Limits



TABLE D5A

CONCENTRATIONS OF DETECTED COMPOUNDS (dry weight)  
SEDIMENT  
GULPORT SHIP CHANNEL - 2012

Date Sampled: April 05, 2012

Parameter	Units	Detection Limit	NOAA ERL	PE-11- (A,B,C)	PM-11-3- (A,B,C)	PM-11-3- (D,E,F)	PM-11-3- (G,H,I)	PN-11- (A,B)	TB-11- (A,B,C)	TB-11- (D,E,F)	TB-11- (D,E,F) Dup								
Arsenic	mg/kg	0.30	8.2	5.13	6.35	2.39	3.19	5.85	6.39	<b>9.68</b>	<b>11.0</b>								
Beryllium	mg/kg	1.00	N/A	0.76	J	1.17	0.37	J	0.40	J	1.12	1.11	1.81	1.49					
Chromium, Total	mg/kg	1.00	81.0	14.8	16.5	5.31	7.25	13.5	13.9	19.7	20.2								
Chromium III	mg/kg	1.00	N/A	14.8	16.5	5.31	7.25	13.5	13.9	19.7	20.2								
Copper	mg/kg	1.00	34.0	9.92	7.13	2.31	2.68	11.2	6.35	8.84	8.88								
Lead	mg/kg	0.30	46.7	15.0	13.2	5.01	6.14	17.4	13.6	18.1	17.8								
Mercury	mg/kg	0.20	0.15	0.07	J	BDL	BDL	BDL	0.06	J	BDL	0.05	J	0.09	J				
Nickel	mg/kg	0.50	20.9	8.70	9.28	3.44	4.19	7.94	7.86	11.9	11.4								
Selenium	mg/kg	0.50	N/A	0.37	J	0.23	J	0.21	J	0.22	J	0.70	0.29	J	0.26	J	0.53		
Silver	mg/kg	0.20	1.0	0.07	J	0.06	J	BDL	BDL	0.06	J	0.07	J	0.08	J	0.09	J		
Thallium	mg/kg	0.20	N/A	0.14	J	0.15	J	0.06	J	BDL	J	0.17	J	0.13	J	0.18	J	0.18	J
Zinc	mg/kg	2.00	150	47.2	40.3	13.6	16.7	52.3	37.5	53.7	53.1								
Naphthalene	ug/kg	20.0	160	41.8	BDL	BDL	BDL	BDL	BDL	BDL	BDL	BDL							
Phenanthrene	ug/kg	20.0	240	198	BDL	BDL	BDL	BDL	BDL	BDL	BDL	BDL							
Anthracene	ug/kg	20.0	85.3	56.1	BDL	BDL	BDL	BDL	BDL	BDL	BDL	BDL							
Fluoranthene	ug/kg	20.0	600	273	76.9	39.8	BDL	54.3	43.1	BDL	57.8								
Pyrene	ug/kg	20.0	665	256	83.3	41.4	BDL	63.1	BDL	BDL	66.0								
Chrysene	ug/kg	20.0	384	193	110	45.7	BDL	32.5	BDL	BDL	BDL								
Benzo(a)Anthracene	ug/kg	20.0	261	185	86.4	34.9	BDL	28.4	BDL	BDL	BDL								
Bis (2-ethylhexyl) phthalate	ug/kg	50.0	N/A	BDL	125	BDL	BDL	BDL	BDL	BDL	BDL	BDL							
Benzo(b)Fluoranthene	ug/kg	20.0	N/A	236	139	44.9	BDL	27.7	BDL	BDL	BDL								
Benzo(k)Fluoranthene	ug/kg	20.0	N/A	164	118	45.2	BDL	41.0	BDL	BDL	BDL								
Benzo(a)Pyrene	ug/kg	20.0	430	173	92.0	38.6	BDL	29.6	BDL	BDL	BDL								
Indeno(123-cd)Pyrene	ug/kg	20.0	N/A	60.4	34.9	BDL	BDL	BDL	BDL	BDL	BDL								
Benzo(ghi)Perylenene	ug/kg	20.0	N/A	70.3	47.3	22.9	BDL	22.6	BDL	BDL	BDL								
Ammonia	mg/kg	0.10	N/A	133	98.6	35.8	46.5	63.7	119	202	169								
TOC	%	0.10	N/A	1.94	1.31	0.41	0.65	1.21	1.82	2.20	2.72								
Percent Solids	%	N/A	N/A	43.6	47.8	70.6	64.5	52.5	45.0	38.0	34.2								

TABLE D5A

CONCENTRATIONS OF DETECTED COMPOUNDS (dry weight)  
SEDIMENT  
GULPORT SHIP CHANNEL - 2012

Parameter	Units	Detection Limit	NOAA ERL	PE-11- (A,B,C)	PM-11- (A,B,C)	PM-11-3- (D,E,F)	PM-11-3 (G,H,I)	PN-11- (A,B)	TB-11- (A,B,C)	TB-11- (D,E,F)
<b>UN-NORMALIZED DATA as TEQs</b>										
2,3,7,8-TCDD	pg/g		N/A	0.33 QJ	0.56 Q	0.54 J	0.38 J	0.15 QJ	0.14 QJ	0.14 QJ
1,2,3,7,8-PeCDD	pg/g		N/A	2.3 J	1.8 J	1.3 J	0.97 J	0.84 J	0.43 QJ	0.43 QJ
1,2,3,4,7,8-HxCDD	pg/g		N/A	0.55 B	0.45 B	0.24 BJ	0.16 BJ	0.16 BJ	0.13 BJ	0.13 BJ
1,2,3,6,7,8-HxCDD	pg/g		N/A	1.1 B	0.76 QBJ	0.37 B	0.25 BJ	0.26 BJ	0.21 BJ	0.21 BJ
1,2,3,7,8,9-HxCDD	pg/g		N/A	2.90 B	2.6 CB	0.93 CB	0.62 CB	0.63 CB	0.50 CB	0.50 CB
1,2,3,4,6,7,8-HpCDD	pg/g		N/A	4.1 B	2.9 B	1.2 B	0.88 B	0.85 B	0.72 B	0.72 B
OCDD	pg/g		N/A	1.8 BE	1 BE	0.60 B	0.45 B	0.45 B	0.39 B	0.39 B
2,3,7,8-TCDF	pg/g		N/A	0.053 J	0.016 QJ	0.13 Q	0.12 Q	0.13 Q	0.068 Q	0.068 Q
1,2,3,7,8-PeCDF	pg/g		N/A	0.010 QBJ	0.0039 QBJ	0.017 QBJ	0.013 BJ	0.011 QBJ	0.0084 BJ	0.0084 BJ
2,3,4,7,8-PeCDF	pg/g		N/A	0.16 QBJ	0.036 QBJ	0.15 QBJ	0.13 BJ	0.087 QBJ	0.081 BJ	0.081 BJ
1,2,3,4,7,8-HxCDF	pg/g		N/A	0.15 BJ	0.02 QBJ	0.11 CBJ	0.062 QBJ	0.064 QBJ	0.053 CBJ	0.053 CBJ
1,2,3,6,7,8-HxCDF	pg/g		N/A	0.13 QBJ	0.035 BJ	0.069 BJ	0.051 QBJ	0.045 BJ	0.035 QBJ	0.035 QBJ
2,3,4,6,7,8-HxCDF	pg/g		N/A	0.079 BJ	0.016 QBJ	0.038 BJ	0.027 BJ	0.023 BJ	0.022 BJ	0.022 BJ
1,2,3,7,8,9-HxCDF	pg/g		N/A	0.019 QBJ	0.0099 BJ	0.015 QBJ	0.016 BJ	0.014 BJ	0.026 QBJ	0.026 QBJ
1,2,3,4,6,7,8-HpCDF	pg/g		N/A	0.16 B	0.032 B	0.073 B	0.046 B	0.043 B	0.033 QB	0.033 QB
1,2,3,4,7,8,9-HpCDF	pg/g		N/A	0.011 BJ	0.0028 QBJ	0.0093 BJ	0.0077 QBJ	0.0069 BJ	0.0029 QBJ	0.0029 QBJ
OCDF	pg/g		N/A	0.0033 B	0.0006 QBJ	0.0014 BJ	0.00072 BJ	0.00048 BJ	0.00084 BJ	0.00084 BJ
Total TEQ	pg/g		N/A	14	10	5.8	4.2	3.8	2.9	2.9
<b>NORMALIZED DATA as TEQs per 1% Organic Carbon</b>										
2,3,7,8-TCDD	pg/g		N/A	17.0	42.7	132	58.5	12.4	7.69	6.36
1,2,3,7,8-PeCDD	pg/g		N/A	119	137	317	149	69.4	23.6	19.5
1,2,3,4,7,8-HxCDD	pg/g		N/A	28.4	34.4	58.5	24.6	13.2	7.14	5.91
1,2,3,6,7,8-HxCDD	pg/g		N/A	56.7	58.0	90.2	38.5	21.5	11.5	9.55
1,2,3,7,8,9-HxCDD	pg/g		N/A	149.5	198.5	226.8	95.4	52.1	27.5	22.7
1,2,3,4,6,7,8-HpCDD	pg/g		N/A	211.3	221.4	292.7	135.4	70.2	39.6	32.7
OCDD	pg/g		N/A	92.8	76.3	146.3	69.2	37.2	21.4	17.7
2,3,7,8-TCDF	pg/g		N/A	2.73	1.22	31.7	18.5	10.7	3.74	3.09
1,2,3,7,8-PeCDF	pg/g		N/A	0.52	0.30	4.15	2.00	0.91	0.46	0.38
2,3,4,7,8-PeCDF	pg/g		N/A	8.25	2.75	36.6	20.0	7.19	4.45	3.68
1,2,3,4,7,8-HxCDF	pg/g		N/A	7.73	1.83	26.8	9.54	5.29	2.91	2.41
1,2,3,6,7,8-HxCDF	pg/g		N/A	6.70	2.67	16.8	7.85	3.72	1.92	1.59
2,3,4,6,7,8-HxCDF	pg/g		N/A	4.07	1.22	9.27	4.15	1.90	1.21	1.00
1,2,3,7,8,9-HxCDF	pg/g		N/A	0.98	0.76	3.66	2.46	1.16	1.43	1.18
1,2,3,4,6,7,8-HpCDF	pg/g		N/A	8.25	2.44	17.8	7.08	3.55	1.81	1.50
1,2,3,4,7,8,9-HpCDF	pg/g		N/A	0.57	0.21	2.27	1.18	0.57	0.16	0.13
OCDF	pg/g		N/A	0.17	0.05	0.34	0.11	0.04	0.05	0.04
Total TEQ	pg/g		N/A	722	763	1415	646	314	159	132

Dup = Duplicate Sample

BDL = Below Detection Limit

N/A = Not Applicable

J Estimated result. Analyte detected below Quantitation Limits

TABLE D5A

CONCENTRATIONS OF DETECTED COMPOUNDS (dry weight)  
SEDIMENT  
GULPORT SHIP CHANNEL - 2012

Q Estimated maximum possible concentration.

C Co-eluting isomer

B Method blank contamination. The associated method blank contains the target analyte at a reportable level.

E Estimated result. Result concentration exceeds the calibration range.

S Ion suppression.

mg/kg = milligrams per kilograms

µg/kg = micrograms per kilograms

TABLE D5B  
GRAIN SIZE DATA  
GULFPORT SHIP CHANNEL - 2012

Date Sampled: April 03 & 05, 2012

Parameter	Units	Detection Limit	PE-11-			PM-11-								
			A	B	C	3A	3B	3C	3D	3E	3F	3G	3H	3I
Gravel	%	N/A	1.6	0.0	11.0	0.3	0.0	0.0	1.4	0.0	0.0	0.0	0.0	0.0
Sand	%	N/A	33.3	39.8	21.0	37.3	19.0	31.6	93.0	97.7	32.0	98.5	33.6	64.1
Silt	%	N/A	28.8	33.1	37.4	28.3	34.1	31.1	5.0	0.5	31.7	0.3	33.0	17.2
Clay	%	N/A	36.3	27.1	30.6	34.1	46.9	37.3	0.6	1.8	36.3	1.2	33.4	18.7
D50	mm	N/A	0.0140	0.0466	0.0417	0.0422	0.0074	0.0199	0.419	0.297	0.036	0.269	0.0458	0.236

Parameter	Units	Detection Limit	PN-11-		TB-11-					SA-				
			A	B	A	B	C	D	E	F	01	02	03	04
Gravel	%	N/A	0.0	2.7	0.0	0.0	1.8	0.0	0.0	0.9	0.0	0.0	0.0	3.9
Sand	%	N/A	59.3	78.1	2.5	80.9	56.2	15.8	5.4	74.7	98.0	78.2	7.0	46.0
Silt	%	N/A	19.8	12.9	55.7	12.3	7.9	32.2	46.6	5.4	1.4	20.0	53.9	26.6
Clay	%	N/A	20.9	6.3	41.8	6.8	34.1	52.0	48.0	19.0	0.6	1.8	39.1	23.5
D50	mm	N/A	0.153	0.221	0.0105	0.251	0.199	0.0041	0.0060	0.225	0.489	0.192	0.0151	0.0748

Parameter	Units	Detection Limit	SA-											
			05	06	07	08	09	10	11	12	13	14	15	16
Gravel	%	N/A	0.0	0.0	0.0	0.0	0.3	0.0	0.0	0.0	0.0	0.0	0.0	0.0
Sand	%	N/A	13.7	9.2	67.5	20.4	80.9	47.7	33.7	39.7	66.9	42.5	19.2	96.1
Silt	%	N/A	51.7	42.9	21.4	35.4	9.4	40.3	38.6	47.6	18.2	43.9	33.2	2.0
Clay	%	N/A	34.6	47.9	11.1	44.2	9.4	12.0	27.7	12.7	14.9	13.6	47.6	1.9
D50	mm	N/A	0.0307	0.0075	0.149	0.0209	0.224	0.0723	0.0522	0.0640	0.225	0.0620	0.0068	0.182

Parameter	Units	Detection Limit	SA-						PA-				
			17	18	01	02	03	04	05	06	07	08	10
Gravel	%	N/A	0.9	1.2	0.0	1.5	0.0	0.0	0.3	0.0	0.0	0.0	0.0
Sand	%	N/A	15.8	87.9	93.6	61.6	26.8	43.7	96.0	48.2	10.8	26.4	51.8
Silt	%	N/A	33.5	2.3	5.8	19.4	41.2	34.3	3.7	26.9	43.9	40.2	23.1
Clay	%	N/A	49.8	8.6	0.6	17.5	32.0	22.0	0.0	24.9	45.3	33.4	25.1
D50	mm	N/A	0.0067	0.222	0.312	0.171	0.0382	0.0602	0.337	0.0675	0.0084	0.0386	0.0838

mm = millimeter



## **Appendix E**

### **Water Quality Data**



**WATER QUALITY DATA**

Project: **Gulfport Mississippi Expansion - Benthic Habitat Assessment**

Project Number 100018536

Date(s) Collected: April 3 & 5, 2012 Tide, MLT April 3 - 5:05 @ -0.28'  
April 5 - 4:53 @ -0.79 / 18:00 @ -0.27

Wind Direction: April 3 - East Southeast Wind Speed: April 3 - 10 to 15 mph  
April 5 - West Southwest April 5 - 15 to 20 mph

Weather and Water Conditions: April 3 - Clear skys and smooth seas  
April 5 - Over cast and 1 foot seas

Sample Number	SA*	SA*	SA*	SA*	SA*	SA*	SA*	SA*	SA*
	01	02	03	04	05	06	07	08	09
Water Depth (Ft.)	8.4	7.5	12.0	17.0	9.4	13.4	11.5	10.5	16.5
DO (mg/L)	7.73	7.70	7.96	7.82	9.39	7.50	7.51	8.61	7.64
	6.42	6.88	5.67	3.73	4.63	4.11	5.02	2.99	2.43
pH	7.08	7.70	7.52	7.67	7.97	7.74	7.78	7.88	7.82
	7.02	7.54	7.54	7.44	7.43	7.36	7.58	7.31	7.72
Salinity (psu)	7.11	8.88	10.78	14.06	10.54	14.18	17.30	12.94	16.96
	7.21	9.13	13.68	19.64	11.73	19.31	20.67	17.29	25.32
Water Temp. (°C)	22.04	22.57	21.34	21.51	23.03	21.81	21.81	22.71	22.36
	22.14	22.46	21.5	21.25	22.19	21.19	21.62	21.40	20.28
NTU	8.03	9.89	11.82	15.09	11.62	15.20	18.23	13.99	17.92
	8.14	10.16	14.83	20.58	12.78	20.16	15.26	18.20	25.78
Air Temp. (°C)	22.5	26.9	23.2	22.2	27.2	26.8	22.4	26.8	26.3
Lat.	N30 15 43.2	N30 19 49.9	N30 15 43.2	N30 11 36.5	N30 19 49.9	N30 15 43.2	N30 11 36.5	N30 19 49.9	N30 15 43.2
Long.	W89 15 34.2	W89 11 27.5	W89 11 27.5	W89 07 20.8	W89 07 20.8	W89 07 20.8	W89 03 14.1	W89 03 14.1	W89 03 14.1
Substrata	2	3	2	3	1	1	2	1	3
Secchi Depth (ft)	1.5	2.0	2.5	3.0	1.5	3.5	3.0	2.0	3.5
Time	7:38	12:33	8:11	8:41	13:16	12:06	9:11	13:33	11:48
Comment	4/3/2012	4/3/2012	4/3/2012	4/3/2012	4/3/2012	4/3/2012	4/3/2012	4/3/2012	4/3/2012

REMARKS \* Olny Grain Size and Sediment was collected



**WATER QUALITY DATA**

Project: **Gulfport Mississippi Expansion - Benthic Habitat Assessment**

Project Number 100018536

Date(s) Collected: April 3 & 5, 2012 Tide, MLT April 3 - 5:05 @ -0.28'  
April 5 - 4:53 @ -0.79 / 18:00 @ -0.27

Wind Direction: April 3 - East Southeast Wind Speed: April 3 - 10 to 15 mph  
April 5 - West Southwest April 5 - 15 to 20 mph

Weather and Water Conditions: April 3 - Clear skys and smooth seas  
April 5 - Over cast and 1 foot seas

Sample Number	SA*	SA*	SA*	SA*	SA*	SA*	SA*	SA*	SA*
	10	11	12	13	14	15	16	17	18
Water Depth (Ft.)	22.0	11.4	16.7	23.0	11.4	16.0	3.6	10.0	18.0
DO (mg/L)	7.45	8.80	7.74	7.47	8.15	6.46	8.21	9.42	7.57
	1.08	9.21	1.42	4.49	3.83	2.26	7.39	7.58	3.99
pH	7.81	7.91	7.83	7.95	7.85	7.84	7.81	7.99	7.87
	7.31	7.36	7.27	7.46	7.52	7.47	7.55	7.69	7.55
Salinity (psu)	19.37	12.08	16.79	19.79	14.57	16.08	4.12	10.0	13.90
	32.42	17.30	29.83	33.93	16.02	21.19	4.22	12.42	33.39
Water Temp. (°C)	21.57	23.38	21.87	21.66	22.31	21.93	23.38	22.73	21.73
	18.65	21.77	19.61	18.35	22.04	21.41	23.12	22.32	18.59
NTU	20.21	13.17	17.74	20.62	15.59	17.06	4.86	11.04	14.90
	32.16	18.22	29.66	33.53	16.91	22.07	4.96	13.05	33.02
Air Temp. (°C)	22.8	26.5	25.9	25.5	26.8	25.7	26.8	27.0	25.6
Lat.	N30 11 36.5	N30 19 49.9	N30 15 43.2	N30 11 36.5	N30 19 49.9	N30 15 43.2	N30 23 56.6	N30 19 49.9	N30 15 43.2
Long.	W89 03 14.1	W88 59 07.4	W88 59 07.4	W88 59 07.4	W88 55 00.7	W88 55 00.7	W88 50 54.0	W88 50 54.0	W89 06 31.3
Substrata	2	1	1	3	1	1	3	2	3
Secchi Depth (ft)	5.0	2.0	3.5	4.0	2.5	3.5	1.5	1.5	2.0
Time	9:37	13:51	11:29	11:00	14:09	11:14	15:02	14:26	10:57
Comment	4/3/2012	4/3/2012	4/3/2012	4/3/2012	4/3/2012	4/3/2012	4/3/2012	4/3/2012	4/3/2012

REMARKS \* Olmy Grain Size and Sediment was collected

**WATER QUALITY DATA**

Project: **Gulfport Mississippi Expansion - Benthic Habitat Assessment**

Project Number 100018536

Date(s) Collected: April 3 & 5, 2012 Tide, MLT April 3 - 5:05 @ -0.28'  
April 5 - 4:53 @ -0.79 / 18:00 @ -0.27

Wind Direction: April 3 - East Southeast Wind Speed: April 3 - 10 to 15 mph  
April 5 - West Southwest April 5 - 15 to 20 mph

Weather and Water Conditions: April 3 - Clear skys and smooth seas  
April 5 - Over cast and 1 foot seas

Sample Number	PA*	PA*	PA*	PA*	PA*	PA*	PA*	PA*	PA*
	1	2	3	4	5	6	7	8	10
Water Depth (Ft.)	6.4	9.5	9.5	9.0	5.8	9.3	11.0	11.4	10.4
DO (mg/L)	7.27	7.89	8.23	7.85	7.69	7.44	8.07	8.01	7.91
	6.16	2.77	7.2	6.75	7.50	7.09	6.74	6.96	7.45
pH	7.36	7.60	7.58	7.52	7.59	7.61	7.61	7.60	7.55
	7.28	7.13	7.48	7.45	7.57	7.52	7.50	7.53	7.52
Salinity (psu)	11.73	11.24	11.10	11.70	11.80	11.46	11.61	11.71	11.92
	12.29	19.01	11.23	12.98	11.96	12.30	14.28	14.58	12.99
Water Temp. (°C)	21.15	21.58	21.55	21.08	21.22	21.43	21.18	21.23	21.26
	21.41	20.78	21.45	21.48	21.20	21.43	21.55	21.41	21.26
NTU	12.78	12.28	12.14	12.74	12.86	12.51	12.66	12.78	12.97
	13.37	20.28	12.26	14.20	13.00	13.39	15.44	15.97	14.23
Air Temp. (°C)	24.6	25.2	25.0	24.7	24.7	25.5	25.4	25.5	25.7
Lat.	N30 21 07.00	N30 21 29.2	N30 21 29.2	N30 20 39.5	N30 20 39.5	N30 20 39.5	N30 19 50.4	N30 19 50.8	N30 19 50.6
Long.	W89 06 48.80	W89 04 53.3	W89 04 04.2	W89 06 31.1	W89 05 42.3	W89 04 04.2	W89 05 42.7	W89 04 53.3	W89 04 04.0
Substrata	2	1	1	1	3	1	1	1	1
Secchi Depth (ft)	1.5	2.0	1.5	2.5	1.5	1.5	1.5	1.5	1.5
Time	10:09	12:04	11:55	10:29	10:33	11:43	10:56	11:12	11:24
Comment	4/5/2012	4/5/2012	4/5/2012	4/5/2012	4/5/2012	4/5/2012	4/5/2012	4/5/2012	4/5/2012

REMARKS \* Olny Grain Size and Sediment was collected

**WATER QUALITY DATA**

Project: **Gulfport Mississippi Expansion - Benthic Habitat Assessment**

Project Number 100018536

Date(s) Collected: April 3 & 5, 2012 Tide, MLT April 3 - 5:05 @ -0.28'  
April 5 - 4:53 @ -0.79 / 18:00 @ -0.27

Wind Direction: April 3 - East Southeast Wind Speed: April 3 - 10 to 15 mph  
April 5 - West Southwest April 5 - 15 to 20 mph

Weather and Water Conditions: April 3 - Clear skys and smooth seas  
April 5 - Over cast and 1 foot seas

Sample Number	PE-11 A	PE-11 B	PE-11 C	PM-11 A	PM-11 B	PM-11 C	PM-11 D	PM-11 E	PM-11 F
Water Depth (Ft.)	31	8	13	9.8	9.0	11.2	6.2	7.8	8.2
DO (mg/L)	8.30	7.78	8.54	8.28	8.09	8.07	7.61	7.88	9.22
	0.83	2.93	6.92	3.05	2.55	1.82	9.01	7.30	6.98
pH	7.72	7.59	7.72	7.81	7.69	7.80	7.94	8.02	7.93
	7.03	7.17	7.62	7.28	7.28	7.23	7.89	7.70	7.60
Salinity (psu)	11.68	11.39	11.51	12.88	12.71	13.08	11.94	11.77	11.74
	30.82	18.32	12.55	24.30	23.15	26.75	11.95	13.31	14.23
Water Temp. (°C)	21.61	21.75	21.62	21.79	22.14	21.88	22.34	22.35	22.24
	18.81	20.72	20.32	20.00	20.16	19.66	22.33	21.95	21.77
NTU	12.78	12.44	12.55	13.91	13.74	14.14	13.00	12.82	12.79
	30.71	19.00	20.55	24.80	23.78	26.97	13.00	14.62	15.42
Air Temp. (°C)	25.6	24.7	24.8	26.8	27.3	27.8	28.8	28.7	28.3
Lat.	N30 21 19.3	N30 21 19.3	N30 21 14.4	N30 20 59.5	N30 20 49.9	N30 20 49.7	N30 20 39.9	N30 20 39.7	N30 20 39.6
Long.	W89 05 12.6	W89 05 07.8	W89 05 07.8	W89 05 22.9	W89 05 32.7	W89 05 22.9	W89 05 22.8	W89 05 13.1	W89 05 03.7
Substrata	1	1	1	1	1	1	3	3	1
Secchi Depth (ft)	2.0	2.0	2.0	1.5	2.0	1.5	1.5	2.0	1.5
Time	12:59	12:21	12:33	19:04	18:51	18:30	17:31	17:52	18:05
Comment	4/5/2012	4/5/2012	4/5/2012	4/5/2012	4/5/2012	4/5/2012	4/5/2012	4/5/2012	4/5/2012

REMARKS:

**WATER QUALITY DATA**

Project: **Gulfport Mississippi Expansion - Benthic Habitat Assessment**

Project Number 100018536

Date(s) Collected: April 3 & 5, 2012 Tide, MLT April 3 - 5:05 @ -0.28'  
April 5 - 4:53 @ -0.79 / 18:00 @ -0.27  
 Wind Direction: April 3 - East Southeast Wind Speed: April 3 - 10 to 15 mph  
April 5 - West Southwest April 5 - 15 to 20 mph  
 Weather and Water Conditions: April 3 - Clear skys and smooth seas  
April 5 - Over cast and 1 foot seas

Sample Number	PM-11 G	PM-11 H	PM-11 I	PN-11 A	PN-11 B	TB-11 A	TB-11 B	TB-11 C	TB-11 D
Water Depth (Ft.)	8.8	8.8	7.2	15.3	7.6	16.0	10.7	9.5	10.5
DO (mg/L)	8.09	8.92	7.70	9.41	2.44	7.70	7.75	8.57	8.86
	6.05	3.47	8.83	3.45	6.17	5.77	2.60	3.24	4.10
pH	7.87	7.78	7.81	7.95	7.98	7.91	7.81	7.82	7.85
	7.52	7.46	7.81	7.32	7.52	7.43	7.24	7.24	7.31
Salinity (psu)	11.69	11.79	11.79	11.63	11.71	12.03	12.21	11.90	11.86
	13.52	19.41	11.74	27.13	15.62	15.95	23.43	20.96	21.28
Water Temp. (°C)	22.14	22.09	22.16	21.61	21.76	22.12	21.75	21.96	22.10
	21.6	20.69	22.16	19.62	20.91	20.01	20.15	20.48	20.37
NTU	12.75	12.83	12.85	12.68	12.75	13.09	13.36	12.95	12.92
	14.92	20.29	12.81	26.57	17.01	16.98	23.92	21.05	5.27
Air Temp. (°C)	28.9	28.9	28.9	25.9	25.9	25.9	26.0	26.8	26.7
Lat.	N30 20 30.2	N30 20 30.1	N30 20 30.3	N30 21 34.0	N30 21 38.8	N30 20 49.5	N30 20 49.7	N30 20 39.9	N30 20 39.7
Long.	W89 05 22.8	W89 05 12.9	W89 05 03.2	W89 05 37.9	W89 05 37.6	W89 05 03.1	W89 04 53.0	W89 04 53.4	W89 04 43.2
Substrata	1	1	1	1	3	1	1	1	1
Secchi Depth (ft)	2.0	2.0	2.0	1.5	2.0	2.0	2.0	2.0	2.0
Time	16:20	16:41	16:57	13:15	13:25	13:52	14:23	14:53	15:11
Comment	4/5/2012	4/5/2012	4/5/2012	4/5/2012	4/5/2012	4/5/2012	4/5/2012	4/5/2012	4/5/2012

REMARKS TB-11-D , TB-11-E, & TB-11-F makeup DUP 1

**WATER QUALITY DATA**

Project: **Gulfport Mississippi Expansion - Benthic Habitat Assessment**

Project Number 100018536

Date(s) Collected: April 3 & 5, 2012 Tide, MLT April 3 - 5:05 @ -0.28'  
April 5 - 4:53 @ -0.79 / 18:00 @ -0.27

Wind Direction: April 3 - East Southeast Wind Speed: April 3 - 10 to 15 mph  
April 5 - West Southwest April 5 - 15 to 20 mph

Weather and Water Conditions: April 3 - Clear skys and smooth seas  
April 5 - Over cast and 1 foot seas

Sample Number	TB-11 E	TB-11- F	SA* 19						
Water Depth (Ft.)	31.4	9.2	5.4						
DO (mg/L)	8.83	8.64	6.76						
	0.83	3.76	7.28						
pH	7.81	7.85	7.85						
	7.24	7.27	7.62						
Salinity (psu)	11.79	11.47	11.14						
	28.26	19.6	11.68						
Water Temp. (°C)	22.08	22.16	24.61						
	18.79	20.66	22.92						
NTU	12.66	12.51	12.24						
	28.44	20.4	15.46						
Air Temp. (°C)	26.3	27.1	26.9						
Lat.	N30 20 29.8	N30 20 30.42	N30 22 56.11						
Long.	W89 04 33.5	W89 04 44.56	W88 58 20.91						
Substrata	1	1	3						
Secchi Depth (ft)	2	2	2						
Time	15:27	15:41	15:33						
Comment	4/5/2012	4/5/2012	4/3/2012						

REMARKS TB-11-D , TB-11-E, & TB-11-F makeup DUP 1 \* Olny Grain Size and Sediment was collected